



GTM-205M-5GT

Industrial 5G LTE Modem with USB 3.1 Super Speed Plus interface. (Asia Only, Except China)

Features

- Support 5G SA/NSA Bands
- Support 4G/3G Global Bands
- Support TCP Server, TCP Client, and UDP Client Connection from 5G/4G
- Support Standard AT Commands
- Includes a Digital Input Channel to reset the System
- Supports USB 3.1 Super Speed Plus Interface.
- DIN-Rail mountable



Introduction

The GTM-205M-5G is an industrial 5G NR modem with USB Super Speed Plus interfaces that work at frequencies of 5G NR n1/n2/n3/n5/n7/n8/n12/n20/n28/ n38/n41/n66/n71/n77/n78/n79 and LTE Global Bands and WCDMA B1/B2/B4/B5/B6/B8/B9/B19. The modems utilize the 5G, 4G or 3G network to transfer data. The features of the GTM-205M-5G allow a variety of PAC and PC applications to take advantage of SMS and 5G or 4G or 3G connectivity.

Applications



System Specifications

LED Indicators	
Status	1 x Power 1 x 5G
3G System	
Frequency Band	B1/B2/B4/B5/B6/B8/B9/B19
4G System	
Data Transmission Rate	FDD: B1/B2/B3/B4/B5/B7/B8/B12/B13/B14/B17/B18/B19/B20/B25/B26/B28/B29/B30/B32/B66/B71 TDD: B34/B38/B39/B40/B41/B42/B46(LAA)/ B48(CBRS)
5G System	
Frequency Band	FDD: n1/n2/n3/n5/n7/n8/n12/n20/n28/n66/n71 TDD: n38/ n41/n77/n78/n79
Reset Input	
Type	Isolated, 3750 Vrms
ON Voltage Level	+3.5 VDC ~ +30 VDC
OFF Voltage Level	+1 VDC max.T40
Input Impedance	3 kΩ, 0.25W

COM Ports	
Ports	1 x RS-232 (Rx/D, Tx/D, GND. Only for software reset system.)
Baud Rate	115200 bps
USB	
Specification	USB 3.1 (Super speed plus)
Driver	Windows 10_x64, Windows 11
Mechanical	
Casing	Metal
Dimensions (mm)	28 x 78.5 x 100 (W x L x H)
Installation	DIN-Rail
Environment	
Operating Temperature	-25°C to 70°C
Storage Temperature	-40°C to 80°C
Humidity	5~90% RH, non-condensing

Dimensions (Units: mm)

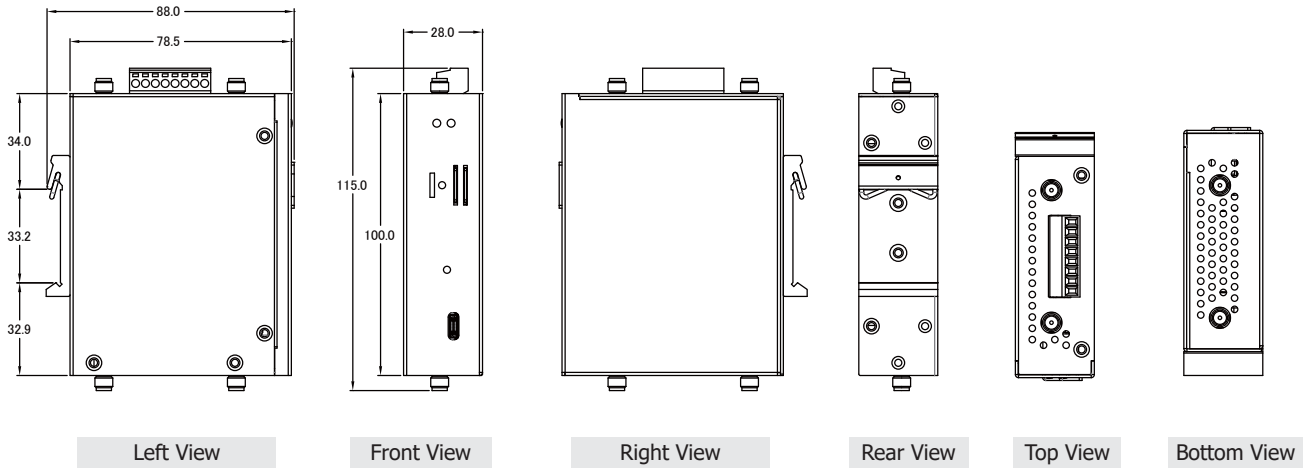

Pin Assignments

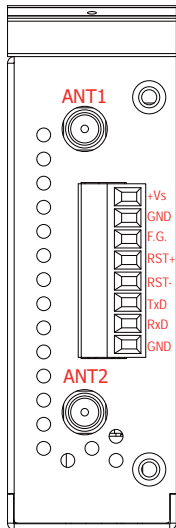

Item	Name
Power Input +10 ~ +30 VDC	+Vs
	GND
Frame Ground	F.G
Reset	RST+
	RST-
RS-232	TxD
	RxD
	GND

Ordering Information

GTM-205M-5GT CR	Industrial 5G LTE Modem with USB 3.1 Super Speed Plus interface. (RoHS) (Asia Only, Except China)
------------------------	---