

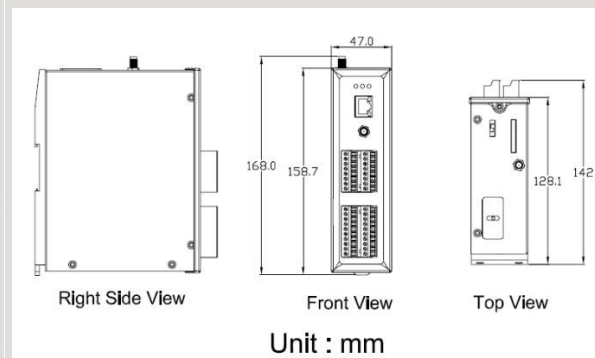

## 4G Power Saving PAC with Solar Charger



G-4514 系列



Dimensions

G-4514 是帶有 4G 模組的省電型 PAC，其內建太陽能/鉛酸電池之充電器。G-4514 極適合用於水文監控、土石流監控領域，或是不便取得電源，需要使用太陽能的應用。若配合其 GPS 功能(選購)，更可以應用於車載，河川船泊監控之領域。G-4514 帶有：太陽能電池充電器，4G 模組，Ethernet 介面、3DI、3DO、8AI、1Relay DO。

## Features

- 嵌入式 MiniOS7, anti-virus
- 支援 4G LTE
- 支援 WCDMA
- 支援 GSM
- 具太陽能 / 鉛酸電池充電器
- 10/100 Base-TX compatible 乙太網路控制器
- COM port: COM1 (5-wire RS232), COM2 (RS-485)
- I/O: 3 DI, 3 DO, 8 AI, 1 relay DO
- 支援 SD card.
- 內建 RTC, NVRAM, EEPROM
- 128\*64 dots LCM 顯示屏(選購)
- GPS : 32 channels with All-In-View tracking (選購)
- 支援 4G 的 TCP,UDP client 功能
- 在惡劣的環境中具高可靠度
- 可用 DIN-Rail 安裝

## Application

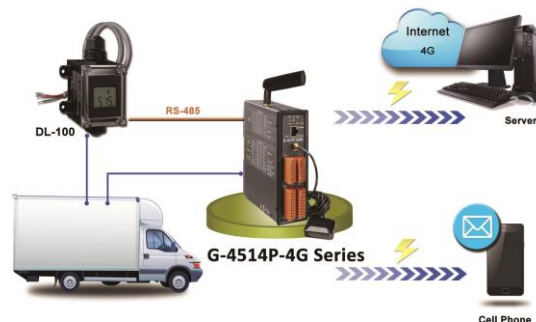



## Hardware Specifications

項目	G-4514-4GAU	G-4514D-4GAU	G-4514P-4GAU	G-4514PD-4GAU
SMS	MT, MO, CB, Text and PDU mode			
<b>GSM 介面</b>				
Frequency Band	GSM 850/900/1800/1900 MHz			
GPRS connectivity	GPRS class 10/8; GPRS station class B			
<b>3G 介面</b>				
Frequency Band	WCDMA 850/900/1900/2100 MHz			
Power Class	Class 3 (24dBm+1/-3dB) for WCDMA			
<b>4G 介面</b>				
Frequency Band	FDD LTE: B1/B2/B3/B4/B5/B7/B8/B28 TDD LTE: B40			
Power Class	Class 3 (23dBm±2dB) for LTE			

項目	G-4514-4GC	G-4514D-4GC	G-4514P-4GC	G-4514PD-4GC
SMS	MT, MO, CB, Text and PDU mode			
<b>GSM 介面</b>				
Frequency Band	GSM 900/1800 MHz			
GPRS connectivity	GPRS class 10/8; GPRS station class B			
<b>3G 介面</b>				
Frequency Band	WCDMA 900/2100 MHz TD-SCDMA 1900/2100 CDMA2000 (BC0) 800			
Power Class	Class 3 (24dBm+1/-3dB) for WCDMA			
<b>4G 介面</b>				
Frequency Band	FDD LTE: B1/B3/B8 TDD LTE: B38/B39/B40/B41			
Power Class	Class 3 (23dBm±2dB) for LTE			

## Hardware Specifications

項目	G-4514 Series	G-4514D Series	G-4514P Series	G-4514PD Series	
CPU	內建 80 MHz 微處理器				
SRAM/Flash	512/512 KB, 及時時鐘(RTC), 看門狗(Watchdog timer)				
NVRAM	31 bytes, 電池備援, 資料有效期達 10 年				
EEPROM	16 KB, 資料保存 > 40 年, 1,000,000 次清除/寫入				
<b>Comm. Interface</b>					
COM ports	COM1:5-wire RS-232; COM2: RS-485				
乙太網路(Ethernet)	10/100 Base-TX 乙太網路控制器				
<b>Digital Input</b>					
通道數量	3				
輸入型態	Source(Dry Type), Common Ground				
截止電位	+1 V max.				
道通電位	+3.5 ~ +30 V				
隔離保護電壓	Non-isolated				
<b>Digital Output</b>					
通道數量	3				
輸出型態	Open Collector (Sink/NPN)				
負載電壓	+30 VDC max.				
負載電流	100 mA max.				
隔離保護電壓	Non-isolated				
<b>Analog Input</b>					
通道數量	8				
解析度	12 - bit				
輸入範圍/型態	0 ~ 20 mA				
取樣頻率	1 KHz max. (只讀取一個通道時)				
精度	+/- 2 LSB (+/- 0.0097 mA)				
隔離保護電壓	2500Vrms 3000Dc to DC				
<b>Relay</b>					
通道數量 / 輸出型態	1 / Form C				
輸入範圍	2A@30 Vdc ; 0.25 A @250 Vac				
機械操作壽命	typ. 10 <sup>8</sup> 次操作				
<b>GPS 介面</b>					
支援通道數量	-		32		
支援協定	-		NMEA 0183		
<b>LCD Interface</b>					
一般資訊	顯示尺寸	-	80.61 mm x 14.37 mm (W x H)	-	80.61 mm x 14.37 mm (W x H)
	模組尺寸	-	93 mm x 70 mm x 1.6 mm (W x H x T)	-	93 mm x 70 mm x 1.6 mm (W x H x T)
<b>電源(太陽能輸入端)</b>					
保護	Power reverse polarity protection				
外殼接地保護	ESD, Surge, EFT, Hi-Pot				
電源需求	+10 V <sub>DC</sub> ~ +30 V <sub>DC</sub> . (Max. Voltage of Solar Panel must less +30V)				
耗電量	Sleep: < 10 mA@12V; Idle: 90 mA @ 24 V <sub>DC</sub> ; Data Link: 150 ~ 400 mA (peak) @ 24 V <sub>DC</sub>				
<b>電池</b>					
電池類型	12V 鉛酸電池				
充電電壓條件	電源端的電壓需大於+16V				
低電壓保護	低電壓斷電電壓 = 11.1V / 低電壓恢復供電電壓 = 12.6V				
<b>LED 指示燈</b>					
系統指示燈 / GSM	紅 / 黃				
GPS	-		綠		
充電指示 / 充電失敗指示	綠 / 紅				
<b>機構</b>					
外殼 / 尺寸	金屬 / 47 mm x 142 mm x 168 mm (W x L x H)				
安裝介面	DIN-Rail and Wall mount				
<b>環境</b>					
操作溫度	-20 ~ +70 °C	-15 ~ +55 °C	-20 ~ +70 °C	-15 ~ +55 °C	
保存溫度	-40 ~ +80 °C	-20 ~ +70 °C	-40 ~ +80 °C	-20 ~ +70 °C	
濕度	5~90% RH, non-condensing				