



SG-3383

3-channel DC Current Signal Splitter

Introduction

The SG-3383 DC current signal splitters accept one 4 to 20 mA current input and provide three optically isolated 4 to 20 mA current outputs that are linearly related to the 4 to 20 mA current input. This provides an economical solution when one signal must be sent to three different devices. Typical applications include isolation, output splitting, output device separation and redundancy (i.e. to prevent failure of the entire loop if one device fails), or a combination of these. The input signal is filtered, amplified, split, and then passed through an opto-coupler to the output stages. Full 3-way isolation (input, output, power), 4 kV EFT Protection for Power Line and 8 kV ESD Protection make this module useful for ground loop elimination, common mode signal rejection, and noise pickup reduction.

The SG-3383 includes an LED display that can be used to indicate whether the module is functioning correctly, and also includes VRs (Zero, Span) that can be used to calibrate the output range accuracy. The input bandwidth of the SG-3383 is typically 2.5 kHz.

System Specifications

LED Indicators/Display	
System LED Indicator	Yes, 1 as Power/Communication Indicator
Isolation	
3-way Isolation	3000 VDC
EMS Protection	
ESD (IEC 61000-4-2)	±8 kV Contact for each Terminal
EFT (IEC 61000-4-4)	±4 kV for Power Line
Power	
Reverse Polarity Protection	Yes
Input Range	+10 ~ +30 Vdc
Consumption	2.5 W
Mechanical	
Dimensions (W x L x H)	33 mm x 127 mm x 99 mm
Installation	DIN-Rail or Wall Mounting
Environment	
Operating Temperature	-25 to +75°C
Storage Temperature	-40 to +85°C
Humidity	10 to 95% RH, Non-condensing

Ordering Information

SG-3383 CR	3-channel DC Current Signal Splitter (RoHS)
-------------------	---

Features

- One 4 to 20 mA Input to Three 4 to 20 mA Outputs
- Zero and Span Adjustments for Each Output
- Full 3000 V Isolation for Input/Output/Power
- Built-In Loop Power Supplies for Sink/Source I/O
- Split, Convert, Boost, and Rescale Process Signals
- Split Process Signals for Control and Validation
- Interface a Process Signal with Multiple Panel Meters, PLCs, Recorders, Data Acquisition, DCS, and SCADA Systems
- 8 kV ESD Protection
- 4 kV EFT Protection for Power Line
- Flexible DIN-Rail Mounting



Applications

- Building Automation
- Machine Automation
- Remote Diagnosis
- Factory Automation
- Remote Maintenance
- Testing Equipment



I/O Specifications

Analog Input	
Channels	1
Range	+4 ~ +20 mA
Input Bandwidth	2.5 kHz
Input Impedance	125 Ω
Analog Output	
Channels	3
Range	+4 ~ +20 mA
Accuracy	±0.1% of FSR (typical)
Current Output Wiring	Source
Current Output Capacity	500 Ω

Internal I/O Structure

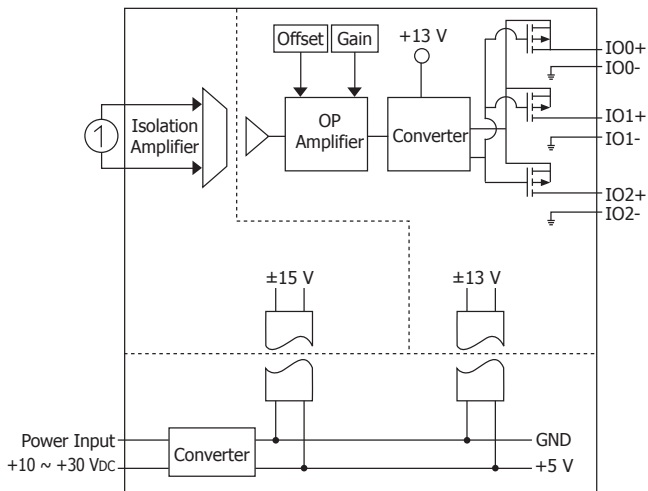

Pin Assignments

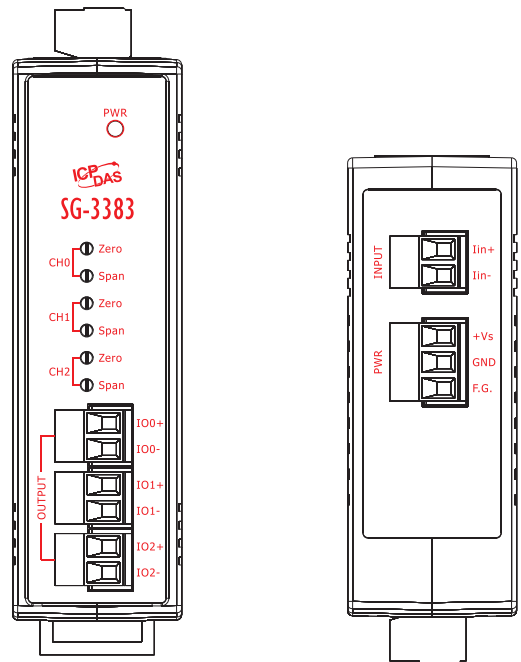

Front View

Top View

Dimensions (Units: mm)

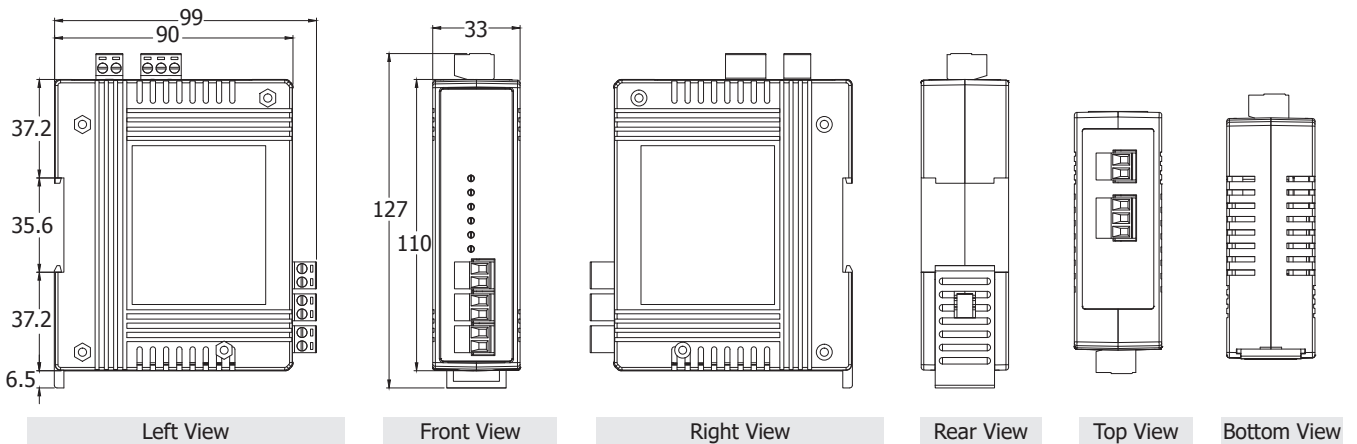

Left View

Front View

Right View

Rear View

Top View

Bottom View

Wire Connections

