



I-8041AW | I-8041W | I-8041PW

32 通道隔離型數位輸出模組

介紹

I-8041W/I-8041PW/I-8041AW 是一 32 通道隔離型開集極 (Open Collector) 數位輸出模組。數字輸出通道，每一通道皆具備光耦合隔離器和 LED 指示燈，可獨立設置。I-8041W/I-8041PW 支援 Sink 輸出，而 I-8041AW 支援具有過電壓、過載和短路保護的 Source 輸出。

I-8041W/I-8041PW/I-8041AW 還提供符合 4 kV ESD 和 3750 VDC 模組內部隔離，使其在工業環境場合能提供更好的防制雜訊干擾能力。I-8041W/I-8041PW/I-8041AW 可以與子板搭配，例如用於輕鬆接線的 DN-37-381-A，或用於繼電器輸出的 DN-8K32R。



I-8041AW, I-8041W 和 I-8041PW 可搭配選配的 DN-8K32R DB37 公轉母連接器

系統規格

型號	I-8041AW	I-8041W	I-8041PW
LED 燈			
電源 / 系統指示燈		1	
I/O 指示燈		32	
隔離			
內部隔離		3750 VDC	
EMS 防護			
ESD (IEC 61000-4-2)		每個端子的觸點具 ± 4 kV	
電源			
功耗		最大達 1.5 W	
機構			
尺寸 (W x L x H)		30 mm x 114 mm x 85 mm	
環境			
工作溫度		-25 ~ +75 °C	
儲存溫度		-40 ~ +85 °C	
濕度		10 ~ 90 % RH, 無凝露	

特色

- 32 通道隔離開集極 (Open Collector) 輸出
- 支援漏型 (Sink) 或源型 (Source) 輸出接線
- 光耦合隔離保護
- 每通道具 LED 指示燈監控通道狀態
- 接點具 4 kV 的靜電 (ESD) 防護
- 3750 VDC 模組內部隔離保護



I-8041AW, I-8041W 和 I-8041PW with DN-37-381-A 可搭配選配的 DN-37-381-A DB37 公轉母連接器

尺寸 (單位：毫米)

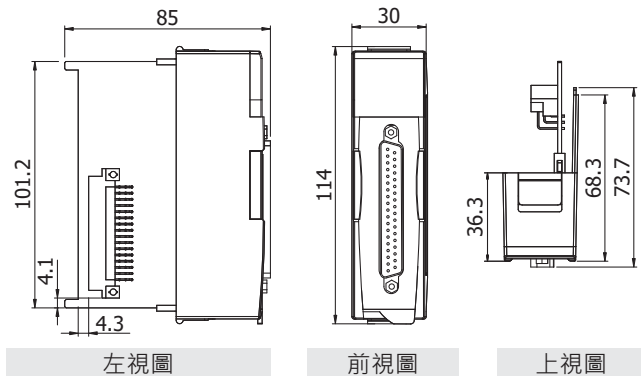

I/O 規格

型號	I-8041AW	I-8041W	I-8041PW
數位輸出			
通道數		32	
類型		隔離開集極電路 (Open Collector)	
Sink/Source (NPN/PNP)	Source	Sink	
負載電壓	+5 ~ +30 VDC	+10 ~ +50 VDC	
負載電流	100 mA/ 通道		
過電壓保護	-	60 VDC	
過載保護	-	1.1 A	
短路保護	-	是	

I/O 內部結構

I-8041AW

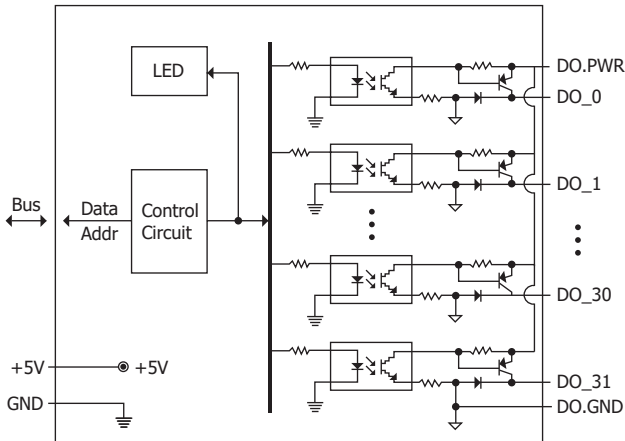

I-8041W/I-8041PW

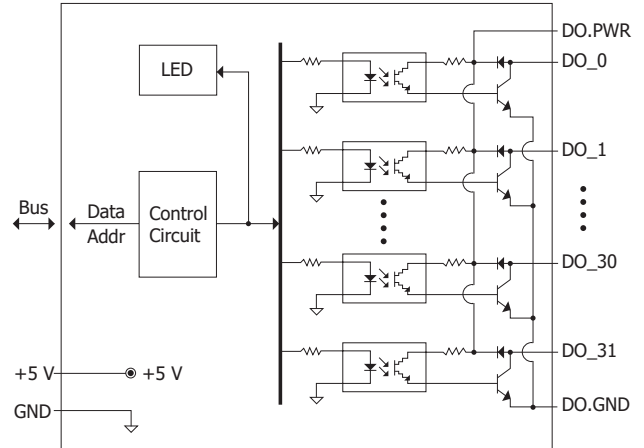

接線圖

輸出類型	I-8041AW		I-8041W/I-8041PW	
	ON State Readback as 0	OFF State Readback as 1	ON State Readback as 0	OFF State Readback as 1
Drive Relay				
Resistance Load				

接腳定義

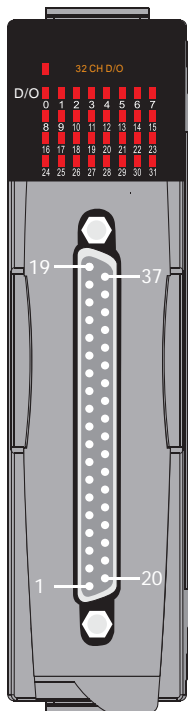

腳位定義	腳位編號	腳位定義
DO.PWR	19	37 DO.PWR
DO.GND	18	36 DO.GND
DO.GND	17	35 DO_31
DO_15	16	34 DO_30
DO_14	15	33 DO_29
DO_13	14	32 DO_28
DO_12	13	31 DO_27
DO_11	12	30 DO_26
DO_10	11	29 DO_25
DO_9	10	28 DO_24
DO_8	09	27 DO_23
DO_7	08	26 DO_22
DO_6	07	25 DO_21
DO_5	06	24 DO_20
DO_4	05	23 DO_19
DO_3	04	22 DO_18
DO_2	03	21 DO_17
DO_1	02	20 DO_16
DO_0	01	

37-pin Male D-Sub 連接器

配件

DN-37-A CR



DB37 母頭 - 螺絲端子板 (Pitch= 5.08 mm) (DIN-rail 安裝) (RoHS)
包含 CA-3710A (DB37 公頭 對 母頭, 90°, 1M)



DN-37-381-A CR



DB37 母頭 - 螺絲端子板 (Pitch= 3.81 mm) (DIN-rail 安裝) (RoHS)
包含 CA-3710A (DB37 公頭 對 母頭, 90°, 1M)



CA-3705A CR/CA-3710A/CA-3715A CR



DB37 公轉母連接線, 90°, 0.5 M/1 M/1.5 M (RoHS)

CA-3710AM/CA-3720AM/CA-3730AM/ CA-3750AM/CA-37100AM CR



DB37 公轉母, 一體成型連接線, 45°, 1 M/2 M/5 M/10 M (RoHS)

訂購資訊

I-8041AW-G CR	32 通道隔離型數位輸出 (Source, 5 ~ 30 VDC) 模組 (RoHS)
I-8041W-G CR	32 通道隔離型數位輸出 (Sink, 5 ~ 30 VDC) 模組 (RoHS)
I-8041PW-G CR	32 通道隔離型數位輸出 (Sink, 10 ~ 50 VDC) 模組 (RoHS)