

## XV310

4-ch AI, 2-ch AO, 4-ch DI and 4-ch DO  
Expansion Board

### Features

- Multifunction (4 AI, 2 AO, 4 DI, 4 DO)
- Individual Channel Configuration
- Jumper Selectable Voltage or Current Input/Output
- Open Wire Detection for Current Output
- Configurable Power-on Value Settings
- Digital Input Channels can be used as 32-bit Counters
- 120 VDC Overvoltage Protection for Analog Input
- 60 VDC Overvoltage Protection for Digital Input
- Overload Protection for Digital Output
- Short-circuit Protection for Digital Output



### Introduction

The XV310 is a multifunction expansion board that includes 4 analog input channels, 2 analog output channels, 4 digital input channels and 4 digital output channels. It provides a programmable input range on all analog input channels (+/-1 V, +/-2.5 V, +/-5 V, +/-10 V, +/-20 mA, 0 ~ 20 mA or 4 ~ 20 mA), analog output channels are 12-bit at +/-5 V, +/-10 V, 0 ~ 20 mA or 4 ~ 20 mA. Each analog input channel can be configured for an individual range and provides a high overvoltage protection of 120 VDC. Voltage and current inputs/outputs are jumper selectable.

### Specifications

Isolation	
Intra-module Isolation	2000 VDC
EMS Protection	
ESD (IEC 61000-4-2)	±4 kV Contact For Each Terminal ±8 kV Air For Random Terminal
Analog Input	
Channels	4
Type	±1 V, ±2.5 V, ±5 V, ±10 V, ±20 mA, 0 ~ 20 mA, 4 ~ 20 mA (Jumper Selectable)
Resolution	16-bit
Accuracy	Normal Mode ±0.1% Fast Mode ±0.5%
Sampling Rate	Normal Mode 10 Hz Fast Mode 200 Hz (Total)
Overvoltage Protection	120 VDC
Individual Channel Configuration	Yes
Analog Output	
Channels	2
Type	0 V ~ +5 V, ±5 V, 0 V ~ +10 V, ±10 V, 0 mA ~ +20 mA, +4 mA ~ +20 mA (Jumper Selectable)
Resolution	12-bit
Accuracy	±0.1%
Voltage Output Capability	10 V @ 20 mA
Current Load Resistance	500 Ω
Individual Channel Configuration	Yes

Digital Input/Counter		
Channels	4	
Dry Contact	Type	Source
	ON Voltage Level	Close to GND
	OFF Voltage Level	Open
Max. Counts	32-bit (0~4,294,967,285)	
Frequency	50 Hz	
Min. Pulse Width	10 ms	
Overvoltage Protection	60 VDC	
Digital Output		
Channels	4	
Type	Source	
Load Voltage	+10 to +40 VDC	
Max. Load Current	650 mA/channel	
Overvoltage Protection	47 VDC	
Overload Protection	Yes	
Short-circuit Protection	Yes	
Power-on Value	Yes, Programmable	
COM Ports		
Ports	1 x RS-232	
Baud Rate	115200 bps	
Data Format	N, 8, 1	
Protocol	Modbus/RTU	
Power		
Consumption	1.6 W Max.	
Powered from Terminal Block	5 VDC	
Mechanical		
Dimensions (mm)	59 mm x 82 mm x 13 mm (W x L x H)	
Environmental		
Operating Temperature	-25 ~ +75 °C	
Storage Temperature	-30 ~ +80 °C	
Humidity	10 ~ 90% RH, Non-condensing	

## Pin Assignments

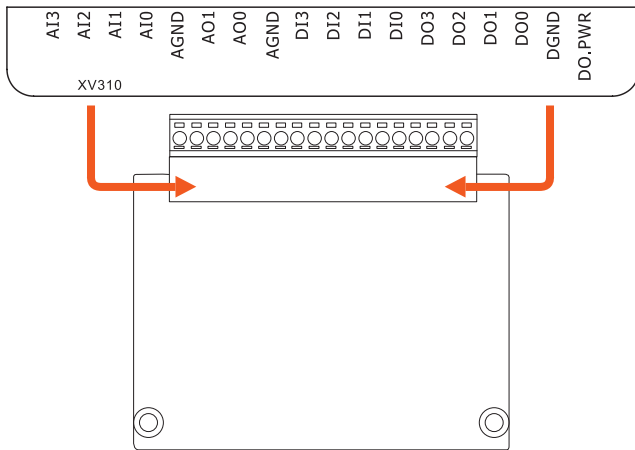

## Internal I/O Structure

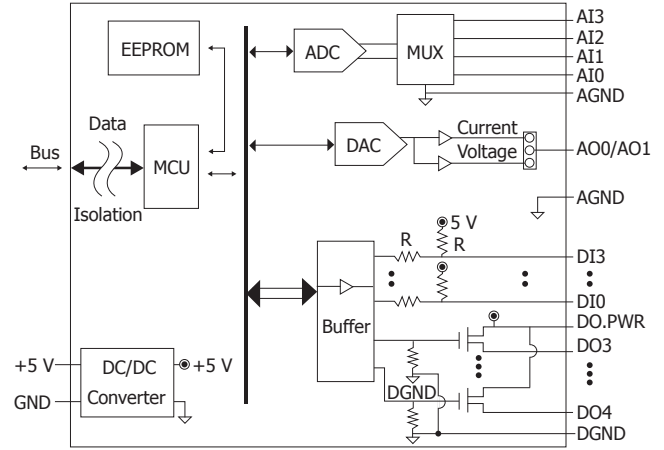

## Wire Connections

Voltage Input		
Current Input		
Voltage Output		
Current Output		
Digital Input/Counter	ON State Readback as 1	OFF State Readback as 0
Dry Contact (Source)		
Digital Output	ON State Readback as 1	OFF State Readback as 0
Open Drain (Source)		

## Ordering Information

<b>XV310 CR</b>	4-ch AI, 2-ch AO, 4-ch DI (Dry) and 4-ch DO (Source, PNP, 10 ~ 40 VDC) Expansion Board (RoHS)
-----------------	---