



MQ-7252M

MQTT I/O Module with 8-ch DI (Wet) and 8-ch DO (Source)

Features

- Built-in Web Server
- Web HMI
- Support Modbus TCP and MQTT Protocols
- 2-port Ethernet Switch (LAN Bypass) for Daisy-Chain Wiring
- Dual Watchdog
- Built-in I/O
 - DI: 8 Channels
 - DO: 8 Channels



Introduction

The MQ-7252M is an Ethernet I/O device equipped with 8-channel DI and 8-channel DO, as well as the MQTT and Modbus TCP protocols, which are supported for connecting with a variety of digital sensors in Industrial Internet of Things (IIoT) applications. A web-based user interface is provided to configure the module, monitor the network connection status and I/O status, and control digital output channels on the module via a normal web browser on a mobile device or computer. The MQ-7252M features optical isolation for 2500 VDC of transient overvoltage protection but doesn't provide channel-to-channel isolation. Each output channel can drive up to 650 mA load, together with configurable power-on value and safe value. It can safely be used in applications where hazardous voltages are present.

System Specifications

Model	MQ-7252M
Software	
Built-in Web Server	Yes
CPU Module	
Watchdog Timer	Module, Communication (Programmable)
EMS Protection	
EFT (IEC 61000-4-4)	±2 kV for Power Line
ESD (IEC 61000-4-2)	±4 kV Contact for Each Terminal and ±8 kV Air for Random Point
Surge (IEC 61000-4-5)	±2 kV for Power Line
LED Indicators	
Status	Run, Ethernet, I/O
Ethernet	
Ports	2 x RJ-45, 10/100 Base-TX, Switch Ports
LAN bypass	Yes
Protocol	MQTT 3.1 Modbus TCP
Isolation	1500 VDC
Power	
Reverse Polarity Protection	Yes
Consumption	3.4 W Max.
Powered from Terminal Block	+12 ~ +48 VDC
Mechanical	
Casing	Metal
Dimensions (mm)	97 x 120 x 42 (W x L x H)
Installation	DIN-Rail or Wall mounting
Environmental	
Operating Temperature	-25 ~ +75 °C
Storage Temperature	-30 ~ +80 °C
Humidity	10 ~ 90% RH, Non-condensing

I/O Specifications

Model	MQ-7252M
Digital Input	
Channels	8
Type	Wet Contact
Sink/Source (NPN/PNP)	Sink/Source
ON Voltage Level	+10 ~ +50 VDC
OFF Voltage Level	+4 VDC Max.
Input Impedance	10 kΩ
Overvoltage Protection	+70 VDC

Model	MQ-7252M
Digital Output	
Channels	8
Type	Isolated Open Collector
Sink/Source (NPN/PNP)	Source
Load Voltage	+10 ~ +40 VDC
Load Current	650 mA/channel at 25 °C
Overvoltage Protection	+47 VDC
Short-circuit Protection	Yes
Power on Value	Programmable
Safe Value	Programmable

Wire Connections

Input Type	Readback as 1	Readback as 0
Sink	+10 ~ +50 VDC 	OPEN or <4 VDC
	+10 ~ +50 VDC 	OPEN or <4 VDC

Output Type	ON State Readback as 1
Source	
	OFF State Readback as 0

Dimensions (Units: mm)

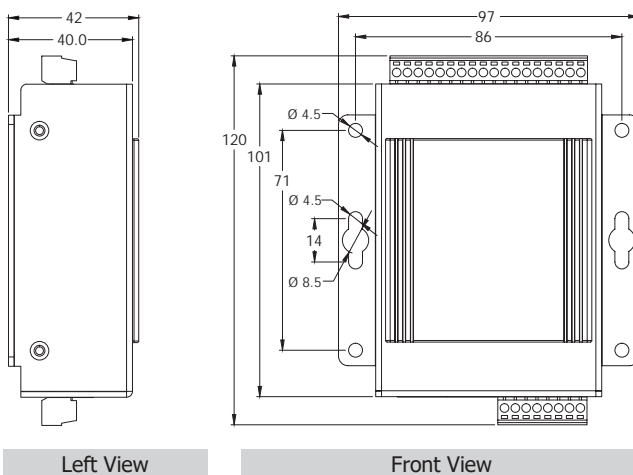

Pin Assignments

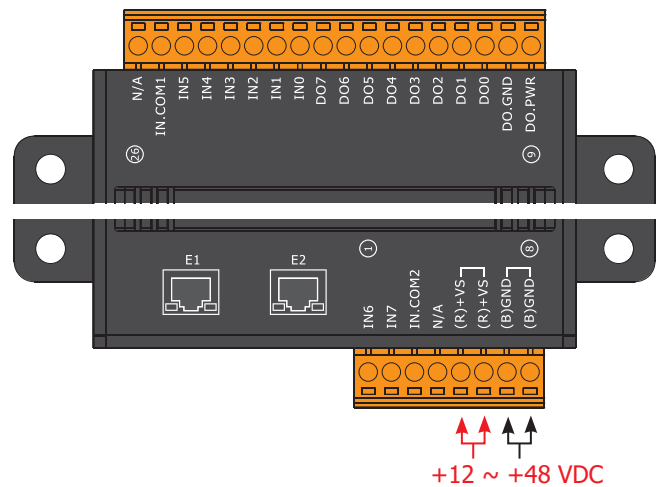

Ordering Information

MQ-7252M CR	MQTT I/O Module with 2-port Ethernet Switch with 8-ch DI (Wet) and 8-ch DO (Source) (RoHS)
--------------------	--