

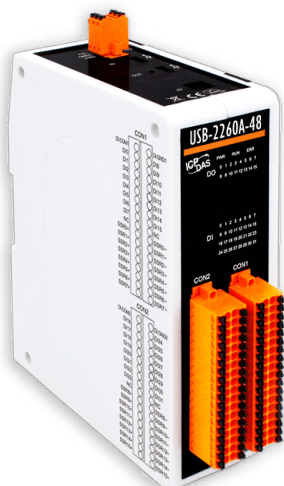

USB-2260A-24

USB I/O Module
with Isolated 16-ch
DI and 8-ch
AC-SSR Output



USB-2260A-48

USB I/O Module
with Isolated 32-ch
DI and 16-ch
AC-SSR Output

Features

- 16/32-ch digital input and 8/16-ch AC-SSR output
- SSR technology also eliminates potential for arcing, bounce, and switching noise
- Digital input selectable dry/wet contacts via wires
- All digital inputs can act as 32-bit counters
- Dual watchdog with power-on and safe values
- 2-port USB 2.0 hub for daisy-chain wiring
- Plug-and-Play without driver
- Lockable USB cable
- Easy-to-use tool for setup and I/O testing
- API library (VB/C++/C#.NET/VB.NET/LabVIEW)
- Support 32/64-bit Win7/8/10/11 and Linux



Introduction

The USB-2260A-24 and USB-2260A-48 are USB 2.0 I/O devices with 16 or 32 digital inputs and 8 or 16 AC-SSR (Solid State Relay). SSR technology provides a faster response time and greater electrical endurance. The integration of AC-SSR technology also eliminates potential for arcing, bounce, and switching noise. All digital inputs can operate as 32-bit counters and support selectable sink or source configurations via wires. Both models also have LED indicators to display the status of the digital channels.

A dual watchdog function with configurable power-on and safe values ensures reliable operation in harsh environments.

We also provide API library and demos with source code for Windows and Linux users to develop their own USB applications with various development tools (VB/C++/C#.NET/VB.NET/LabVIEW). Therefore, the USB-2260A-24/USB-2260A-48 is the perfect choice for you to implement I/O expansion via a plug-and-play USB interface.

Applications

- Building automation
- Factory automation
- Measurement and testing
- Testing equipment
- Machine automation

Daisy-Chain USB Cabling

The USB-2200 module is equipped with a USB hub that supports daisy chain topologies. This feature allows more USB-2200 modules to be integrated into a single system and also frees up PC USB ports.

Note : The USB 2.0 port provides only 500mA, external power is required when multiple modules are connected to the same USB port. Please refer to the following figure shown daisy chain application.

Daisy-Chain USB Cabling

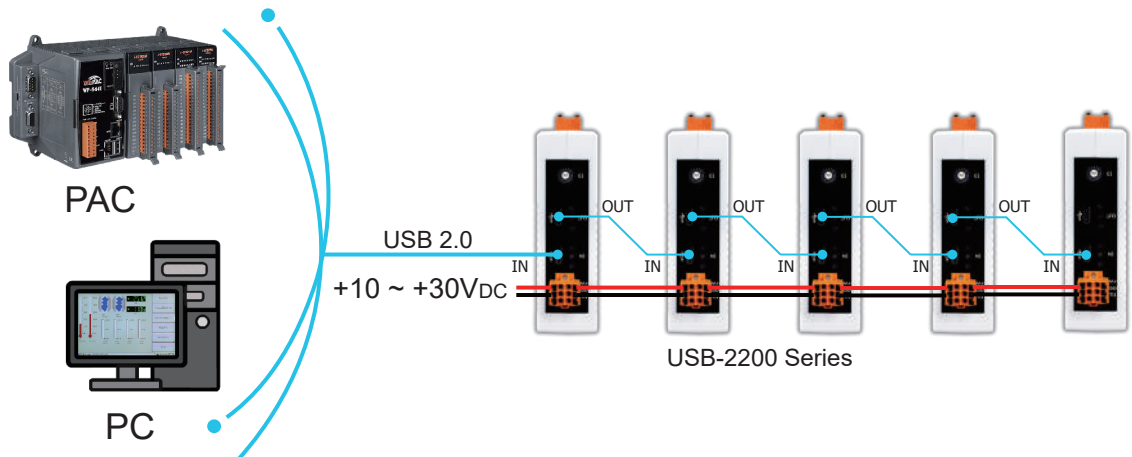

Note : Support daisy-chain, max. 5 nodes.

Redundant Power

The modules support dual power inputs (+10 to +30 VDC) for enhanced redundancy. If one source becomes inactive or is interrupted, the other immediately takes over to ensure uninterrupted operation in critical environments. The modules can operate as normal with only a single power source. (If not using the USB hub function, the module can be powered via a USB 2.0 port.)

Software

USB I/O Utility

The software supports all ICP DAS USB I/O modules, simplifies I/O control and testing, and allows for immediate data acquisition without programming.

- Automatically scans all I/O modules
- Quickly configures and tests I/O modules
- Completely and accurately logs I/O data for analysis

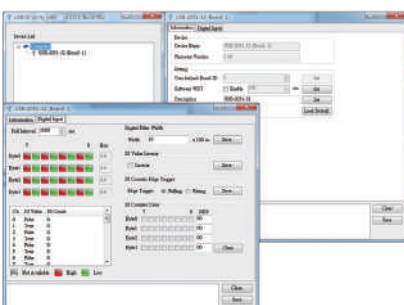

VB/C++/C#.NET/VB.NET/LabVIEW SDK

ICP DAS provides a SDK for USB I/O modules to help user to develop own project easily and quickly. The SDK can be supported in VB/C++/C#.NET/VB.NET/LabVIEW to fulfill project development.

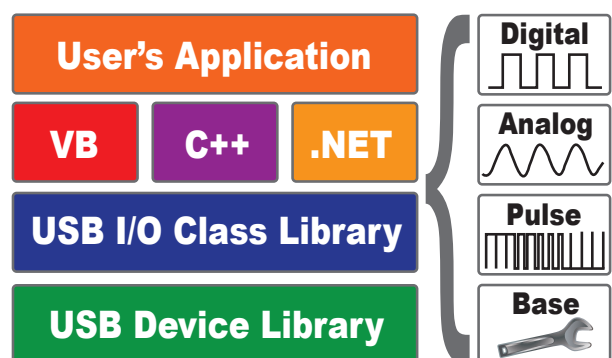

System Specifications

Model	USB-2260A-24	USB-2260A-48
USB		
Specification	USB 2.0 HighSpeed (480 Mbps)	
Connector	1 x USB IN (CA-USB-AC2-L018 CR) 1 x USB OUT (CA-USB-CC1-L003 CR) or (CA-USB-CC2-L003 CR)	
CPU Module		
Watchdog Timer	1 Hardware watchdog (1.6 second) 1 Software watchdog (Programmable)	
EMS Protection		
ESD (IEC 61000-4-2)	4 kV contact for each terminal 8 kV air for random point	
LED Indicators		
Status	3 x Power, Run and Error	
	24 x DI and AC-SSR	48 x DI and AC-SSR
Power		
Reverse Polarity Protection	Yes	
Powered from Terminal Block	+10 ~ +30 VDC	
Consumption	Typical 1.4 W Max. 1.9 W	Typical 2.1 W Max. 3.2 W
Mechanical		
Dimensions (W x L x H)mm	31 x 166 x 129	56 x 180 x 144
Environmental		
Operating Temperature	-25 ~ +75 ° C	
Storage Temperature	-40 ~ +85 ° C	
Humidity	10 ~ 95% RH, Non-condensing	

I/O Specifications

Model	USB-2260A-24	USB-2260A-48
Digital Input/Counter		
Channels	16	32
Type	Dry Contact, Source Wet Contact, Sink/Source	
Wet Contact	ON Voltage Level	+10 VDC ~ +50 VDC
	OFF Voltage Level	+4 VDC Max.
Dry Contact	ON Voltage Level	Close to GND
	OFF Voltage Level	Open
	Effective Distance	500 meters Max.
Max. Counts	32-bit	
Frequency	5k Hz	
Digital Filter Width	1 ~ 65000 * 100 μ s (1 ~ 6500 ms) Default= 0, Disable= 0	
Input Impedance	10 K Ω	
Overvoltage Protection	70 VDC	
Intra-Module Isolation	3000 VDC	
Relay Output		
Channels	8	16
Type	Solid State Relay (AC-SSR, Form A)	
Contact Rating	1 A @24 ~ 265 VAC (Operating Temperature -25 to +25° C) 0.8 A @24 ~ 265 VAC (Operating Temperature +25 to +40° C) 0.5 A @24 ~ 265 VAC (Operating Temperature +40 to +60° C) 0.35 A @24 ~ 265 VAC (Operating Temperature +60 to +75° C)	
Leakage Current	1.5 mA	
Operate Time	1/2 cycle + 1 ms	
Release Time	1/2 cycle + 1 ms	
Electrical Endurance	Long Life, No Arcing, No Bounce, No Switching Noise	
Safe Value	Yes, Programmable	
Power on Value	Yes, Programmable	
Intra-Module Isolation	3000 VDC	

Wire Connections

	Readback as 1	Readback as 0
Dry Contact		
Wet Contact (Sink)		
Wet Contact (Source)		
Output Type	ON State Readback as 1	OFF State Readback as 0
AC-SSR Output		

USB Type-C plug with Locking Screw



Pin Assignments

USB-2260A-24

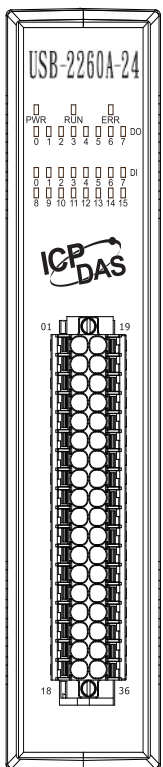

Pin Assignment	Terminal No.	Pin Assignment
DI.COM	01	19 DI.GND
DI0	02	20 DI8
DI1	03	21 DI9
DI2	04	22 DI10
DI3	05	23 DI11
DI4	06	24 DI12
DI5	07	25 DI13
DI6	08	26 DI14
DI7	09	27 DI15
NC	10	28 NC
SSR0+	11	29 SSR0-
SSR1+	12	30 SSR1-
SSR2+	13	31 SSR2-
SSR3+	14	32 SSR3-
SSR4+	15	33 SSR4-
SSR5+	16	34 SSR5-
SSR6+	17	35 SSR6-
SSR7+	18	36 SSR7-

USB-2260A-24 & USB-2260A-48

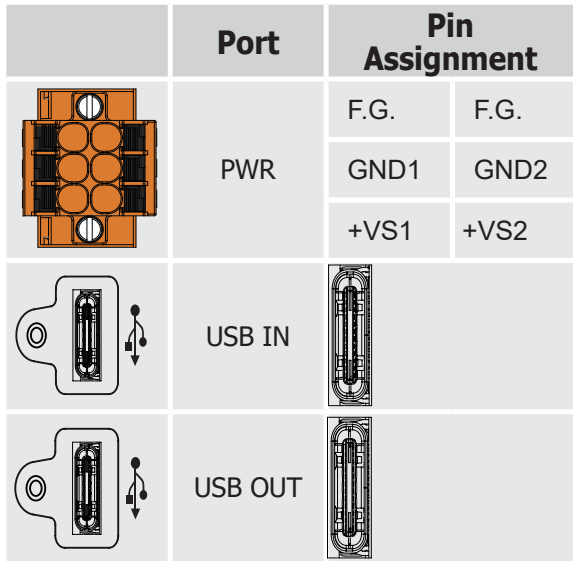

USB-2260A-48

CON2

Pin Assignment	Terminal No.	Pin Assignment
DI.COM2	01	19 DI.GND2
DI16	02	20 DI24
DI17	03	21 DI25
DI18	04	22 DI26
DI19	05	23 DI27
DI20	06	24 DI28
DI21	07	25 DI29
DI22	08	26 DI30
DI23	09	27 DI31
NC	10	28 NC
SSR8+	11	29 SSR8-
SSR9+	12	30 SSR9-
SSR10+	13	31 SSR10-
SSR11+	14	32 SSR11-
SSR12+	15	33 SSR12-
SSR13+	16	34 SSR13-
SSR14+	17	35 SSR14-
SSR15+	18	36 SSR15-

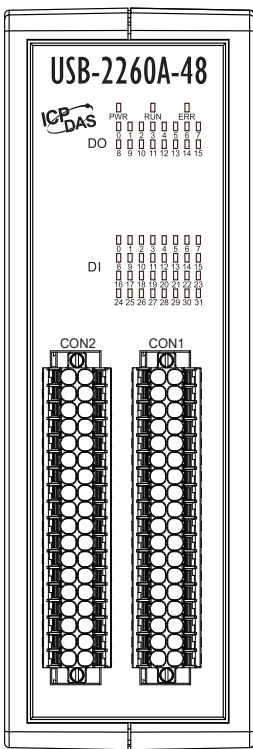

CON1

Pin Assignment	Terminal No.	Pin Assignment
DI.COM1	01	19 DI.GND1
DI0	02	20 DI8
DI1	03	21 DI9
DI2	04	22 DI10
DI3	05	23 DI11
DI4	06	24 DI12
DI5	07	25 DI13
DI6	08	26 DI14
DI7	09	27 DI15
NC	10	28 NC
SSR0+	11	29 SSR0-
SSR1+	12	30 SSR1-
SSR2+	13	31 SSR2-
SSR3+	14	32 SSR3-
SSR4+	15	33 SSR4-
SSR5+	16	34 SSR5-
SSR6+	17	35 SSR6-
SSR7+	18	36 SSR7-

■ Dimensions (Units: mm)

USB-2260A-24

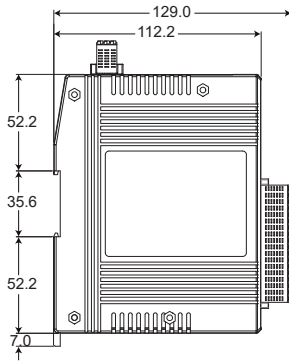

Left Side View

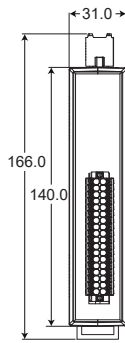

Front View

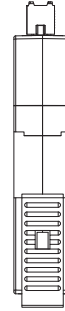

Rear View

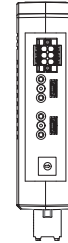

Top View

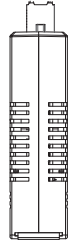

Bottom View

USB-2260A-48

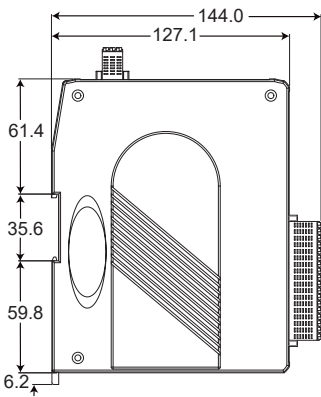

Left Side View

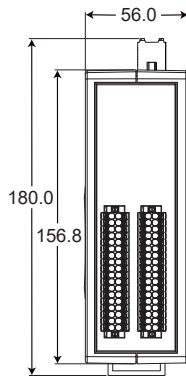

Front View

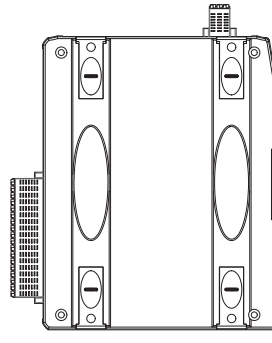

Right Side View

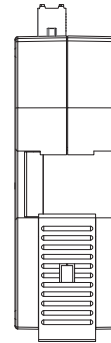

Rear View

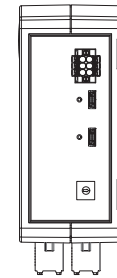

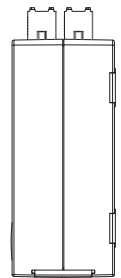

Top View





Bottom View

■ Ordering Information

USB-2260A-24 CR	USB I/O Module with Isolated 16-ch DI (Dry, Wet) and 8-ch AC-SSR Output (RoHS) Includes 1.8M USB Cable (CA-USB-AC2-L018) 
USB-2260A-48 CR	USB I/O Module with Isolated 32-ch DI (Dry, Wet) and 16-ch AC-SSR Output (RoHS) Includes 1.8M USB Cable (CA-USB-AC2-L018) 

■ Accessories

CA-USB-CC1-L003 CR Type C to Type C, with screw lock, 30 cm (RoHS)		CA-USB-CC1-L018 CR Type C to Type C, with screw lock, 1.8 M, (RoHS)	
CA-USB-CC2-L003 CR Type C to Type C, with screw lock and ferrite cores, 30cm (RoHS)		CA-USB-AC1-L018 CR USB 2.0, A to Type C with screw lock, 1.8 M, (RoHS)	