



PDS(M)-721(D) PPDS(M)-721(D)-MTCP

可程式化 (1x RS-232 和 1x RS-485)
串列設備連乙太網服務器帶 6x DI 與 7x DO

特色

- 序列設備快速連網
- "Virtual COM" 延伸 COM Port
- VxComm Utility 支援 32/64 位元 Windows 7 SP1/10/2012/2016
- 支援 Modbus TCP 轉 RTU/ASCII 閘道器功能
- 高性能且強大的可編程設備服務器
- 適用於嚴苛環境的看門狗機制設計
- 序列埠具有 +/- 4 kV 靜電放電保護電路
- 內建 RS-485 方向自動控制
- 內嵌高效能的泓格 MiniOS7 系統
- 支援 Latched D/I 和計數器功能
- 掌上型帶多個 Serial Ports



規格

Models	PDS-721 PDSM-721	PDS-721D PDSM-721D	PPDS-721-MTCP PPDSM-721-MTCP	PPDS-721D-MTCP PPDSM-721D-MTCP
CPU				
CPU	80186, 80 MHz or compatible			
SRAM	512 KB			
Flash Memory	Flash ROM: 512 KB; Erase unit is one sector (64 KB); 100,000 erase/write cycles			
EEPROM	16 KB; Data retention: 40 years; 1,000,000 erase/write cycles			
Built-in Watchdog Timer	Yes			
Communication Interface				
Non-isolated	COM1	RS-232 (Tx/D, Rx/D, RTS, CTS, GND)		
	COM2	RS-485 (D2+, D2-, GND)		
Ethernet	10/100 Base-TX, RJ-45 port (Auto-negotiating, auto MDI/MDI-X, LED indicator)			
PoE	-		IEEE 802.3af	
COM Port Formats				
Data Bit	7, 8: for COM1 and COM2			
Parity	None, Even, Odd, Mark, Space None parity is required when using 8 data bits and 2 stop bits on COM1/COM2.			
Stop Bit	1, 2: for COM1 ~ COM2			
Baud Rate	115200 bps max.			
LED Indicators				
5-digit 7 Segment	-	Yes	-	Yes
System	Red			
PoE	-		Green	
Power				
Protection	Power Reverse Polarity Protection			
Required Supply Voltage	+10 Vdc ~ +30 Vdc		PoE or +12 Vdc ~ +48 Vdc	
Power Consumption	2.0 W	2.7 W	2.2 W	2.9 W
Mechanical				
Flammability	Fire Retardant Materials (UL94-V0 Level)			
Dimensions (W x L x H)	(P)PDS: 72 mm x 35 mm x 123 mm · (P)PDSM: 102 mm x 29 mm x 125 mm			
Installation	(P)PDS-700 Series: DIN-Rail or Wall mounting			
	(P)PDSM-700 Series: Wall mounting			
Casing	Metal for PDSM/PPDSM · Plastic for other			
Environment				
Operating Temperature	-25 °C ~ +75 °C			
Storage Temperature	-40 °C ~ +80 °C			
Humidity	5 ~ 90% RH, non-condensing			

介紹

PDS 系列可編程設備服務器可將 RS-232/485/422 設備透過網路連結在一起。透過 VxComm Utility 可使 PDS 內嵌的 COM Port 模擬成為電腦主機的標準 COM Port。憑藉著獨立操作系統、通信協定、小尺寸及高適應性，設備服務器可以應付任何現實中的網路應用需求。

PDS 系列可編程設備服務器帶有強大且可靠的 Xserver 編程架構，讓使用者可快速的設計出屬於自己的網路應用程式。內嵌的高效能 MiniOS7 啟動 PDS-700 只需 1 秒並且可以快速的給予回應。並擁有 Modbus/TCP 轉 Modbus/RTU 或 Modbus/ASCII 的閘道器功能，可支援多數使用 Modbus/TCP 協定的 SCADA/HMI 系統。

PPDS-700-MTCP 系列擁有符合 IEEE 802.3af (classification, Class 1) 規範的 Ethernet 供電 (PoE) 功能，可使用標準 Category 5 網路線由 PoE 交換機接收電源 (例：NS-205PSE)。另外，還有金屬殼設計增強保護功能的模組為 PDSM-700 系列模組，此模組是 PDS-700 裝配金屬外殼 (符合 RoHS 規範)，而 PPDSM-700-MTCP 是 PPDS-700-MTCP 裝配金屬外殼 (符合 RoHS 規範)。

PDS(M)-721(D) 與 PPDS(M)-721(D)-MTCP 搭載了 1 個 RS-232、1 個 RS-485 和 DI/DO。至於模組上可拆卸的通訊埠連接頭是專為工業領域所設定的，能更方便於接線使用。

接線

Input Type	DI Value as 0	DI Value as 1
Relay Contact	Relay ON 	Relay Off
	Voltage < 1V 	Voltage > 3.5V
Open Collector	Open Collector On 	Open Collector Off
	DO Command as 1 Relay ON 	DO Command as 0 Relay Off
Resistance Load		

I/O 規格

Models	
Digital Output	
Output Channel	7
Output Type	Open Collector (Sink/NPN)
Load Voltage	30 V _{dc} , max.
Load Current	100 mA, max.
Isolated Voltage	Non-isolated
Digital Input	
Input Channel	6
Input Type	Source (Wet Contact), Common Ground
Off Voltage Level	+1 V max.
On Voltage Level	+3.5 ~ +30 V
Isolated Voltage	Non-isolated
Counters	Channels: 6
	Max. Count: 16-bit (65535)
	Max. Input Frequency: 100 Hz
	Min. Pulse Width: 5 ms

腳位定義

Terminal No.	Pin Assignment
E1	Link/Act
	10/100M
COM1	01 CTS1
	02 RTS1
	03 Rx/D1
COM2	04 Tx/D1
	05 INIT*
	06 D2+
	07 D2-
	08 (R)+Vs
	09 (B)GND

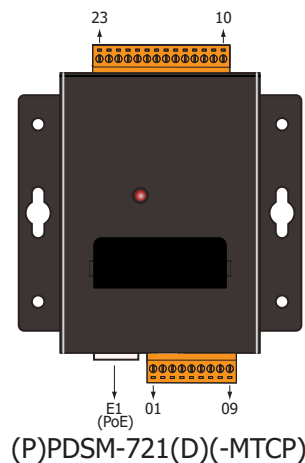
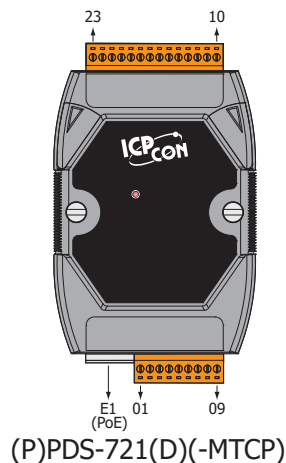

Terminal No.	Pin Assignment
DI	23 DI0
	22 DI1
	21 DI2
	20 DI3
	19 DI4
	18 DI5
DO	17 DO.PWR
	16 DO0
	15 DO1
	14 DO2
	13 DO3
	12 DO4
	11 DO5
10 DO6	

機構圖 (單位: mm)

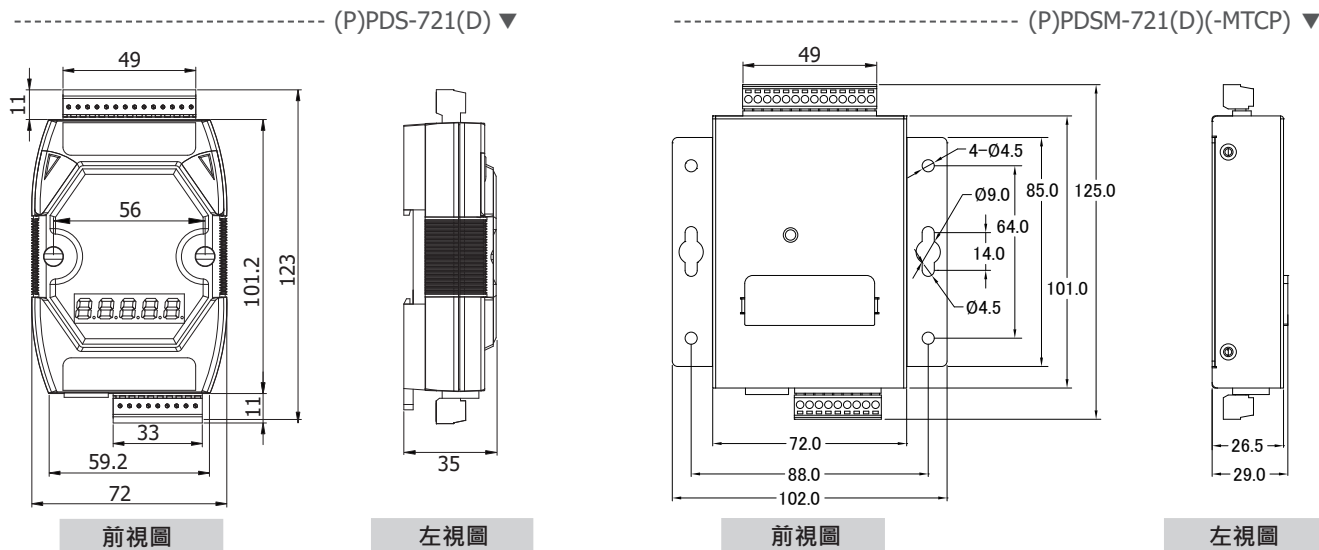

訂購資訊

PDS-721 CR	可程式化 (1x RS-232, 1x RS-485) 串列設備連乙太網服務器, 6x DI, 7x DO (RoHS) 包含 CA-0910 線材
PDS-721D CR	可程式化 (1x RS-232, 1x RS-485) 串列設備連乙太網服務器, 6x DI, 7x DO, LED 顯示 (RoHS) 包含 CA-0910 線材
PPDS-721-MTCP CR	可程式化 (1x RS-232, 1x RS-485) 串列設備連乙太網服務器, 6x DI, 7x DO, PoE, Modbus 閘道器 (RoHS) 包含 CA-0910 線材
PPDS-721D-MTCP CR	可程式化 (1x RS-232, 1x RS-485) 串列設備連乙太網服務器, 6x DI, 7x DO, PoE, Modbus 閘道器, LED 顯示 (RoHS) 包含 CA-0910 線材
PDSM-721 CR	可程式化 (1x RS-232, 1x RS-485) 串列設備連乙太網服務器, 6x DI, 7x DO (金屬殼) (RoHS) 包含 CA-0910 線材
PDSM-721D CR	可程式化 (1x RS-232, 1x RS-485) 串列設備連乙太網服務器, 6x DI, 7x DO, LED 顯示 (金屬殼) (RoHS) 包含 CA-0910 線材
PPDSM-721-MTCP CR	可程式化 (1x RS-232, 1x RS-485) 串列設備連乙太網服務器, 6x DI, 7x DO, PoE, Modbus 閘道器 (金屬殼) (RoHS) 包含 CA-0910 線材
PPDSM-721D-MTCP CR	可程式化 (1x RS-232, 1x RS-485) 串列設備連乙太網服務器, 6x DI, 7x DO, PoE, Modbus 閘道器, LED 顯示 (金屬殼) (RoHS) 包含 CA-0910 線材

配件

CA-0903 CR	DB9 母轉 5 線連接線 [RS-232], 30cm (RoHS)
NS-205 CR	非管理型 5-port 工業乙太網路交換機 (RoHS)
NS-205PSE CR	非管理型 5-port 10/100 Mbps PoE (PSE) 乙太網路交換機 (RoHS)