

EtherCAT



ECAT-2011H/ECAT-2012H

EtherCAT Slave I/O Module with 8-/16-channel AI

Features

- On the fly processing: EtherCAT
- Powerful MCU handles efficient network traffic
- 2 x RJ-45 bus interface
- Distance between stations up to 100 m (100 BASE-TX)
- Support daisy chain connection
- EtherCAT conformance test tool verified
- Removable terminal block connector
- LED indicators
- 16 Single-ended/8 Differential Analog Inputs
- RoHS compliant
- ESD Protection 4 KV Contact for each channel



Introduction

The ECAT-2000 is equipped with the EtherCAT protocol and installed by daisy chain connection which permits the flexibility in devices installation and reduces infrastructure and operation costs. All the modules can be deployed in the network topologies such as star, line or ring. The ECAT-2011H/2012H is built in isolated 8 Differential or 16-channel Single-ended Analog Inputs by software selectable. The voltage is digitised to a resolution of 12-bit(ECAT-2011H) and 16-bit(ECAT-2012H) The The ECAT-2011H/2012H has passed and verified by the conformance test tool, therefore eligible EtherCAT Master or configurator can manipulate it simply and implement your various applications easily. * EtherCAT® is registered trademark and patented technology, licensed by Beckhoff Automation GmbH, Germany

* EtherCAT® is registered trademark and patented technology, licensed by Beckhoff Automation GmbH, Germany.

Hardware Specifications

Model	ECAT-2011H	ECAT-2012H
Analog Input		
Channels	8/16	
Wire Connection	8 Differential or 16 Single-ended (Software Selectable)	
Type	Voltage, Current	
Range	0~10V, ±10 V, ±5 V, ±2.5 V, 0~ 20 mA, ±20 mA or 4~20 mA (Software selectable)	
Resolution	12-bit	16-bit
Sampling Rate	1k Hz per channel	1k Hz per channel (Max. of 6 channel enable)
Accuracy	0.2% of FSR	0.05% of FSR
Individual Channel Configuration	Yes	
Over Voltage Protection	±35 VDC	
Open Wire Detection for +4 ~ 20mA	Yes	
Communication Interface		
Connector	2 x RJ-45	
Protocol	EtherCAT	
Distance between Stations	Max. 100 m (100 BASE-TX)	
Data Transfer Medium	Ethernet/EtherCAT Cable (Min. CAT 5), Shielded	
EMS Protection		
ESD (IEC 61000-4-2)	±4 kV Contact for Each Terminal	
EFT (IEC 61000-4-4)	Signal: 1 kV Class A; Power: 1 kV Class A	
Surge (IEC 61000-4-5)	1 kV Class A	
Power		
Input Voltage Range	+10 ~ +30 VDC	
Power Consumption	4 W Max.	
Mechanical		
Dimensions (W x L x H)	33 mm x 127 mm x 108 mm	
Installation	DIN-Rail Mounting	
Case Material	UL 94V-0 Housing	
Environment		
Operating Temperature	-25 ~ +75°C	
Storage Temperature	-30 ~ +80°C	
Relative Humidity	10 ~ 90% RH, Non-condensing	

Pin Assignments

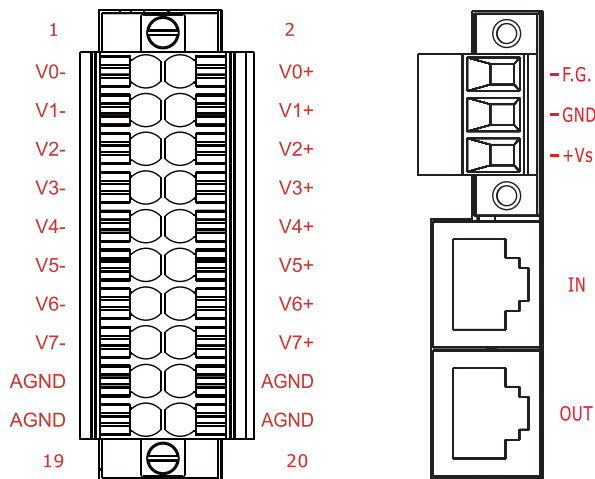

Wire Connections

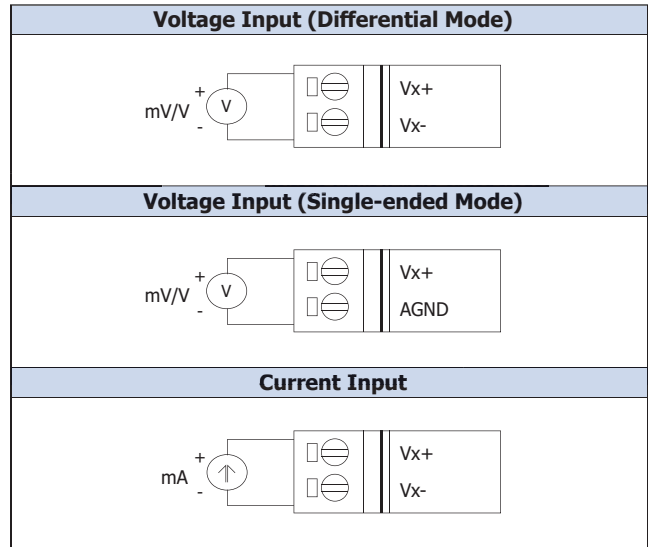

Applications

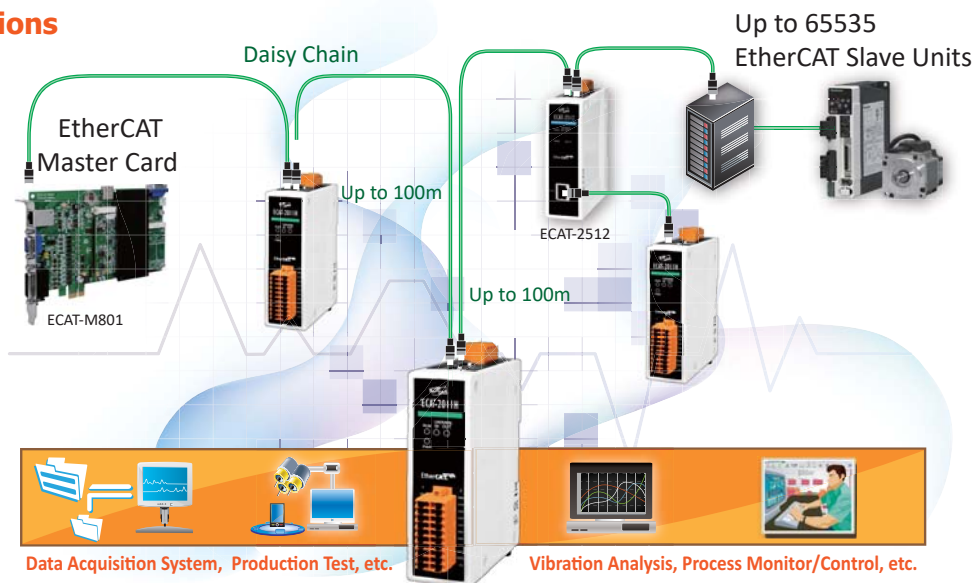

ECAT-2011H/ECAT-2012H

Dimensions (Units: mm)

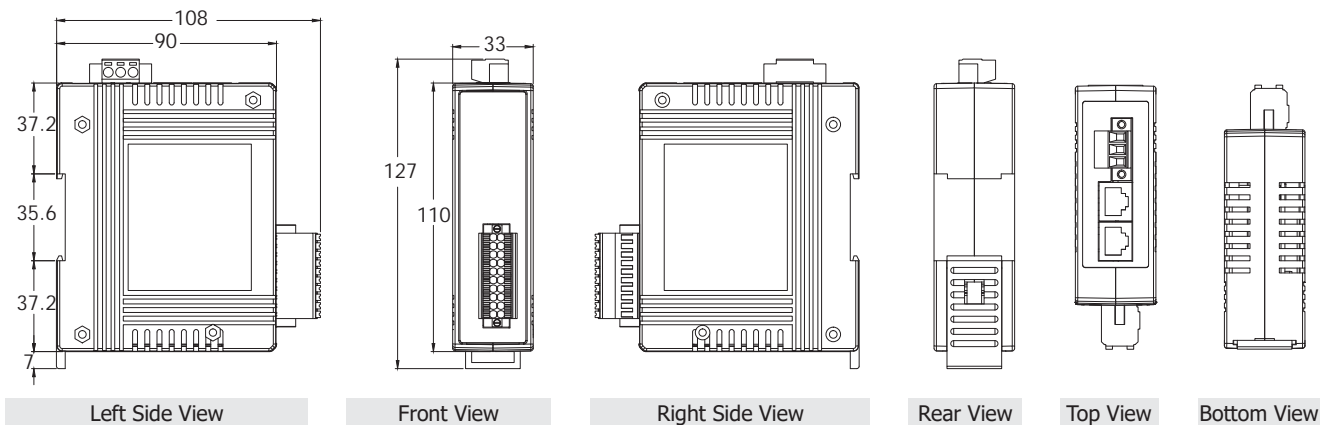

Ordering Information

ECAT-2011H CR	EtherCAT Slave I/O Module with 8 Differential or 16 Single-ended Analog Input Channels (RoHS)
ECAT-2012H CR	EtherCAT Slave I/O Module with 8 Differential or 16 Single-ended Analog Input Channels (RoHS)