



iXN-0TH



iXN-0VC



iXN-1CX

iWSN environmental sensor expansion module

Features

iXN-0TH

- Support temperature and humidity measurement
- 20 ~ +60°C and 10 ~ 95% RH

iXN-0VC

- Support CO₂e/TVOC measurement
- CO₂e: 400 ppm to 60000 ppm
- TVOC: 0 ppb to 60000 ppb

iXN-1CX

- Support CO measurement
- CO: 0 ppm to 1000 ppm



Introduction

iWSN wireless environmental sensing series including wireless signal sensing and expansion module. By means of sub-1G RF communication interface, iWSN wireless environmental sensing module can approach to the real wireless deployment. It is suitable for measuring various signals and provides users more choices for various applications, such as iXN-0TH supports temperature and humidity measurement, iXN-0VC supports CO₂e and TVOC measurement and iXN-1CX supports CO measurement. iWSN wireless environmental sensing module provide two modes of power supply: CT induced current or DC power supply. Diverse power supply delivers reliable electricity and reduces the cost of wiring. Considering the maintenance and installation, the iWSN wireless environmental sensing module uses the DIP switch for configuration. Through the flexibility of the expansion interface, the iWSN wireless environmental sensing module can be widely used in the application of saving power, big data analysis, and predict maintenance.

System Specifications

Model	iXN-0TH	iXN-0VC	iXN-1CX
Temperature Measurement			
Measuring Range	-20 ~ +60°C	-	-
Resolution	0.1°C	-	-
Accuracy	Typical: ±0.3°C	-	-
Humidity Measurement			
Measuring Range	10 ~ 95% RH	-	-
Resolution	0.1% RH	-	-
Accuracy	Typical: ±3% RH @ 20 ~ 80% RH	-	-
TVOC Measurement			
Measuring Range	-	TVOC : 400 ppm to 60000 ppm CO ₂ e : 400 ppm to 60000 ppm	CO: 0 ppm to 1000 ppm
Resolution	-	TVOC : 1 ppb (0 ppb~ 2008 ppb) 6 ppb (2008 ppb~ 11110 ppb) 32 ppb (11110 ppb~ 60000 ppb) CO ₂ e : 1 ppm (400 ppm~ 1479 ppm) 3 ppm (1479 ppm~ 5144 ppm) 9 ppm (5144 ppm~ 17597 ppm) 31 ppm (17597 ppm~ 60000 ppm)	CO: 1 ppm
Power			
Consumption	0.005 W	0.16 W	0.017 W
Input Type	iWSN environmental sensing module provides power through the audio line.		
Mechanical			
Dimensions (mm)	25 x 30 x 20.2 (W x L x H)	25 x 30 x 20.2 (W x L x H)	91 x 131 x 55 (W x L x H)
Installation	Wall-mount or magnet adsorption		
Cable Length	27 cm	27 cm	22 cm
Environment			
Operating Temperature	-20 °C ~ +60 °C	0 °C ~ +45 °C	
Storage Temperature	-30 ~ +80°C		
Ambient Relative Humidity	10 ~ 95% RH, Non-condensing		

Applications

Environmental temperature and humidity monitoring system.



Factory environmental monitoring system.

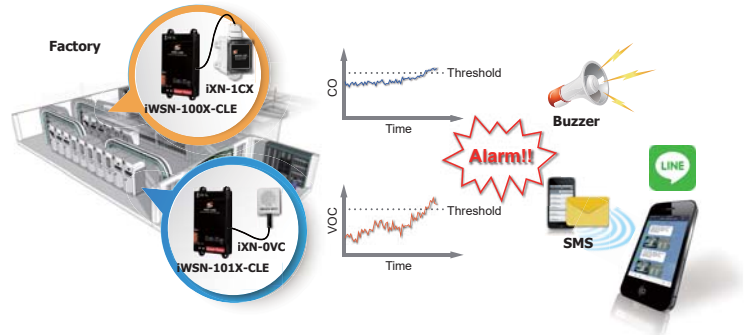

Dimensions (Units: mm)

iXN-0TH/ iXN-0VC:

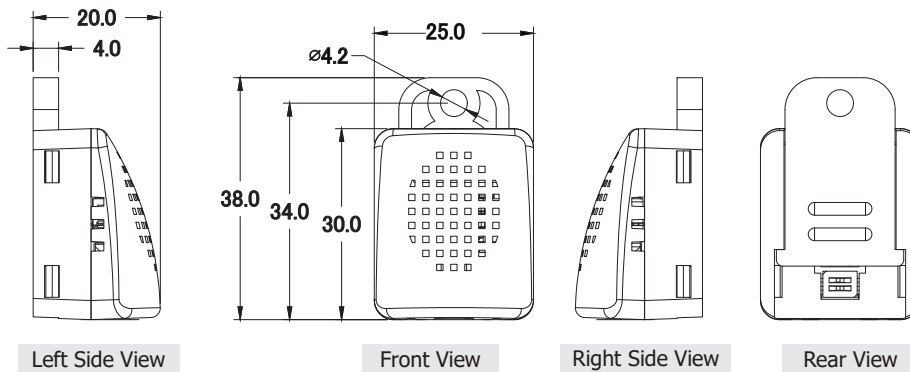

iXN-1CX:

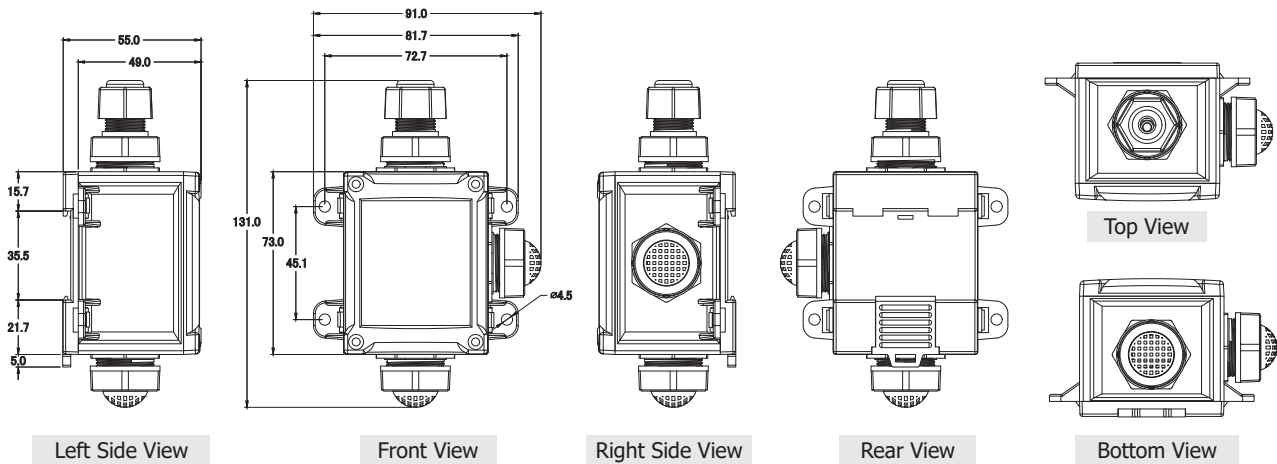

Ordering Information

iXN-0TH CR	iWSN temperature and humidity sensing module, 27 cm cable (RoHS)
iXN-0VC CR	iWSN CO ₂ e/TVOC sensing module, 27 cm cable (RoHS)
iXN-1CX CR	iWSN CO sensing module, 22 cm cable (RoHS)

Accessories

iWSN-100X-CLE CR	iWSN Environmental Sensing Module with 1-ch CT Input and 1 Expansion Interface (RoHS) (Asia Only)
iWSN-101X-CLE CR	iWSN Environmental Sensing Module with 1-ch CT Input, 1-ch Thermistor Input and 1 Expansion Interface (Asia Only)
iWSN-200U CR	iWSN data concentrator with RS-232/RS-485 serial port (RoHS)
iWSN-200E CR	iWSN data concentrator with Ethernet port (RoHS)