



iSOS-309-IP65/S2

iSOS waterproof light charging emergency call button module (Asia Only)

Features

- Provide emergency message for help report function
- Powered by built-in rechargeable Lithium Ion battery
- Supports Dye-sensitized cell charging
- Support 433MHz Radio Frequency
- Selectable 16 Radio Frequency Channels
- Active online report
- Provide wall-mounting Installation
- IP65 rated waterproof



Introduction

The iSOS-309-IP65 is a waterproof light charging wireless emergency call button product with a built-in rechargeable 16340 lithium-ion battery. With SP-S2-DS dye-sensitized charging module, it can be charged under indoor light conditions and can be used continuously without replacing the battery. Through the Sub-1G RF communication interface, it can approach real wireless deployment. It provides emergency help return function and improves personal safety protection. This system is very suitable for public area construction. For example, public toilets, hospitals, nursing homes, open campuses, large parking lots, etc. iSOS-309-IP65 delivers reliable electricity and reduces the cost of wiring. Realize emergency information transmission, meet low energy consumption, wireless communication, and emergency monitoring, etc., greatly reduce the time and human resources required for system construction and maintenance.

Specifications

RF	
Channels	0 ~ 15 (Selectable by DIP Switch)
Group ID	0 ~ 3 (Selectable by DIP Switch)
Radio Frequency	433.1000 ~ 434.6000 MHz
Transmission Power	9±1dBm (PA Off) / 18±1dBm (PA On)
Transmission Cycle	1 / 10 / 30 / 60 Secs. 3 / 5 / 10 / 30 Mins. (Selectable by DIP Switch) 1 Sec.(Emergency Triggered Only)
Transmission Distance (LoS)	50
Node ID	1 ~ 31 configured by DIP switch
Antenna	
Type	Built-in Omni-directional antenna
Power	
Consumption	0.577mAh@1 Day
Battery	16340 lithium-ion battery(3.2 VDC, 400mAh) charged by SP-S2-DS module
Mechanical	
Dimensions (mm)	90 x 167 x 103(W x L x H)
Installation	Wall-mount
Ingress Protection Rating	IP65
Environment	
Operating Temperature	-25°C ~ +60°C
Storage Temperature	-30 ~ +80°C (No battery included) -20 ~ +45°C (Battery included)
Humidity	10 ~ 90% RH(Non-condensing)

Applications

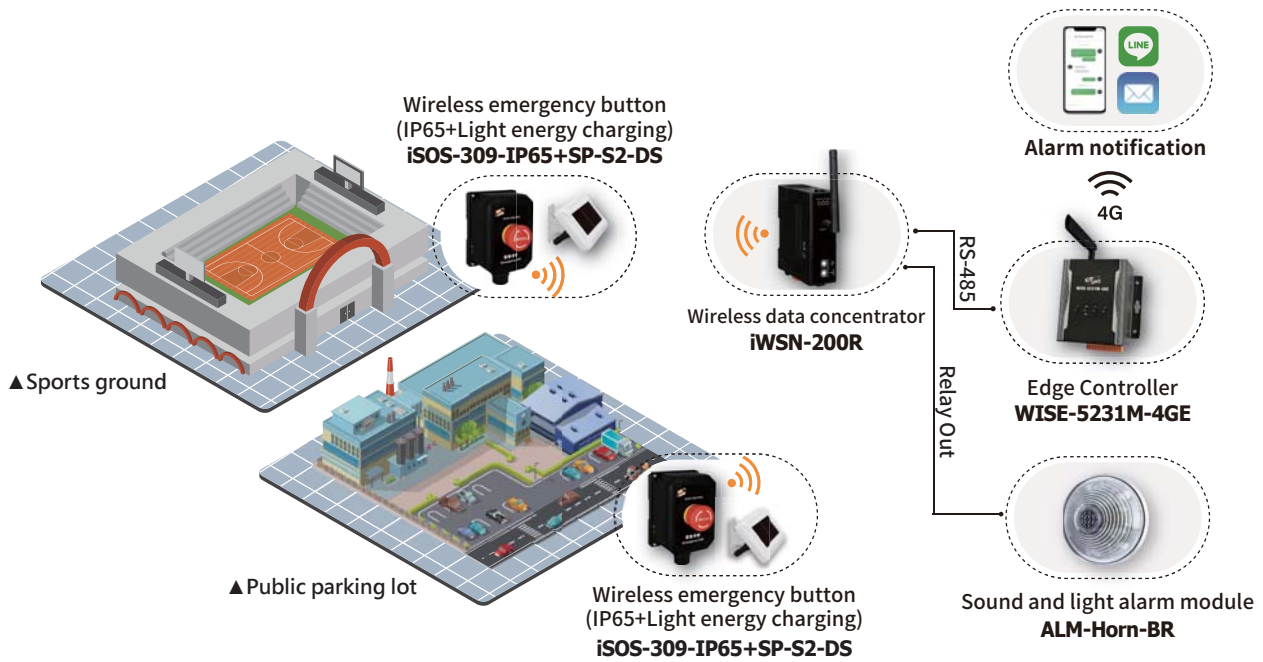

Dimensions (Units: mm)

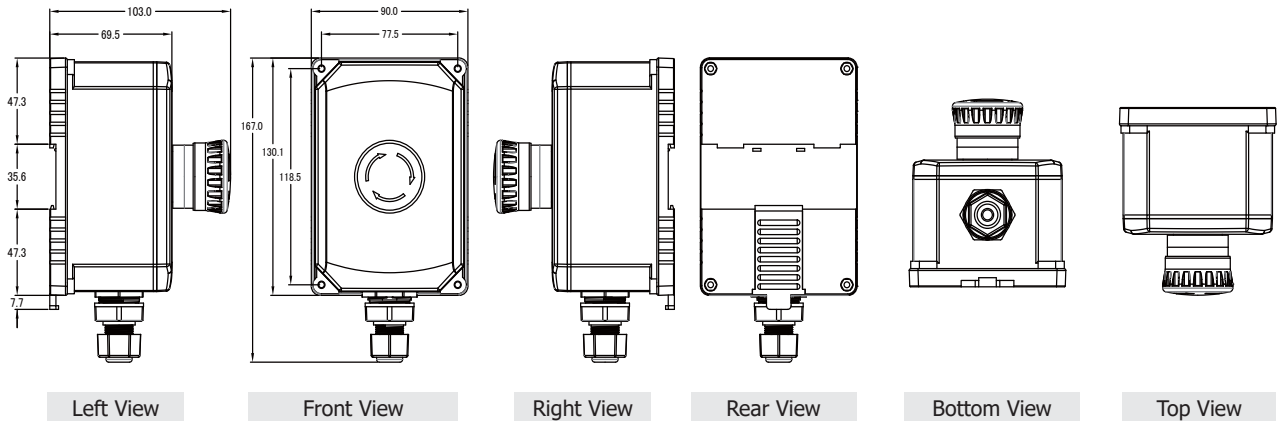

Ordering Information

iSOS-309-IP65/S2 CR

iSOS waterproof light charging emergency call button module (RoHS) (Asia Only), Includes SP-S2-DS charging module

Accessories

SP-S2-DS CR



Dye-sensitized cell charging module (RoHS)