



# Contents



<b>1</b>	<b>Voice Alert Module: ALM-06-WF</b>	<b>P 3</b>
<b>2</b>	<b>WLAN Products</b>	<b>P 4</b>
<b>3</b>	<b>Radio Modems</b>	<b>P 15</b>
<b>4</b>	<b>3G/4G Products</b>	<b>P 17</b>
	• SMS Remote Module- - - - -	P 17
	• 3G/4G Modem- - - - -	P 19
	• Mini PAC with 3G/4G Communication - - - - -	P 20
	• M2M RTU Module- - - - -	P 21
<b>5</b>	<b>NB-IoT Solution</b>	<b>P 24</b>
<b>6</b>	<b>GPS Products</b>	<b>P 32</b>
<b>7</b>	<b>Bluetooth LE Converters</b>	<b>P 32</b>
<b>8</b>	<b>ZigBee Products</b>	<b>P 33</b>
<b>9</b>	<b>Infrared Wireless Modules</b>	<b>P 36</b>
	• Universal IR Learning Remote Module- - - - -	P 37
	• IR Controlled Power Relay Module - - - - -	P 38
<b>10</b>	<b>Wireless Modbus Data Concentrators</b>	<b>P 39</b>
	• 433 MHz Modbus Data Concentrator- - - - -	P 39
	• Wi-Fi Modbus Data Concentrator / ZigBee Modbus Data Concentrator - - - - -	P 40
<b>11</b>	<b>WLS (Wireless Locating System)</b>	<b>P 41</b>
<b>12</b>	<b>iWSN Solution</b>	<b>P 48</b>
	• Comparison between Traditional and iWSN methods - - - - -	P 48
	• AC cable current required for supply and demand balancing - - - - -	P 48
	• Wireless Data Concentrator - - - - -	P 53
	• Wireless Signal Sensing Module- - - - -	P 54
	• I/O Expansion module- - - - -	P 55
	• Wireless Signal Sensing Module & Emergency Button- - - - -	P 56
	• Sensor Expansion Module - - - - -	P 57
<b>13</b>	<b>No-touch Infrared Sensor Switch (ACS-20 Series)</b>	<b>P 58</b>

# 1. Voice Alert Module: ALM-06-WF



**ALM-06-WF**

## Features:

- Compatible with IEEE 802.11 b/g/n, 2.4 GHz
- Support WEP/WPA/WPA2 wireless encryption
- Support Wi-Fi AP and Station modes
- Support Modbus TCP slave protocol
- 3W speaker, external Line out
- 99 dB/1kHz at 1m
- microSD card to store max. 64 MP3 voice files
- 6x DI, 1x Relay
- Voice Alert triggered by DI or Modbus TCP command

## Introduction:

**ALM-06-WF** is equipped with a 4 GB microSD card to store MP3 files. The ALM-06-WF can play the MP3 files when the DI status matches the pre-defined conditions or gets Modbus TCP commands via the Wi-Fi. The built-in speaker power is only 3W. It is about 99 dB, 1 meter away the module. When requires for louder sound, the module also features audio line out to external speaker.

The ALM-06-WF provides 8 modes to define the DI conditions to play MP3 files. The conditions can be simply mapped to each DI channel to have 6 conditions or mapped to 5 DI channels combination status to have 32 conditions. And every condition not only plays the MP3 files but also can be configured to turn on the built-in relay to trigger a warning lamp. That means with WLM-06-WF can have both voice and light warning.



## Applications:

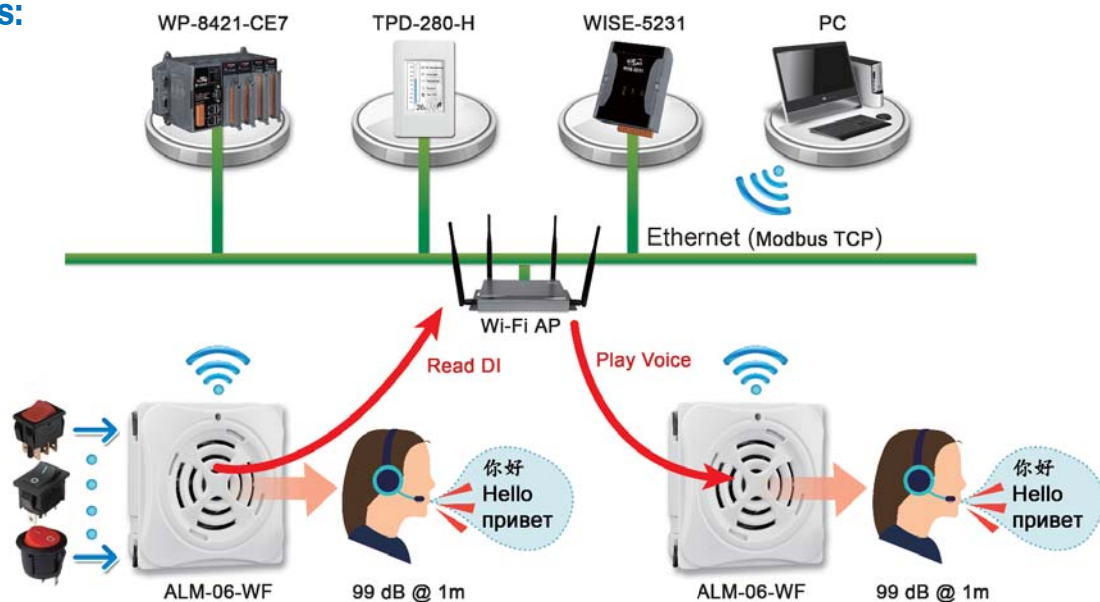

Model	Interface		Channel		Audio Format	Sound Pressure Level	Audio Output
	RS-485	Wi-Fi (2.4GHz)	DI (Dry)	Relay			
<b>ALM-06-WF</b>	—	Yes	6	1	MP3, 64x Files	99 dB @ 1 meter	3W
<b>ALM-04-MRTU</b>	Yes	—	4	(500 mA @ 50 VDC)			



# 2. WLAN Products

Classified Index		Model Name
WLAN Remote Maintenance Device		M2M-711D
CAN to Wi-Fi Converter		I-7540D-WF
Ethernet to Wi-Fi Bridge		WF-2572
WLAN Gateway		RMV-760D-MTCP
Wi-Fi Access Point		APW77BAM
Ethernet/UART to Wi-Fi Converter		IOP760
Ethernet/UART/Wi-Fi to 4G LTE Converter		IOG761AM, IOG851
Wi-Fi I/O Modules	Thermocouple, Voltage & Current Input Module	WF-2017, WF-2019
	RTD Input Module	WF-2015
	Digital I/O Module	WF-2042, WF-2051, WF-2055
	Relay Output & Digital Input Module	WF-2060, WFM-R14
	Multifunction I/O Module	WF-2026
Tiny Wi-Fi I/O Modules	Digital I/O	tWF-PD4R3, tWF-PD8, tWF-R6, tWF-PD4SR2A, tWF-PD4SR2D
	Analog I/O	tWF-AD5, tWF-TH8
	Multifunction I/O	tWF-DA1PD2R1

## ▼ WLAN Remote Maintenance Device



**M2M-711D**

### Features:

- Supports static IP/DHCP (Ad Hoc mode don't support DHCP)
- Ethernet Protocol: TCP, UDP, IP, ICMP, ARP,RARP
- Provide dynamic DNS function
- Support IEEE 802.11 b/g for Wi-Fi mode and Ad Hoc mode
- Support WEP-64,WEP-128, WPA-TKIP and WPA2-AES encryption for Wi-Fi mode
- Support WEP-64,WEP-128 encryption for Ad Hoc mode
- Provides 1~13 RF channels
- Auto control channel in AP mode
- Ad Hoc mode transmission range up to 100 m (Line of sight)
- Accommodate with M-4132, M2M-720A, M2M-710D
- Web-based administration

### Introduction:

The M2M-711D module is specially designed for the remote maintenance and upgrading the serial to network application solution. Users can choose Ethernet mode or Wi-Fi mode to do the pair connection, which provides TCP data tunneling between two serial devices. In addition to M2M-710D original features, it has the Ad Hoc mode of operation. This operation mode can be used to extend the distance of RS232/485 network without Wi-Fi AP and Ethernet Hub.

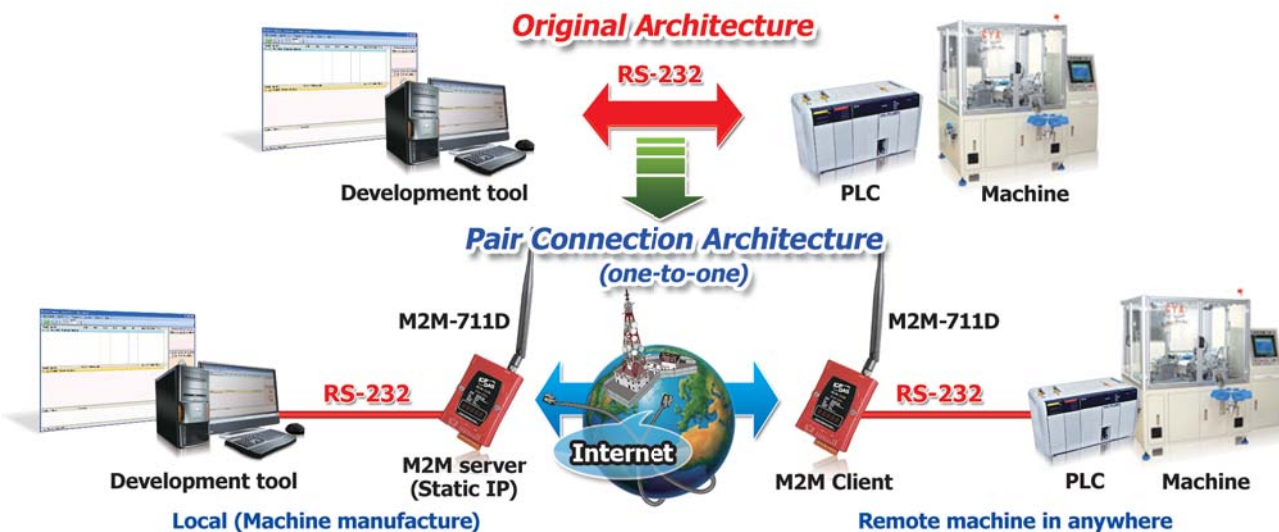

## ▼ CAN to Wi-Fi Converter



**I-7540D-WF**

### Features:

- IEEE 802.11b/g compliant
- Wireless data transmission via WLAN
- Two different operation modes: infrastructure and ad-hoc
- Point to point or point to multi-points connection via WLAN
- Support WEP, WPA and WPA2 encryption for WLAN
- CAN 2.0A/2.0B compliant
- Connect CAN networks via a WLAN bridge
- Communication efficiency:  
one-way is up to 700 fps (client->server, server->client),  
two-way 350 fps (client<=>server)
- Wireless communication: 100 m (Without PA) / 300 m (With PA)

### Introduction:

I-7540D-WF supports the wireless transmission of CAN data between various CAN networks or a CAN network and a WLAN network according to the 802.11b/g standard. I-7540D-WF is highly suitable for connecting mobile (e.g., vehicles or machines) or stationary CAN networks and often used for short ranges up to 100 or 300 m. (TCP data protocols are available.) Using an appropriately configured router, CAN data can be transmitted over the Internet. There are two operating modes in the I-7540D-WF: access point mode and ad-hoc mode. In the access point mode, the data connection takes place over one or several WLAN access points that are often part of the company's internal IT infrastructure. In the ad-hoc mode, a direct connection is established between a single I-7540D-WF device and a PC (with an integrated WLAN interface), or with a second I-7540D-WF device. In this way, the I-7540D-WF can be used as a CAN diagnosis interface. The wireless connection that established between two I-7540D-WF can be used instead of a cable, and enables the connection of CAN networks.

### ● Point to Point connection (Ad-Hoc)

Single I-7540D-WF module can be directly connected to another I-7540D-WF.

**Ad hoc mode  
(AP is not necessary)**



### ● Point to Multi-points connection (Supports up to 3 clients)

I-7540D-WF is transmitted by Wi-Fi Access point and other I-7540D-WF.



## ▼ WLAN Gateway



### RMV-760D-MTCP

Modbus TCP/RTU Data-Exchange with Wi-Fi Interface Gateway

#### Features:

- Supports pair-connection applications
- Application Modes: Virtual COM, MB TCP Server/Client, MB RTU Master/Slave
- Supports static IP/DHCP (Ad Hoc mode don't support DHCP)
- Ethernet Protocol: TCP, UDP, IP, ICMP, ARP, RARP
- Support IEEE 802.11 b/g for Wi-Fi mode and Ad Hoc mode
- Support WEP-64, WEP-128, WPA-TKIP and WPA2-AES encryption for Wi-Fi mode
- Support WEP-64, WEP-128 encryption for Ad Hoc mode
- Auto control channel in AP mode

RMV-760D-MTCP is a Modbus TCP/RTU gateway. It exchanges Modbus command from Modbus TCP/RTU master to Modbus RTU/TCP slave. Modbus TCP command can be transceived not only Ethernet port but also Wi-Fi interface. It supports VxComm and Pair-Connection functions. Users can choose Ethernet mode or Wi-Fi mode to implement the pair connection, which provides TCP data tunneling between two serial devices.

#### ▼ Description of connections:

##### • Data exchange about Modbus TCP and Modbus RTU:

Exchanging the data between Modbus TCP and Modbus RTU.

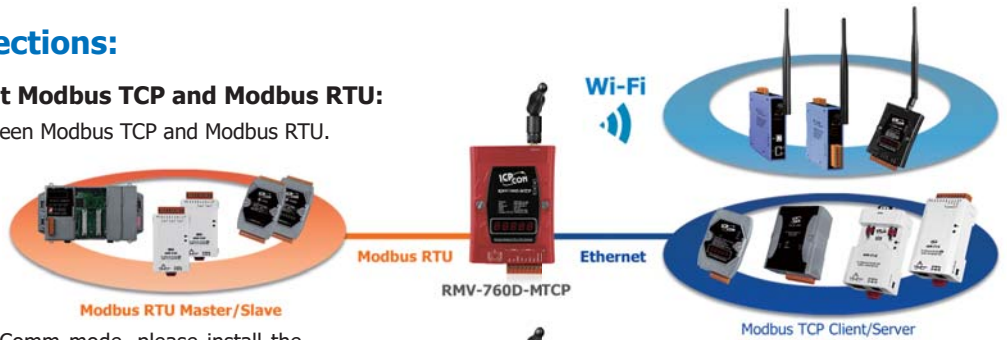

##### • VxComm mode:

If user have to use in VxComm mode, please install the VxComm driver first, and then it can start to be use.



##### • Pair-Connection mode:

This mode requires two devices to work together: Pair-Connection Server and Pair-Connection Client.

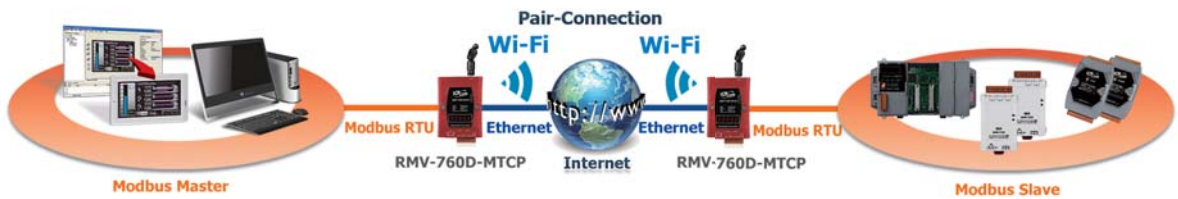

#### ▼ Transmission Type:

##### • Ethernet:

Use the RJ-45 network route to connect to the Internet and transfer data to another device.

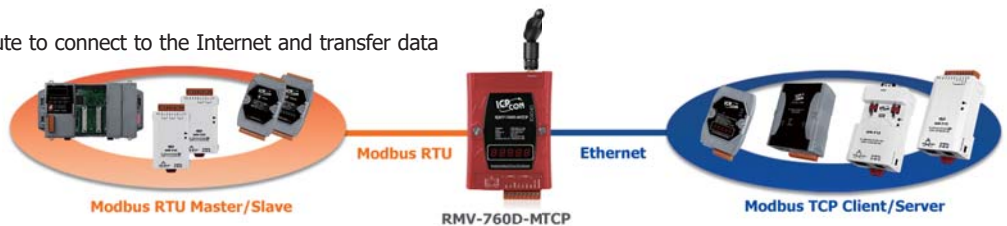

##### • AP:

Use the Wi-Fi AP to connect to the Internet, and then transfer data.



## WF-2200



## ▼ Wi-Fi I/O Modules

The WF-2000 and tWF series are Wi-Fi I/O modules. Connection comply with the IEEE 802.11 a/b/g/n standards. With the popularity of 802.11 network infrastructure. The WF-2000 and tWF series support Modbus/TCP and UDP protocol and the network encryption configuration, which make perfect integration to SCADA software and offer easy and safe access for users from anytime and anywhere.

### ✓ RTD, Thermocouple, Voltage & Current Input Module

Model Name	AI		
	Channel	Voltage and Current Input	Sensor Input
WF-2215	6	-	RTD: Pt100, Pt1000, Ni120, Cu100, Cu1000
WF-2217	8/16 (DIFF/SE)	±150 mV, ±500 mV, ±1 V, ±5 V, ±10 V, 0 ~ +20 mA, +4 ~ +20 mA, ±20 mA	-
WF-2219	10	±15 mV, ±50 mV, ±100 mV, ±500 mV, ±1 V, ±2.5 V, ±5 V, ±10 V, ±20 mA	Thermocouple: J, K, T, E, R, S, B, N, C

### ✓ Digital I/O Module

Model Name	DI/Counter			DO			
	Channel	Contact	Sink/Source	Channel	Type	Sink/Source	Max. Load Current @ 25°C
WF-2242	-	-	-	16	Open Collector	Sink	700 mA/channel
WF-2251	16	Dry, Wet	Dry: Source Wet: Sink/Source	-	-	-	-
WF-2255	8	Dry, Wet	Dry: Source Wet: Sink/Source	8	Open Collector	Sink	700 mA/channel

### ✓ Relay Output & Digital Input Module

Model Name	DI/Counter			Relay Output		
	Channel	Contact	Sink/Source	Channel	Relay (Type)	Max. Load Current @ 25°C
WF-2060	6	Dry, Wet	Dry: Source Wet: Sink/Source	6	Power Relay (Form A)	5.0 A/channel
WFM-R14	-	-	-	14	2 Power Relays (Form A) 12 Power Relays (Form C)	5.0 A/channel (Form A) 6.0 A/channel (Form C)

### ✓ Multifunction Module

Model Name	AI		AO		DI/Counter		DO	
	Channel	Voltage and Current Input	Channel	Voltage and Current Output	Channel	Contact	Channel	Type
WF-2226	5	±150 mV, ±500 mV, ±1 V, ±5 V, ±10 V, 0 ~ 20 mA, 4 ~ 20 mA, ±20 mA	2	0 ~ 5 V, 0 ~ 10 V, ±5 V, ±10 V, 0 ~ 20 mA, 4 ~ 20 mA	2	Dry (Source)	3	Open Collector (Sink)

## Application Architecture:



## ✓ Tiny Series Digital I/O Module

Model Name	DI		DO	
	Channel	Contact	Channel	Type
tWF-PD4R3	4	Dry	3	Relay DC30V/2A, AC250V/0.25A
tWF-PD4SR2A	4	Dry	2	AC SSR AC240V/1.5A
tWF-PD4SR2D	4	Dry	2	DC SSR DC3 ~ 30V/1A
tWF-R6	-	-	6	Relay DC30V/2A, AC250V/0.25A
tWF-PD8	8	Dry	-	-

## ✓ Tiny Series Multifunction I/O Module

Model Name	AO		DI		Relay Output	
	Channel	Voltage & Current Output	Channel	Type	Channel	Type
tWF-DA1PD2R1	1	0 ~ 10 V, 0 ~ 20 mA	2	Dry Contact	1	Power Relay

## ✓ Tiny Series Thermistor & Voltage Input Module

Model Name	AI		
	Channel	Voltage & Current Input	Sensor
tWF-AD5	5	±1 V, ±2.5 V, ±5 V, ±10 V	-
tWF-TH8	8	-	Thermistor

## Multi-platform Remote Access Software:

Real-time data from the WF-2000 I/O module can be accessed from anywhere and at any time using the WF IO Utility and iOS App

### Download:

Download by iTunes App Store Search keyword: WF2200

### Compatibility:

Requires iOS 8.1 or later. Compatible with iPhone, iPad, and iPod touch

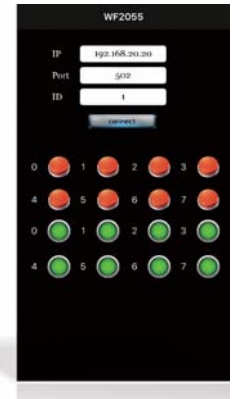

## Dimensions (Units: mm)

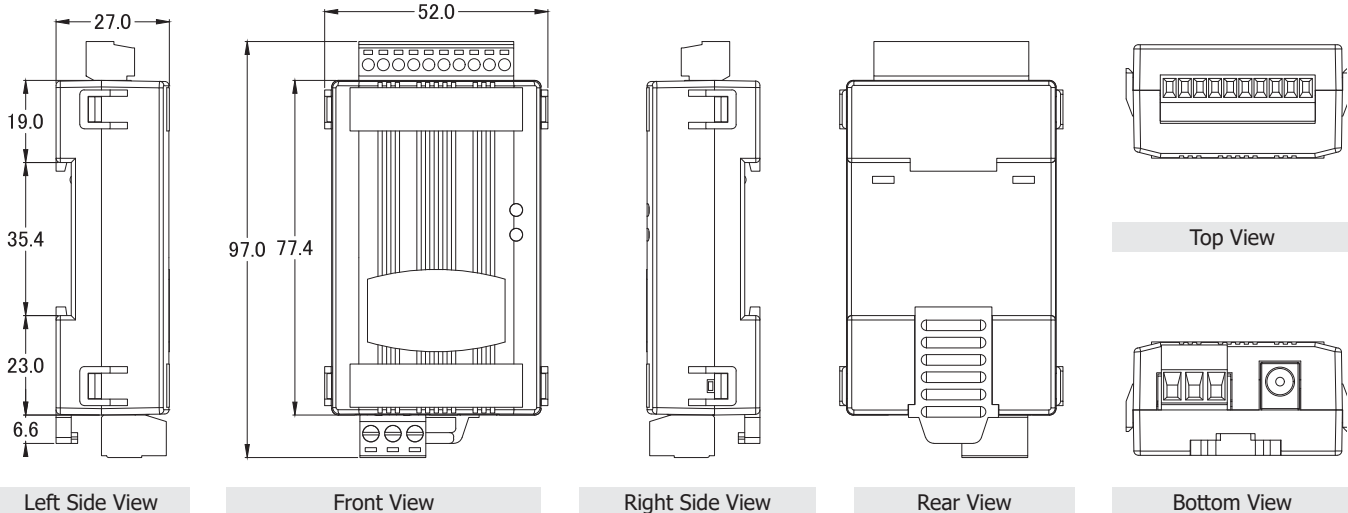



## ▼ Wi-Fi Access Point



**APW77BAM**

### Features:

- Thin AP
- Wall-Mount Wi-Fi Access Point
- Support Wi-Fi MIMO 2T2R
- IEEE 802.11a/b/g/n/ac Wi-Fi Compliance
- Configurable AP Transmit Power and Channel
- Supports WEP, WPA, WPA2, WPA-PSK, WPA2-PSK and 802.1x
- Segmented guest and corporate access with multiple SSIDs
- One IEEE 802.3 af (PoE), or DC12V/1A
- Concurrent Dual Band with 2.4/5 GHz
- WDS/Repeater/Client Modes
- Website Configuration Interface

### Introduction:

The APW77BAM is designed for medium-sized businesses to extend the existing networks and has the ability to operate in different modes and can be used in a wide variety of wireless applications. Its Universal Repeater Mode not only has an easier way for setup, but also provides better performance and compatibility to create a larger wireless network infrastructure by linking up other access points. It also supports Multiple-SSID function to simultaneously emulate 8 APs with different SSIDs and separate packets via VLAN IDs.

### Connection Diagram:

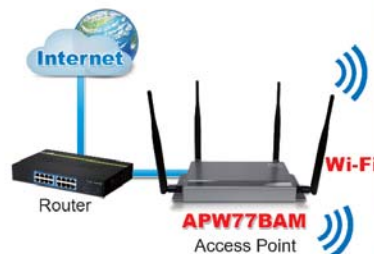

### Application Fields



### Applications:

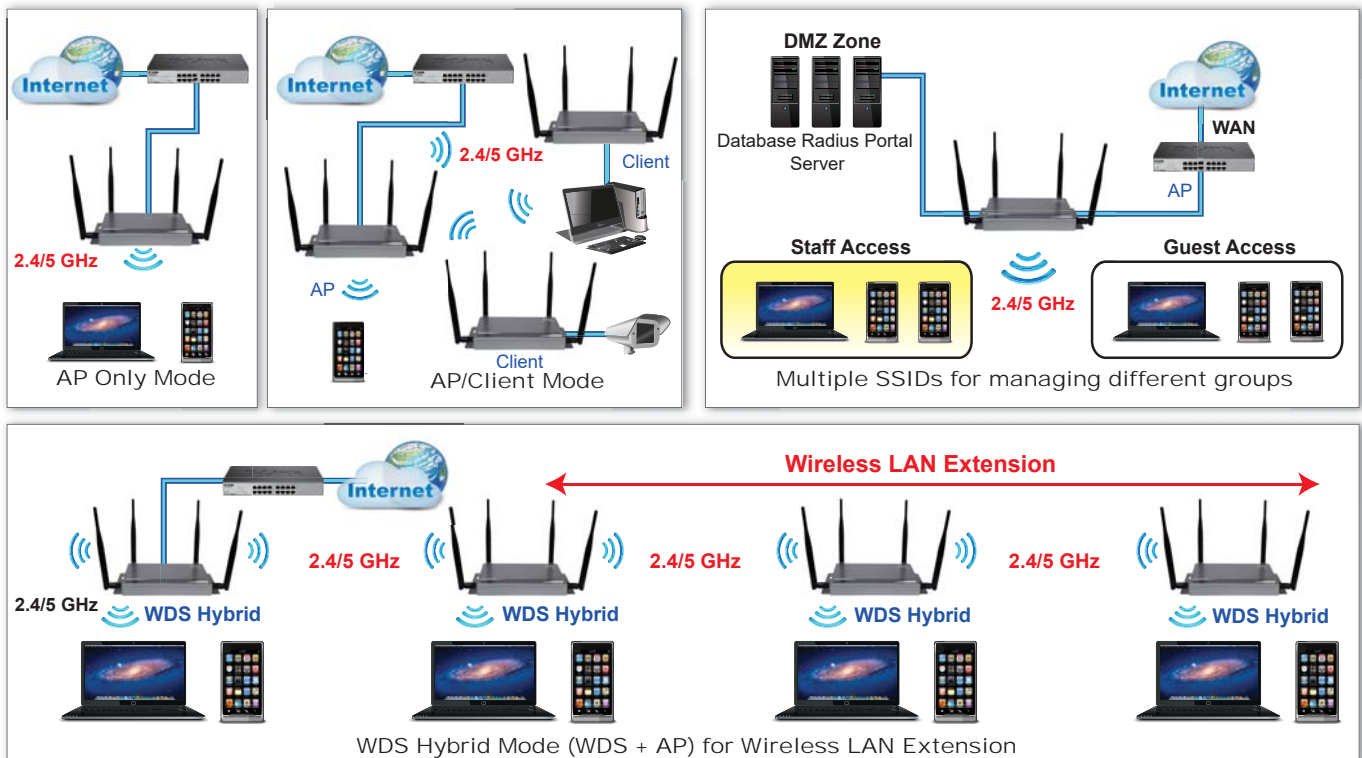

## ▼ Ethernet / UART to Wi-Fi Converter



**IOP760**  
Available Soon

### Features:

- Support Wi-Fi dual bands 2.4/5 GHz
- Compatible with IEEE 802.11 a/b/g/n/ac standard
- Support different connection modes: AP, WDS and AP Clients
- Wi-Fi/Ethernet/RS-232/RS-485 bridge
- Support two Ethernet Ports
- Wi-Fi roaming
- Modbus RTU to Modbus TCP gateway
- Support CLI (Command Line Interface) interface
- Website Configuration Interface

### Introduction:

The IOP760 is absolutely the right choice for wireless M2M (Machine-to-Machine) applications. With built-in high performance IEEE802.11a/b/g/n/ac compliant Wi-Fi uplink or multi-mode access point function. IOP760 is a wireless converter. The data can be exchanged via the three different interfaces Wi-Fi, Ethernet and UART. Users can select IEEE 802.11 b/g/n for 2.4GHz connections or select IEEE 802.11 a/ac for 5GHz connections. When the Wi-Fi strength is lower than the threshold setting, IOP760 can connect to another stronger one via the roaming function. The IOP760 has two Ethernet interfaces that can connect to two Ethernet devices. The UART interfaces supports RS-232 and RS-485. The data can be sent directly or formed by Modbus protocol.

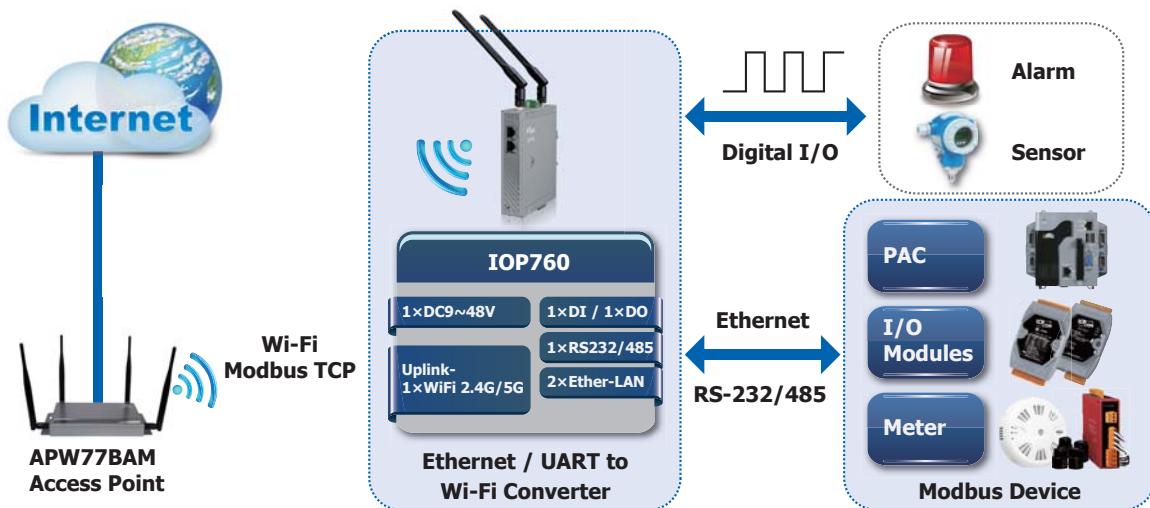

### Applications:

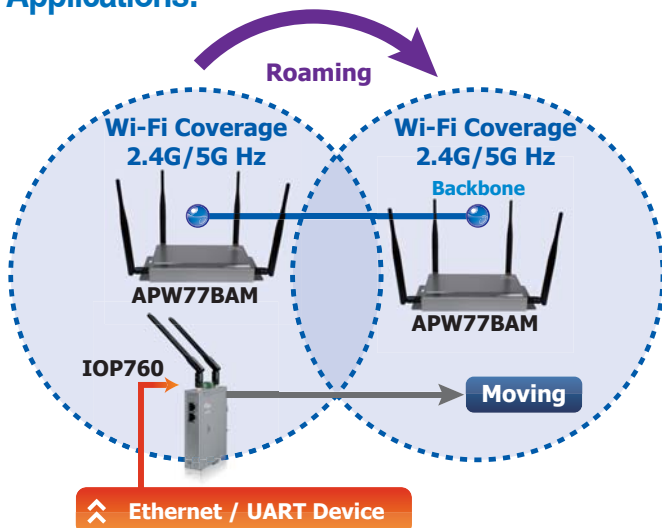

### Function:

- To deploy an Ethernet/UART to Wi-Fi Converter for industrial automation.

### Description:

- The easiest way to deploy an Ethernet/UART to Wi-Fi Converter for connecting your industrial automation or telemetry equipments to the local / remote management center with wireless solution.
- With 802.11n/ac (2.4G/5GHz selectable) as connection interface, it is simple to connect with existing wireless local data network.
- The most cost-effective product for you with robust design for secure internet access, variable voltage range, wide temperature range.
- Wi-Fi Roaming applications with APW77BAM

## ▼ Ethernet / UART / Wi-Fi to 4G LTE Converter



**IOG761AM**  
Available Soon



**IOG851**  
Available Soon

### Features:

- 1 × embedded LTE module with dual-SIM failover for reliable and efficient access
- 3(4) × FE LAN port with tag based and port based VLANs easily to group control and relocate traffic pattern.
- Wi-Fi standard
  - IOG761AM supports IEEE 802.11 n 2T2R (2.4G Hz)
  - IOG851 supports IEEE 802.11n/ac 2T2R (2.4G/5G Hz selectable)
- 1 × DB9 (RS232/RS485) interface for Modbus RTU/ASCII and various serial communication protocol, and 1 × DI, 1 × DO for device triggering or event reporting

### Introduction:

The IOG761AM and IOG851 are loaded with powerful features for complex and demanding business and M2M (Machine to Machine) applications. The redundancy design in fallback 9 ~ 48 VDC power terminal, dual SIM cards and VRRP function makes the device as a back-up in power, network connection and data transmission without lost.

### Applications:

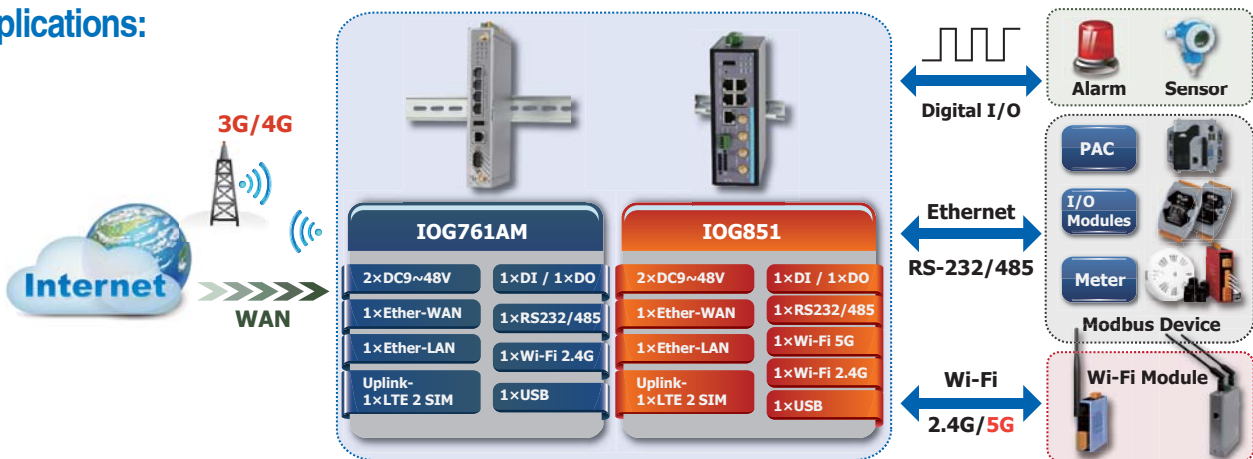

Device	IOG761AM	IOG851
<b>Model Name</b>	IOG761AM	IOG851
Pictures		
<b>Device Interface</b>		
Uplink	1 × LTE module (dual SIM), 1 × RJ45 FE (configurable)	
Ethernet	3 (4) × RJ45 FE	
Wi-Fi	IEEE802.11n 2T2R (2.4G Hz)	IEEE802.11n/ac 2T2R (2.4G/5G Hz selectable)
Communication Bus	1 × DB9 RS232/RS485	
I/O	1 × DI ("Logic 0": 0 ~ 2V, "Logic 1": 5V ~ 30V), 1 × DO (Relay Mode, up to 30V / 1A)	
Management Port	1 × RJ12 RS232 (Console)	
Log Storage	1 × USB 2.0	
Cellular Band	LTE: 800/900/1800/2100/2300/2600 MHz, UMTS: 850/900/1900/2100 MHz, GPRS/EDGE: 850/900/1800/1900 MHz	
Antenna	2 × 5dBi detachable ant. (Wi-Fi), 2 × 3dBi detachable ant. (3G/4G)	
Power Source	Dual DC 9V ~ 48V	

## ▼ Wi-Fi solution for AGV system

The AGV (Automated Guided Vehicle) system is more and more popular in the warehouse management. People can control their AGV system via the wireless interface. Wi-Fi is the proper media for the AGV application. It provides the large bandwidth transmission for the film of the camera. It is also expandable. If you want to extend your communication distance, you can add more Wi-Fi devices for the larger coverage.

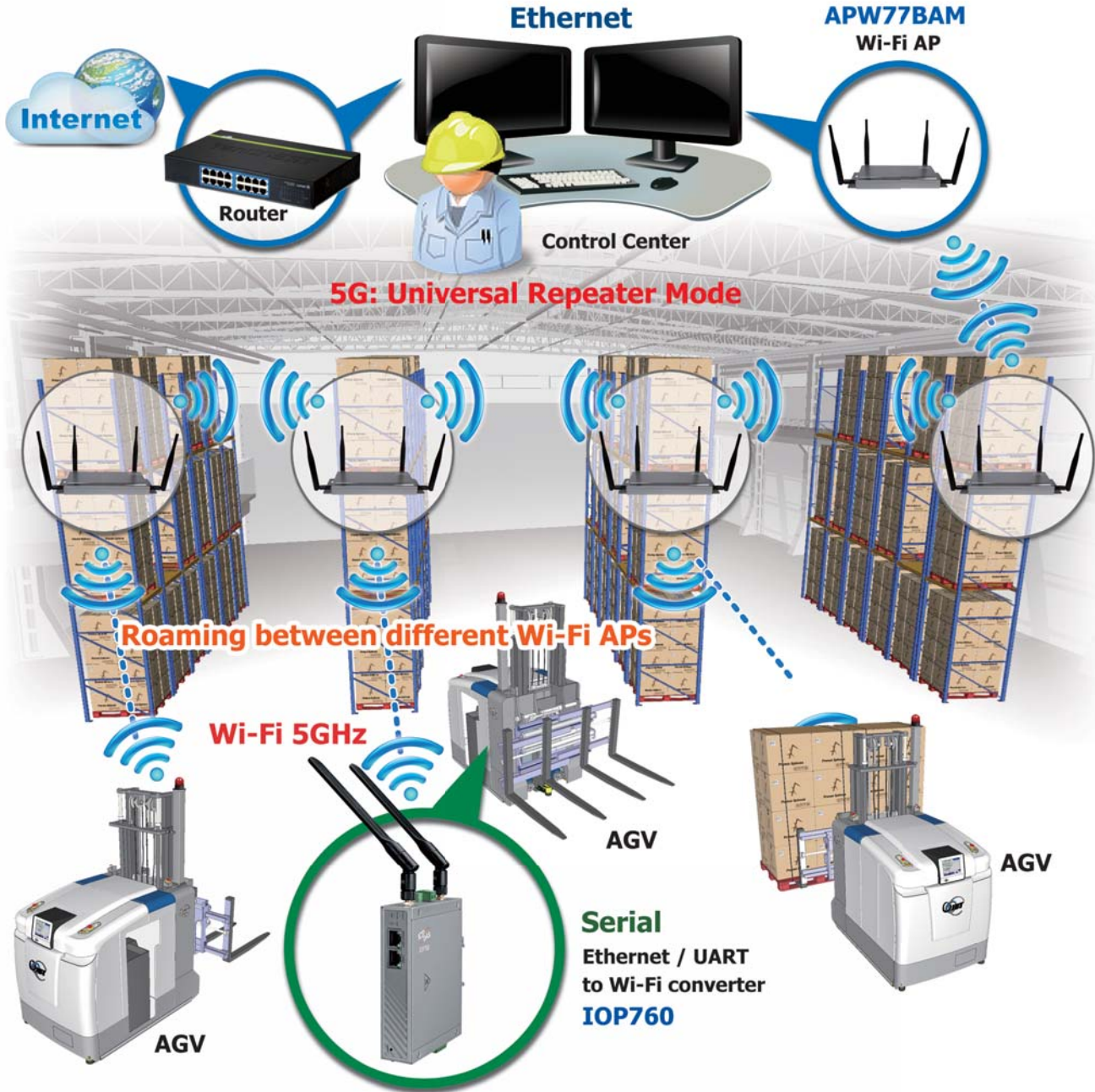

ICPDAS provides a better Wi-Fi solution for the AGV system. IOP760 and APW77BAM support IEEE 802.11 ac (5GHz) and Wi-Fi roaming. IEEE 802.11 ac works in the 5GHz band, and it does not be influenced by 2.4GHz (802.11 b/g/n) or another ISM band devices. Wi-Fi roaming can make the communication stable between APs (APW77BAM). APW77BAM is a thin AP. It is convenient for monitoring and extending the Wi-Fi coverage range. The Wi-Fi converter IOP760 provides one RS-232 and one Ethernet interface. The AGV can work via different interface. That is adaptable and convenient for AGV application.

Model	Description
<b>APW77BAM CR</b>	Wi-Fi Access Point (with category A plug type)
<b>APW77BAM-EU CR</b>	Wi-Fi Access Point (with category E plug type)
<b>IOP760 CR</b>	Ethernet/UART to Wi-Fi Converter (with category A plug type)

## ▼ IOP760 Application Mode

The IOP760 is a powerful wireless M2M (Machine-to-Machine) solution. Users can connect all your devices wirelessly while the wire deploying is too difficult or not feasible. There are 4 popular application modes: Modbus Router, Fieldbus Bridge, Point-to-Point and Roaming Threshold.

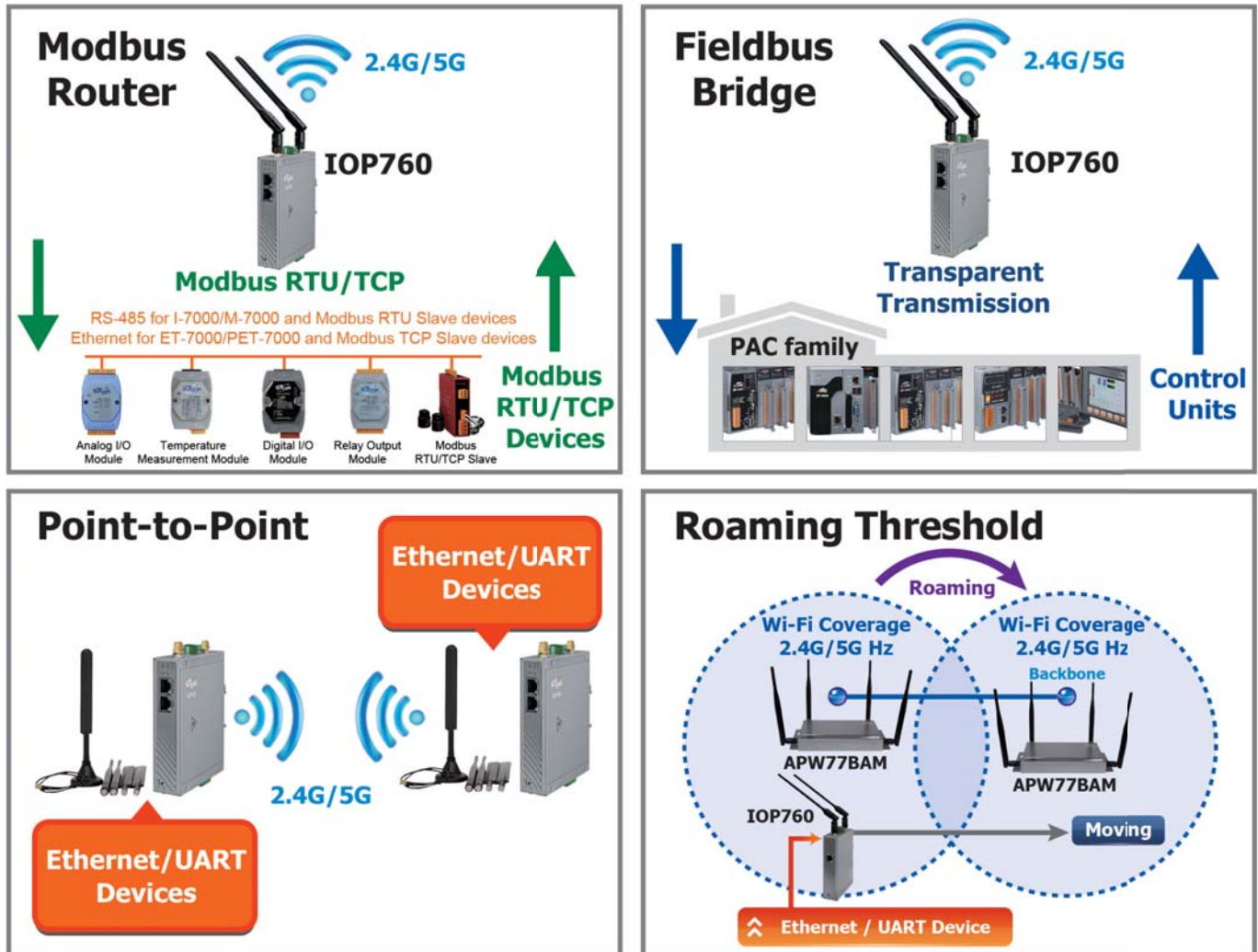

### (1) Modbus Router

The IOP760 is a Modbus master or slave. All the Modbus RTU and TCP/IP devices can publish their data to Wi-Fi via IOP760.

### (2) Fieldbus Bridge

In the SCADA system, the vendor-defined command is common to control units. The transparent transmission is required when these control units make connection with Wi-Fi.

### (3) Point-to-Point

In the out-door application, users are hard to construct the Ethernet environment. All the devices can establish the wireless connection via IOP760 conveniently.





### (4) Roaming Threshold

The vehicle solution is more and more popular. "How to build a stable wireless environment" is an important issue. ICPDAS provides a Wi-Fi solution for the roaming system: IOP760 and APW77BAM. The APW77BAM is a Wi-Fi AP (access point) with built-in roaming function. Users can set the Wi-Fi signal strength threshold in the IOP760. If the Wi-Fi signal strength is lower than the threshold, the IOP760 can connect to another APW77BAM automatically.

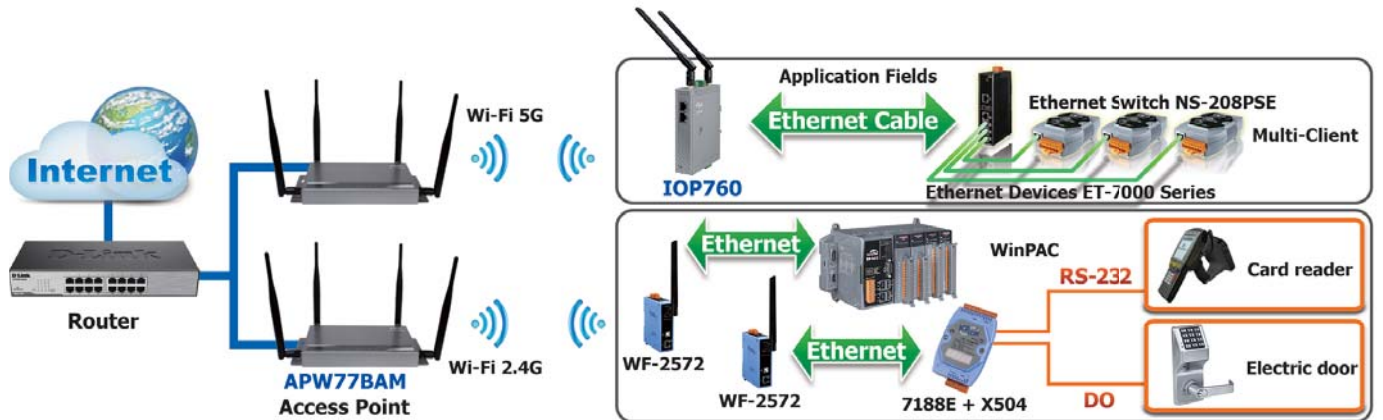
## ▼ Wi-Fi Converter Comparison

In the factory solution, WF-2572, IOP760 and IOG761AM provide a complete solution for the wireless coverage.



Model Name		WF-2572	WF-2572M	IOP760	IOG761AM	IOG851
Pictures		 Plastic Case	 Metal Case			
Wireless Standards		IEEE 802.11 a/b/g		IEEE 802.11 b/g/n/ac	IEEE 802.11 b/g/n	IEEE 802.11 a/b/g/n/ac
Bandwidth	Wi-Fi	2.4G/5GHz			2.4G	2.4G/ 5G Hz
	Cellular	-		-	LTE: 800/900/1800/2100/2600 MHz, UMTS: 850/900/1900/2100 MHz, GPRS/EDGE: 850/900/1800/1900 MHz	
Antenna			1	2	4 (2 × Wi-Fi, 2 × 3G/LTE)	
Modbus Protocol			-		Yes	
Interface	Wi-Fi			Yes		
	Ethernet		1	2	5	5
	UART		-		RS-232/RS-485	
	3/4G LTE		-	-		Yes
Bridge Mode	Wi-Fi/Ethernet			Yes		
	Wi-Fi/UART		-		Yes	
	Ethernet/UART		-		Yes	
	LTE/Ethernet		-		Yes	
	LTE/Wi-Fi		-	-		Yes
	LTE/UART		-	-		Yes
Configuration Interface		Yes (Limit-AP Mode) Utility			Yes Web Server	

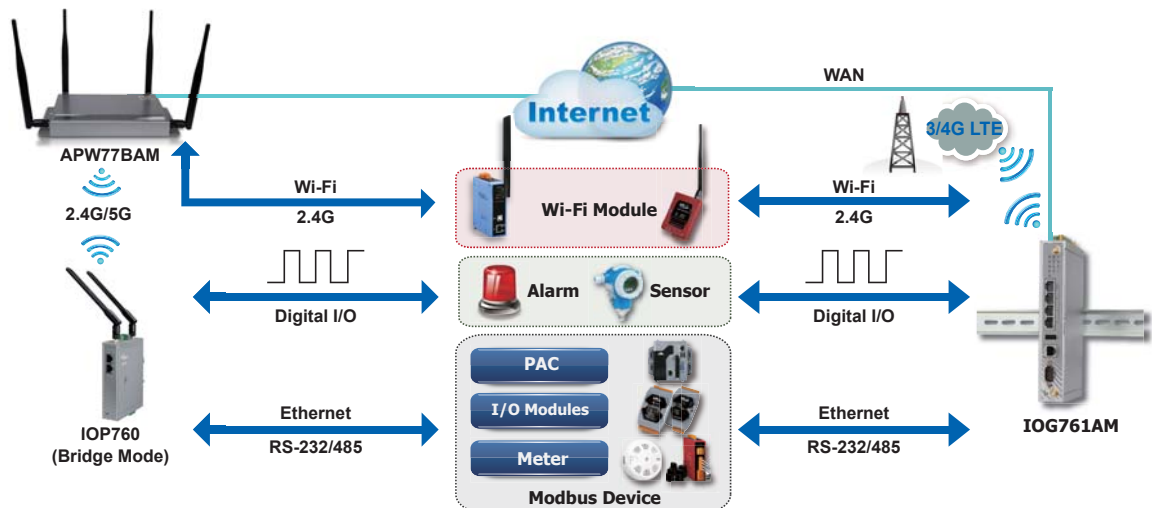





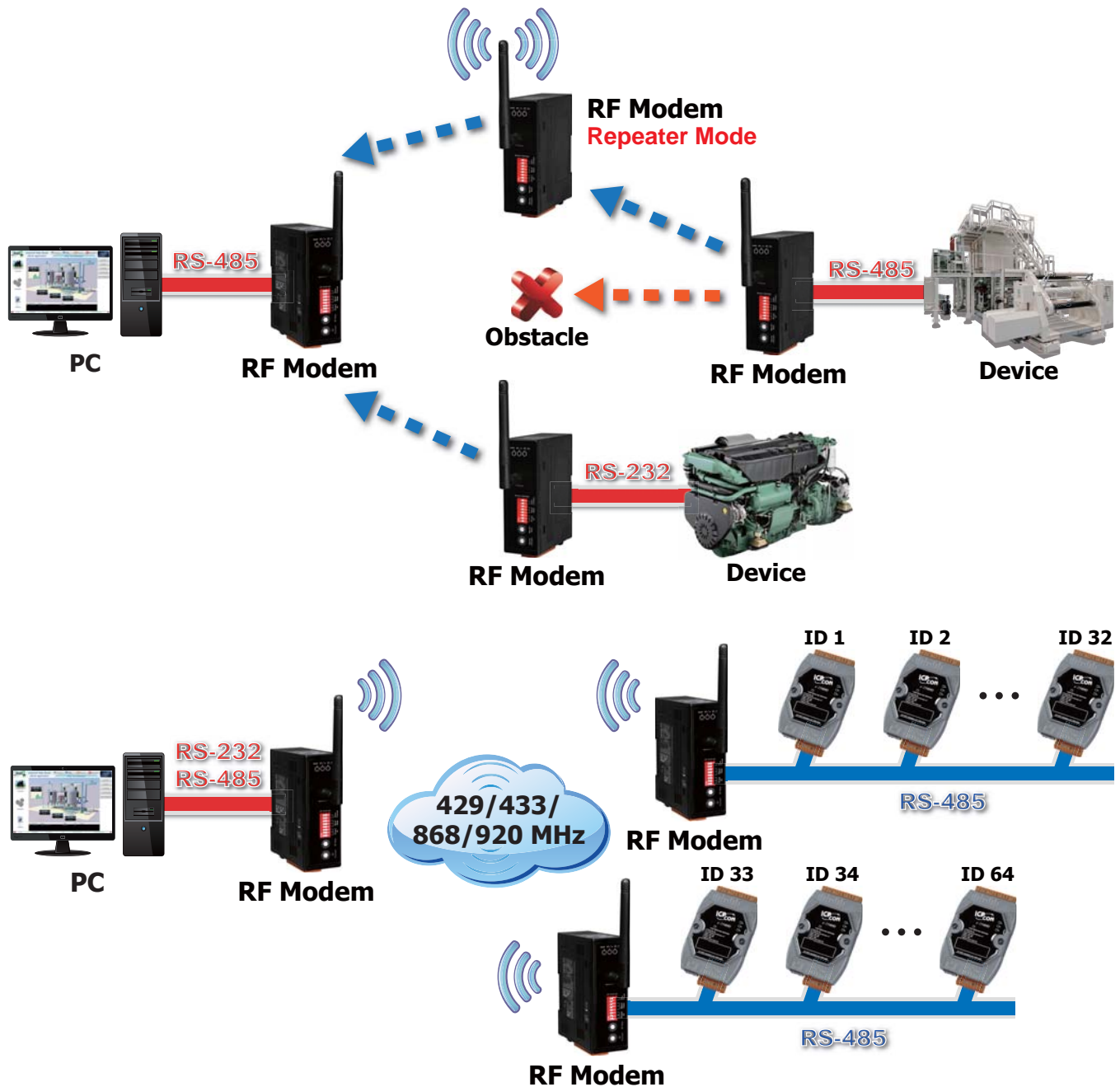

# 3. Radio Modem

ICP DAS provides RFU and LRA series wireless modem which is designed for data acquisition and control applications between a host and remote sensors. It is also useful for those applications where the installation of cable wire is inconvenient. The wireless modem series is a spread spectrum radio modem with an RS-232 or RS-485 or Ethernet interface port. The module can be used not only in peer to peer mode, but also in a multi point structure.







**Product Specification Comparison:**

Model Name	RFU-400	RFU-433	RFU-2400	tRFU-2400	LRA-900	LRA-900-E
Pictures						
RF Frequency	429/433 MHz	433 MHz	2.4G		864 ~ 871.5MHz, 915 ~ 922.5MHz	
RF Channel	16 for each frequency	16		1 for each frequency		
Group ID	0 ~ 7		0 ~ 15		1 ~ 254	
Modulation	2GFSK		OQPSK		LoRa	
Antenna Gain	0 dBi		5 dBi	3 dBi	2 dBi	
Antenna Type	Whip			PCB	Whip	
RF Baudrate	115.2 kbps ~ 650 bps	57.6 kbps ~ 650 bps	250 kbps		10 kbps ~ 250 bps	
Temporary Buffer Size	512 Bytes		2560 Bytes		200 bytes	
Transmit Power (Max.)	19 dBm		19 dBm	17 dBm	15 dBm	
Transmission Distance (LoS)	1 km @ 9.6k bps @ 19 dBm		700 m @ 250 kbps @ 11 dBm	180 m @ 250 kbps @ 11 dBm	1.5 km @ 10 kbps @ 15 dBm	
Hopping	1 Hop		-		-	
Interface	1 x RS-232, 1 x RS-485		1 x RS-232, 1 x RS-422, 1 x RS-485		1 x RS-232, 1 x RS-485	1 x Ethernet

**External Antenna Comparison:**

Model Name	Radio		
	External Antenna Base	External Antenna	External Cable
RFU-400	ANT-Base-01	-	3S001-2
RFU-433	ANT-Base-02	-	3S001-1 3S003-1
RFU-2400		ANT-8 / ANT-18	
tRFU-2400		-	
LRA-900		-	
LRA-900-E		-	



Omni Directional External Antenna	Directional External Antenna	Antenna Base	Cable	
		 Magnetic Disk Base Dimension (L × W × H): 1500 mm × φ60 × 42 mm	 RG58A/U, 1 meter	 RG58A/U, 3 meter
<b>ANT-8</b> Frequency: 2.4 ~ 2.5 GHz Gain : 8 dBi Length: φ35 × 420 mm Cable: 1 meter long N type male to RP-SMA male	<b>ANT-18</b> Frequency: 2.4 ~ 2.5 GHz Gain : 18 dBi Dimension (L × W × H): 270 mm × 205 mm × 15 mm Cable: 1 meter long N type male to RP-SMA male	<b>ANT-Base-01</b> SMA male to SMA female  <b>ANT-Base-02</b> RP-SMA male to RP-SMA female	<b>3S001-1</b> RP-SMA male to RP-SMA female  <b>3S001-2</b> SMA male to SMA female	<b>3S003-1</b> RP-SMA male to RP-SMA female

## Rainwater monitoring and recovery system

The development of water resources is becoming more and more difficult. Therefore, the recovery and reuse of water resources has become an important issue for high water-consuming industries. And rainwater recovery is one of them. Set up a pH meter and a conductivity meter at each rainwater groove. Using ICP DAS' WISE to read the pH and conductivity of the rainwater to decide the water quality. According to the water quality switch the water valve to collect or discharge the rainwater. Finally pass the water quality, volume and related parameters to the control center through RFU-433 for recording and analysis. And the collected rainwater can be used as cooling water for high-temperature equipment.

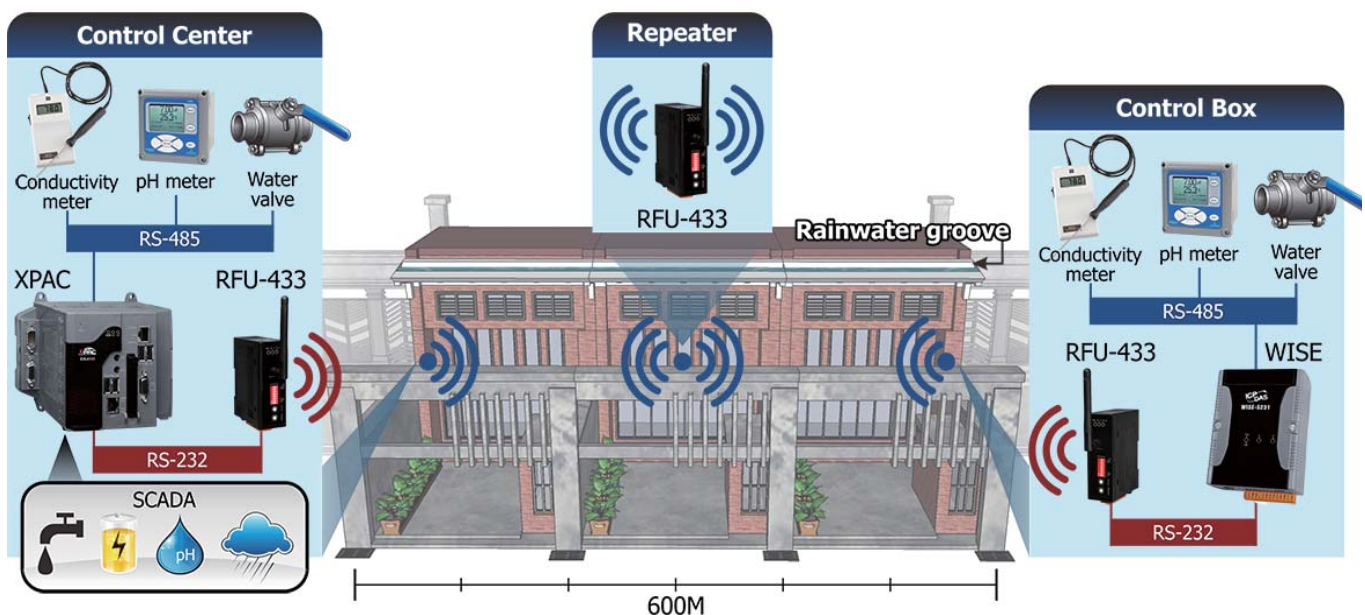

## Factory power information return application:

With the scarcity of energy and energy prices have been rising, countries around the world have enacted various energy-saving and carbon-reduction related laws and regulations. For factories with huge power consumption, there is an urgent need to reduce power costs and control power demand to stabilize the power system and maintain the normal operation of the production line.

Use the remote wireless LRA-900 module developed by ICP DAS and SCADA software of the factory power monitoring system, and carry out the overall integration and analysis of the power information of each factory area. In this way, it can be notified immediately when the power is abnormal, and the equipment can be unloaded immediately when the contracted capacity is predicted to be exceeded, avoiding over-contract fines, and formulating the best power usage plan to effectively improve the quality of the power supply in the plant.

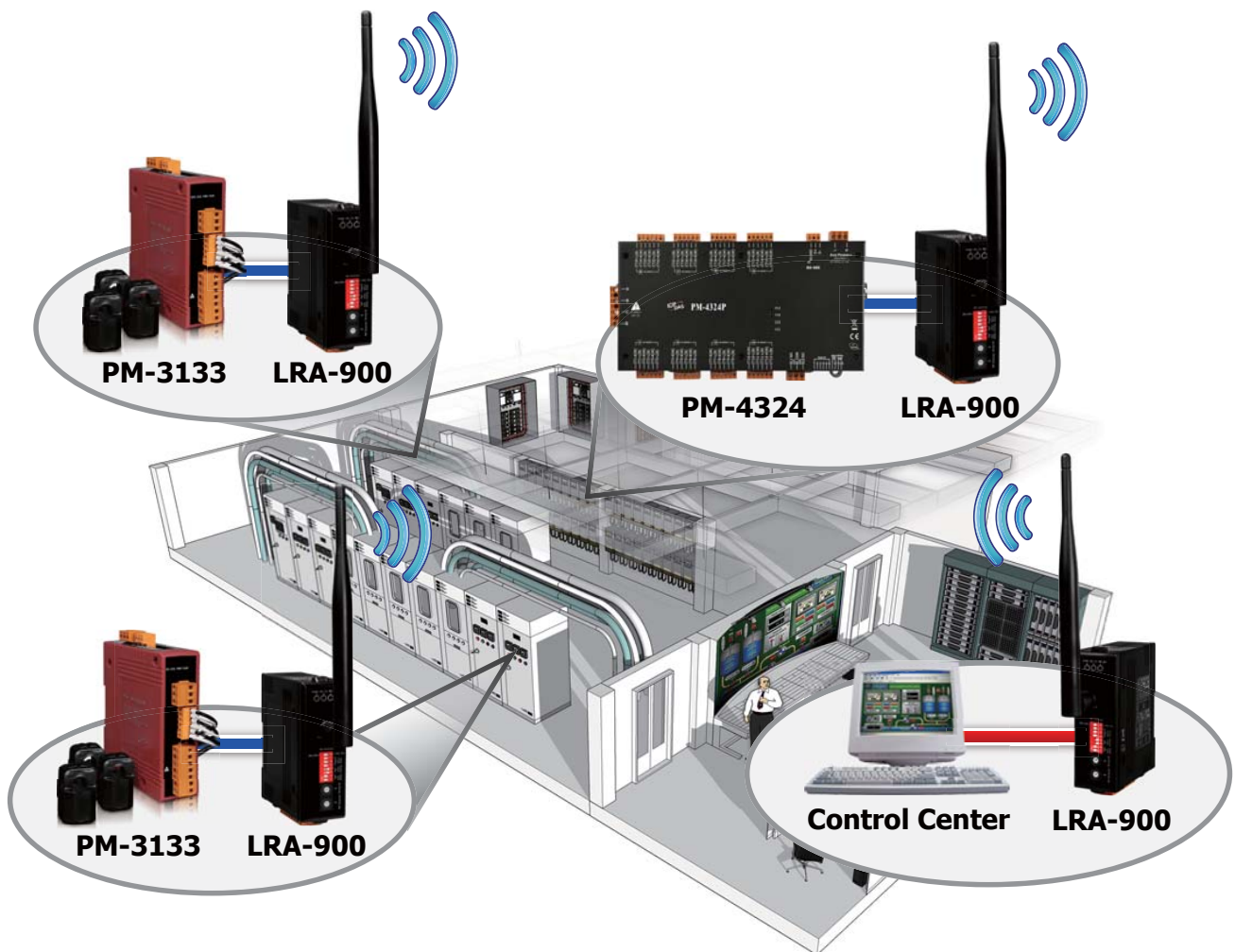





# 4. 3G/4G Products

## SMS Remote Module

ICP DAS provides various intelligent 3G/4G modules and gateway, SMS-5xx Series. The Module is GSM remote control and alarm system allows users to use their mobile phone to monitor and control the business from any location. Its alarm facilities provide a flexible way to distribute critical alarm information to any number of mobile phone users. The Gateway allows user to access mobile phone by using standard protocol, such as Modbus.



Model Name	SMS-530	SMS-531	SMS-534	GTP-541M
Pictures				
Interface	2 × RS-232	2 × RS-232 1 × RS-485	1 × RS-232 1 × RS-485	1 × RS-232 1 × RS-485
Frequency (MHz)	2G (GSM/GPRS): 850/900/1800/1900 3G (UMTS/HSDPA/HSUPA): 850/900/1900/2100			2G (GSM/GPRS): 900/1800 3G (UMTS/HSDPA/HSUPA): 900/2100 4G (LTE-FDD)B1/B3/B8 4G (LTE-TDD)B38/B39/B40/B41
I/O	2 × DO 10 × DI	-	2 × DO 6 × DI 1 × AI	2 × DO 5 × DI 4 × AI
Alarm	Yes (SMS)	Yes (SMS, Voice)	Yes (SMS, Voice)	Yes (SMS)
Micro SD	-	Yes	Yes	Yes
Battery Backup	Yes	-	Yes	-
Transparent Communication	SMS	Modbus RTU	SMS	Modbus RTU/ SMS
VxComm		-		Yes
3G Router		-		-

## SMS Database System:

- Quickly and easily build a SMS-53x management system
- Support MS SQL Server and MS Access 2003 Database
- Support Windows 2K/XP/7/8/10
- Support SMS-530, SMS-531, and SMS-534
- Support filter function that enables to receive SMS messages by specific phone numbers
- Allow to view real-time or historical data of SMS messages sent by SMS-53x series and GTP-541M
- Provide backup mechanism in local sites: when experiencing unexpected disconnection and not able to transmit and store data in remote SQL Server database, the data will be safely kept in local sites
- Allow to view real-time or historical data of SMS messages sent by SMS-53x series and GTP-541M

## Introduction:

SMS Database System is a software allows to manage remote SMS-53x series more efficiently. SMS-53x series are intelligent GSM controllers great for use in industry applications; they feature easy-to-use interface, SMS tunnel function voice communication and can be powered with an external power supply or Li-Battery. They support UNICODE and 7 bit format that allows users to send SMS messages in various languages; the SMS messages can be sent at user-defined time or whenever a predefined DI/counter event is triggered. With SMS Database System, it enables remote monitoring and database system for SMS-53x, therefore, allows the 3rd party software tools being easily integrated with SMS-53x series as well as users' applications.

## Applications (Remote Maintenance):





## Version Comparison:

Version	Max. Phone Number Supported	Database	License
SMS Database System Lite v1.0	3	MS Access 2003	Free
SMS Database System Pro v1.0	Unlimited	MS SQL Server / MS Access 2003	Charge



# 3G/4G Modem

ICP DAS provides various industrial Quad-band 2G or Tri-band 3G or LTE 4G modem. The modems utilize the 2G/3G/4G network for convenient and inexpensive data transfer from remote instruments, meters, computers or control systems in either live data or packet data. The modems have the integrated TCP/IP stack so that even simple controllers with serial communications ports can be connected to the modem without the need for special driver implementation.

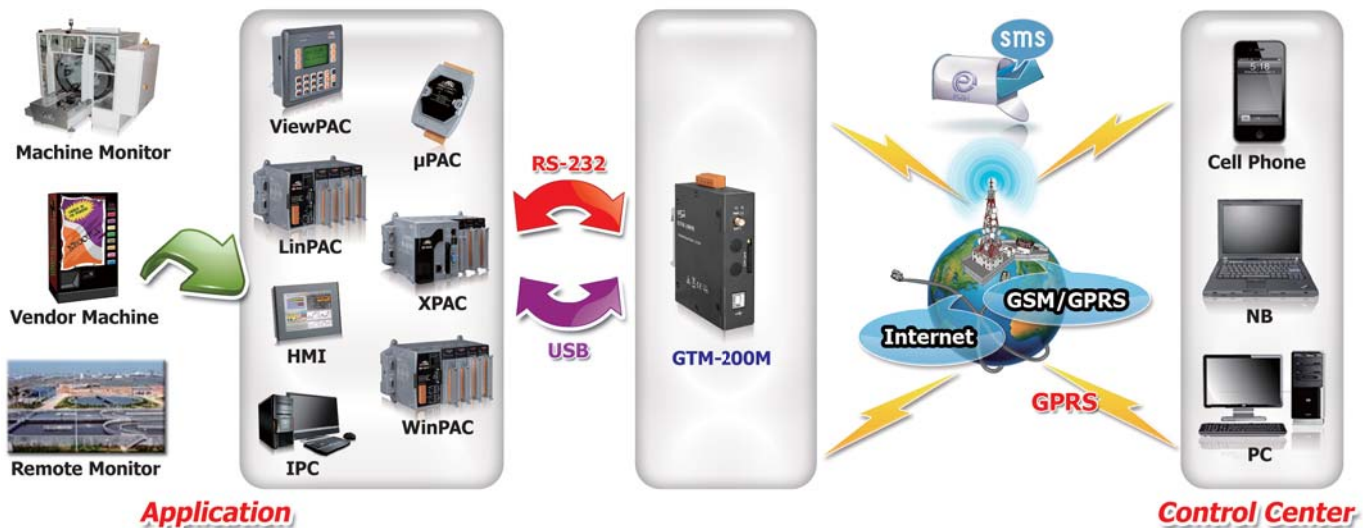

Model Name	Frequency (MHz)	Reset Input	MIC Input Audio Output	GPS	TCP/IP Stack	Baud Rate (bps)	Interface	Driver	Case
<b>GTM-203M-3GWA</b> 	2G (GSM/GPRS): 850/900/1800/1900	Yes	Yes	-	Yes	9.6K ~ 115.2K	USB2.0 RS-232	Windows XP/7/8/10, Windows Server 2012	Metal
	3G (UMTS/HSDPA/HSUPA): 2100/1900/900/850								
<b>GTM-204M-4GE</b> 	2G (GSM/GPRS): 850/900/1800/1900								
	3G (UMTS/DC-HSPA+): 850/900/2100								
	4G (FDD LTE): B1/B3/B5/B7/B8/B20								



Model Name	Frequency (MHz)	GPS Interface	Max. Download Speed	AT Command	TCP/IP Protocol
<b>I-8212W-3GWA</b> 	2G (GSM/GPRS): 850/900/1800/1900	-	115.2 Kbps	Yes	Yes
	3G (UMTS/HSDPA/HSUPA): 2100/1900/850				
<b>I-8213W-4GE</b> 	2G (GSM/GPRS): 850/900/1800/1900 3G (UMTS/DC-HSPA+): 850/900/2100 4G (FDD LTE): B1/B3/B5/B7/B8/B20	Yes	100 Mbps		



# Mini PAC with 3G/4G Communication





The G-4500 series is M2M (machine to machine) mini programmable controller with a cellular transceiver can monitor industrial equipment that sends live data to the monitoring system, providing real-time status. With optional GPS model, the G-4500 can also be a GPS tracking system. It can be used in vehicle management system or maritime system.

Model Name	OS	Interface	I/O	Frequency (MHz)	LCM (Dot)	GPS	Power Saving	Solar Charging	Case
G-4513-3GWA	MiniOS7	1 × Ethernet 1 × RS-232 1 × RS-485	3 × DO 3 × DI 8 × AI 1 × Relay	2G (GSM/GPRS): 850/900/1800/1900	-	-	YES	for 12V Lead-Acid Battery	Metal
G-4513D-3GWA					128 × 64	-			
G-4513P-3GWA				-	YES				
G-4513PD-3GWA				128 × 64	YES				

Model Name	OS	Interface	I/O	Frequency (MHz)	LCM (Dot)	GPS	Power Saving	Solar Charging	Case
G-4514-4GAU	MiniOS7	1 × Ethernet 1 × RS-232 1 × RS-485	3 × DO 3 × DI 8 × AI 1 × Relay	2G (GSM/GPRS): 850/900/1800/1900	-	-	YES	for 12V Lead-Acid Battery	Metal
G-4514D-4GAU					128 × 64	-			
G-4514P-4GAU				-	YES				
G-4514PD-4GAU				128 × 64	YES				



# M2M RTU Module

Model Name	Interface	Frequency (MHz)	I/O	Alarm	Micro SD	Battery Backup	Transparent Communication	VxComm	3G Router
<b>GT-540-3GWA</b> 	1 × RS-232 1 × RS-485	2G(GSM/GPRS): 850/900/1800/1900 3G(UMTS/HSDPA/HSUPA): 850/900/1900/2100	2 × DO 6 × DI 1 × AI	Yes (GPRS)		Yes	3G/GPRS	-	-
<b>GT-540P-3GWA</b> 	1 × RS-232 1 × RS-485 GPS								
<b>GRP-530M</b> 	1 × RS-232					Yes			
<b>GRP-540M</b> 	1 × RS-485 GPS(option)	2G(GSM/GPRS): 850/900/1800/1900 3G(UMTS/HSDPA/HSUPA): 850/900/1900/2100 4G FDD LTE: B1/B3/B5/B7/B8/B20	-	-		-	4G/3G/GPRS	Yes	Yes



## GRP-540M-4GE GRP-540M-4GC GRP-540M-4GE-WF GRP-540M-4GC-WF

### Features:

- Support 3G/4G FDD LTE/TDD LTE
- Support Ethernet, RS-232, CAN bus
- Support GPS function  
(External Antenna have to purchase separately)
- Support 3G/4G router function (NAT, DDNS...)
- Support gateway function  
(3G/4G to Ethernet, RS-232, RS-485, CAN bus)
- Support Wi-Fi interface (optional)

The GRP-540M provided by ICP DAS is a 4G gateway for Ethernet, Wi-Fi, serial port, and CAN. With GPS function, the GRP-540M can also be a GPS tracking system. It can be used in M2M application fields to transfer the remote I/O, Modbus data or video of the camera via 4G/3G/2G. Within the high performance CPU, the GRP-540M series can handle a large of data and are suit for the Harsh Industrial environment. The GRP-540M have 4G module, Ethernet interface, Wi-Fi interface, and GPS module.

### Applications:

#### Remote Video Monitor



#### Serial Port to 4G Gateway Application



# M2M RTU Center

The M2M RTU Center is a management software that has a strong core technology for handling data and lets the user save the trouble of dealing with large IO data. The RTU Center supports the G-4500 series, GT-540 and other RTU products from ICP DAS and allows users to manage these RTU devices remotely. It is not only monitor the local IO and GPS data but also IO data of Modbus RTU devices. With M2M RTU Center, users can easily establish a remote system by using EZ Data Logger or OPC Client of user's SCADA to access data.

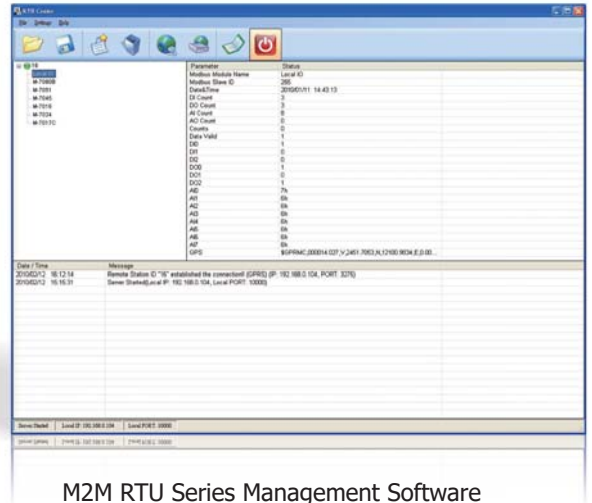

M2M RTU Series Management Software

## M2M RTU Center:

- Support up to 1024 M2M RTU devices
- Support NAPOPC.M2M server, EzDatalog and M2M API tool of ICP DAS
- Support: GT-540(P), GT-540(P)-3GWA, G-4500 serial, GRP-520
- Allow any Modbus device connecting to GPRS/Ethernet via RTU devices.
- RTU series Management tool
- Support Windows 2K/XP/7/8/10
- Easy and quick to build a Remote monitor system

## Software Architecture and Application:

When users want to use the following software or others to their system with RTU products of ICP DAS, M2M RTU Center must be executed at the same time.

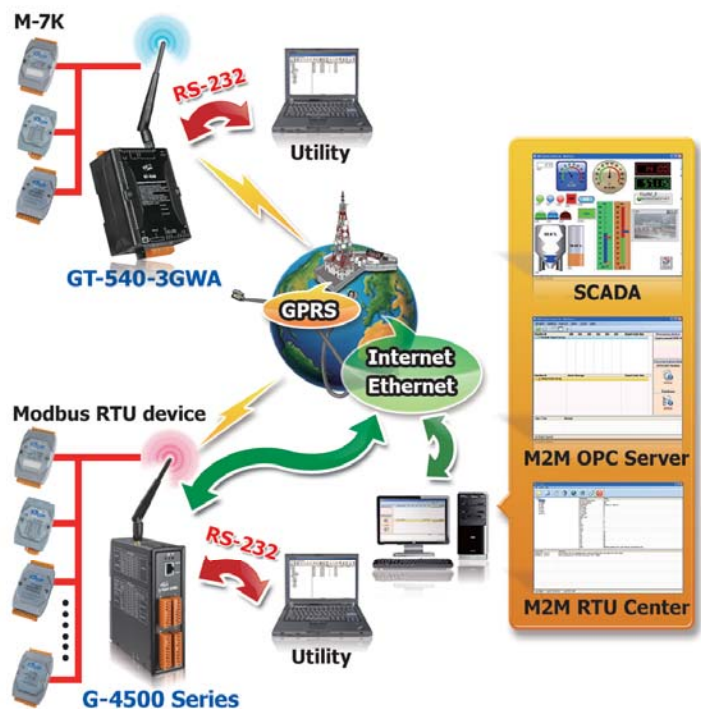
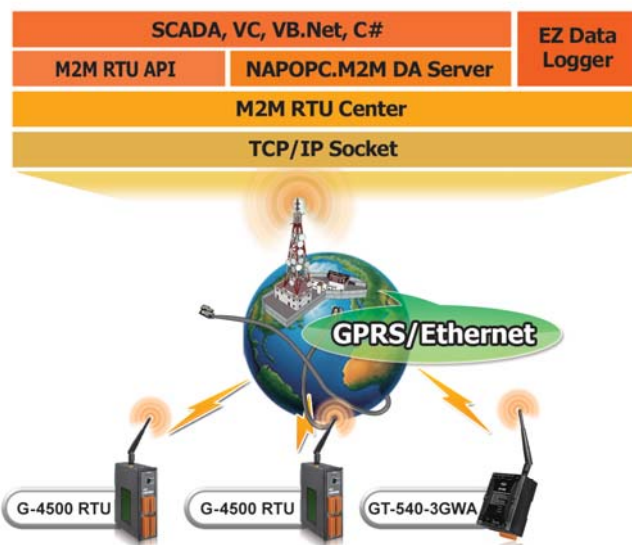



## Greenhouse Monitoring System:

Most of fruits and vegetables are sensitive to environmental factors such as temperature and humidity during their growth. Therefore, it is possible to introduce an automated greenhouse management system and monitor important environmental factors that achieve an effective improvement of agricultural products. It is the goal that farmers are pursuing.

Using the GRP-540M can solve the problem of requiring a lot of human resources in the greenhouse, automate the collection of environmental information, and integrate other greenhouse information by expanding the ZigBee module.

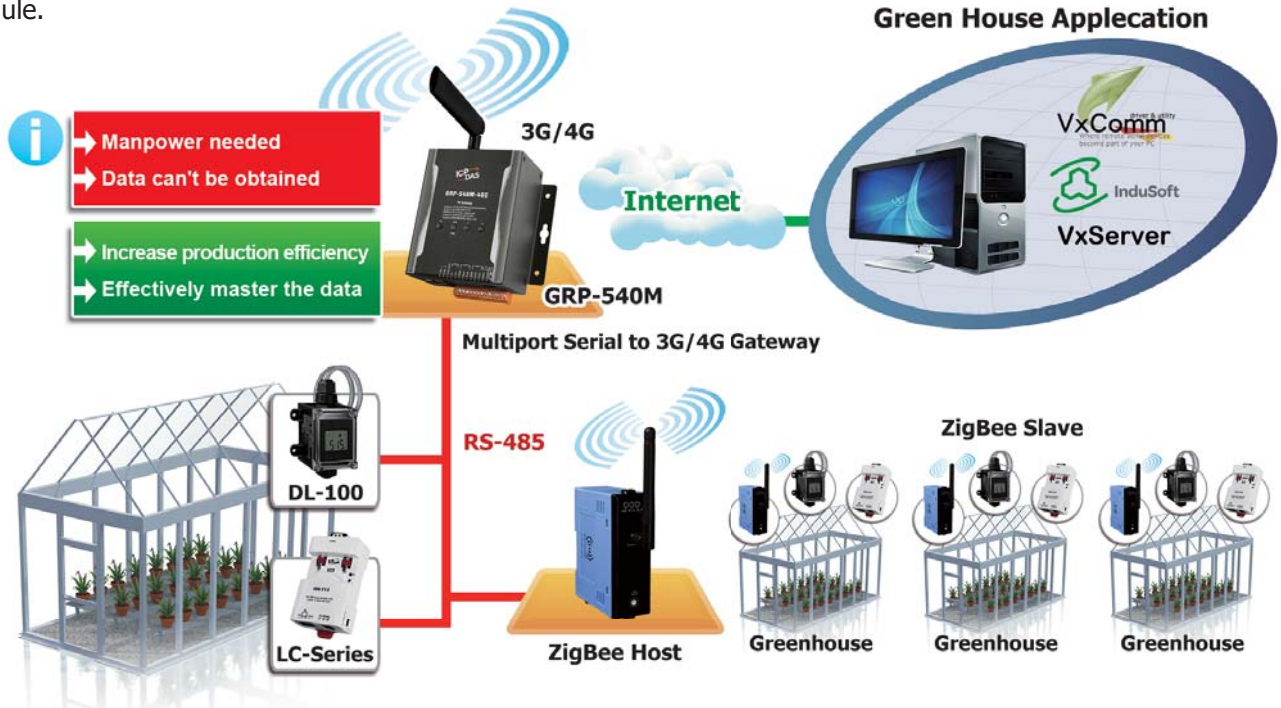

## Hydrological Monitoring Application:

The rivers in Taiwan are short and rushing. Because of these reasons, disasters are easy to occur when it comes heavy rains or winds. The relevant government departments attach great importance to the monitoring of water conditions, and set up monitoring systems in the upper, middle and lower reaches of the river to get the information of the water situation. These areas are not only difficult to set up on the Internet, but even the power of Taipower is difficult to reach. Therefore, the G-4514 with built-in solar charging is the most suitable to set up the monitoring system. When there is no sunlight in the rain, it can only operate on battery power for 3 or 4 weeks, so that the water monitoring is not interrupted.

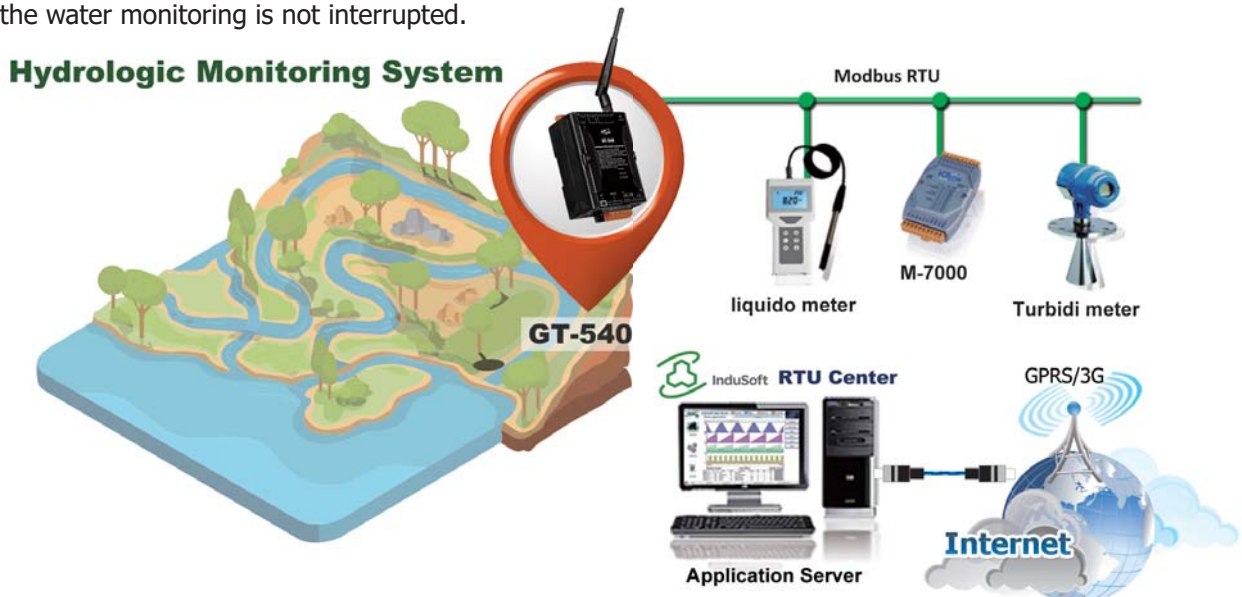

# 5. NB-IoT Solution

NarrowBand-Internet of Things (NB-IoT) is a 3GPP standards-based Low Power Wide Area Network (LPWAN) technology which can exist together with current 2G, 3G, and 4G mobile network. It only with an occupied bandwidth of 180kHz. Compared with LoRa, SigFox and other non-licensed band technologies of the LPWAN, NB-IoT operates in licensed spectrum and supported by the most mobile network operators, it is more advantageous in the future development.

### Features:

- Extended coverage
- Low power consumption
- Low component cost
- Low occupied bandwidth
- Massive connections

## Low Power Wide Area Network (LPWAN)

	Organization	Frequency Band	Transmission Distance	Baud Rate	Connection	Benefit
<b>LoRa</b>	LoRa Alliance	Sub-GHz (Unlicensed)	Urban: 3 ~ 5 km Suburban: 15 km	300 bps ~ 50 kbps	250k/cell	1. Mature industry chain. 2. Operate in unlicensed spectrum is no communication fee.
<b>NB-IoT</b>	3GPP	GSM/LTE Band (Licensed)	Urban: 3 ~ 5 km Suburban: 15 km	<250 kbps	100k/cell	1. Don't have to reconstruct the network. 2. High security. 3. Supported by the most mobile network operators.
<b>SigFox</b>	SigFox Company	Sub-GHz (Unlicensed)	Urban: 10 km Suburban: 50 km	100 bps	1000k/cell	1. Mature technology 2. Operating in unlicensed spectrum is no communication fee.

### Applications:



### Inverter Monitor Application :

Nowadays, renewable energy is often discussed, among which solar energy is best known. Solar energy monitoring mainly uses 3G/4G networks to transmit data. However, the amount of returned data is just a little, user still has to pay the same monthly fee. Therefore, NB-IoT's advantage of low monthly rental fee will effectively reduce the maintenance cost of the manufacturer.

### Features:

- Remotely monitoring solar power generation and the environmental condition of the site.
- Using low-power and low monthly fee network to reduce operating costs.
- Analyze the historical data of solar power generation and adjust the power generation strategy in a timely manner.

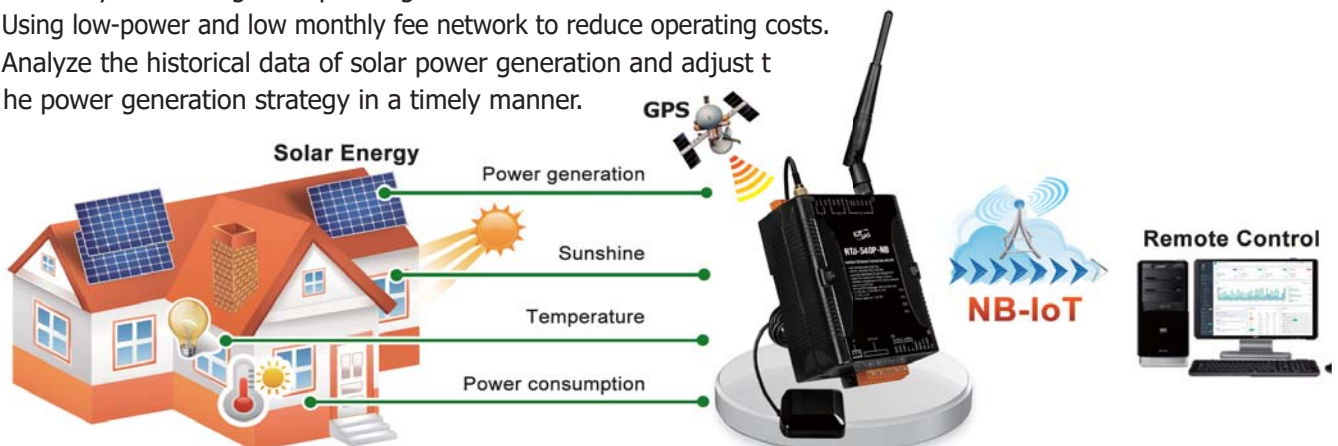

## Rainwater Retention System:

Because the shortage of domestic water resources and the deterioration of the water environment, in addition to water conservation, the recycling and reuse of water has made considerable contributions to environmental protection and ecological conservation. Therefore, ICP DAS utilizes the most advanced technology - NB-IoT.

Using the low-power wireless communication network to build a rainwater storage system that monitors tap water and rainwater usage, learns the rainwater replacement rate, and monitors the remaining amount of rainwater and water quality information, user can use website and APP to get the efficiency of water recycling easily. NB-IoT communication technology is one of the Internet of Things which has power saving mechanism, and advantages such as low cost (low monthly fee), high reliability, extended coverage, that will greatly enhance the effectiveness of the system.

### Features:

- Include sensing objects such as water level, turbidity, outdoor temperature and rain gauge.
- Transfer data by NB-IoT to save cost.
- Classify data in the cloud platform, using website and APP to monitor in any time.
- Users can use the data for purposes such as massive data analysis or system operation management.

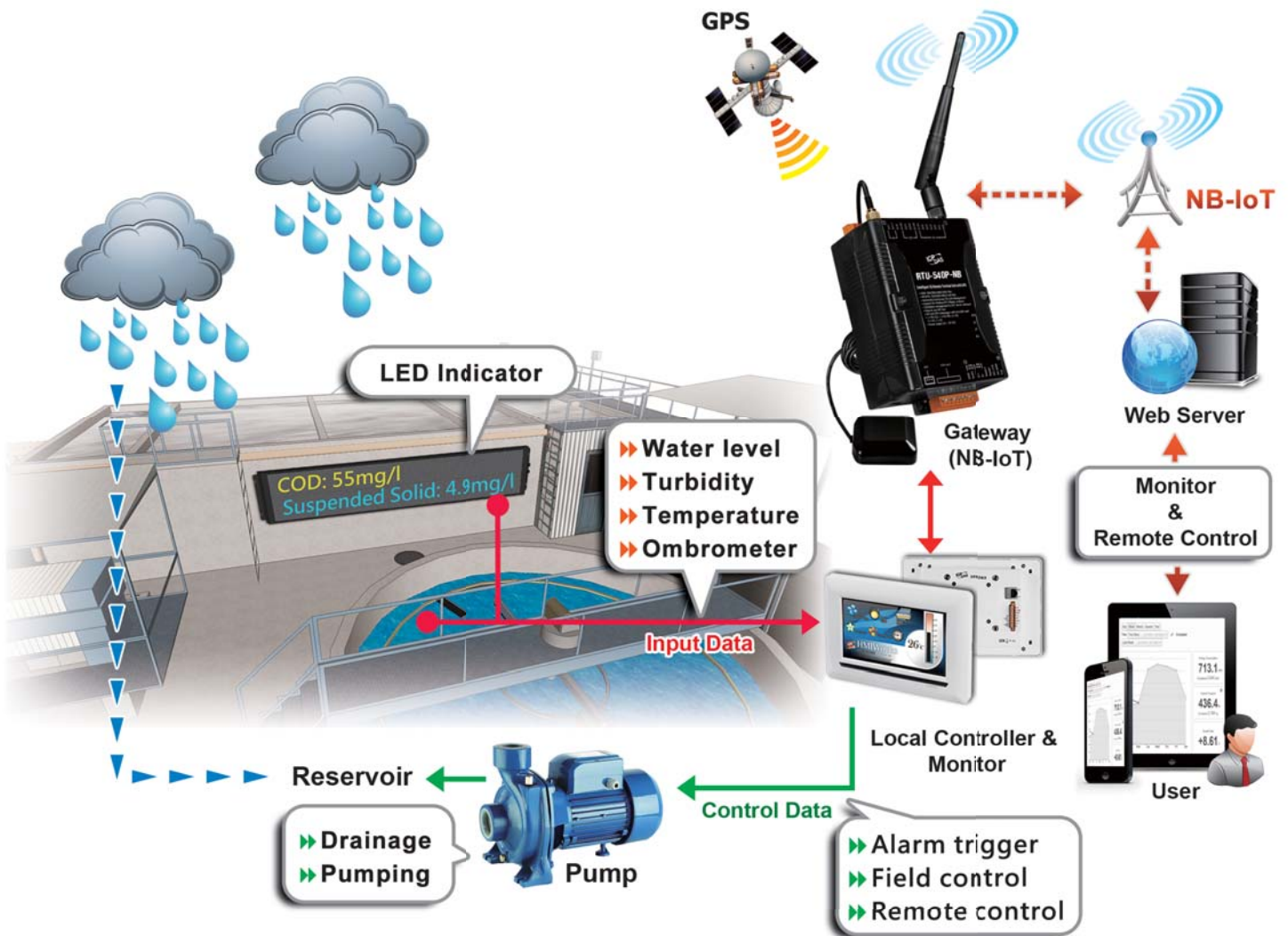

### Smart AGRI Application:

Information such as soil temperature and humidity, pH, sunshine and air temperature and humidity are very beneficial for agricultural cultivation. Farmers don't have to patrol the farmland frequently, but rely on this information doing some proper processing and management. In addition, the power-saving technology of NB-IoT and the solar energy are helpful for monitoring system, it can maintain normal operation for a long time without external power supply, greatly reducing its cost.

### Features:

- Solar energy and battery will charge and discharge to be a self-contained system.
- Monitor plant growth environment by light, temperature, humidity, and air quality.
- Remotely monitor about soil pH, temperature and humidity, and allow farmers to respond any conditions immediately.



# NB-DA Server IoT Data collection and monitoring software

The screenshot displays the NB-DA Server configuration interface. It includes three main configuration panels: System Config, Data Base Config, and MQTT Config. Below these panels is a table showing the status of three servers.

**System Config:**

- Total Servers: 3
- Buttons: Add Server, Delete Server, Start Server, Stop Server, Start All Servers, Stop All Servers
- Station ID: 0
- UDP Server Port: 5394
- Modbus Server Port: 502
- Session alive time (s): 120
- Save Log Info:

**Data Base Config:**

- Enable:
- SQL Type: mysql
- SQL IP: 127.0.0.1
- SQL Data Base: grp-540m-nb
- SQL User Name: nbiot
- SQL Password: \*\*\*\*\*
- SQL Size Alarm (MB): 0
- SQL Size Limit (MB): 0

**MQTT Config:**

- Enable:
- MQTT Broker: iot.eclipse.org
- MQTT Port: 1883
- MQTT Subscribe: .cloud.ICPDAS
- MQTT Publish: .cloud.ICPDAS
- MQTT User Name:
- MQTT Password:

Station	UDP Port	Modbus Port	MQTT	Data Base	Status	Sessions	Log View
0	5394	502	Disable	Enable	Online	4	Open
2	5396	504	Disable	Enable	Online	0	Open
99	5493	601	Enable	Enable	Online	1	Open

## Features:

- Support UDP Server to receive information about SMS4 encryption protocols.
- Support MQTT publishing and subscription, provide data access and remote control functions.
- Support MySQL/MariaDB database, provide data overwriting function
- Support Modbus Server, provide Modbus TCP protocol to access data and remote control.
- Support RAM Disk, user can use CSV file s to access data directly.
- Support Windows 7/10.

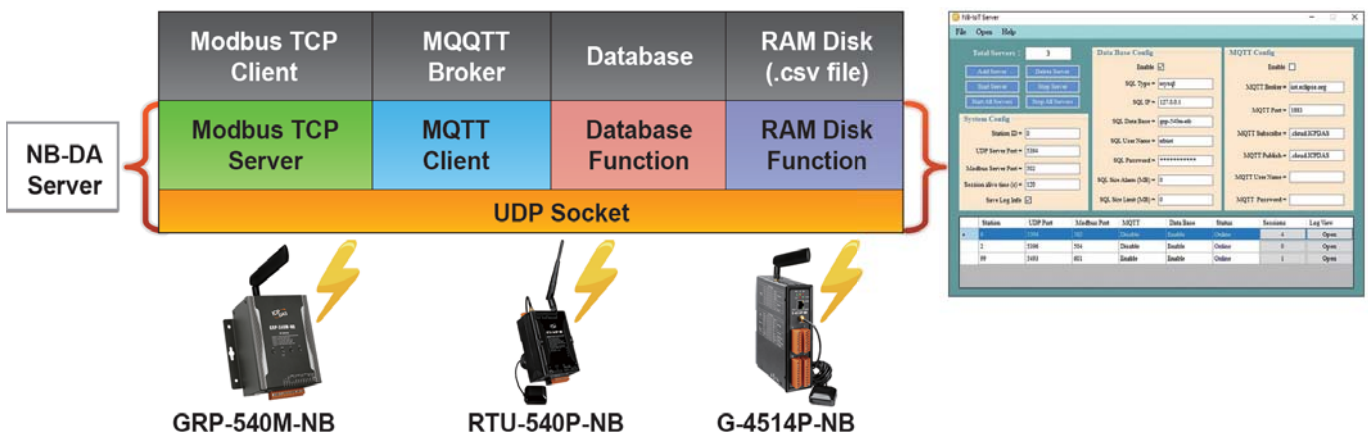

NB-DA Server is a software for data collection and monitoring. It supports setting up multiple stations for different projects, each station can connect 2000 sessions, and can display the log messages of each station and the survival status of all sessions (including information such as signal, power, etc.) . The southbound interface has UDP Server for communication with devices such as RTU-540P-NB and GRP-540M-NB, while the northbound interface provides MQTT, Modbus Server and database for users to access data. In addition, users can also remotely control Modbus I/O requirements by sending simple MQTT or Modbus TCP commands.

# NB-IoT Gateway



**GRP-540M-NB**

**Features:**

- Frequency Band: B1 ,B3 ,B5 ,B8 ,B20 ,B28
- NB-IoT automatic and reconnection mechanism
- Support UDP (SMS4 encryption), MQTT protocol
- Ethernet and RS-232/485 expand I/O with Modbus protocol
- Maximum data collection: 64x AI, 64x AO, 64x DI, 64x DO
- 10/100 Base-TX Network controller
- GPS: 32 Channels
- Build-in 4G Micro SD card, can record Device Info, I/O and GPS data
- High reliability

GRP-540M-NB provided by ICP DAS is a gateway for Ethernet, serial port to NB-IoT. It can be used in M2M application fields to transfer Modbus I/O data to server via NB-IoT. With high-performance CPU, GRP-540M-NB can handle large amounts of data and operate in harsh industrial environments. When connected to the NB-DA Server, users can also remotely control all Modbus devices connected to GRP-540M-NB.



Module Name		GRP-540M-NB	
<b>Software</b>		<b>Comm. Interface</b>	
Gateway Function	Ethernet and Serial port (RS-232 x1, RS-485 x1) to NB-IoT	Ethernet	RJ-45, 10/100 Base-TX (Auto-negotiating, Auto MDI/MDI-X, LED indicators)
Embedded service	Web Server, NB-IoT Gateway	COM1	RS-232 (RxD, TxD and GND); Non-isolated(Console, Debug)
<b>System</b>		COM2	RS-232 (RxD, TxD and GND); Non-isolated
CPU	ARM CPU	COM3	RS-485 (D2+, D2-); 3000 VDC isolated
EEPROM	16 KB (Data Retention: 40 years; 1,000,000 erase/write cycles)	CAN	CAN Bus (CAN_H, CAN_L)
Expansion Flash Memory	SD Card (Max. 32GB SDHC)	<b>Mechanism</b>	
RTC (Real Time Clock)	Provide seconds, minutes, hours, day of week/month, month and year	Casing	Matel
64-bit Hardware Serial Number	Yes	Dimensions (W × L × H)	117 mm × 126 mm × 58 mm
Watchdog Timer	Yes	Installation	DIN-Rail / Screw
LED Indicator	4 LEDs (RUN/PWR, NB-IoT, L1, L2)	<b>Power</b>	
Rotary Switch	Yes (0~9)	Protection	Power reverse polarity protection
<b>NB-IoT System</b>		Frame Ground Protection	ESD, Surge, EFT, Hi-Pot
Frequency Band	LTE NB-IoT B1, B3, B5, B8, B20, B28	Required Supply Voltage	+10 VDC ~ +48 VDC
<b>GPS System (option)</b>		Power Consumption	4.8 W ( 200 mA @ 24 VDC)
Support Channels	32		
Protocol Support	NMEA 0183		

## Applications:

### ■ NB-IoT Gateway



### ■ Data Collection and Remote Control (with NB-DA Server)



### ■ Data Collection and Remote Control (with MQTT Broker)

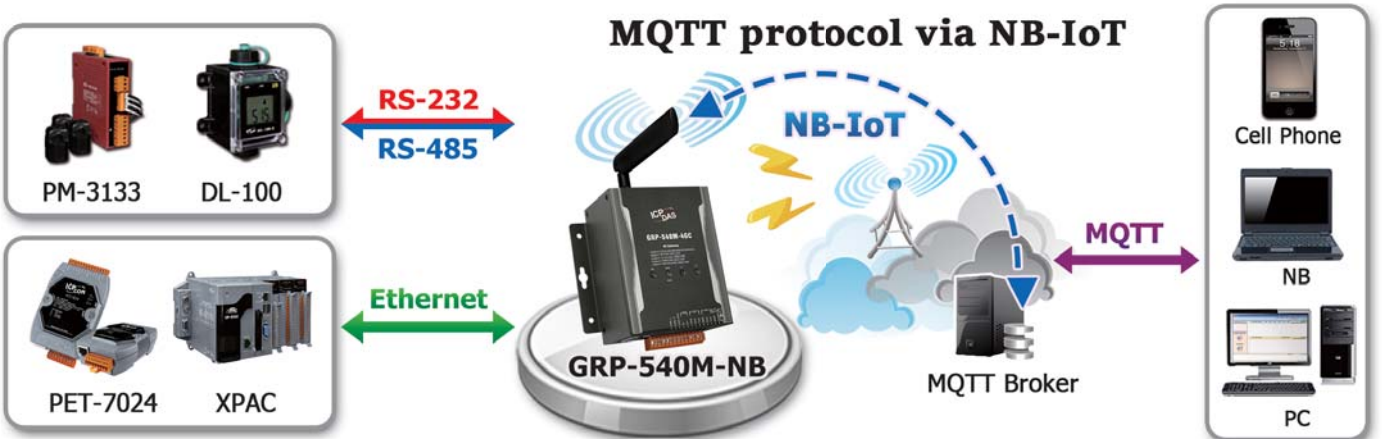

# Intelligent NB-IoT Remote Terminal Unit with GPS



**RTU-540P-NB**

**Features:**

- Frequency Band: B1 ,B3 ,B5 ,B8 ,B20 ,B28
- NB-IoT automatic and reconnection mechanism
- Support UDP (SMS4 encryption), MQTT protocol.
- Build-in I/O: 1x AI, 6x DI, 2x DO
- RS-232/485 expand I/O with Modbus protocol
- Maximum data collection: 32x AI, 32x AO, 32x DI, 32x DO
- Build-in 4G Micro SD card, can record I/O and GPS data
- GPS: 32 Channels
- Support 3.7V Li-ion Battery backup

RTU-540P-NB is an intelligent Active GPRS Remote Terminal Unit with GPS. It can be used in M2M applications, and the data of I/O, GPS and Modbus devices of RTU-540P-NB will be transmitted through LTE NB-IoT by predefined cycle time or triggered by DI/AI. It also has the function of I/O datalogger, which can store I/O and GPS data in SD card. In addition, the simple logic control of the local I/O allows the RTU-540P-NB to perform control on the spot.

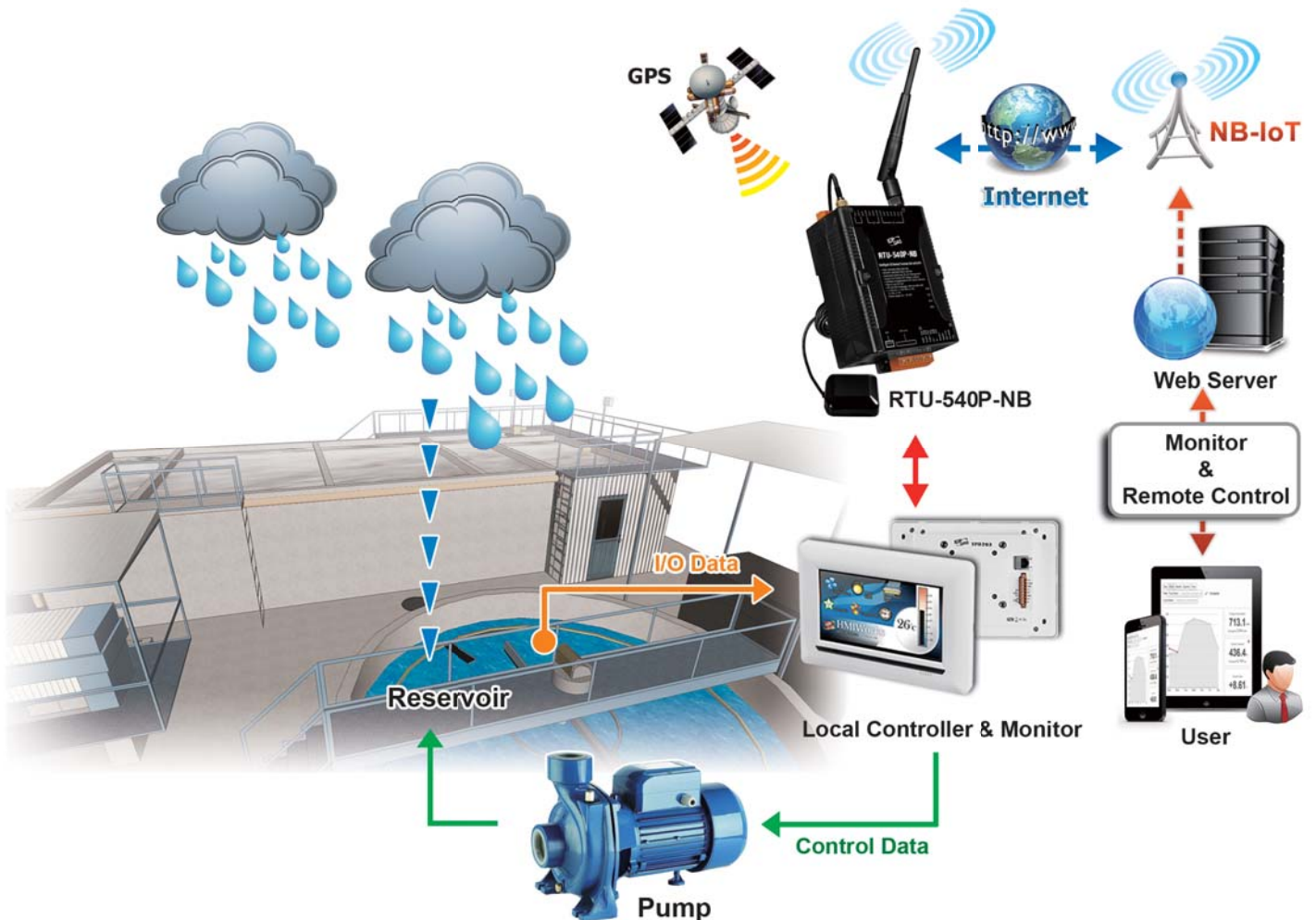



# Power Saving NB-IoT PAC with Solar charger



**G-4514P-NB**

## Features:

- Frequency Band: B1 ,B3 ,B5 ,B8 ,B20 ,B28
- Embedded MiniOS7, anti-virus
- NB-IoT automatic and reconnection mechanism
- Support UDP (SMS4 encryption), MQTT protocol
- Provide Standard AT Commands
- 10/100 Base-TX compatible Ethernet controller
- I/O: 3 DI, 3 DO, 8 AI, 1 relay DO
- Build-in 4G Micro SD card, can record I/O and GPS data
- GPS: 32 Channels
- Built-in RTC, NVRAM, EEPROM
- High reliability in harsh environments
- Solar / lead acid battery charger
- Support auto sleep mode, greatly reducing power consumption

G-4514P-NB is a power saving NB-IoT PAC, built-in solar / lead acid battery charger. G-4514P-NB is ideal for applications such as hydrological monitoring, earth-rock flow monitoring, or application which is inconvenient power need to use solar energy. I/O data logger can store I/O and GPS data in the SD card. If combined with its GPS function, it can be applied to the field of vehicle and river boat monitoring.





## 6. GPS Products

GPS (Global Positioning System) is widely used for driving navigation, geographic monitoring, fleet management and cargo tracking, etc. We also can use GPS for industrial application according to its longitude and latitude value and UTC time. ICP DAS provides various modules for different applications. Some are pure GPS data receivers and some add DO channels. Some even can generate a UTC synchronized 1 PPS (Pulse Per Second).

Model Name	GPS Channels	SBAS	GPS Output Interface	3G/4G	Digital Output	Protocol/Interface	Description
I-87211W	32	WAAS, EGNOS, MSAS	RS-232 (NMEA)	-	2	DCON/*Note1	GPS Receiver and 2 DO Module
I-8213W-3GWA			*Note2	Yes (TCP/IP protocol) *Note3	-	-	GPS Receiver and GPRS Controller Module
I-8213W-4G series			USB *Note4	Yes (TCP/IP protocol) *Note4	-	-	GPS Receiver and 3G/4G Controller Module
GPS-721			RS-232 (NMEA)	-	1	DCON/RS-485	GPS Receiver and 1 DO Module
GPS-721U-MRTU			-	1	DCON, Modbus RTU/ RS-485		

**[\*Note1]** The support list of MCU (Main Control Unit) and I/O expansion unit are: XPAC, WinPAC, LinPAC, iPAC, ViewPAC, U-87P1/2/4/8, USB-87P1/2/4/8, I-8000, I-8KE4/8, I-8KE4/8-MTCP, I-87K4/5/8/9

**[\*Note2]** Gets GPS Information from Parallel bus (API). The support list of MCU: XPAC, WinPAC, LinPAC, iPAC, ViewPAC, etc.

**[\*Note3]** Gets GSM/GPRS Information from Parallel bus (API). This GPRS/GSM module is integrated with the TCP/IP protocol, Extended TCP/IP AT commands. The support list of MCU : XPAC, WinPAC, LinPAC, iPAC, ViewPAC, etc.

**[\*Note4]** Gets GPS or 3G/4G Information from USB (API). This 3G/4G module is integrated with the TCP/IP protocol Extended TCP/IP AT commands. The support list of MCU:XPAC, WinPAC, LinPAC, etc.

## 7. Bluetooth LE Converters

The ICP DAS provides two kinds of Bluetooth low energy (LE) converters. One is the RS-232/RS-422/RS-485 to Bluetooth LE converter. The other is the USB to Bluetooth LE converter. The ICP DAS Bluetooth LE converter can combine into some existing systems that use RS-232, RS-422 or RS-485 network, and it can use smartphone, tablet or notebook as receiver. It will greatly to improve ease of use.



### RS-232/RS-422/RS-485 to Bluetooth LE Converter

Model Name	Bluetooth LE Standard	Interface	Data Rate	Transmit Range
tBLE-720	Bluetooth 4.0	RS-232/RS-422/RS-485	85 kbps	20 m (LOS)

### USB to Bluetooth LE Converter

Model Name	Bluetooth LE Standard	Interface	Data Rate	Transmit Range
BLE-USB	Bluetooth 4.0	USB	85 kbps	20 m (LOS)

# 8. ZigBee Products



## Features:

- ISM 2.4 GHz Operating Frequency and Fully Compliant with 2.4 G IEEE 802.15.4 / ZigBee PRO (2007)
- Support 3 Topologies Defined in the ZigBee Standard: Mesh, Star and Cluster Tree
- Support the 128-bit AES (Advanced Encryption Standard) Encryption
- GUI Configuration Software (Windows Version)
- ZigBee Node Supports Active Routing
- Supports Topology Utility for Network Monitoring and Improvement
- Wireless Transmission Range up to 700 m (Default)
- Provide Signal Strength LED Indicator
- Wide Operating Temperature (-25 ~ 75°C)

ZigBee is a specification based on the IEEE 802.15.4 standard for wireless personal area networks (WPANs). ZigBee operates in the ISM radio bands, and it defines a general-purpose, inexpensive, self-organizing, mesh network for industrial control, medical data collection, smoke and intruder warning, building automation and home automation, etc.

## ZigBee Converter:

Every network must have one host (coordinator) device for initializing, maintaining, and controlling the network; one or more slave devices (full function devices) are responsible for routing messages.

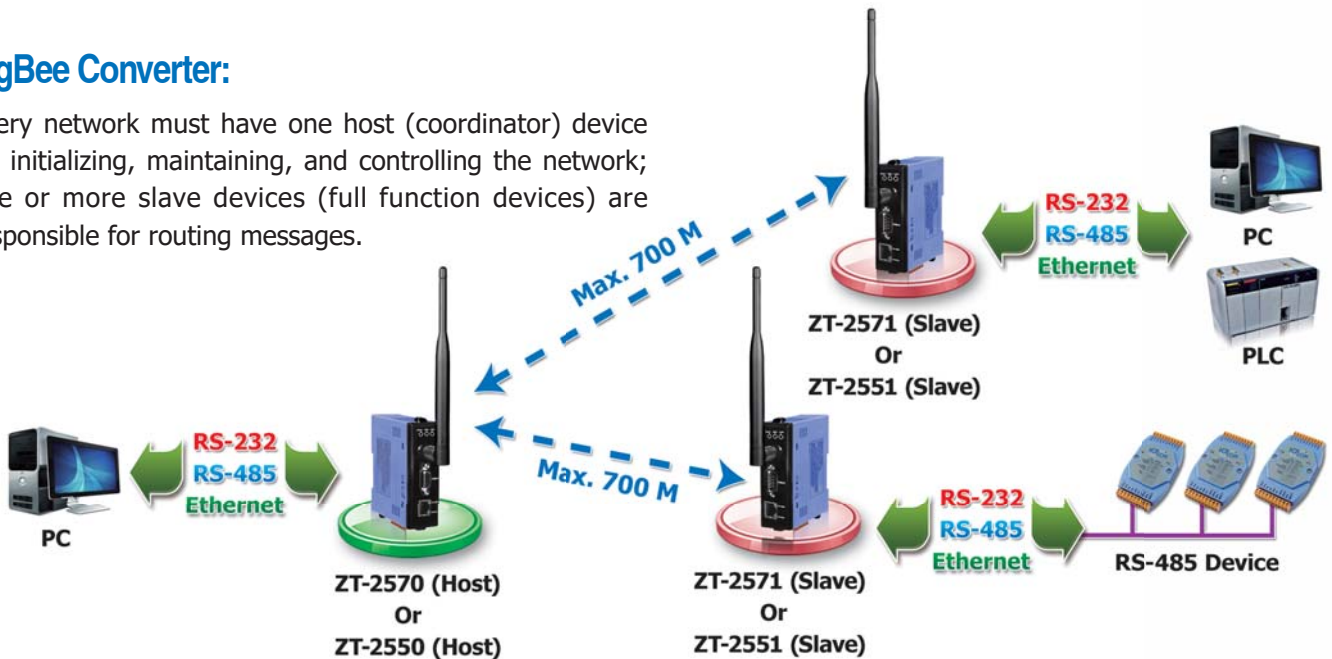

Model Name	Interface	Module Type	Transmit Power	Antenna	Distance (LOS)
ZT-2550	1 × RS-232 · 1 × RS-485	Host (Coordinator)	11 dBm	2.4 GHz, 5 dBi Omni-Directional antenna	700 m
ZT-2551	1 × RS-232 · 1 × RS-485	Slave (Router)	11 dBm	2.4 GHz, 5 dBi Omni-Directional antenna	700 m
ZT-2570	1 × RS-232 · 1 × RS-485 1 × Ethernet	Host (Coordinator)	11 dBm	2.4 GHz, 5 dBi Omni-Directional antenna	700 m
ZT-2571	1 × RS-232 · 1 × RS-485 1 × Ethernet	Slave (Router)	11 dBm	2.4 GHz, 5 dBi Omni-Directional antenna	700 m
ZT-USBC	1 × USB	Full Function (Coordinator/Router)	3 dBm	2.4 GHz, PCBantenna	60 m

### ZigBee Repeater:

The ZT-2510 is a ZigBee repeater to extend the distance of ZigBee network or avoid an obstacle that may be located between two wireless devices.

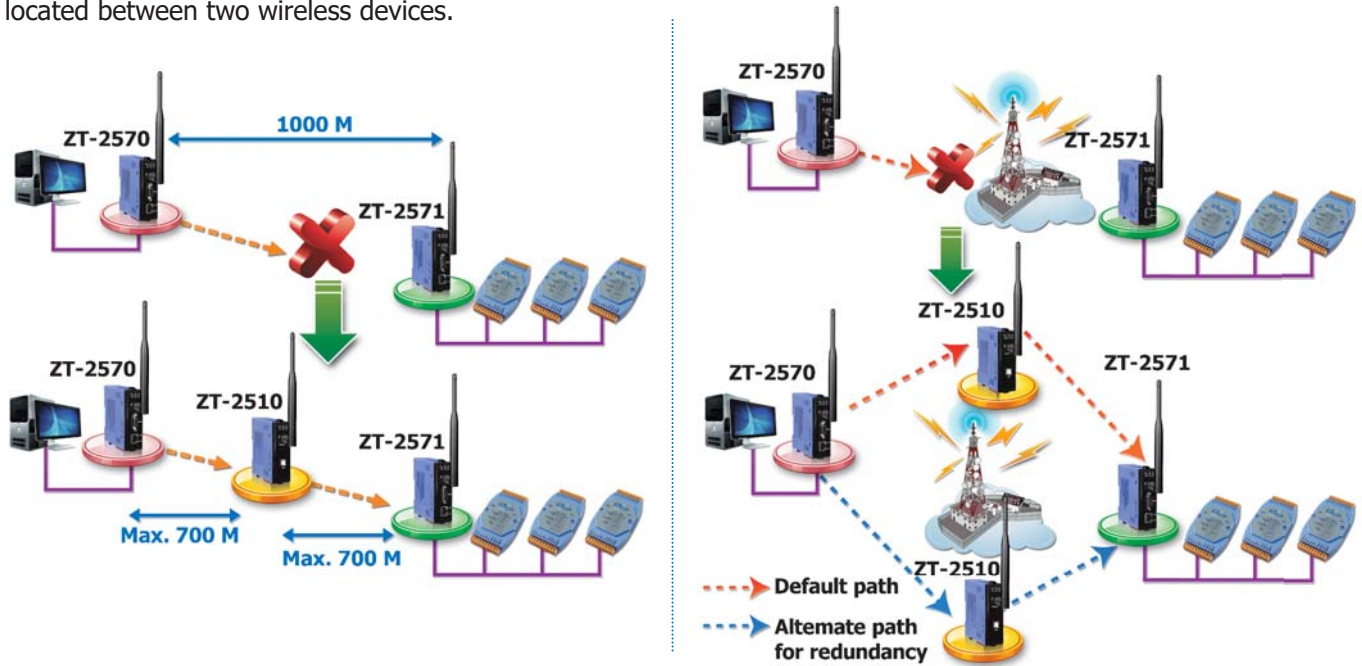

Model Name	Interface	Module Type	Transmit Power	Antenna	Distance (LOS)
ZT-2510	ZigBee	Slave (Router)	11 dBm	2.4 GHz, 5 dBi Omni-Directional antenna	700 m

### ZigBee Bridge:

The ZT-2530M is a ZigBee bridge operating as a bridge between two ZigBee networks. It is full hardware configuration, used to communicate indoor and outdoor units or divide complex network to enhance efficiency.

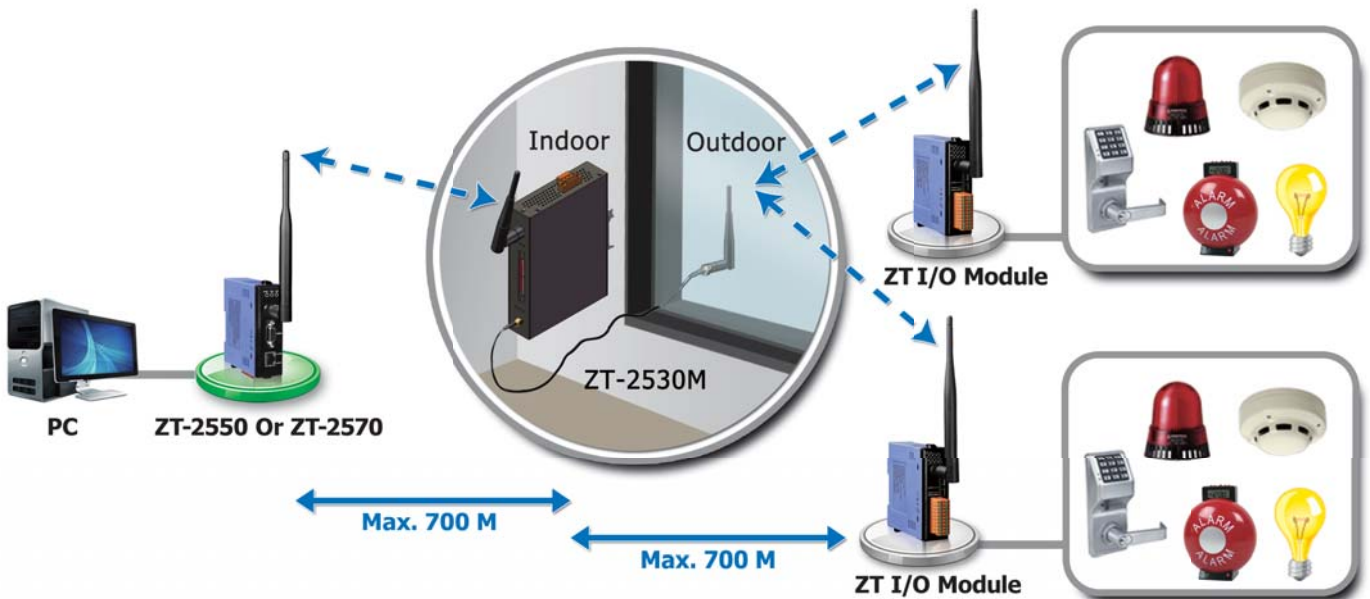

Model Name	Interface	Module Type	Transmit Power	Antenna	Distance (LOS)
ZT-2530M	ZigBee	Slave (Router) + Host (Coordinator)	11 dBm	2.4 GHz, 5 dBi Omni-Directional antenna	700 m

## ZigBee I/O Group Module (Full Function):



The ZT-20xx-IOG is a self-controller that no programming and no dealing with the wireless communication interference needs, but can quickly establish, monitor and manage the I/O pair-connection with the decentralized DIO channels. It suits the wireless I/O Pair-connection applications for the environment of needing many I/O points, large communication range and not easy wiring.

The ZT-20xx-IOG provides Ethernet, RS-232 or RS-485 communication interface. It is a data concentrator that no programming and no dealing with the wireless communication interference needs, but can quickly establish, monitor and manage the I/O pair-connection with the decentralized DIO channels. It suits the multi-host monitoring and I/O Pair-connection wireless applications for the environment of needing many I/O points, large communication range and not easy wiring.

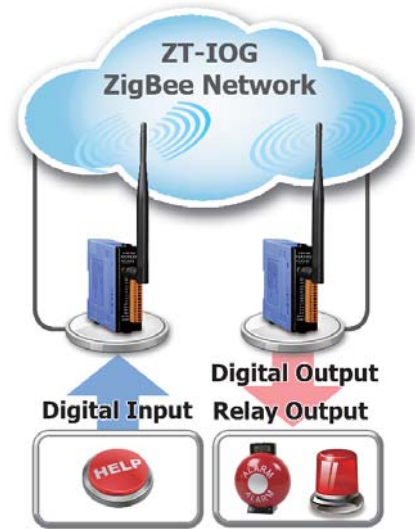

Model Name	Channel	Type	Channel	Type
ZT-2043-IOG	DO: 14	Open Collector (700mA, Sink)		
ZT-2053-IOG	DI: 14	Dry/Wet (Sink/Source)		
ZT-2055-IOG	DI: 8	Dry/Wet (Sink/Source)	DO: 8	Open Collector(650 mA, Sink)
ZT-2060-IOG	DI: 6	Wet (Sink/Source)	DO: 4	Power Relay (5 A @ 250 VAC/30 VDC)

## ZigBee I/O Module (Router):



Model Name	Channel	Type	Channel	Type
ZT-2005-C8	AI: 8	10 K Thermistor (Measuring Temperature Range: -40°C ~ 105°C)		
ZT-2015	AI: 6	Pt100, Pt1000, Ni120, Cu100, Cu1000		
ZT-2017	AI: 8	±10 V, ±5 V, ±1V, ±500 mV, ±150 mV or -20 mA ~ +20 mA (Requires External 125 Ω Resistor)		
ZT-2017C	AI: 8	20 mA ~ +20 mA, 0 mA ~ +20 mA or +4 mA ~ +20 mA		
ZT-2018	AI: 8	±15 mV, ±50 mV, ±100 mV, ±500 mV, ±1V, ±2.5V, ±20 mA, 0 ~ 20 mA or 4 ~ 20 mA Thermocouple (J, K, T, E, R, S, B, N, C, L, M, LDIN43710)(Requires Optional External 125 Ω Resistor for current input)		
ZT-2024	AO: 4	0 ~ +10 VDC, -10 VDC ~ +10 VDC, 0 ~ +5 VDC, -5 VDC ~ +5 VDC, 0 ~ +20 mA, +4 mA ~ +20 mA		
ZT-2026	AI: 4	±10 V, ±5 V, ±1 V, ±500 mV, ±150 mV or -20 mA ~ +20 mA	AO: 2	±10 VDC, ±5 VDC, 0 ~ 10 VDC or 0 ~ 5 VDC
	DI: 2	Wet (Sink)	DO: 2	Open Collector (700 mA, Sink)
ZT-2042	DO: 8	4*PhotoMOS Relay (1 A, Sink/Source) / 4*Open Collector (700 mA, Sink)		
ZT-2043	DO: 14	Open Collector (700mA, Sink)		
ZT-2052	DI: 8	Wet (Sink/Source)		
ZT-2053	DI: 14	Dry/Wet (Sink/Source)		
ZT-2055	DI: 8	Dry/Wet (Sink/Source)	DO: 8	Open Collector (650 mA, Sink)
ZT-2060	DI: 6	Wet (Sink/Source)	DO: 4	Power Relay (5 A @ 250 VAC/30 VDC)

## ZigBee Accessories: External Antenna/Cable:



Optional Accessories	Description and Website
<b>External Antenna</b>	2.4 GHz External Antenna, RP-SMA Male (Plug)
External Antenna: <a href="http://www.icpdas.com/root/product/solutions/industrial_wireless_communication/wlan_products/external_antenna.html">http://www.icpdas.com/root/product/solutions/industrial_wireless_communication/wlan_products/external_antenna.html</a>	
<b>External Cable</b>	3500x-1, RG58A/U x-meter long RP-SMA male to RP-SMA Female
Extension Cable: <a href="http://www.icpdas.com/root/product/solutions/accessories/cable/cable_selection.html">http://www.icpdas.com/root/product/solutions/accessories/cable/cable_selection.html</a>	

# 9. Infrared Wireless Modules

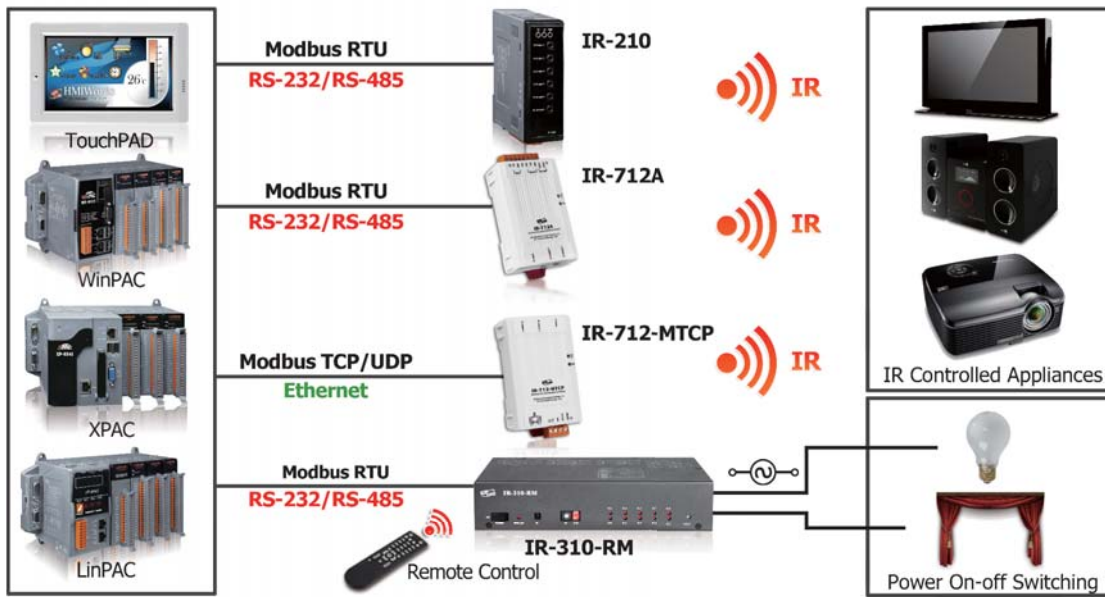

IR (infrared) technology is now used for controlling home devices including television, air conditioner and etc. ICP DAS has developed various IR products to apply in home automation. These IR products can help users to control and integrate these IR devices into a control system. Therefore, by integrating the PAC and others series of ICP DAS, users can easily to establish the home automation system. IR Series includes "IR learning remote modules" and "IR controlled power relay module". The former are used to collect and transmit a variety of devices infrared remote commands, while the latter is a strong relay module with the electric remote control function.

## IR Smart Home Application

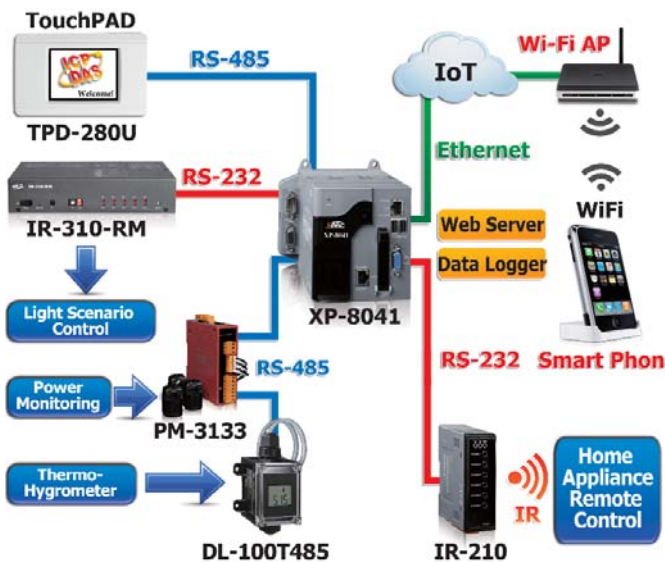

## IR + Wi-Fi Wireless Control Application

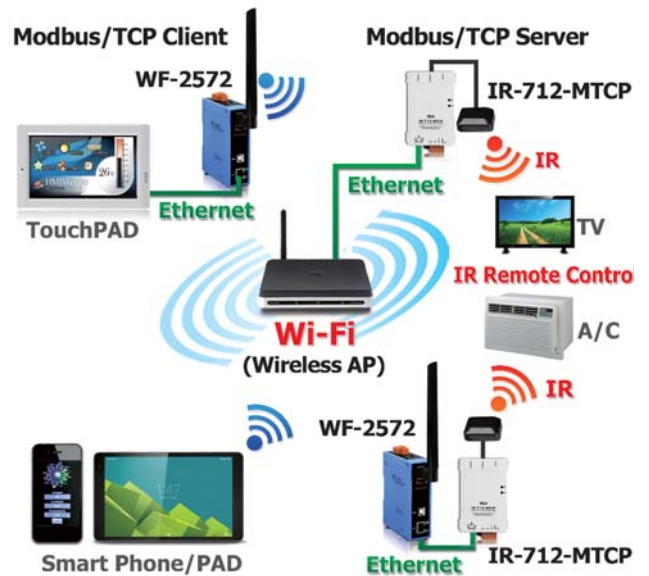

## Selection Guide:

Type	IR Learning Remote Modules			IR Controlled Power Relay Module
	IR-210	IR-712A	IR-712-MTCP	IR-310-RM
Output	IR Output × 6	IR Output × 2	IR Output × 2 Modbus TCP	Relay Output × 10
Included Cable	Two CA-IR-SH2251 (-5 model with -5 model cable) and one CA-0910		Two CA-IR-SH2251 (-5 model with -5 model cable)	One CA-IR-SH2251-5, one CA-IR-001, one CA-0910 and one remote control L108E

# Universal IR Learning Remote Module



## Features:

- IR Output: channels for remote controlling multiple devices
- IR Input: can learn and store IR Commands
- Supports 6 learning IR carrier frequencies
- Provide LEDs: Transmitting / Learning / Power
- Can save IR commands to files and show waveforms

ICP DAS universal IR learning remote module can learn IR remote commands of diverse electronic devices, and store the commands in the module or saved to a file. The RS-232/485/Ethernet interfaces provide flexible expansion and control the module. The software utility provides users with easy configuration, learning, test and storage of IR commands. It is well-designed for smart home and building automation.

## IR Utility: configuration, IR learning and waveform display

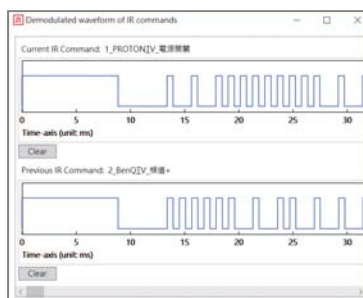
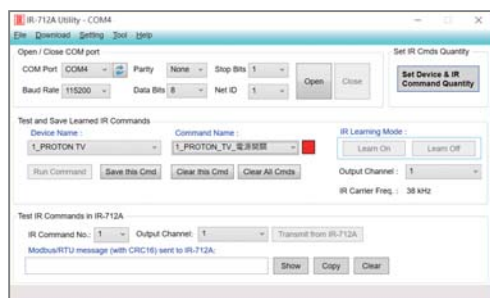

**ICP DAS PAC**

**WinCE PAC**

- XPAC**
- WinPAC**
- ViewPAC**

**Linux PAC**

**MiniOS PAC**

- LinPAC**
- µPAC**
- iPAC**
- ViewPAC**

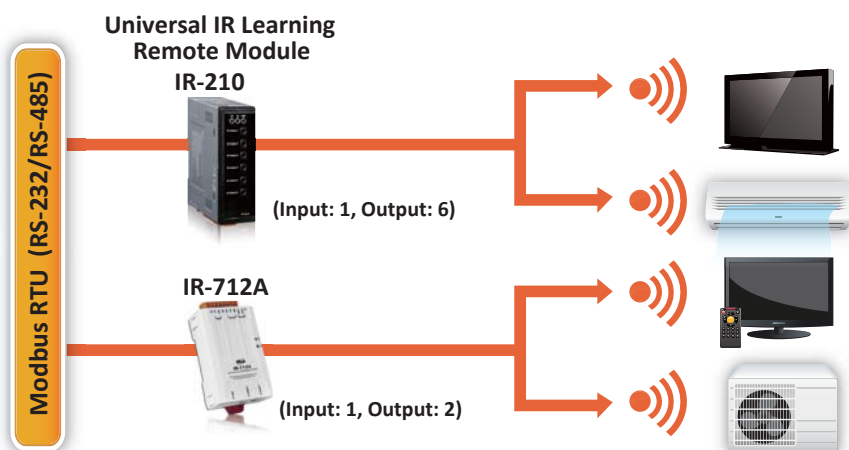

Model Name	IR-210	IR-712A	IR-712-MTCP
IR Output Channels	6		2
IR Commands Storage	224	224	512
Support IR Carrier Freq.	33、36、37、38、40、56 kHz		
Serial Comm. Interface	RS-232 × 1 and RS-485 × 1		Ethernet × 1
Protocol	Modbus RTU (Slave)		Modbus TCP/UDP (Server)
Size (W × H × L) (mm)	33 × 107 × 78	52 × 93 × 27	52 × 85 × 27

# IR Controlled Power Relay Module



**IR-310-RM**

IR-310-RM is an IR-controlled 10-channel high power relay module designed for the power control of various appliances. The application field can be manual/automatic power switch, light scenario control and energy saving etc.

Model Name	IR-310-RM
Relay Output	10 outputs (Form C)
Contact Rating	5 A @ 220 VAC × 6; 10 A @ 220 VAC × 4 (Operating temperature: 25°C)
Protocol Interface	Modbus RTU RS-232, RS-485
IR Commands	Self-defined: 64; built-in 32
IR Input	On-board IR receiver / Audio jack

**Features:**

- 10 channels high power relays
- Supports IR commands for relay control
- NO & NC terminals for each channel
- Protection circuit for each channel
- Sequential relay control
- Support max. 5 sets of interlocked relay pairs
- Power-on values and power failure memory

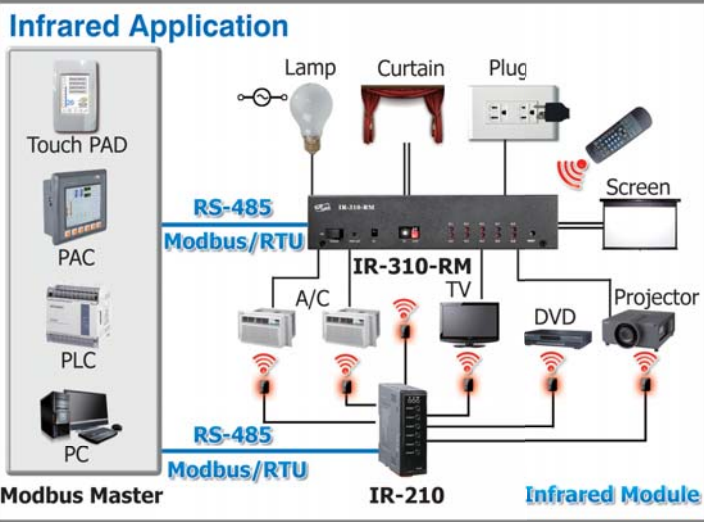

**IR Accessories & Usages:**

IR series modules need to equip with an IR signal cable in order to transmit or receive infrared remote control signals. ICP DAS provides single-headed, dual-headed and semi-sphere-headed first-class IR cables to meet different wiring requirements. IR cable can be extended the distance according to the actual wiring situation.

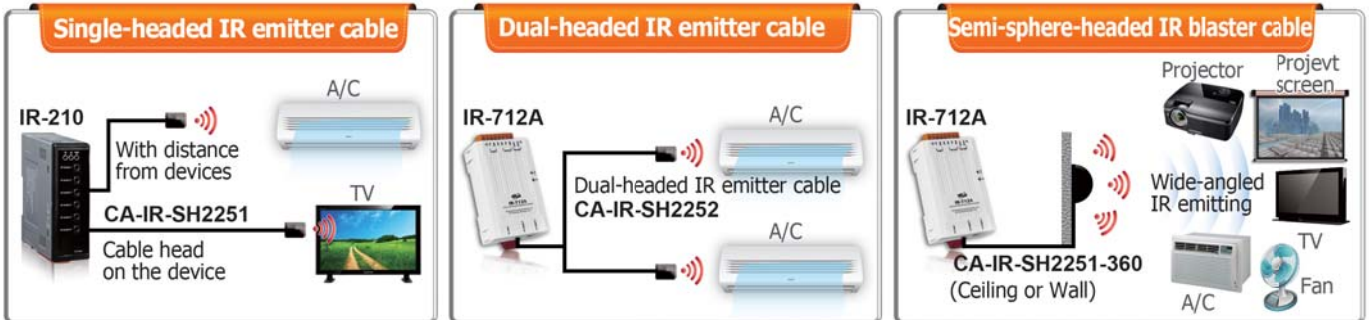





Model Name	Description	Model Name	Description
<b>CA-IR-SH2251</b>	Single-headed IR emitter cable (with adhesive pad, Ø 3 mm IRED, 2.5 m)	<b>CA-IR-SH2251-360</b>	Semi-sphere-headed IR blaster cable (with adhesive pad, 2.5 m)
<b>CA-IR-SH2252</b>	Dual-headed IR emitter cable (with adhesive pad, Ø 3 mm IRED, 2.5 m)	<b>CA-IR-SH1251-360</b>	Semi-sphere-headed IR receiver cable (with adhesive pad, 2.5 m)
<b>CA-IR-SH2251-5</b>	Single-headed IR emitter cable (with adhesive pad, Ø 5 mm IRED, 2.5 m)	<b>CA-IR-001</b>	IR receiver cable, 3 m
<b>CA-IR-SH2252-5</b>	Dual-headed IR emitter cable (with adhesive pad, Ø 5 mm IRED, 2.5 m)	<b>L108E</b>	IR learning remote control

<Note> The IR emitter cable can be extended up to 100 meters by Ethernet CAT 5 cable.



# 10 Wireless Modbus Data Concentrators

MDC stands for Modbus Data Concentrator. ICP DAS MDC product line is designed to group and boost the low communication speed products to Ethernet.

Model Name		MDC-700 Series	MDC-211-WF	MDC-211-ZT	MDC-211-433
Pictures					
Wireless	Standard	N/A	Wi-Fi	ZigBee	Radio Frequency
	Frequency	N/A	2.4 GHz	2.4 GHz	433 MHz
	Specialized I/O modules	N/A	WF-2000 series	ZT-2000 series	Regular RS-232/485 I/O modules with RFU-433
RS-232		1 ~ 7	1	1	1
RS-485		1 ~ 4	1	1	1

## 433 MHz Modbus Data Concentrator



**MDC-211-433**

### Features:

- 433MHz Radio Frequency
- Support the Modbus RTU/TCP protocol
- Accelerate the Reading of Multiple Modbus RTU Devices
- Modbus Polling Commands for up to 240 definitions
- Data pool for up to 9600 Modbus Registers for each DI/DO/AI/AO
- Support Radio Frequency, Ethernet and RS-232/485

### Introduction:

MDC-211-433 is a Modbus data concentrator developed by ICP DAS, with Ethernet, 433MHz Wireless, RS-232 and RS-485 communication interfaces, can link the Modbus RTU devices to the Ethernet network. MDC-211-433 can read the data of Modbus RTU device according to the user-defined command table, and integrate the data of different Modbus RTU devices into the format of the continuous address so that the remote monitor host can connect to MDC-211-433 from Ethernet to access the data of multiple Modbus RTU devices at once. Through MDC-211-433's Modbus data centralized management function, as well as the Ethernet network convenient link and the communication ability, it can quickly establish a stable remote monitoring system, simplify the complexity during the process of data acquisition operation, reduces the Ethernet network traffic load, and enhances the system efficiency.

### System Structure:

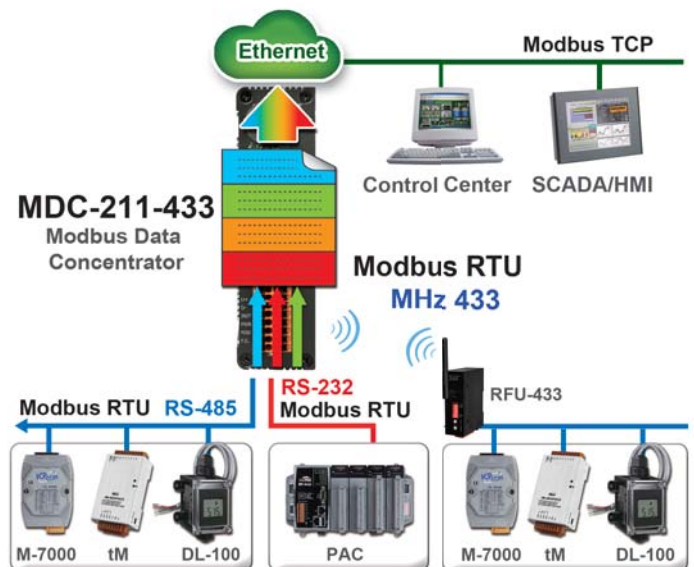

# Wi-Fi Modbus Data Concentrator



**MDC-211-WF**

**Features:**

- Compatible with IEEE 802.11 a/b/g standards
- Support Infrastructure and Limit-AP mode
- Support WEP, WPA and WPA2 encryption mechanism
- Support the Modbus TCP/RTU protocol
- Compatible with WF-2000 I/O modules
- Support Ethernet, RS-232/485 and Wi-Fi interfaces

**Introduction:**

MDC-211-WF is a Modbus Data Concentrator used to access data from disparate Modbus slave devices with a contiguous Modbus address table ranged by the concentrator. Up to 240 Modbus commands can be performed to read data from Modbus slave devices via Wi-Fi/RS-232/485, and up to 6 Modbus/TCP masters are allowed to get the polled data via the Ethernet. The Modbus/TCP masters directly read/write the data in the MDC-211-WF instead of polling each Modbus slave device one by one. This way not only makes the data on the Wi-Fi/RS-232/485 sharable to multiple Modbus/TCP master but also shorten the time to read/write data from/to multiple Modbus/RTU slave devices.

**System Structure:**

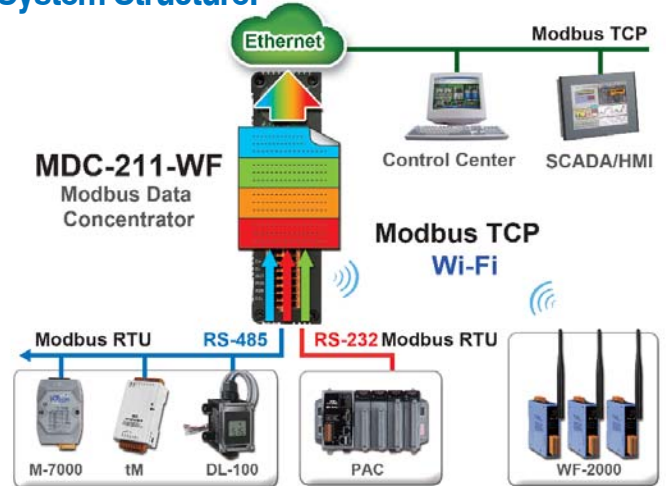

# ZigBee Modbus Data Concentrator



**MDC-211-ZT**

**Features:**

- Fully Compliant with 2.4 G (IEEE802.15.4/ ZigBee Specifications)
- Upgrade ZigBee I/O modules with Ethernet communication ability
- Support the Modbus TCP/RTU protocol
- Support the MQTT v3.1 Client protocol
- Support I/O data logger (MicroSD) function
- Data pool for up to 9600 registers
- Modbus polling commands for up to 240 definitions
- Speed up the time for reading from ZT-2000 series modules
- Support ZigBee, Ethernet and RS 232/485 interfaces

**Introduction:**

MDC-211-ZT is a Modbus Data Concentrator used to centrally manage decentralized I/O data via the ZigBee wireless mesh network. It access data from disparate Modbus slave devices with a contiguous Modbus address table ranged by the concentrator. Up to 240 Modbus commands can be performed to read data from Modbus slave devices via ZigBee/RS-232/RS-485, and up to 8 Modbus/TCP masters are allowed to get the polled data via the Ethernet. This way not only makes the data on the ZigBee/RS-232/RS-485 sharable to multiple Modbus/TCP master but also reduce the flow of ZigBee/Ethernet traffic load to improve the system performance. It is the best solution for users quickly establishing a remote monitoring system.

**System Structure:**

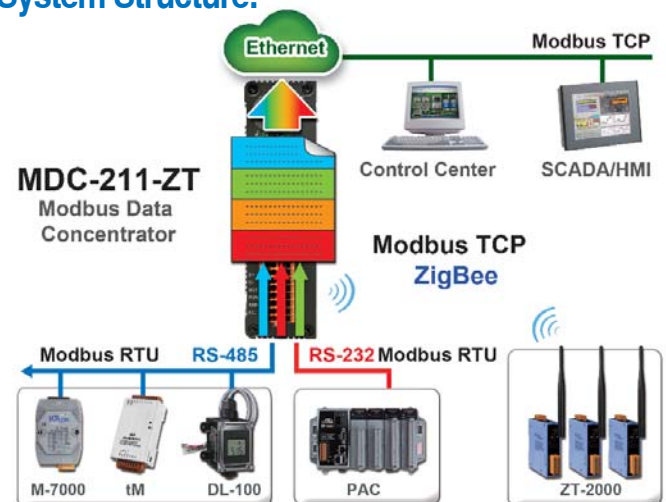

# 11. WLS (Wireless Locating System)

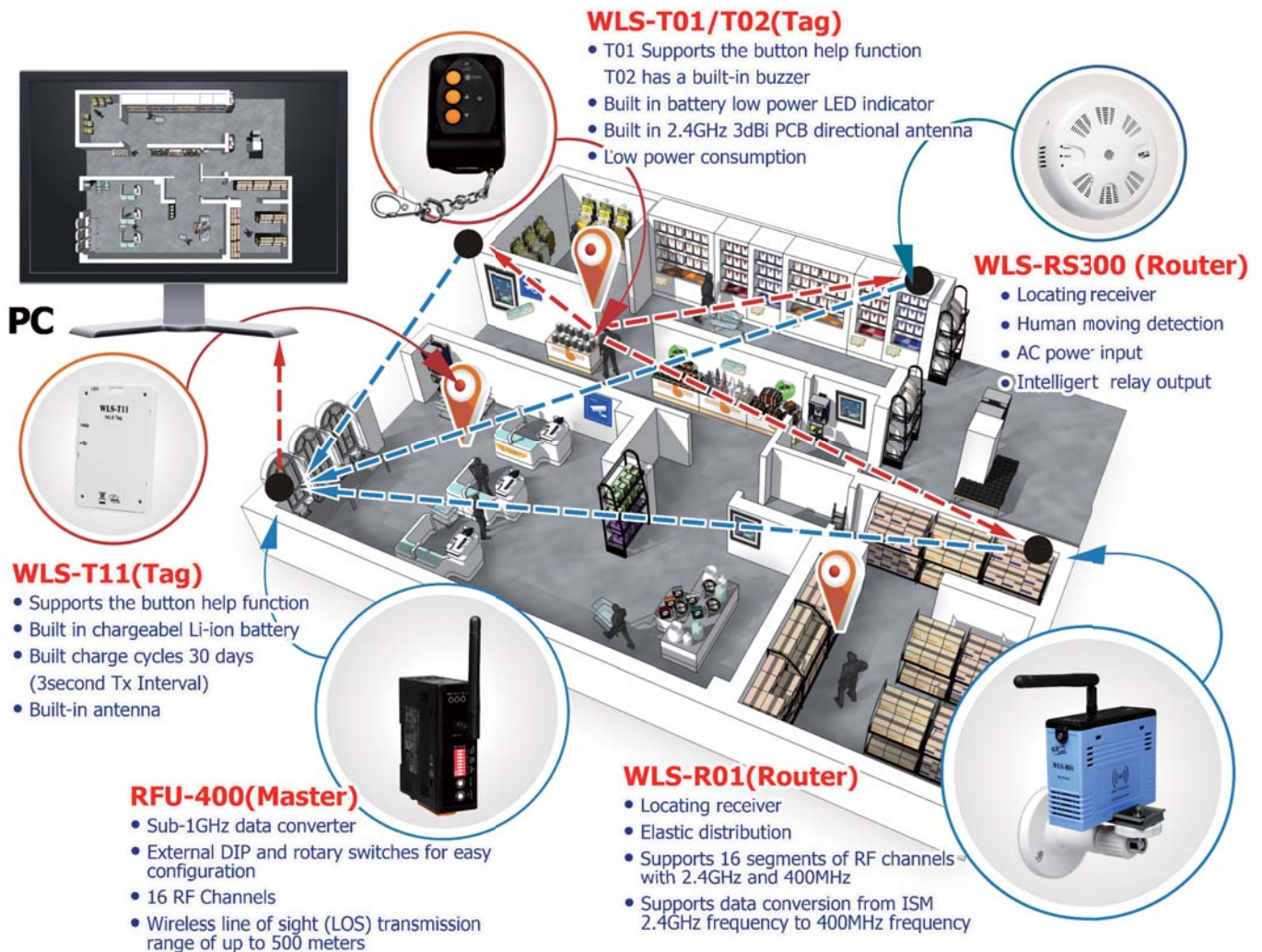

## Introduction:

Wireless Locating System can be used in indoor and outdoor environments. It can monitor the exact location of certain objects or persons and integrate the location information into the back-end servers. In addition, it combines the emergency applications and makes those who call help can be found immediately. And then, the WLS becomes a safety-based locating system. The WLS can be used in industrial or commercial applications, such as: the large commercial offices, the shopping malls, the high-voltage electrical room, the toxic gas room, the ultra-high temperature processing factories, the hospitals or care centers and etc. The customers in the shopping mall probably are changing consumer behavior. Does the store supervisor grasp your opportunity yet? Maybe there are unscrupulous visitors to stroll inside offices or wrongdoing, do you find it? Someone is in danger and calling help in the hazardous working area, do you feel that? Patients who stay in the bathroom or toilet has exceeded the normal time, do you find the situation? These problems are difficult to detect and may cause harm to people or to the enterprise. The WLS could help to find out the problems and provide the efficient way to manage them.



Emergency Notification



Hot zone analysis



Asset Finder



Visitor Management



Tracking



Restricted Area

## Locating Principle:

The WLS utilize the wireless of the active-base 2.4GHz locators (Tag) which transferred by the receivers (Router). The WLS retrieves the first three stronger signals of the Routers and use the triangulation algorithm to estimate the location of the Tag. In another words, the top three closer Routers could indicate where the Tag is. In the 10 m \* 10 m space, one receiving station is arranged in each of the four corners, and the positioning accuracy can reach 3 m ~ 5 m. Here shows the illustration.

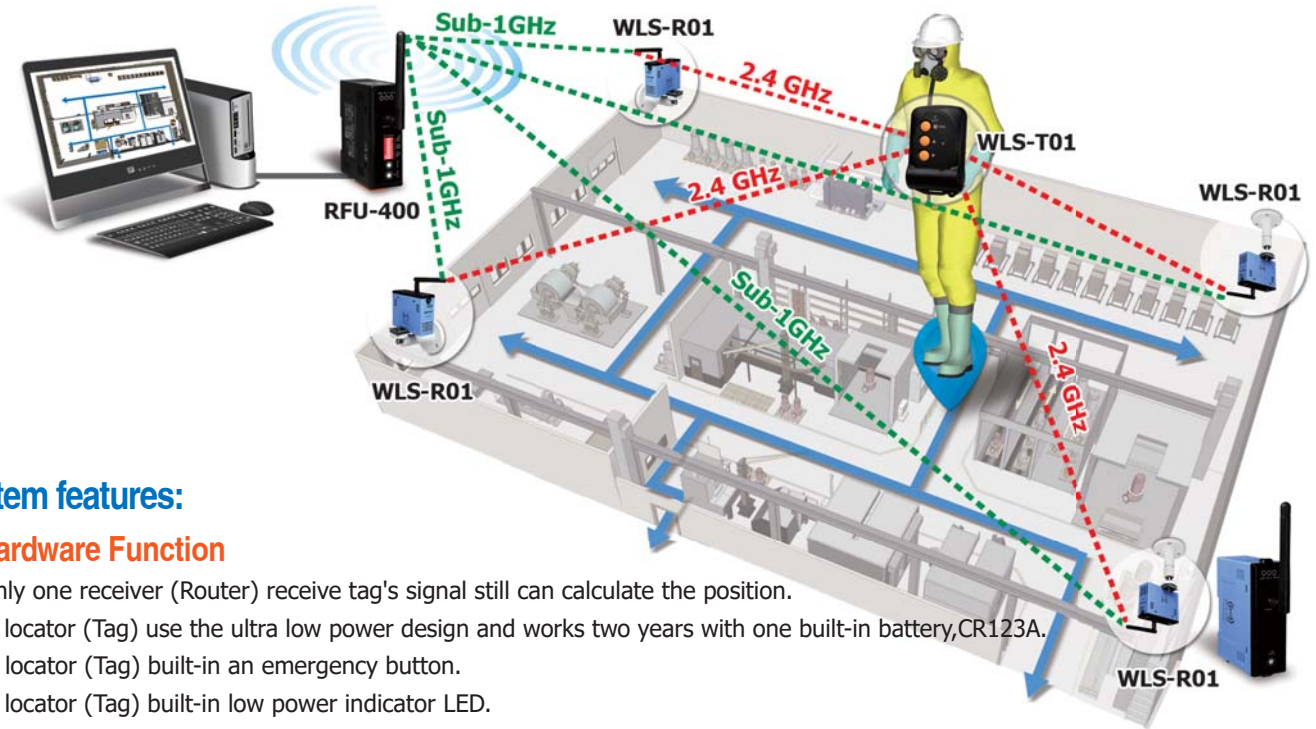

## System features:

### ★ Hardware Function

- 1.If only one receiver (Router) receive tag's signal still can calculate the position.
- 2.The locator (Tag) use the ultra low power design and works two years with one built-in battery,CR123A.
- 3.The locator (Tag) built-in an emergency button.
- 4.The locator (Tag) built-in low power indicator LED.
- 5.To avoid wireless data collision, the locator(Tag) has smart data collision algorithm.
- 6.The receiver (Router) / locator (Tag) supports 16 RF channels.
- 7.The receiver (Router) transfers data to server by the Sub-1GHz wireless signal.
- 8.The distance between receiver (Router) and locator (Tag) is up to 100 meters (line of sight,LoS)

### ★ Software Function

1. Supports Windows XP/ Win7 / Win10.
2. With graphical and friendly UI, the software indicates all real time locations.
3. Support changing indoor map and indicating the position of the Routers.
4. To receive data from all tags and indicate their positions.
5. The green icon is normal. The red icon shows the person is calling help.  
The yellow icon is the low power tag.
6. The software will save the emergency record and alert immediately.
7. The software will save the moved path to the files.

8. Big data can analyze more useful data for multiple scenarios (coming soon).  
Application: Factory or enterprise visitor management, visitors mistakenly banned the statistics of the restricted area, and the moving track of jointer and visitors, worker management in hazardous areas, workers' long-term static warnings, and workers' security patrol tracks, etc.

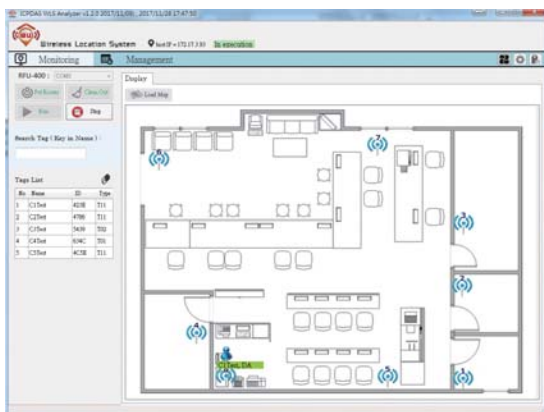

# Various System Topologies

## Sub-1GHz Topology (Serial Port)

### Sub-1G Topology (Serial Port)

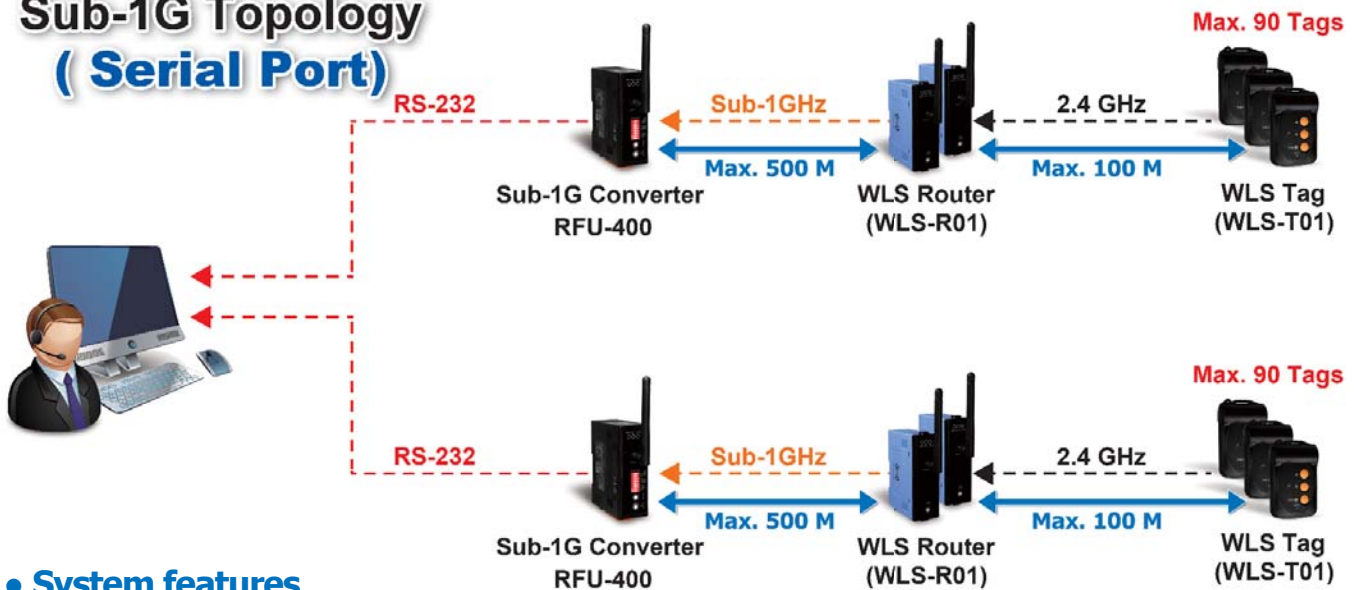

#### • System features

1. The Routers (WLS-R01) need only DC power to achieve wireless forwarding function.
2. The PC can poll wirelessly the locating data through Sub-1G converter (RFU-400).
3. The distance is 500 meters (LoS, Line of Sight) between the WLS-R01 and the RFU-400.
4. It is suitable for small field with 2~3 sections. It supports 90 tags within single section.

## Sub-1G Topology(Ethernet)

### Sub-1G Topology (Ethernet)

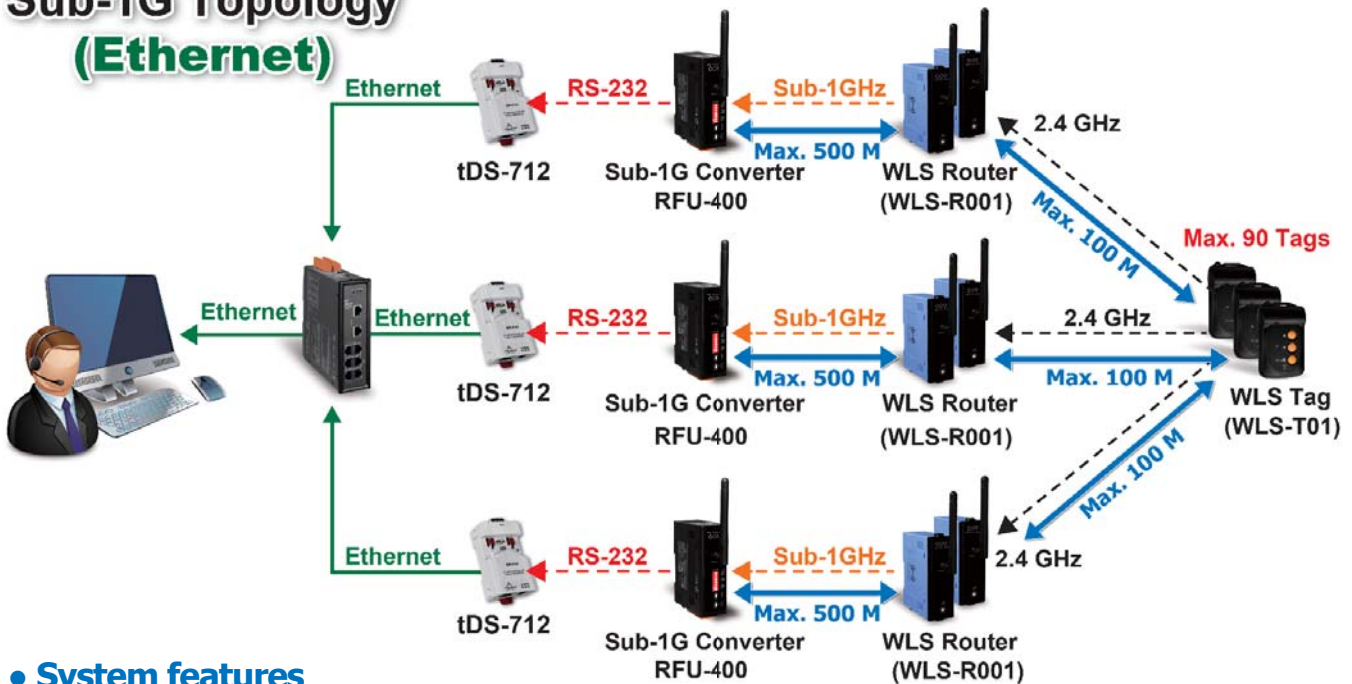

#### • System features

1. The Routers (WLS-R01) need only DC power to achieve wireless forwarding function.
2. The PC can poll the locating data of Routers (WLS-R01) via multi tDS-712 (Serial to Ethernet device) and RFU-400.
3. The distance is 500 meters (LoS, Line of Sight) between the WLS-R01 and the RFU-400.
4. It is suitable for large field with hundreds of sections. It supports 90 tags within single section.

2.4G Topology(Ethernet)

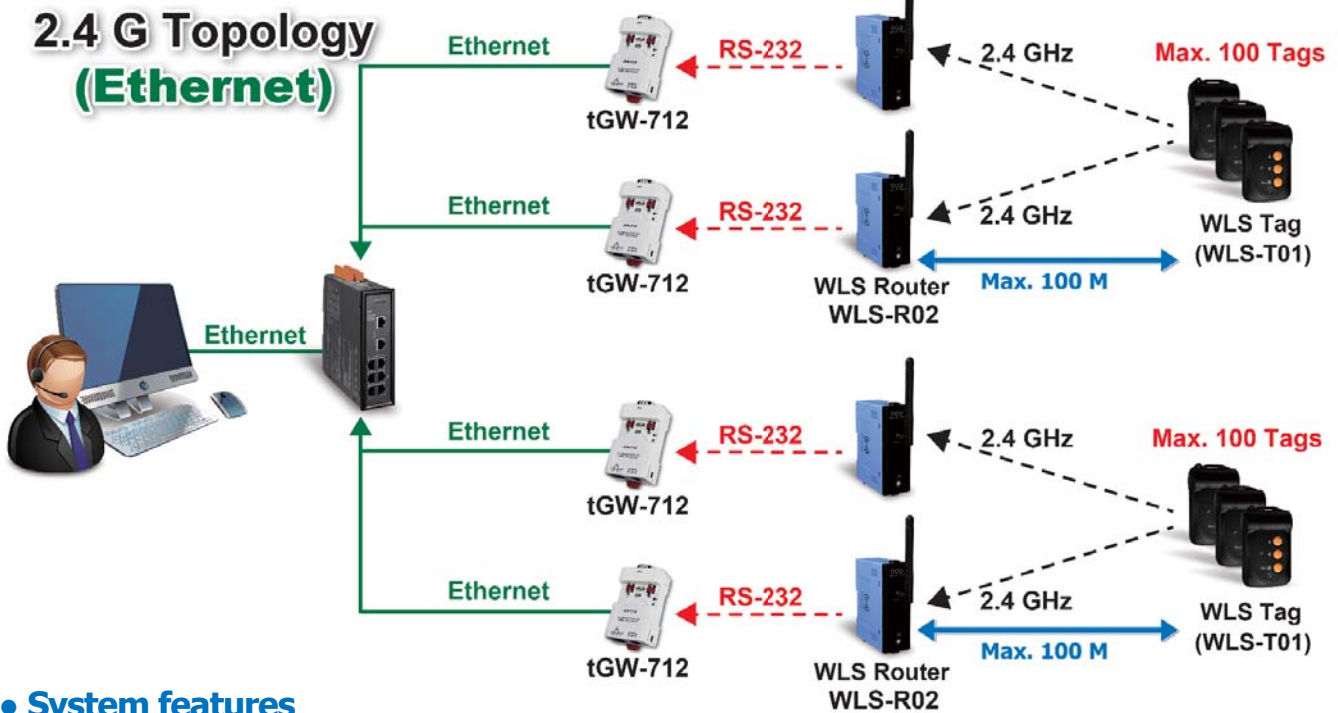

• System features

1. The Routers (WLS-R02) need only DC power to achieve wireless forwarding function.
2. The PC can poll the locating data of Routers (WLS-R02) via multi tGW-712 (Modbus TCP to Modbus RTU gateway).
3. It is suitable for large field with hundreds of sections. It supports 100 tags within single section.

2.4G Topology (Wi-Fi)

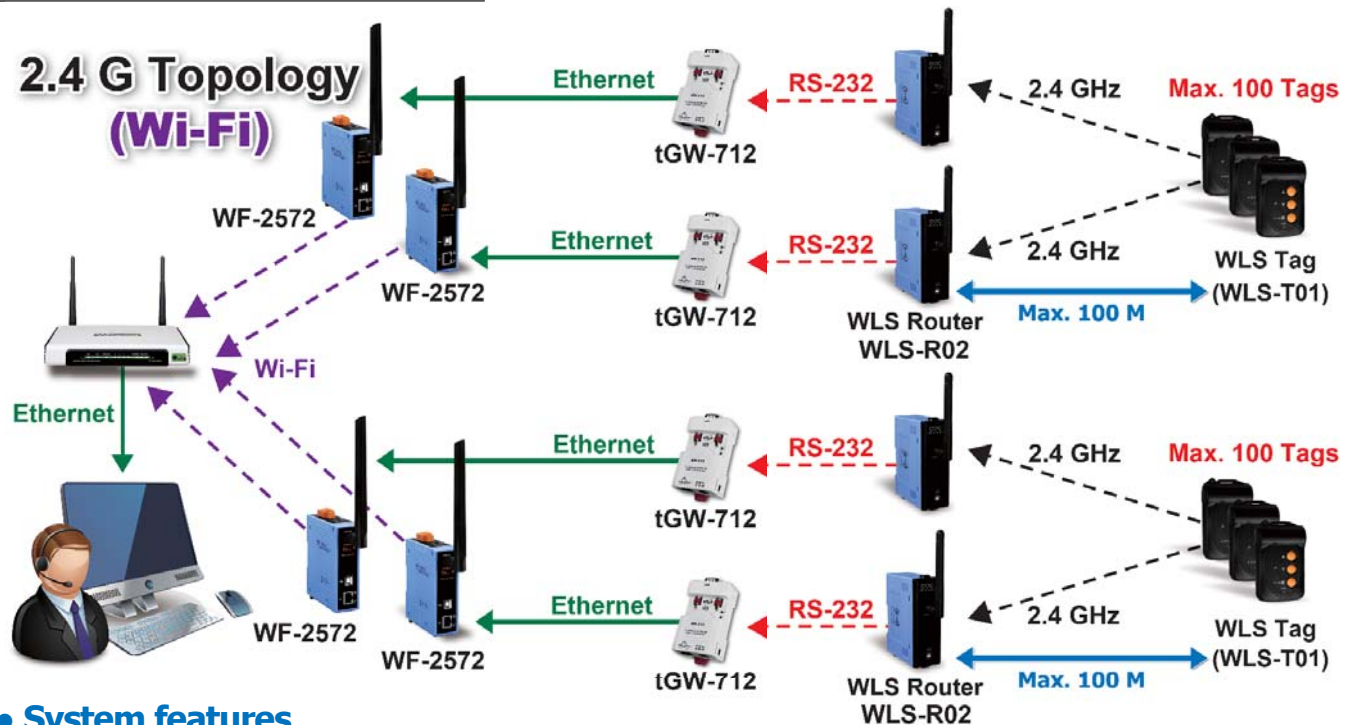

• System features

1. The Routers (WLS-R02) need only DC power to achieve wireless forwarding function.
2. The PC can poll multi receiver (WLS-R02) via WF-2571 (Wi-Fi to Ethernet converter) and multi tGW-712 (Modbus TCP to Modbus RTU gateway).
3. It is suitable for large field with hundreds of sections. It supports 100 tags within single section.

## Comparison Table:

Item \ Topology	Sub-1G (Serial Port)	Sub-1G (Ethernet)	2.4G (Ethernet)	2.4G (Wi-Fi)
Tag	WLS-T01	WLS-T01	WLS-T01	WLS-T01
Tag amount per-section	90	90	100	100
Router	WLS-R01	WLS-R01	WLS-R01 + tGW-712	WLS-R01 + tGW-712 + WF-2572
Router Communication	Sub-1GHz (Penetrating cement wall is supplied)	Sub-1GHz (Penetrating cement wall is supplied)	Ethernet	Wi-Fi
Master	RFU-400	RFU-400 + tDS-712	None	None
PC location	Near the site	Far away the site	Far away the site	Far away the site
Field	Small field	Large field	Large field	Large field
Sections	2 ~ 3	More than one hundred	More than one hundred	More than one hundred



**RFU-400**  
Wireless Modem

- 42 MHz Radio Frequency
- 16 RF Channels
- Includes a PA switch that can be used to enhance the RF power
- Wireless line of sight (LOS) transmission range of up to 1000 meters at an RF Baud Rate of 9600 bps
- Transparent transmission mode
- Provides Baud Rates from 1200 to 115200 bps for both the RS-232 and RS-485 interfaces
- DIN-Rail mountable



**WLS-R01**  
Wireless Receiver

- Supports data conversion from ISM 2.4 GHz frequency to 400 MHz frequency
- Supports 16 segments of RF channels with 2.4 GHz and 400 MHz
- Supports RSSI filtering function
- Built in 2.4 GHz 3 dBi PCB directional antenna
- 2.4 GHz wireless transmission range up to 100 m (Line of Sight)
- 400 MHz wireless transmission range up to 500 m (Line of Sight)
- Supports external DIP and rotary switches for easy configuration
- DIN-Rail mountable



**WLS-T11**  
Wireless Transmitter

- Supports the button help function
- Built in battery low power LED indicator
- Built in 2.4 GHz 3 dBi PCB directional antenna
- ISM 2.4 GHz operating frequency
- Direct Sequence Spread Spectrum (DSSS) RF technology
- Wireless transmission range up to 50 m (Line of Sight)
- Built-in chargeable Li-ion battery
- Battery charge cycle: 30 days (3 second Tx Interval)
- Supports 16 segments setting of RF channels
- Supports 16 segments setting of RF power



**WLS-RS300**  
Wireless Receiver

- Supports data conversion from ISM 2.4 GHz frequency to 400 MHz frequency
- Supports 16 segments of RF channels with 2.4 GHz and 400 MHz
- Built in 2.4 GHz 3 dBi PCB directional antenna
- Supports external DIP and rotary switches for easy configuration
- Built in a buzzer and supports remote enabling buzz function
- Provides relay output, can be connected to the alarm light



## WLS-T01

Wireless Transmitter

- Supports the button help function
- Supports 16 segments setting of RF channels
- Supports 16 segments setting of RF power
- Built in battery low power LED indicator
- Built in 2.4 GHz 3 dBi PCB directional antenna
- ISM 2.4 GHz operating frequency
- Direct Sequence Spread Spectrum (DSSS) RF technology
- Wireless transmission range up to 100 m (Line of Sight)
- Low power consumption design (1 pcs CR123A battery, when operating temperature from +20°C~+60°C, it can be used 2 years)



## WLS-T02

Wireless Transmitter

- Built in a buzzer and supports remote enabling buzz function
- Supports 16 segments setting of RF channels
- Supports 16 segments setting of RF power
- Built in battery low power LED indicator
- Built in 2.4 GHz 3 dBi PCB directional antenna
- ISM 2.4 GHz operating frequency
- Direct Sequence Spread Spectrum (DSSS) RF technology
- Wireless transmission range up to 100 m (Line of Sight)
- Low power consumption design (1 pcs CR123A battery, when operating temperature from +20°C~+60°C, it can be used 1 years)

### Factory or business (visitor management)

There are lots of visitors or technical survey in the factories or offices. Usually, the security make the visitors to wear identify card. But visitors may go to the danger zone or to the confidential area for illegal activity. Those headache problems are difficult to against or to alert in time. Here show the solutions of the WLS.

- 1.The visitors can be worn the identify card and WLS tag. The real time position of the visitors could be shown and recorded.
- 2.The employee which has received their visitor can also ware WLS tag. The manager could know whether the employee is in contact with the visitor by the position of the tag.
- 3.When visitors moving into the hazardous area or sensitive areas, it can be found and be alerted immediately.
- 4.When visitors feel illness or need help, they can press the emergency button to call help. It could reduce or avoid industrial accidents.





## Hazardous Working Environment (Security Management)

The factories will always have dangerous working areas, such as: high voltage electric room, toxic gas zone, ultra-high temperature operation area and etc. The employees who are working in this area need to be monitored for their safety or for compliance with safety regulations. When the accident happening, the manager can deal with instantly or notify other persons immediately. When working in hazardous areas and wear the tag, the manager can know how many persons in the area and where the persons are. When the persons need to call help, they can push emergency button to notify others. Toxic materials or controlled materials can be tied the tag. After using those materials, the manager can know whether the material has been put back to its place. When the industrial security patrols the hazardous area, the manager can track whether the security has been to the area or not or whether the important place has been checked or not.



# 12. iWSN Solution

## iWSN Series (Industrial Wireless Sensor Network)

### Semiconductor, electronics manufacturing

With the trend toward smart manufacturing and flexible manufacturing, the production process is becoming increasingly complicated, and each production stage is interlocked. The condition of the equipment is evaluated using the concept of predictive maintenance to maintain the operation of the production line. In response to the Internet of Things (IoT), big data analysis, Industry 4.0, energy-saving and carbon-reduction requirements, ICPDAS has developed the "Industrial Wireless Sensor Network" solution. In addition to integrating current, temperature measurement, and wireless transmission functions into a single module, the ultralow power consumption can be matched with a current transformer (CT) for inductive charging, it can meet the supply and demand balance of working power and supply the required continuous uninterrupted measurement equipment parameters with sufficient power. The settings can be completed using a DIP switch, which not only doesn't affect the production process, but also greatly saves system construction time and reduces maintenance costs. To meet the power consumption needs of monitoring equipment, predictive maintenance and power panel temperature monitoring, it's helpful to maintain the production line equipment and prevent accidents caused by the aging of power panel equipment and cables.

### ▼ Comparison between Traditional and iWSN methods

Item	Traditional Meter	iWSN Series
Main function	Measuring power parameter data	Measuring current, temperature and DI (Continuous development of vibration, gas detection, etc.)
Accuracy	<1%	<3% or ±0.3A
Cycle	At least once per second	1/10/30/60 seconds
Power	DC power provides an additional transformer AC power provides power lines	CT charging, battery storage (Easy to install and maintain, and easy to build)
Power configuration	100% (7W) (Wireless Module + Meter + Power Supply)	0.3% (20mW) Power saving design
Parameter setting	Software Utility	DIP switch setting
Hardware cost	General	Low
System defect	Long construction time, system needs to be powered off to be built, complicated to set up, and difficult to maintain	Easy functions, low data update speed
Application	Monitoring system, electricity billing, energy efficiency actuarial or power quality analysis	Big data analysis, system monitoring, trend analysis and predictive maintenance

### ▼ AC cable current required for supply and demand balancing

The built-in lithium battery in the iWSN is charged via the tiny current induced by the CT from the power line, and the power consumption of the lithium battery is related to the iWSN's wireless signal transmission period and whether there is an expansion module connected to the iWSN-700 module. Therefore, when building an iWSN data acquisition scheme, the current of the power line to be measured must be greater than the current value of the "balance between supply and demand". The current values for the supply and demand balance under different conditions are as follows:

Transmission Interval	iWSN-1110X iWSN-1120X	iWSN-1121-DI	iWSN-1131	iWSN-1110X+iWSN-750P iWSN-1120X+iWSN-750P	iWSN-1110X+iWSN-757P iWSN-1120X+iWSN-757P
1s	11A	12A	19A	20A	21A
10s	3A	5A	12A	12A	13A
30s	3A	4A	5A	11A	12A
60s	3A	4A	5A	11A	12A

## ▼ Features

### Wireless Sensing:

The iWSN wireless signal sensing module is fastened to the circuit being measured wire via the CT. The CT is usually in charging mode and can store the current received from the charging circuit in the battery. When the charging energy is greater than or equal to the power consumption, the wireless sensing module can operate continuously. If it is necessary to measure the current information from the power line, the module will automatically switch to operating mode to introduce the current signal into the circuit being measured. The result and state parameters for the module will be transmitted to the iWSN concentrator via wireless communication, and then the module will switch back to the charging state until the next measurement.

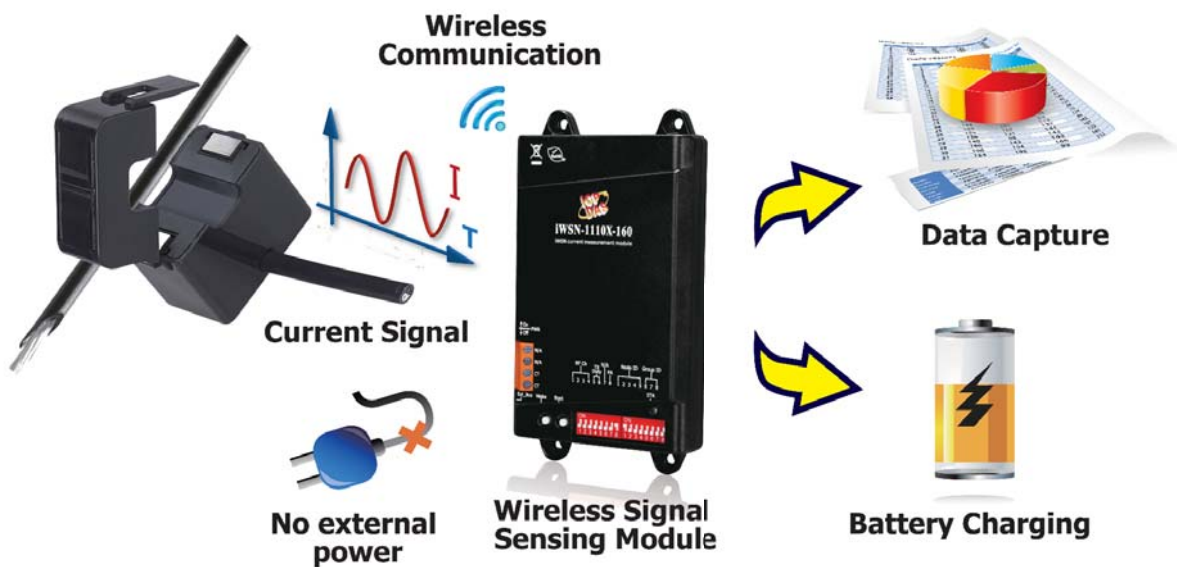

### Rapid Deployment:



## ▼ System Structure

The iWSN network system includes a wireless data concentrator and a wireless sensing module. If there are more signal points to be collected, the IO interface on the iWSN I/O expansion module can be used to connect to these devices. The information collected by the iWSN data concentrator can be used to provide information to the field personnel through the ICP DAS touch panel controller, or the data can be sent to the cloud via a WISE series IIOT smart controller, or even connecting to instant messaging software. For the connection between the field communication network and the backbone of the network, ICP DAS also provides a series of converters, allowing data to be instantly uploaded to the control center for subsequent big data analysis.



## ▼ Applications

### Machine Diagnosis:

- Use the iWSN-1110X-160 with the iWSN-757P to monitor current and temperature data.
- If a machine is working abnormally or is overloaded, and based on the relationship between the temperature of the machine and the current power consumption over an extended duration, an alarm will be issued and the fault can be eliminated to prevent more serious damage or loss of the machine caused by forced operations.

If the operation of the machine is not normal, both the current and the temperature follow certain rules. Abnormal data is very likely to indicate that the machine is not operating properly. If the machine is not immediately scheduled for maintenance, more serious damage may be caused to the machine, and may even affect the safety of the operator, resulting in accidents.

If it is discovered that the parts are worn out after the machine is repaired, you can prepare a maintenance plan and order the spare parts in advance so that the production capacity for the production line can be properly planned so as to prevent accidental production line stagnation and loss of raw materials.



## Monitoring the Utilization of a Machine:

- Use the iWSN-1121-DI-240 module to monitor the current data on the panel.
- The two CT channels on the iWSN-1121-DI-240 module are used to detect the total current consumption of both the device and the main motor so as to determine whether the machine is in either standby or running condition.

The floorspace of some factories is large and contains a lot of equipment. If the owner of the factory can keep track of the production status of each machine, the problem where the waiting time or standby time is too long can be avoided. The traditional method is for the employees to fill in the operating time themselves. Not only does it take time to organize this information, it is also impossible to control the artificial floating time behavior and dynamically understand the productivity of the production line machine. The iWSN network system provides the staff with an instant understanding of the operating status of the field production line, while, in addition, also giving an indication where any necessary raw materials need to be immediately replenished, allowing the machine to continue to operate efficiently and achieve optimal production capacity.



**iWSN-2200**

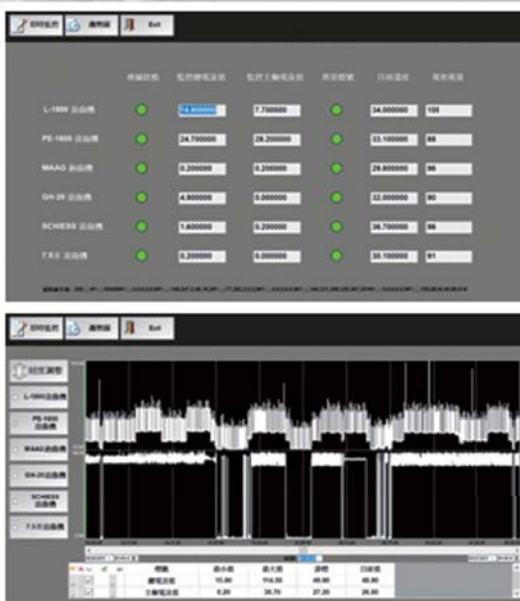

## ▼ Wireless Data Concentrator

The iWSN-2200 series collects and returns data from the sensor, and includes the Modbus RTU or Modbus TCP standard communication protocol that allows you to connect with upper system or graphics control software.

### iWSN-2200 Series Features:

- Supports 433 MHz Radio Frequency
- Provides 16 RF Channels
- Support Modbus RTU Protocol (Slave)
- ESD Protection:  $\pm 4$  kV Contact
- DIN-Rail Mounting
- Operating Temp.: -25 to +75°C
- Temporary storage for 31 sets of iWSN wireless signal sensing modules
- Isolation: 3000 VDC for DC-to-DC, 2500 Vrms for photo-couple



### Optional Accessories:

#### Antenna Base: NT-Base-02

Antenna Base/1500 mm



Magnetic installation



**External Cable: 3S001-1**  
RG58A/U 1 Meter Long RP-SMA male to RP-SMA Female

Module Name	iWSN-2200	iWSN-2200-E
<b>RF interface</b>		
Radio Frequency	433 MHz	
Channels	0 ~ 15 (set by DIP/Rotary Switch)	
Transmission Distance (LoS)	100 m	
Connectivity	Supports up to 31 iWSN wireless signal sensing modules	
<b>Communication</b>		
Interface	RS-232 or RS-485 × 1	Ethernet × 1
Protocol	Modbus RTU	Modbus TCP
Baud Rate	1200 ~ 115200 bps, N81, O81, E81	10/100 Mbps
<b>Mechanical</b>		
Dimensions (L × W × H)	108 mm × 84 mm × 33 mm (without antenna)	
Antenna Dimensions (L × Ø)	108 mm × 10 mm	
Installation	DIN-Rail Mounting	
<b>Other</b>		
Input Voltage Range	10 ~ 30 VDC	
Power Consumption	0.5 W	1 W
Operating Temperature	-25°C ~ +75°C	
Certification	CE+RED	CE



## ▼ Wireless Signal Sensing Module

In addition to the acquisition of energy data via the connected CT, the current value on the cable on the CT is also measured and transmitted back to the data concentrator via wireless communication.

### iWSN-1100 Series Features:

- Built-in rechargeable Li-ion battery power supply
- Li-ion battery can be charged using the CT
- The CT is easy to mount
- Supports up to 1000 amps of cable current
- Supports 433 MHz Radio Frequency
- Provides 16 RF channels
- Provides extended interface for flexibility and scalability
- Wall-mounting and magnetic mechanism for installation



Module	iWSN-1110X iWSN-1110X-160 iWSN-1110X-240 iWSN-1110X-360	iWSN-1121-DI-160 iWSN-1121-DI-240 iWSN-1121-DI-360	iWSN-1131P iWSN-1131-160 iWSN-1131-240 iWSN-1131-360	iWSN-1120X-360-RCT1000P iWSN-1120X-240-RCT1000P
<b>RF Interface</b>				
Radio Frequency	433 MHz			
Channels	0 ~ 15 (set via DIP Switch)			
Transmission Distance (LoS)	100 m			
<b>Split-Core CT specifications</b>				
CT Channels	1	2	3	1 (For charging only)
CT Input Voltage	50Hz / 60Hz · 500V 以下			
CT Type	Φ16 mm (100 A) · Φ24 mm (200 A) and Φ36 mm (400 A) (Note 1)			Φ24 mm (200 A)
CT Error	<3% or 0.3A			-
Rogowski Coil Channel	-			1
Rogowski Coil Input Voltage	-			50 Hz / 60 Hz · 500V 以下
Rogowski Coil Type	-			Φ80 mm (1000 A)
Rogowski Coil Error	-			3% or 2A
<b>Thermistor (Optional)</b>				
Channels	-	1	1	-
Measurement Range	-	0°C ~ 80°C	0°C ~ 80°C	-
Temperature Error	-	< 2 °C	< 2 °C	-
<b>DI specification</b>				
Channels	-	1	-	-
Type	-	Dry contact	-	-
<b>Mechanical</b>				
Dimensions (L × W × H)	152 mm × 85 mm × 36 mm			
Installation	Wall-mounting or magnetic mounting			
<b>Other</b>				
Battery	3.7 V, 800 mAh with 1.25 mm connector (UV, OV, Short protection)			
Operating Temperature	0°C ~ +45°C			
Expansion Interface (Supports the iWSN-700 series)	Yes	-	-	Yes
Certification	CE + RED	CE only	CE only	CE + RED

**Note 1:** The accessories for the iWSN-11□□□-160, iWSN-11□□□-240 and iWSN-11□□□-360 are Φ16 mm (100 A), Φ24 mm (200 A), and Φ36mm (400A).



## ▼ I/O Expansion module

The iWSN-700 series is an expandable CT and temperature measurement interface, which series connects to the sensing module via wireless communication, and transmits the value collected by the expansion module to the sensing module, or, further, to the data concentrator.

### iWSN-700 Series Features:

- Supports Multi-channel I/O Expansion
- Supports Split-Core CT using different measurement ranges
- Power is provided by the iWSN-1100X or iWSN-1120X sensing module
- Easy-to-maintain detachable screw terminal block
- Rail-mounting and magnetic mounting



Module	iWSN-750P	iWSN-757P
<b>Split-Core CT specifications (Optional)</b>		
Channels	5	
Input Voltage	50 Hz / 60 Hz, up to 500 V	
Type	Φ16 mm (100 A) 、 Φ24 mm (200 A) and Φ36 mm (400 A)	
Error	<3% or 0.3 A	
Form	Split-Core	
<b>Thermistor (Optional)</b>		
Channel	-	7
Measurement Range	-	0°C ~ 80°C
Temperature Error	-	< 2°C
<b>Mechanical</b>		
Dimensions (L × W × H)	115 mm × 72 mm × 35 mm	
Installation	Wall-mounting or magnetic mounting	
<b>Other</b>		
Operating Temperature	0°C ~ +45°C	
Certification	CE	

### Optional Accessories:



**CA-SCT16I-100A-L080**  
8 m, 100 A, Φ16 mm Split-Core CT



**CA-SCT24I-200A-L080**  
8 m, 200 A, Φ24 mm Split-Core CT



**CA-SCT36I-400A-L080**  
8 m, 400 A, Φ36 mm Split-Core CT



**CA-TM-M200-L050P**  
5 m Magnetic Plug Thermistor



**CA-TM-M100-L050P**  
5 m Metal Plug Thermistor



**CA-TM-P100-L020P**  
2 m Black Plastic Plug Thermistor



**CA-TM-P100-L050P**  
5 m Black Plastic Plug Thermistor



## ▼ Wireless Signal Sensing Module

iWSN wireless environment sensing series including wireless signal sensing module and expansion module. They are suitable to measure temperature/ Humidity/ CO<sub>2</sub>/ VOC/ CO/ Vibration. Power supply of iWSN Series include powering by CT or by DC. Different power supply can reduce the cost of wiring and maintenance.

Module	iWSN-1510X	iWSN-1511X
<b>RF Interface</b>		
Radio Frequency	433 MHz	
RF Channel	0 ~ 15 (Selectable by DIP Switch)	
Transmit. Distance	Line of sight up to 100 Meters	
Transmit. Cycle	1 / 10 / 30 / 60 Secs. (Selectable by DIP Switch)	
<b>Thermistor (Optional)*</b>		
Channels	-	1
Measurement Range	-	0 °C ~ +80 °C
Temperature Error	-	< 2 °C
<b>Power Supply</b>		
Split-Core CT	CT Φ10 mm (60 A); CTΦ16 mm (100 A); CTΦ24 mm (200 A); For charging only	
DC Power Supply	1~3 VDC , 1A	
<b>Mechanism</b>		
Dimensions	152 mm × 85 mm × 36 mm (L × W × H)	
Installation	Wall-mounting / Magnetic mounting	
<b>Others</b>		
Battery	3.7 V, 800 mAh with 1.25 mm connector ( UV, OV, Short circuit protection)	
Operation Temp.	0°C ~ +45°C	
Expansion Interface	Yes. Support iWSN-000 iWSN-100 iWSN-200	

## ▼ Emergency Button

**iWSN-SOS-PB**

Indoor Emergency Button

**iWSN-SOS-PB-IP65**

IP65 rated Water-Proof  
Emergency Button

### iWSN-SOS Features:

- True RMS Power Measurements
- Powered by built-in disposable lithium batteries
- Support 433MHz Radio Frequency
- Selectable 16 Radio Frequency Channels
- Provide Wall-mounting Installation

Module	iWSN-SOS-PB	iWSN-SOS-PB-IP65
<b>RF Interface</b>		
Radio Frequency	433 MHz	
RF Channel	0 ~ 15 (Selectable by DIP Switch)	
Transmit. Distance	Line of sight up to 50 Meters	
Transmit. Cycle	1 / 3 / 5 / 10 Mins. (Selectable by DIP Switch) ; 1 Sec.(Emergency Triggered Only)	
<b>Mechanism</b>		
IP Rated / Installation	138 mm × 92 mm × 52 mm	146 mm × 85 mm × 95 mm
Installation	-- /Wall-mounting	IP65 /Wall-mounting
<b>Others</b>		
Battery	1 × CR123A (3.0 VDC); Battery Life: 2 years (Transmit. Cycle: 1 Min.)	
Operation Temp.	-25°C ~ +60°C	

## Application-Wireless Vibration Monitoring:

Connect iWSN-1510X with iWSN-201 or iWSN-203 to monitor the vibration of Machinery and Motor. With a long-term records, when the analysis software receive data abnormal, iWSN-1510X will send alarms to notify the maintenance of machinery to prevent shutting down.

- This is suitable for sampling low-frequency rotating equipment, and time selectable (1/10/30/60 seconds) cycle measurement to achieve real-time faulty warning.
- Wireless transmission for easy installation and maintenance.
- Edge computing.
- Low power consumption.

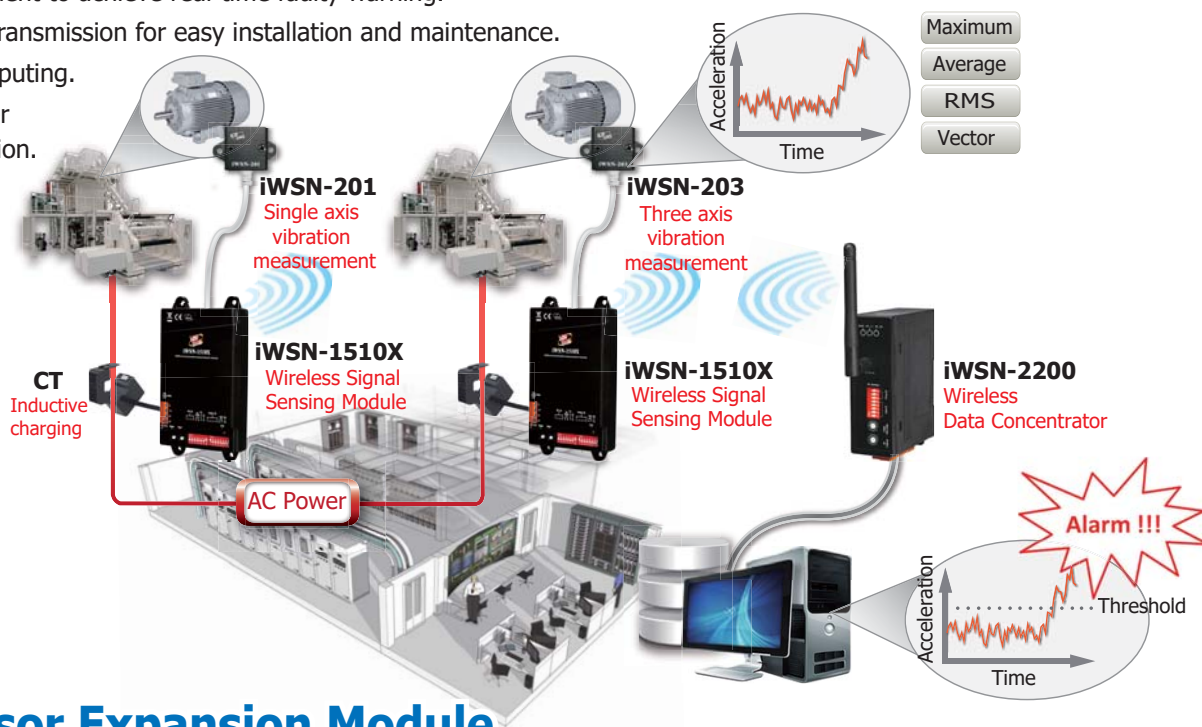

## ▼ Sensor Expansion Module

Module	iWSN-010 Humiture Sensor	iWSN-012 VOC/CO2 Sensor	iWSN-101 CO Sensor
Product Picture			
<b>Sensing Parameter</b>			
T.	Range	-20°C ~ +600°C	-
	Resolution	0.10°C	-
	Accuracy	±0.30°C	-
H.	Range	10 ~ 95% RH	-
	Resolution	±0.1% RH	-
	Accuracy	±3 % RH @ 20 ~ 80% RH	-
CO2 Sensing Range	-	400 ~ 8192 ppm	-
VOC Sensing Range	-	0 ~ 1187 ppb	-
CO Sensing Range	-	-	0 ~ 1000 ppm
<b>Mechanism</b>			
Dimensions (L × W × H)	25 mm × 20.2 mm × 30 mm		82 mm × 126 mm × 55 mm
Installation	Wall mount / Magnetic mount		Wall mount/ DIN-Rail
<b>Others</b>			
Operation Temp.	-20°C ~ +60°C	0°C ~ +45°C	

Module	iWSN-201 1-Axis Vibration Sensor	iWSN-203 3-Axis Vibration Sensor
Product Picture		
<b>Sensing Parameter</b>		
Type	1-Axis MEMS	3-Axis MEMS
Rate	Up to 10 kHz	Up to 1.5 kHz
Range	±8 g	
<b>Output Interface</b>		
Data Type (g)	Uniaxial RMS, Maximum	X, Y, Z axes of the RMS, the maximum value; triaxial vector value
<b>Mechanism</b>		
Dimensions (L × W × H)	51 mm × 30 mm × 15 mm	
Installation	Wall mount/ Magnetic mount	
<b>Others</b>		
Operation Temp.	0°C ~ +45°C	

# 13. No-touch Infrared Sensor Switch



**ACS-20W-MRTU**



**ACS-20B-MRTU**

**Features:**

- Special infrared coding to against interference
- Multiple operating modes: Sensing/Standby, Toggle Switch
- Double-color status indicator
- Induction distance: 1 ~ 15 cm
- Inductive action delay time: 0.5 ~ 20 sec
- With Relay (N.C. and N.O. output)
- The switches time recording: 1,000 records
- Switch can be enable/disable by Modbus RTU commands
- Communication interface and protocol: RS-485/Modbus RTU

The No-touch Infrared Sensor Switch from ICP DAS can be used to open a door using palm induction, which makes it more convenient when entering or exiting a room or building. The inductive distance and the delay time for door opening are adjustable, and has red and blue indicator lights to show the status of the switch. As people enter and exit the door using the No-touch Infrared Sensor Switches, a time stamp recording the action can be simultaneously logged.

The No-touch Infrared Sensor Switch includes an RS-485 interface and provides Modbus RTU communication, which can remotely enable/disable the switch and get the induction time records by the access control system.

Additionally, the No-touch Infrared Sensor Switch is not only used for access control system but also help you control other electronic devices. While it is triggered at the first time, the switch outputs ON signal, and next time outputs OFF signal.

The No-touch Infrared Sensor Switch can be used with electric doors to prevent issues related to the spread of infectious bacteria via touch. The switches can be used in medical institutions, retail stores, the food industry, industrial plants, and offices, etc. to provide an excellent sanitary environment.





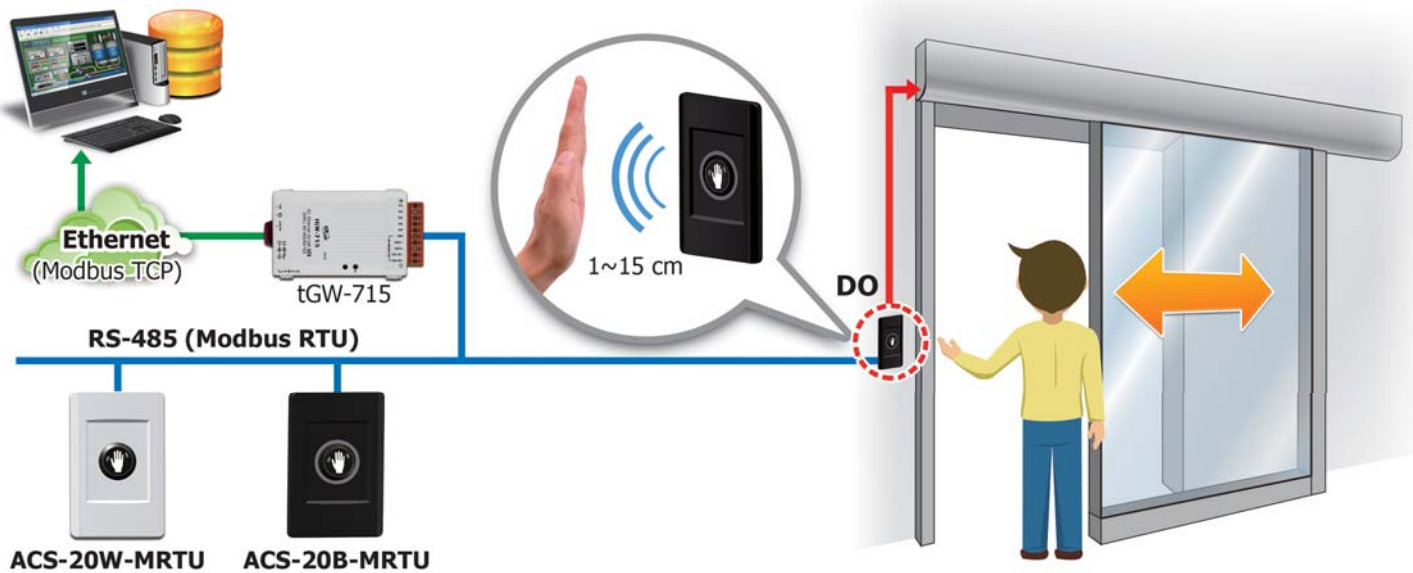
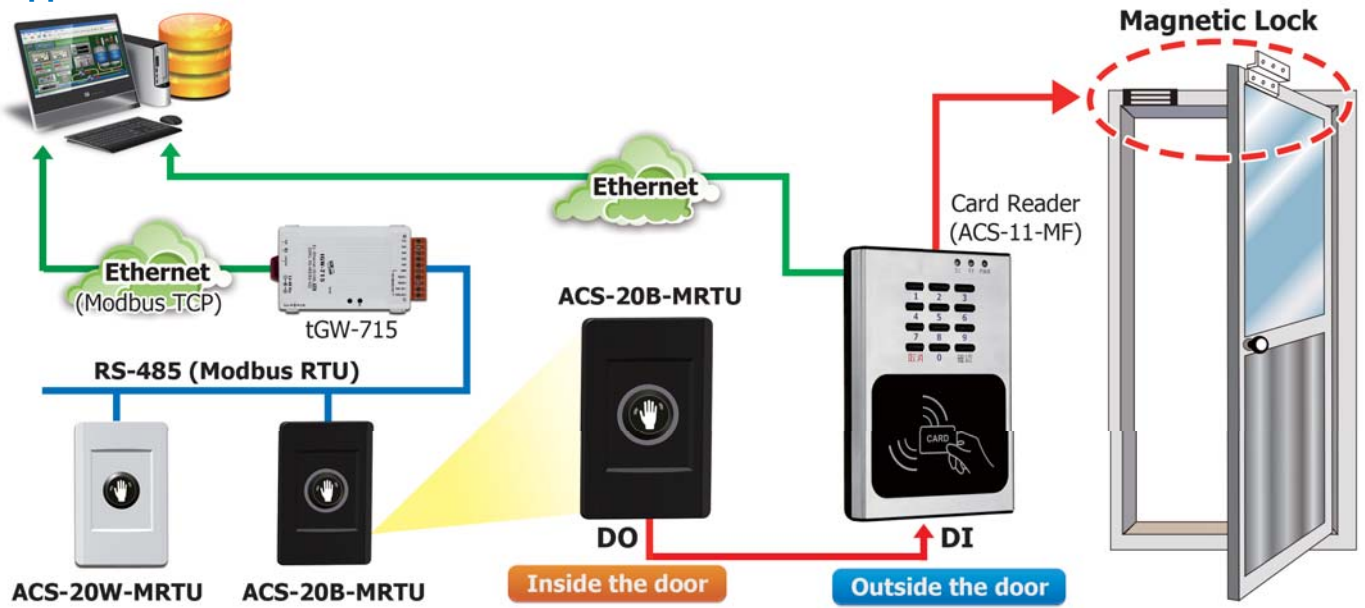

Specification		Description
Induction distance		1 ~ 15 cm (adjustable)
Inductive action delay time		0.5 ~ 20 sec (adjustable)
Indicator LED light		Red (Standby); Blue (Sensing)
Relay	Type	Form C
	Rated Current	0.5 A @ 120 VAC, 2 A @ 30 VDC
The switches recording times		1,000 records
Communication interface and Protocol		RS-485 / Modbus RTU
Power Input		+10 ~ +30 VDC
Dimensions (W × L × H)		75 mm × 119 mm × 24 mm

### Applications:



### External Wall Box and Outlet Box:

External Wall Box		Outlet Box	
 EWB-T28-BK		 OB120	
 EWB-T28			



## Energy Management Solution

- InduSoft
- Power Meter Concentrator
- Smart Power Meter
- True RMS Input Module
- Voltage Attenuator and Current Transformer: DN-800 Series
- iWSN Solution
- Portable Power Monitoring Suitcase



## IIoT Product

- IoTstar : cloud management software
- UA-5200 : communication server
- WISE series : IIoT host
- iCAM series : IP camera
- MQ-7200M series : MQTT I/O module
- Sensors : temperature, humidity, CO2, PM2.5,...

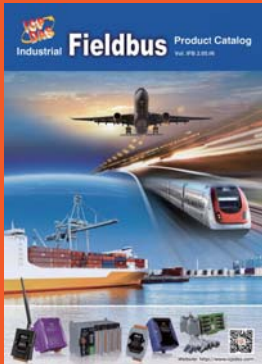

## Industrial Fieldbus

- RS-485
- Industrial Ethernet
- Profinet
- CAN bus
- CANopen
- Devicenet
- J1939
- PROFIBUS
- HART
- Ethernet/IP
- BACnet



## IIoT Cloud Solution - UA SERIES : IIoT Communication Server

- Built-in OPC UA Server Service
- Built-in MQTT Broker Service
- Support Logic Control IFTTT
- Support IoT Cloud Platforms Connection and IoTstar Cloud Management
- IIoT Factory Application of MES
- Pumping Station IoT Application
- BA Smart Building IoT Application
- Robotic Arm Co-operation Application

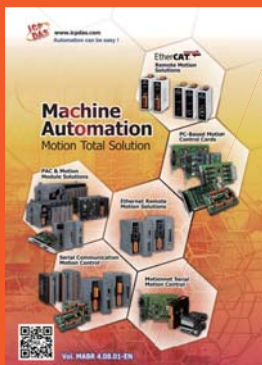

## Machine Automation

- Motionnet Solutions
- EtherCAT Motion Control Solutions
- Ethernet Motion Control Solutions
- Serial Communication Motion Control Solutions
- PC-based Motion Control Cards
- PAC Solutions - Motion Modules

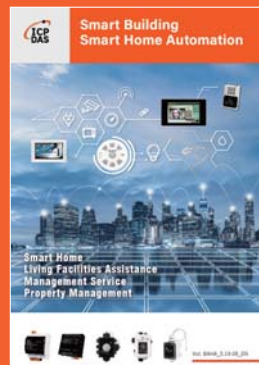

## Smart Building, Smart Home Automation

- Video Intercom & Access Control
- Touch HMI - TouchPAD Series
- Smart Lighting Control
- Energy Saving - PM/PMC Series
- Environmental - DL/CL Series
- Motion Detector - PIR Series
- Wi-Fi Wireless - WF Series
- Infrared Wireless - IR Series
- ZigBee Wireless - ZT Series
- IIoT Server & Concentrator
- LED Display - iKAN Series



## TouchPAD HMI Solutions

- Introduction
- TPD/VPD Products Series
- Video Intercom & Access Control Series
- TPD/VPD Application



## PC-based I/O Boards

- PCI Express Bus Data Acquisition Boards
- PCI Bus Data Acquisition Boards
- ISA Bus Data Acquisition Boards

