

iSN-81x Series User Manual

Version 1.3

July 2025



Product warranty

The warranty period for products manufactured by ICP DAS is one year from the date of delivery and applies to defective materials from the date of delivery.

Disclaimer

ICP DAS Technology Co., Ltd. shall not be liable for any damages caused by the application of this product. The Company reserves the right to change and modify the contents of this document at any time without prior notice. The information contained herein is subject to change without notice. The Company strives to provide accurate and reliable information, but does not warrant that the use of such information or other parties may infringe patents or rights. We are not responsible for technical or editorial errors or omissions contained herein.

Copyright

Copyright 2024 © ICP DAS Technology Co., Ltd

Trademark

All company trademarks, trade names and product names mentioned in this document are the property of their respective owners.

Technical services

If you have any questions, please contact our customer service. service@icpdas.com

Table of Contents

Table of Contents	1
1 Introduction	3
1.1 Product Features and Function Description	5
2 Hardware information	10
2.1 Specifications	10
2.2 Appearance (Wiring, DIP Switch, LED Status)	11
2.3 Dimensions.....	14
2.4 Accessories.....	14
2.5 Installation.....	15
3 iSN-81x-MRTU Configuration and Monitoring (Utility Software)	16
3.1 LiveList.exe : Find Online Devices	16
3.2 IR_Configuraion.exe : Configuration, Monitoring, and Diagnostics	18
3.2.1 Connecting to the iSN-81x-MRTU Module	18
3.2.2 Thermal Image & Area Status.....	19
3.2.3 Import image	22
3.2.4 Parameter Settings	23
3.2.5 Diagnostic Messages.....	25
3.2.6 Temperature Data Logging.....	26
4 iSN-81x-MTCP Configuration and Monitoring (Web)	29
4.1 Web Login	29
4.2 [Home]	31
4.3 [Settings]	33
4.3.1 IP Address Settings	34
4.3.2 Communication Settings.....	34
4.3.3 General Settings	37
4.3.4 Restore Factory Defaults	37
4.4 [Sensor]	38

4.4.1	IR Sensor Settings	39
4.5	[HeatMap]	40
4.6	[Chart]	43
4.7	[Calibration]	45
4.8	[Password].....	46
4.9	[Logout]	46
4.10	Forgotten Web Password.....	47
5	Modbus register table and JSON format	48
5.1	Modbus Command and register table	48
5.2	JSON Format.....	51
Appendix 1	Diagnostic Messages	52

1 Introduction

The iSN-81x-MRTU series is a sensor module specifically designed for non-contact temperature measurement applications. It offers a variety of thermal pixel configurations and flexible temperature threshold detection functions to meet the demands of various industrial and equipment monitoring scenarios. The product communicates using the standard Modbus RTU protocol, allowing seamless integration into SCADA systems for real-time temperature monitoring and data acquisition.

The iSN-81x-MTCP series provides even more diverse communication capabilities. In addition to supporting the Modbus TCP protocol, it also supports RESTful API, enabling real-time transmission of measurement data to remote databases for centralized storage and analysis. When operating as an MQTT Client, the iSN-81x-MTCP can actively publish measurement data to an MQTT Broker. SCADA systems, management platforms, or IoT applications can simply subscribe to the corresponding topics to receive sensor data in real time, thereby simplifying system integration and enhancing application flexibility.

The iSN-81x series offers a stable and efficient solution for industrial equipment monitoring, data analysis, and anomaly detection. With real-time temperature feedback, operators can quickly identify abnormal equipment conditions and take prompt action, reducing unexpected failures and minimizing production losses. In addition, long-term historical data storage can serve as a basis for automated decision-making or as a data source for AI model training, helping to achieve the goal of predictive maintenance.

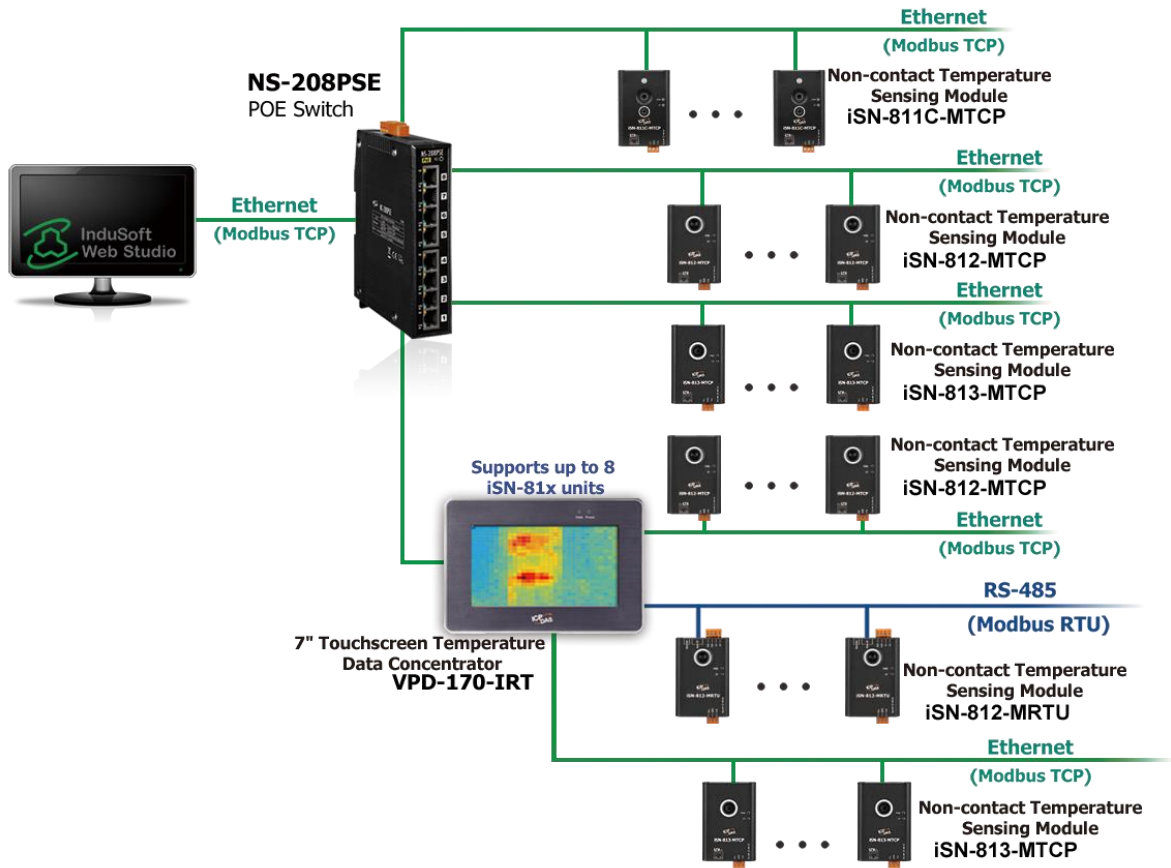

1.1 Product Features and Function Description

The iSN-81x series temperature sensors include multiple models, each differing in specifications such as resolution, measurement point arrangement, and field of view (FOV). To ensure accurate data acquisition and interpretation, users should refer to the specifications of each model and the following guidelines to meet the requirements and installation conditions of various monitoring scenarios.

■ Non-contact Multi-point Temperature Measurement

The temperature measurement resolution and the arrangement of sensing points vary depending on the model. Please refer to the table below for details.

Model	Pixel	Illustration																																																																																																																																																																																																																																																																																																																																																																																																																																																																																																																																																																																																																																																																																																																																																																																																
iSN-811C-MTCP	8 x 8 = 64	<table border="1"> <tr><td>57</td><td>49</td><td>41</td><td>33</td><td>25</td><td>17</td><td>9</td><td>1</td></tr> <tr><td>58</td><td>50</td><td>42</td><td>34</td><td>26</td><td>18</td><td>10</td><td>2</td></tr> <tr><td>59</td><td>51</td><td>43</td><td>35</td><td>27</td><td>19</td><td>11</td><td>3</td></tr> <tr><td>60</td><td>52</td><td>44</td><td>36</td><td>28</td><td>20</td><td>12</td><td>4</td></tr> <tr><td>61</td><td>53</td><td>45</td><td>37</td><td>29</td><td>21</td><td>13</td><td>5</td></tr> <tr><td>62</td><td>54</td><td>46</td><td>38</td><td>30</td><td>22</td><td>14</td><td>6</td></tr> <tr><td>63</td><td>55</td><td>47</td><td>39</td><td>31</td><td>23</td><td>15</td><td>7</td></tr> <tr><td>64</td><td>56</td><td>48</td><td>40</td><td>32</td><td>24</td><td>16</td><td>8</td></tr> </table>	57	49	41	33	25	17	9	1	58	50	42	34	26	18	10	2	59	51	43	35	27	19	11	3	60	52	44	36	28	20	12	4	61	53	45	37	29	21	13	5	62	54	46	38	30	22	14	6	63	55	47	39	31	23	15	7	64	56	48	40	32	24	16	8																																																																																																																																																																																																																																																																																																																																																																																																																																																																																																																																																																																																																																																																																																																																
57	49	41	33	25	17	9	1																																																																																																																																																																																																																																																																																																																																																																																																																																																																																																																																																																																																																																																																																																																																																																																											
58	50	42	34	26	18	10	2																																																																																																																																																																																																																																																																																																																																																																																																																																																																																																																																																																																																																																																																																																																																																																																											
59	51	43	35	27	19	11	3																																																																																																																																																																																																																																																																																																																																																																																																																																																																																																																																																																																																																																																																																																																																																																																											
60	52	44	36	28	20	12	4																																																																																																																																																																																																																																																																																																																																																																																																																																																																																																																																																																																																																																																																																																																																																																																											
61	53	45	37	29	21	13	5																																																																																																																																																																																																																																																																																																																																																																																																																																																																																																																																																																																																																																																																																																																																																																																											
62	54	46	38	30	22	14	6																																																																																																																																																																																																																																																																																																																																																																																																																																																																																																																																																																																																																																																																																																																																																																																											
63	55	47	39	31	23	15	7																																																																																																																																																																																																																																																																																																																																																																																																																																																																																																																																																																																																																																																																																																																																																																																											
64	56	48	40	32	24	16	8																																																																																																																																																																																																																																																																																																																																																																																																																																																																																																																																																																																																																																																																																																																																																																																											
iSN-812-MTCP iSN-812-MRTU	32 x 24 = 768	<table border="1"> <tr><td>32</td><td>31</td><td>30</td><td>29</td><td>28</td><td>27</td><td>26</td><td>25</td><td>24</td><td>23</td><td>22</td><td>21</td><td>20</td><td>19</td><td>18</td><td>17</td><td>16</td><td>15</td><td>14</td><td>13</td><td>12</td><td>11</td><td>10</td><td>9</td><td>8</td><td>7</td><td>6</td><td>5</td><td>4</td><td>3</td><td>2</td><td>1</td></tr> <tr><td>64</td><td>63</td><td>62</td><td>61</td><td>60</td><td>59</td><td>58</td><td>57</td><td>56</td><td>55</td><td>54</td><td>53</td><td>52</td><td>51</td><td>50</td><td>49</td><td>48</td><td>47</td><td>46</td><td>45</td><td>44</td><td>43</td><td>42</td><td>41</td><td>40</td><td>39</td><td>38</td><td>37</td><td>36</td><td>35</td><td>34</td><td>33</td></tr> <tr><td>96</td><td>95</td><td>94</td><td>93</td><td>92</td><td>91</td><td>90</td><td>89</td><td>88</td><td>87</td><td>86</td><td>85</td><td>84</td><td>83</td><td>82</td><td>81</td><td>80</td><td>79</td><td>78</td><td>77</td><td>76</td><td>75</td><td>74</td><td>73</td><td>72</td><td>71</td><td>70</td><td>69</td><td>68</td><td>67</td><td>66</td><td>65</td></tr> <tr><td>128</td><td>127</td><td>126</td><td>125</td><td>124</td><td>123</td><td>122</td><td>121</td><td>120</td><td>119</td><td>118</td><td>117</td><td>116</td><td>115</td><td>114</td><td>113</td><td>112</td><td>111</td><td>110</td><td>109</td><td>108</td><td>107</td><td>106</td><td>105</td><td>104</td><td>103</td><td>102</td><td>101</td><td>100</td><td>99</td><td>98</td><td>97</td></tr> <tr><td>160</td><td>159</td><td>158</td><td>157</td><td>156</td><td>155</td><td>154</td><td>153</td><td>152</td><td>151</td><td>150</td><td>149</td><td>148</td><td>147</td><td>146</td><td>145</td><td>144</td><td>143</td><td>142</td><td>141</td><td>140</td><td>139</td><td>138</td><td>137</td><td>136</td><td>135</td><td>134</td><td>133</td><td>132</td><td>131</td><td>130</td><td>129</td></tr> <tr><td>192</td><td>191</td><td>190</td><td>189</td><td>188</td><td>187</td><td>186</td><td>185</td><td>184</td><td>183</td><td>182</td><td>181</td><td>180</td><td>179</td><td>178</td><td>177</td><td>176</td><td>175</td><td>174</td><td>173</td><td>172</td><td>171</td><td>170</td><td>169</td><td>168</td><td>167</td><td>166</td><td>165</td><td>164</td><td>163</td><td>162</td><td>161</td></tr> <tr><td>224</td><td>223</td><td>222</td><td>221</td><td>220</td><td>219</td><td>218</td><td>217</td><td>216</td><td>215</td><td>214</td><td>213</td><td>212</td><td>211</td><td>210</td><td>209</td><td>208</td><td>207</td><td>206</td><td>205</td><td>204</td><td>203</td><td>202</td><td>201</td><td>200</td><td>199</td><td>198</td><td>197</td><td>196</td><td>195</td><td>194</td><td>193</td></tr> <tr><td>256</td><td>255</td><td>254</td><td>253</td><td>252</td><td>251</td><td>250</td><td>249</td><td>248</td><td>247</td><td>246</td><td>245</td><td>244</td><td>243</td><td>242</td><td>241</td><td>240</td><td>239</td><td>238</td><td>237</td><td>236</td><td>235</td><td>234</td><td>233</td><td>232</td><td>231</td><td>230</td><td>229</td><td>228</td><td>227</td><td>226</td><td>225</td></tr> <tr><td>288</td><td>287</td><td>286</td><td>285</td><td>284</td><td>283</td><td>282</td><td>281</td><td>280</td><td>279</td><td>278</td><td>277</td><td>276</td><td>275</td><td>274</td><td>273</td><td>272</td><td>271</td><td>270</td><td>269</td><td>268</td><td>267</td><td>266</td><td>265</td><td>264</td><td>263</td><td>262</td><td>261</td><td>260</td><td>259</td><td>258</td><td>257</td></tr> <tr><td>320</td><td>319</td><td>318</td><td>317</td><td>316</td><td>315</td><td>314</td><td>313</td><td>312</td><td>311</td><td>310</td><td>309</td><td>308</td><td>307</td><td>306</td><td>305</td><td>304</td><td>303</td><td>302</td><td>301</td><td>300</td><td>299</td><td>298</td><td>297</td><td>296</td><td>295</td><td>294</td><td>293</td><td>292</td><td>291</td><td>290</td><td>289</td></tr> <tr><td>352</td><td>351</td><td>350</td><td>349</td><td>348</td><td>347</td><td>346</td><td>345</td><td>344</td><td>343</td><td>342</td><td>341</td><td>340</td><td>339</td><td>338</td><td>337</td><td>336</td><td>335</td><td>334</td><td>333</td><td>332</td><td>331</td><td>330</td><td>329</td><td>328</td><td>327</td><td>326</td><td>325</td><td>324</td><td>323</td><td>322</td><td>321</td></tr> <tr><td>384</td><td>383</td><td>382</td><td>381</td><td>380</td><td>379</td><td>378</td><td>377</td><td>376</td><td>375</td><td>374</td><td>373</td><td>372</td><td>371</td><td>370</td><td>369</td><td>368</td><td>367</td><td>366</td><td>365</td><td>364</td><td>363</td><td>362</td><td>361</td><td>360</td><td>359</td><td>358</td><td>357</td><td>356</td><td>355</td><td>354</td><td>353</td></tr> <tr><td>416</td><td>415</td><td>414</td><td>413</td><td>412</td><td>411</td><td>410</td><td>409</td><td>408</td><td>407</td><td>406</td><td>405</td><td>404</td><td>403</td><td>402</td><td>401</td><td>400</td><td>399</td><td>398</td><td>397</td><td>396</td><td>395</td><td>394</td><td>393</td><td>392</td><td>391</td><td>390</td><td>389</td><td>388</td><td>387</td><td>386</td><td>385</td></tr> <tr><td>448</td><td>447</td><td>446</td><td>445</td><td>444</td><td>443</td><td>442</td><td>441</td><td>440</td><td>439</td><td>438</td><td>437</td><td>436</td><td>435</td><td>434</td><td>433</td><td>432</td><td>431</td><td>430</td><td>429</td><td>428</td><td>427</td><td>426</td><td>425</td><td>424</td><td>423</td><td>422</td><td>421</td><td>420</td><td>419</td><td>418</td><td>417</td></tr> <tr><td>480</td><td>479</td><td>478</td><td>477</td><td>476</td><td>475</td><td>474</td><td>473</td><td>472</td><td>471</td><td>470</td><td>469</td><td>468</td><td>467</td><td>466</td><td>465</td><td>464</td><td>463</td><td>462</td><td>461</td><td>460</td><td>459</td><td>458</td><td>457</td><td>456</td><td>455</td><td>454</td><td>453</td><td>452</td><td>451</td><td>450</td><td>449</td></tr> <tr><td>512</td><td>511</td><td>510</td><td>509</td><td>508</td><td>507</td><td>506</td><td>505</td><td>504</td><td>503</td><td>502</td><td>501</td><td>500</td><td>499</td><td>498</td><td>497</td><td>496</td><td>495</td><td>494</td><td>493</td><td>492</td><td>491</td><td>490</td><td>489</td><td>488</td><td>487</td><td>486</td><td>485</td><td>484</td><td>483</td><td>482</td><td>481</td></tr> <tr><td>544</td><td>543</td><td>542</td><td>541</td><td>540</td><td>539</td><td>538</td><td>537</td><td>536</td><td>535</td><td>534</td><td>533</td><td>532</td><td>531</td><td>530</td><td>529</td><td>528</td><td>527</td><td>526</td><td>525</td><td>524</td><td>523</td><td>522</td><td>521</td><td>520</td><td>519</td><td>518</td><td>517</td><td>516</td><td>515</td><td>514</td><td>513</td></tr> <tr><td>576</td><td>575</td><td>574</td><td>573</td><td>572</td><td>571</td><td>570</td><td>569</td><td>568</td><td>567</td><td>566</td><td>565</td><td>564</td><td>563</td><td>562</td><td>561</td><td>560</td><td>559</td><td>558</td><td>557</td><td>556</td><td>555</td><td>554</td><td>553</td><td>552</td><td>551</td><td>550</td><td>549</td><td>548</td><td>547</td><td>546</td><td>545</td></tr> <tr><td>608</td><td>607</td><td>606</td><td>605</td><td>604</td><td>603</td><td>602</td><td>601</td><td>600</td><td>599</td><td>598</td><td>597</td><td>596</td><td>595</td><td>594</td><td>593</td><td>592</td><td>591</td><td>590</td><td>589</td><td>588</td><td>587</td><td>586</td><td>585</td><td>584</td><td>583</td><td>582</td><td>581</td><td>580</td><td>579</td><td>578</td><td>577</td></tr> <tr><td>640</td><td>639</td><td>638</td><td>637</td><td>636</td><td>635</td><td>634</td><td>633</td><td>632</td><td>631</td><td>630</td><td>629</td><td>628</td><td>627</td><td>626</td><td>625</td><td>624</td><td>623</td><td>622</td><td>621</td><td>620</td><td>619</td><td>618</td><td>617</td><td>616</td><td>615</td><td>614</td><td>613</td><td>612</td><td>611</td><td>610</td><td>609</td></tr> <tr><td>672</td><td>671</td><td>670</td><td>669</td><td>668</td><td>667</td><td>666</td><td>665</td><td>664</td><td>663</td><td>662</td><td>661</td><td>660</td><td>659</td><td>658</td><td>657</td><td>656</td><td>655</td><td>654</td><td>653</td><td>652</td><td>651</td><td>650</td><td>649</td><td>648</td><td>647</td><td>646</td><td>645</td><td>644</td><td>643</td><td>642</td><td>641</td></tr> <tr><td>704</td><td>703</td><td>702</td><td>701</td><td>700</td><td>699</td><td>698</td><td>697</td><td>696</td><td>695</td><td>694</td><td>693</td><td>692</td><td>691</td><td>690</td><td>689</td><td>688</td><td>687</td><td>686</td><td>685</td><td>684</td><td>683</td><td>682</td><td>681</td><td>680</td><td>679</td><td>678</td><td>677</td><td>676</td><td>675</td><td>674</td><td>673</td></tr> <tr><td>736</td><td>735</td><td>734</td><td>733</td><td>732</td><td>731</td><td>730</td><td>729</td><td>728</td><td>727</td><td>726</td><td>725</td><td>724</td><td>723</td><td>722</td><td>721</td><td>720</td><td>719</td><td>718</td><td>717</td><td>716</td><td>715</td><td>714</td><td>713</td><td>712</td><td>711</td><td>710</td><td>709</td><td>708</td><td>707</td><td>706</td><td>705</td></tr> <tr><td>768</td><td>767</td><td>766</td><td>765</td><td>764</td><td>763</td><td>762</td><td>761</td><td>760</td><td>759</td><td>758</td><td>757</td><td>756</td><td>755</td><td>754</td><td>753</td><td>752</td><td>751</td><td>750</td><td>749</td><td>748</td><td>747</td><td>746</td><td>745</td><td>744</td><td>743</td><td>742</td><td>741</td><td>740</td><td>739</td><td>738</td><td>737</td></tr> </table>	32	31	30	29	28	27	26	25	24	23	22	21	20	19	18	17	16	15	14	13	12	11	10	9	8	7	6	5	4	3	2	1	64	63	62	61	60	59	58	57	56	55	54	53	52	51	50	49	48	47	46	45	44	43	42	41	40	39	38	37	36	35	34	33	96	95	94	93	92	91	90	89	88	87	86	85	84	83	82	81	80	79	78	77	76	75	74	73	72	71	70	69	68	67	66	65	128	127	126	125	124	123	122	121	120	119	118	117	116	115	114	113	112	111	110	109	108	107	106	105	104	103	102	101	100	99	98	97	160	159	158	157	156	155	154	153	152	151	150	149	148	147	146	145	144	143	142	141	140	139	138	137	136	135	134	133	132	131	130	129	192	191	190	189	188	187	186	185	184	183	182	181	180	179	178	177	176	175	174	173	172	171	170	169	168	167	166	165	164	163	162	161	224	223	222	221	220	219	218	217	216	215	214	213	212	211	210	209	208	207	206	205	204	203	202	201	200	199	198	197	196	195	194	193	256	255	254	253	252	251	250	249	248	247	246	245	244	243	242	241	240	239	238	237	236	235	234	233	232	231	230	229	228	227	226	225	288	287	286	285	284	283	282	281	280	279	278	277	276	275	274	273	272	271	270	269	268	267	266	265	264	263	262	261	260	259	258	257	320	319	318	317	316	315	314	313	312	311	310	309	308	307	306	305	304	303	302	301	300	299	298	297	296	295	294	293	292	291	290	289	352	351	350	349	348	347	346	345	344	343	342	341	340	339	338	337	336	335	334	333	332	331	330	329	328	327	326	325	324	323	322	321	384	383	382	381	380	379	378	377	376	375	374	373	372	371	370	369	368	367	366	365	364	363	362	361	360	359	358	357	356	355	354	353	416	415	414	413	412	411	410	409	408	407	406	405	404	403	402	401	400	399	398	397	396	395	394	393	392	391	390	389	388	387	386	385	448	447	446	445	444	443	442	441	440	439	438	437	436	435	434	433	432	431	430	429	428	427	426	425	424	423	422	421	420	419	418	417	480	479	478	477	476	475	474	473	472	471	470	469	468	467	466	465	464	463	462	461	460	459	458	457	456	455	454	453	452	451	450	449	512	511	510	509	508	507	506	505	504	503	502	501	500	499	498	497	496	495	494	493	492	491	490	489	488	487	486	485	484	483	482	481	544	543	542	541	540	539	538	537	536	535	534	533	532	531	530	529	528	527	526	525	524	523	522	521	520	519	518	517	516	515	514	513	576	575	574	573	572	571	570	569	568	567	566	565	564	563	562	561	560	559	558	557	556	555	554	553	552	551	550	549	548	547	546	545	608	607	606	605	604	603	602	601	600	599	598	597	596	595	594	593	592	591	590	589	588	587	586	585	584	583	582	581	580	579	578	577	640	639	638	637	636	635	634	633	632	631	630	629	628	627	626	625	624	623	622	621	620	619	618	617	616	615	614	613	612	611	610	609	672	671	670	669	668	667	666	665	664	663	662	661	660	659	658	657	656	655	654	653	652	651	650	649	648	647	646	645	644	643	642	641	704	703	702	701	700	699	698	697	696	695	694	693	692	691	690	689	688	687	686	685	684	683	682	681	680	679	678	677	676	675	674	673	736	735	734	733	732	731	730	729	728	727	726	725	724	723	722	721	720	719	718	717	716	715	714	713	712	711	710	709	708	707	706	705	768	767	766	765	764	763	762	761	760	759	758	757	756	755	754	753	752	751	750	749	748	747	746	745	744	743	742	741	740	739	738	737
32	31	30	29	28	27	26	25	24	23	22	21	20	19	18	17	16	15	14	13	12	11	10	9	8	7	6	5	4	3	2	1																																																																																																																																																																																																																																																																																																																																																																																																																																																																																																																																																																																																																																																																																																																																																																			
64	63	62	61	60	59	58	57	56	55	54	53	52	51	50	49	48	47	46	45	44	43	42	41	40	39	38	37	36	35	34	33																																																																																																																																																																																																																																																																																																																																																																																																																																																																																																																																																																																																																																																																																																																																																																			
96	95	94	93	92	91	90	89	88	87	86	85	84	83	82	81	80	79	78	77	76	75	74	73	72	71	70	69	68	67	66	65																																																																																																																																																																																																																																																																																																																																																																																																																																																																																																																																																																																																																																																																																																																																																																			
128	127	126	125	124	123	122	121	120	119	118	117	116	115	114	113	112	111	110	109	108	107	106	105	104	103	102	101	100	99	98	97																																																																																																																																																																																																																																																																																																																																																																																																																																																																																																																																																																																																																																																																																																																																																																			
160	159	158	157	156	155	154	153	152	151	150	149	148	147	146	145	144	143	142	141	140	139	138	137	136	135	134	133	132	131	130	129																																																																																																																																																																																																																																																																																																																																																																																																																																																																																																																																																																																																																																																																																																																																																																			
192	191	190	189	188	187	186	185	184	183	182	181	180	179	178	177	176	175	174	173	172	171	170	169	168	167	166	165	164	163	162	161																																																																																																																																																																																																																																																																																																																																																																																																																																																																																																																																																																																																																																																																																																																																																																			
224	223	222	221	220	219	218	217	216	215	214	213	212	211	210	209	208	207	206	205	204	203	202	201	200	199	198	197	196	195	194	193																																																																																																																																																																																																																																																																																																																																																																																																																																																																																																																																																																																																																																																																																																																																																																			
256	255	254	253	252	251	250	249	248	247	246	245	244	243	242	241	240	239	238	237	236	235	234	233	232	231	230	229	228	227	226	225																																																																																																																																																																																																																																																																																																																																																																																																																																																																																																																																																																																																																																																																																																																																																																			
288	287	286	285	284	283	282	281	280	279	278	277	276	275	274	273	272	271	270	269	268	267	266	265	264	263	262	261	260	259	258	257																																																																																																																																																																																																																																																																																																																																																																																																																																																																																																																																																																																																																																																																																																																																																																			
320	319	318	317	316	315	314	313	312	311	310	309	308	307	306	305	304	303	302	301	300	299	298	297	296	295	294	293	292	291	290	289																																																																																																																																																																																																																																																																																																																																																																																																																																																																																																																																																																																																																																																																																																																																																																			
352	351	350	349	348	347	346	345	344	343	342	341	340	339	338	337	336	335	334	333	332	331	330	329	328	327	326	325	324	323	322	321																																																																																																																																																																																																																																																																																																																																																																																																																																																																																																																																																																																																																																																																																																																																																																			
384	383	382	381	380	379	378	377	376	375	374	373	372	371	370	369	368	367	366	365	364	363	362	361	360	359	358	357	356	355	354	353																																																																																																																																																																																																																																																																																																																																																																																																																																																																																																																																																																																																																																																																																																																																																																			
416	415	414	413	412	411	410	409	408	407	406	405	404	403	402	401	400	399	398	397	396	395	394	393	392	391	390	389	388	387	386	385																																																																																																																																																																																																																																																																																																																																																																																																																																																																																																																																																																																																																																																																																																																																																																			
448	447	446	445	444	443	442	441	440	439	438	437	436	435	434	433	432	431	430	429	428	427	426	425	424	423	422	421	420	419	418	417																																																																																																																																																																																																																																																																																																																																																																																																																																																																																																																																																																																																																																																																																																																																																																			
480	479	478	477	476	475	474	473	472	471	470	469	468	467	466	465	464	463	462	461	460	459	458	457	456	455	454	453	452	451	450	449																																																																																																																																																																																																																																																																																																																																																																																																																																																																																																																																																																																																																																																																																																																																																																			
512	511	510	509	508	507	506	505	504	503	502	501	500	499	498	497	496	495	494	493	492	491	490	489	488	487	486	485	484	483	482	481																																																																																																																																																																																																																																																																																																																																																																																																																																																																																																																																																																																																																																																																																																																																																																			
544	543	542	541	540	539	538	537	536	535	534	533	532	531	530	529	528	527	526	525	524	523	522	521	520	519	518	517	516	515	514	513																																																																																																																																																																																																																																																																																																																																																																																																																																																																																																																																																																																																																																																																																																																																																																			
576	575	574	573	572	571	570	569	568	567	566	565	564	563	562	561	560	559	558	557	556	555	554	553	552	551	550	549	548	547	546	545																																																																																																																																																																																																																																																																																																																																																																																																																																																																																																																																																																																																																																																																																																																																																																			
608	607	606	605	604	603	602	601	600	599	598	597	596	595	594	593	592	591	590	589	588	587	586	585	584	583	582	581	580	579	578	577																																																																																																																																																																																																																																																																																																																																																																																																																																																																																																																																																																																																																																																																																																																																																																			
640	639	638	637	636	635	634	633	632	631	630	629	628	627	626	625	624	623	622	621	620	619	618	617	616	615	614	613	612	611	610	609																																																																																																																																																																																																																																																																																																																																																																																																																																																																																																																																																																																																																																																																																																																																																																			
672	671	670	669	668	667	666	665	664	663	662	661	660	659	658	657	656	655	654	653	652	651	650	649	648	647	646	645	644	643	642	641																																																																																																																																																																																																																																																																																																																																																																																																																																																																																																																																																																																																																																																																																																																																																																			
704	703	702	701	700	699	698	697	696	695	694	693	692	691	690	689	688	687	686	685	684	683	682	681	680	679	678	677	676	675	674	673																																																																																																																																																																																																																																																																																																																																																																																																																																																																																																																																																																																																																																																																																																																																																																			
736	735	734	733	732	731	730	729	728	727	726	725	724	723	722	721	720	719	718	717	716	715	714	713	712	711	710	709	708	707	706	705																																																																																																																																																																																																																																																																																																																																																																																																																																																																																																																																																																																																																																																																																																																																																																			
768	767	766	765	764	763	762	761	760	759	758	757	756	755	754	753	752	751	750	749	748	747	746	745	744	743	742	741	740	739	738	737																																																																																																																																																																																																																																																																																																																																																																																																																																																																																																																																																																																																																																																																																																																																																																			

Model	Pixel	Illustration
iSN-813-MTCP	80 x 60 = 4800	

■ Area Segmentation and Management

To enhance temperature monitoring efficiency, the iSN-81x series products divide the overall sensing area into multiple smaller areas based on sensor resolution. Each area can independently calculate and display key parameters, including: maximum temperature, minimum temperature, average temperature, warning threshold, and danger threshold. Through area-based management, users can more accurately track localized temperature variations and configure corresponding alarms or protective mechanisms for abnormal areas, effectively improving system responsiveness and overall monitoring reliability.

■ iSN-811 series

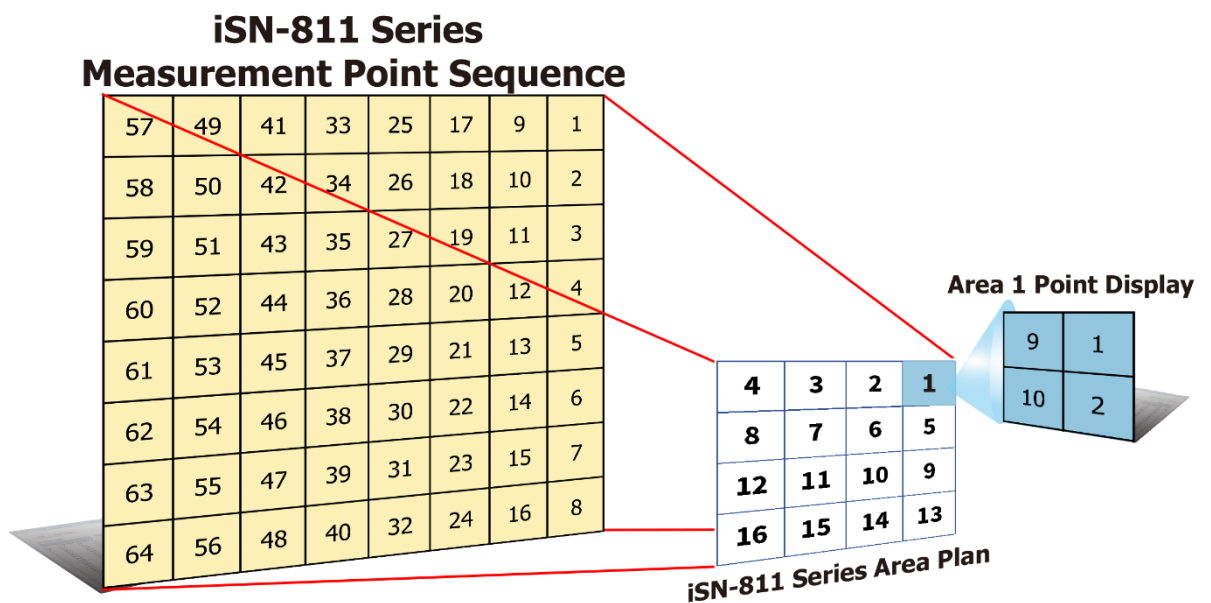

■ iSN-812 series

iSN-812 Series Measurement Point Sequence

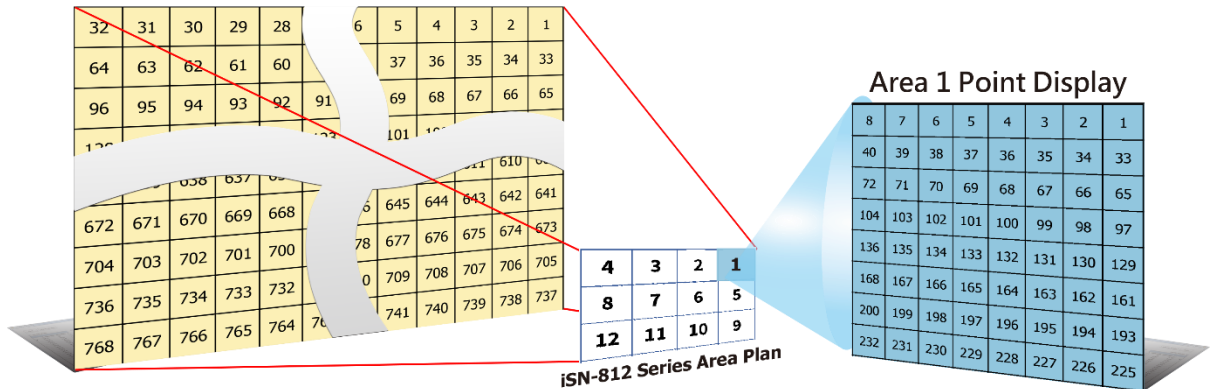

■ iSN-813 series

iSN-811 Series Measurement Point Sequence

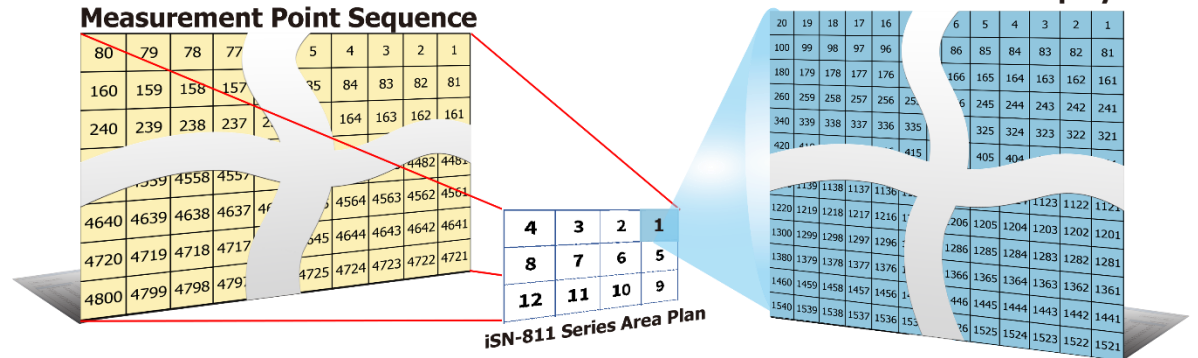

■ **Evaluating Measurement Coverage Using FOV**

The iSN-81x series offers a variety of Field of View (FOV) options to ensure stable coverage of target areas under different installation heights and angles. The FOV parameter determines the spatial area and resolution density the sensor can monitor, which directly affects the granularity of area segmentation and the accuracy of interpreting temperature distribution. Users can select the most suitable installation position based on application requirements to achieve optimal detection performance and area coverage.

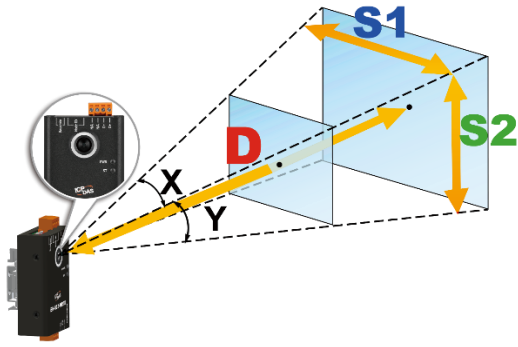

Label	Description	Label	Description
X	X-axis viewing angle	D	Distance between the module lens and the target object
Y	Y-axis viewing angle	S1	Horizontal width of the field of view
		S2	Vertical height of the field of view

■ Supports Multiple Communication Protocols

Depending on the product series, supports Modbus RTU / Modbus TCP / RESTful / MQTT, making it easy for users to integrate with various SCADA systems and software development platforms.

Protocol	iSN-81x-MRTU	iSN-81x-MTCP	Data type
Modbus RTU	√	X	Raw Data, Regional Features, Threshold Values, Diagnostic Messages
Modbus TCP	X	√	
RESTful	X	√	Raw Data
MQTT	X	√	

■ Free Module Configuration and Status Monitoring Software

The iSN-81x series provides dedicated tools for different communication protocols: a utility software for MRTU and a web-based configuration interface for MTCP. These tools are used for device setup and data analysis. Users can monitor on-site temperature distribution through real-time thermal imaging and trend graphs. Sample programs are also provided to facilitate user development and application integration.

■ Temperature Threshold Detection Function

The system supports dual-level threshold settings, categorized as Warning Threshold and Danger Threshold. Each segmented area can be individually configured with a set of warning parameters, including threshold switch, upper and lower limits for the warning threshold, and upper and lower limits for the danger threshold.

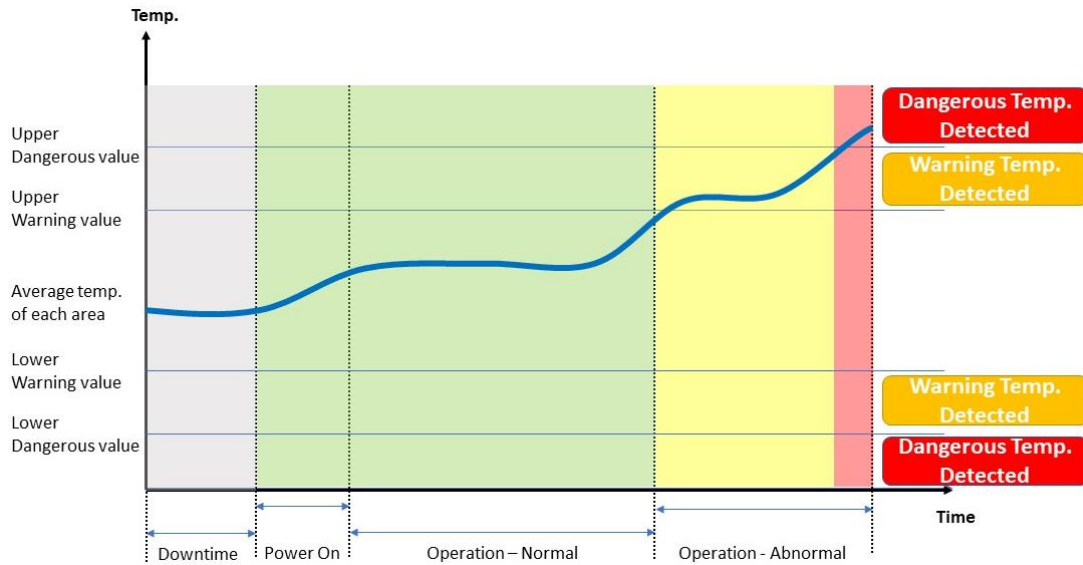

iSN-81xC-MTCP Integrates Thermal Imaging and Live Video

The iSN-81xC-MTCP is an infrared temperature sensing module equipped with a built-in camera, capable of integrating thermal imaging with live visual footage to provide more intuitive temperature monitoring and analysis.

This module can overlay infrared thermal images with visible images of the target, allowing personnel to quickly assess equipment temperature distribution in real time. Through the web interface, it provides thermal images and temperature trend graphs to support rapid decision-making.

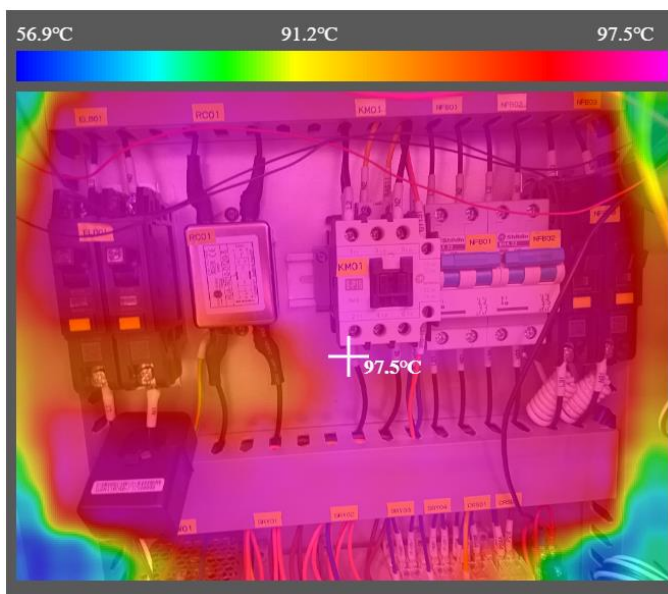

2 Hardware information

2.1 Specifications

Model	iSN-812-MRTU	iSN-811C-MTCP	iSN-812-MTCP	iSN-813-MTCP
Communication Ports				
Ports	1 x RS-485	Ethernet, IEEE 802.3af, Class 1		
Protocol	Modbus RTU	Modbus TCP / MQTT / RESTful		
Temperature Measurement				
Range	-40°C~300°C	-20°C~250°C	-40°C~300°C	-20°C~300°C
Accuracy	±5°C Max			
Resolution	0.1°C			
Distance	≤2m	≤1m	≤2m	≤6m
Pixel	768 (32x24)	64 (8x8)	768 (32x24)	4800(80x60)
FOV	X: 110° / D : S1 =1 : 2.86 Y:75° / D : S2 =1 : 1.53	X: 60° / D : S1 =1 : 1.15 Y: 60° / D : S2 =1 : 1.15	X: 110° / D : S1 =1 : 2.86 Y:75° / D : S2 =1 : 1.53	X: 90° / D : S1 =1 : 2 Y: 67° / D : S2 =1 : 1.32
Motion picture (camera)				
Pixels	-	QVGA (320 x 240)	-	-
Fill light	-	Yes	-	-
Power				
Input Range	+10~+30VDC			
Consumption	0.9W	1.2W	0.6W	1W
Mechanical				
Installation	Din-rail or magnetic(Optional), universal joint(Optional)			
Dimensions (mm) (W x H x D)	52 x 94 x 33	52 x 86 x 34	52 x 86 x 33	
Environment				
Operating Temperature	-10°C ~+70°C			
Storage Temperature	-20°C ~+80°C			
Humidity	10~95% RH, Non-condensing			

2.2 Appearance (Wiring, DIP Switch, LED Status)

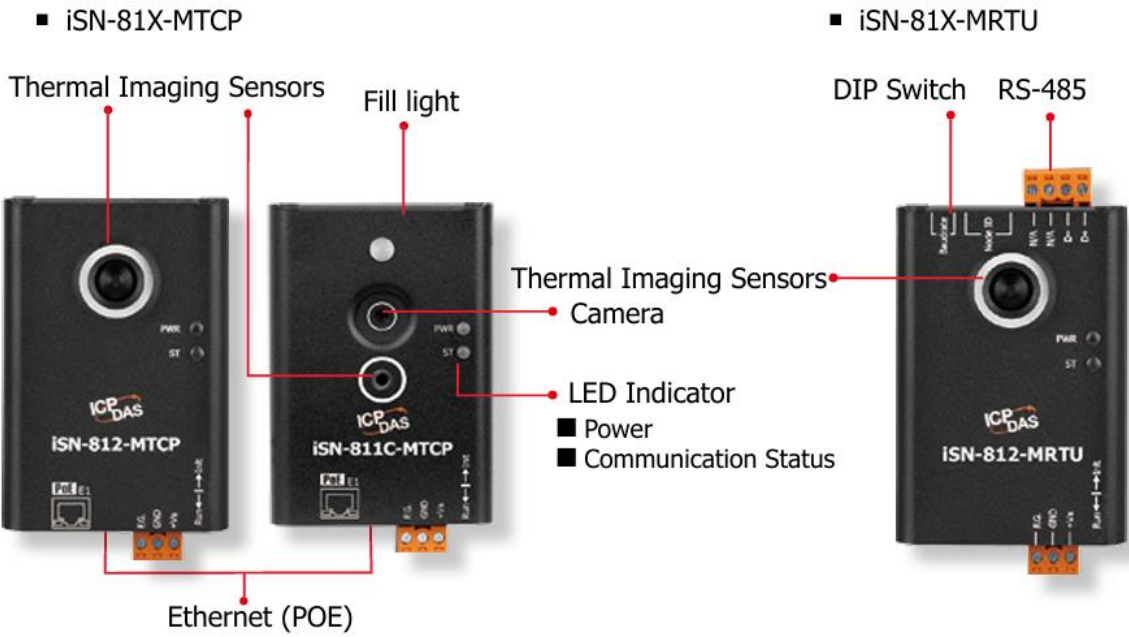

■ iSN-81x-MTCP Supports PoE (Power over Ethernet)

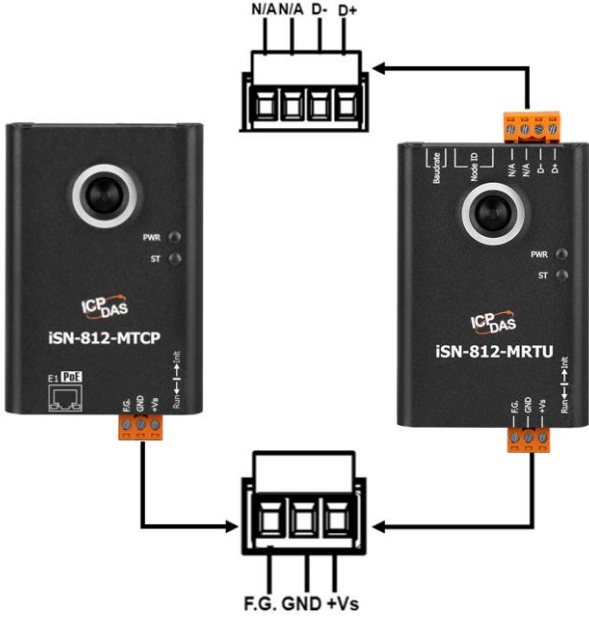

PoE (Power over Ethernet) provides a flexible power supply option. It supports IEEE 802.3af Class 1 PoE, allowing both power and data transmission via a PoE switch, reducing additional wiring costs. In non-PoE network environments, the module can also be powered through a DC power input (+10 V to +30 V DC).

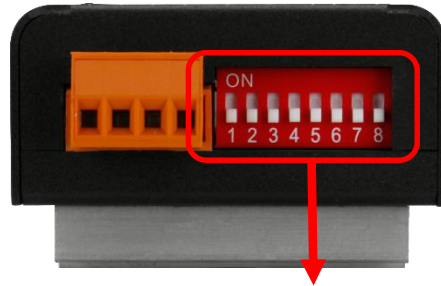

DIP Switch

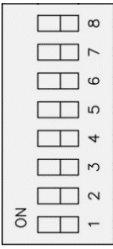

DIP Switch

Switch	Pin Number	Function	Example																													
 <p>*1</p>	1~5	Modbus ID (ID range: 1~31)	<table border="1"> <thead> <tr> <th rowspan="2">ID</th> <th colspan="5">Switch</th> </tr> <tr> <th>1→2⁰</th> <th>2→2¹</th> <th>3→2²</th> <th>4→2³</th> <th>5→2⁴</th> </tr> </thead> <tbody> <tr> <td>1</td> <td>1</td> <td>0</td> <td>0</td> <td>0</td> <td>0</td> </tr> <tr> <td>10</td> <td>0</td> <td>1</td> <td>0</td> <td>1</td> <td>0</td> </tr> <tr> <td>30</td> <td>0</td> <td>1</td> <td>1</td> <td>1</td> <td>1</td> </tr> </tbody> </table> <p>Note : 1→ON · 0→OFF</p>	ID	Switch					1→2 ⁰	2→2 ¹	3→2 ²	4→2 ³	5→2 ⁴	1	1	0	0	0	0	10	0	1	0	1	0	30	0	1	1	1	1
	ID	Switch																														
1→2 ⁰		2→2 ¹	3→2 ²	4→2 ³	5→2 ⁴																											
1	1	0	0	0	0																											
10	0	1	0	1	0																											
30	0	1	1	1	1																											
	6~8	Baudrate *2	<table border="1"> <thead> <tr> <th rowspan="2">Baudrate (bps)</th> <th colspan="3">Switch</th> </tr> <tr> <th>6</th> <th>7</th> <th>8</th> </tr> </thead> <tbody> <tr> <td>9600</td> <td>0</td> <td>0</td> <td>0</td> </tr> <tr> <td>19200</td> <td>1</td> <td>0</td> <td>0</td> </tr> <tr> <td>38400</td> <td>0</td> <td>1</td> <td>0</td> </tr> <tr> <td>57600</td> <td>1</td> <td>1</td> <td>0</td> </tr> <tr> <td>115200</td> <td>0</td> <td>0</td> <td>1</td> </tr> </tbody> </table> <p>Note: 1=>ON, 0=>OFF</p>	Baudrate (bps)	Switch			6	7	8	9600	0	0	0	19200	1	0	0	38400	0	1	0	57600	1	1	0	115200	0	0	1		
Baudrate (bps)	Switch																															
	6	7	8																													
9600	0	0	0																													
19200	1	0	0																													
38400	0	1	0																													
57600	1	1	0																													
115200	0	0	1																													
 <p>Init Run</p>		Init	Device works in waiting to be upload Firmware mode.																													
		Run	Device works in normal mode.																													

*1. Only for iSN-81x-MRTU Series.

*2. The Data format of COM Port: None Parity, 8 Data bit, 1 Stop bit. (N,8,1).

LED Indicators



LED Status		Description
PWR	ST	
ON	OFF	Power supply is OK and waiting for connection.
ON	ON	The connection established but transmission not yet started.
Flash (0.05 sec)	ON	Thermal data transmission (only for MTCP series)
Flash (0.05 sec)	Flash (0.5 sec)	Thermal data transmission with abnormal temperature judgment (only for MTCP series).
ON	Flash (0.5 sec)	Abnormal temperature judgment.
Flash (0.5 sec)	Flash (0.5 sec)	eSearch Locate (only for MTCP series).

2.3 Dimensions

iSN-811C-MTCP

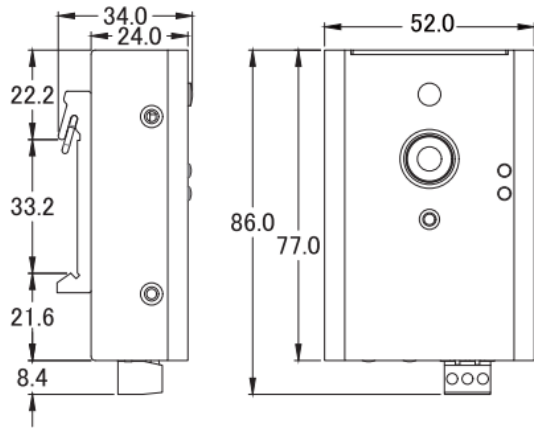

iSN-812-MRTU

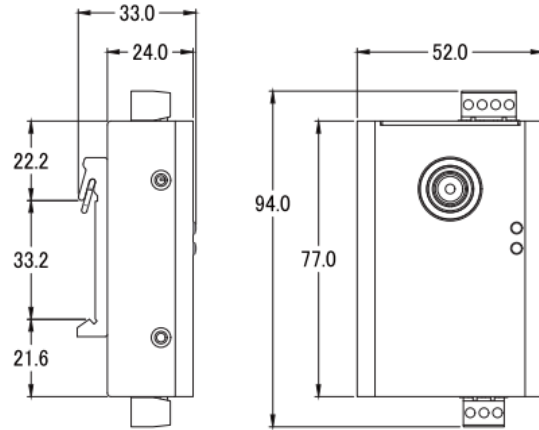

iSN-812-MTCP

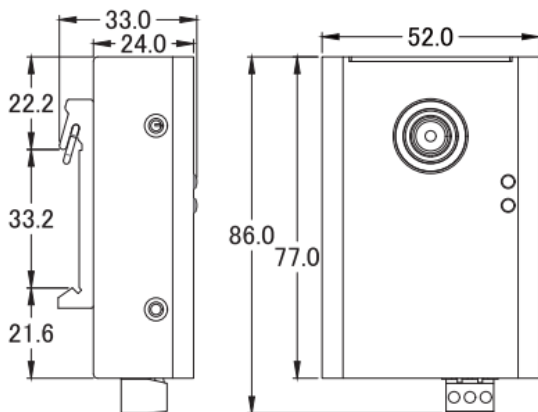

iSN-813-MTCP

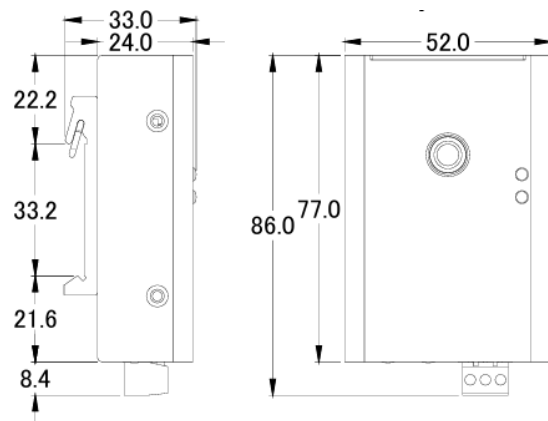

Unit : (mm)

2.4 Accessories

ASO-0054 CR	ASO-0060 CR	WM01-M CR
 <p>Universal Joint Bracket(RoHS)</p>	 <p>Magnetic Base Universal Joint Bracket(RoHS)</p>	 <p>44 mm Magnetic Mounting Kit(RoHS)</p>

2.5 Installation

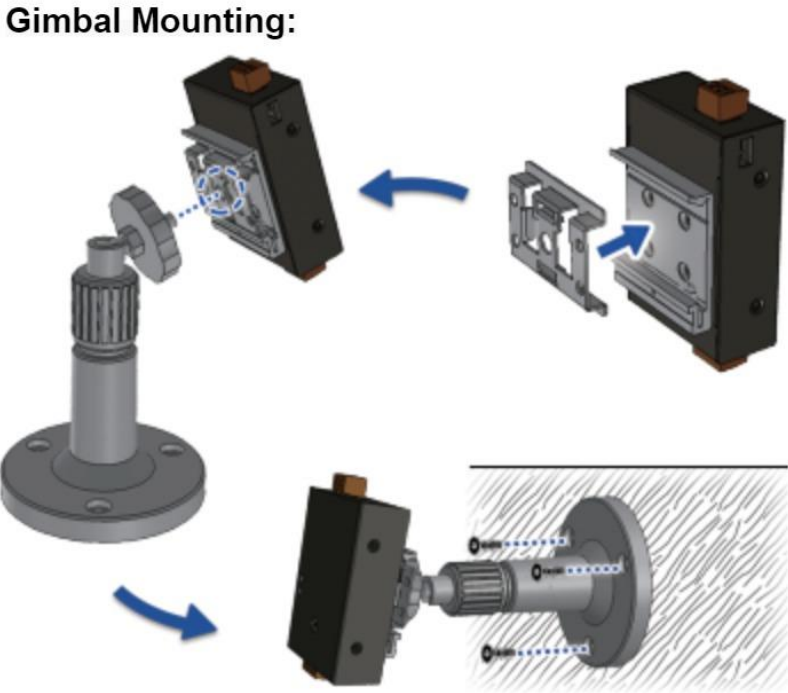
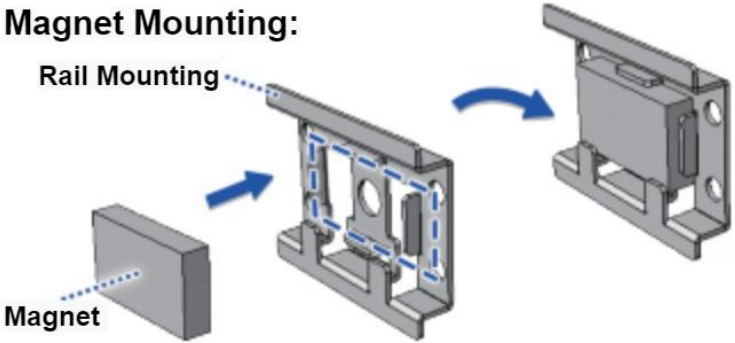
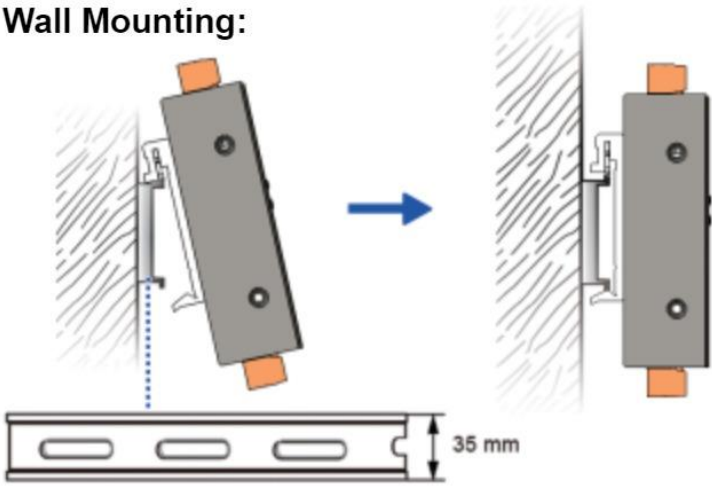

3 iSN-81x-MRTU Configuration and Monitoring (Utility Software)

The iSN-8xx_Tool Utility is a dedicated software tool for iSN-81x-MRTU. The LiveList Utility can quickly search for iSN-81x-MRTU devices, while the IR_Configuration Utility can read temperature data from iSN-81x-MRTU, display it as a thermal image, and record temperature data over a period of time, among other functions.

Click the link below to download the iSN_8xx_Tool software:

<https://www.icpdas.com/tw/download/show.php?num=6650&model=iSN-812-MRTU>

After downloading and extracting the software package, the following files will be available:





Find Online Devices	LiveList.exe
Configuration, Monitoring, and Alarming	IR_Configuration.exe
Required Files	log4ent.dll / nmodbuspc.dll / locomp.Instrumentation.WF2005.Plot.dll / locomp.Instrumentation.WF2005.Common.dll

3.1 LiveList.exe : Find Online Devices

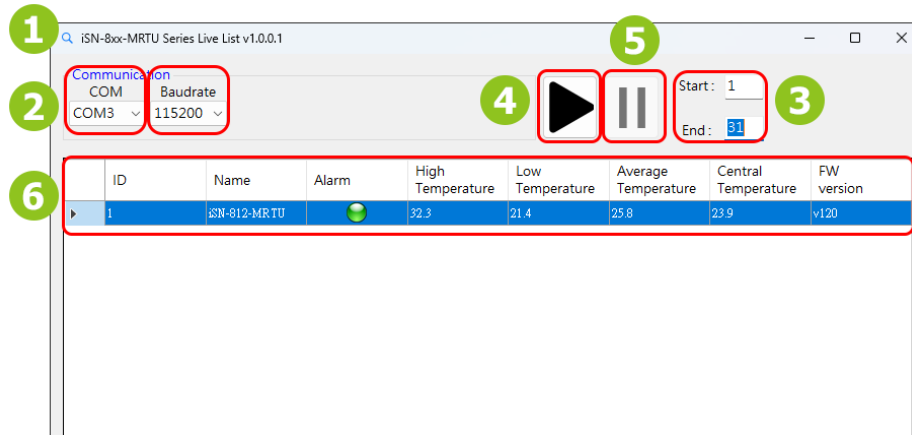
The LiveList.exe utility can search for connected iSN-81x-MRTU devices. When searching for multiple devices, ensure that the devices are connected to the same bus network, have the same communication baud rate, and each has a unique, non-conflicting device ID. The search steps are as follows:

1. Open LiveList.exe to search for iSN-81x-MRTU devices: Displays their connection status and basic information.



2. Set the communication parameters of the serial port.
 - COM : Set COM Port.
 - Baudrate : Set Baudrate.
3. Set the device ID search range: Define the device ID range to be searched; the software will search for and identify devices within the specified range.
 - Start : Start address of the device ID search (e.g., 1).
 - End : End address of the device ID search (e.g., 31; the maximum value for iSN-81x-MRTU can be set to 31).
4. Click  Start Searching for Online Modules: The system will automatically scan for devices within the configured range.
5. If the target device is found, you can click  Stop Searching for Modules.
6. Results Display: When an iSN-81x-MRTU module is found, its status will be shown in the list below. Double-click to configure this module. Each column in the list is explained below:
 - ID : Modbus ID of iSN-81x-MRTU.
 - Name : Model of iSN-81x-MRTU.
 - Alarm :  No diagnostic message \  iSN-81x-MRTU has diagnostic message.
 - High Temperature : The highest temperature of iSN-81x-MRTU.
 - Low Temperature : The lowest temperature of iSN-81x-MRTU.
 - Average Temperature : The average temperature of iSN-81x-MRTU.
 - Central Temperature : The central temperature of iSN-81x-MRTU.
 - FW version : FW version of iSN-81x-MRTU.

3.2 IR_Configuraion.exe : Configuration, Monitoring, and Diagnostics

Open the IR_Configuration.exe software. At the top, there are three functional tabs: Thermal Image & Area Status, Temperature Data Logging, and Communication Settings. For detailed settings and functions, please refer to the following sections.

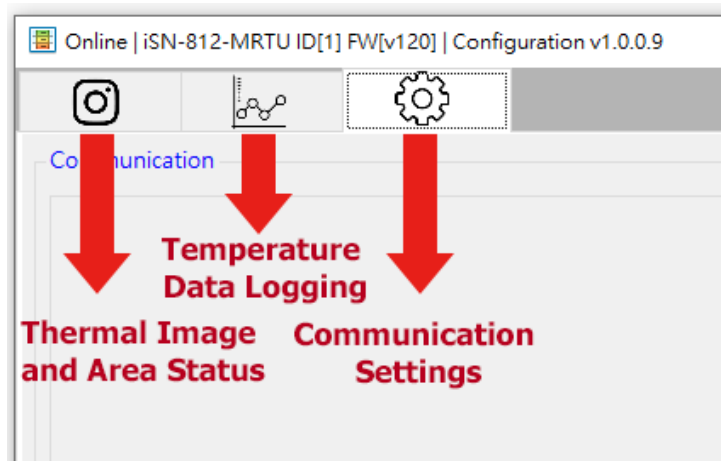

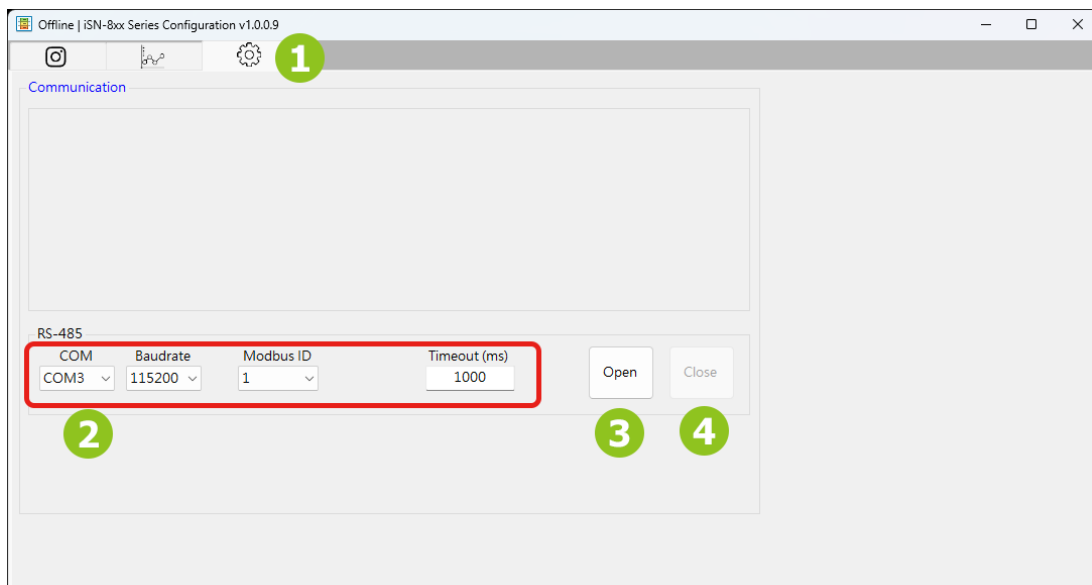

3.2.1 Connecting to the iSN-81x-MRTU Module

Open the IR_Configuration.exe software, and connect to the device based on the search results shown in the "Find Online Devices" function. Once connected, you can configure relevant parameters, monitor real-time communication status, and view related diagnostic messages.







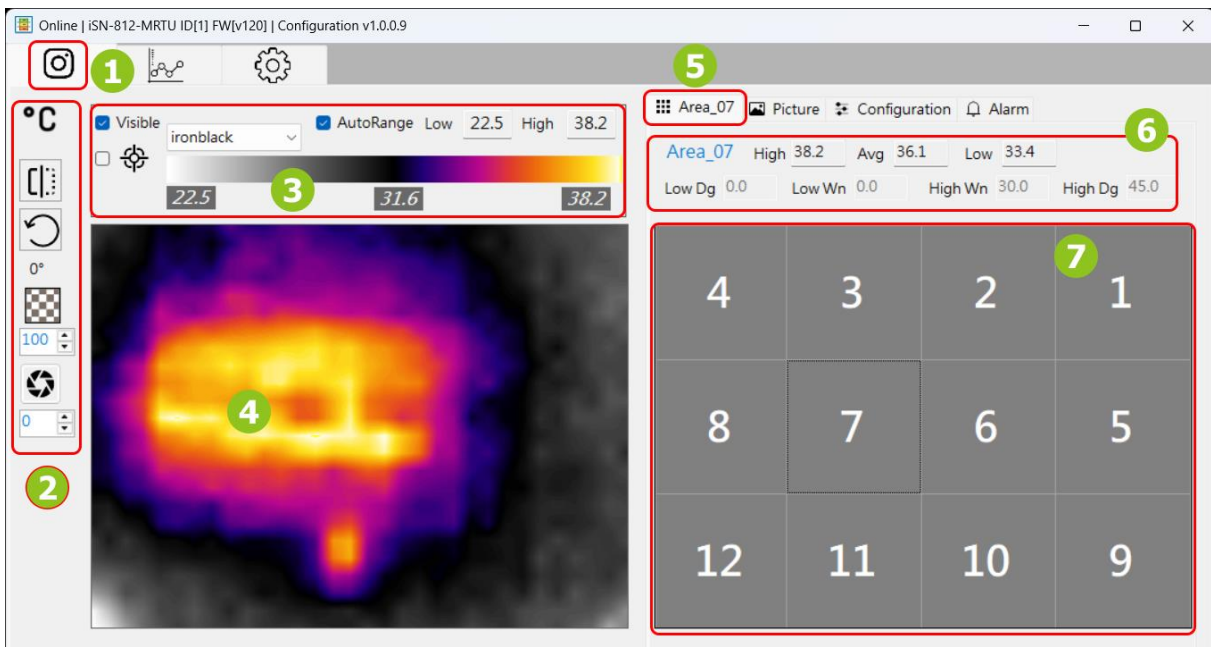

1. After launching the software, click  to enter the connection settings screen.

2. RS-485 Serial port setting :
 - COM : Set the communication port connected to the iSN-81x-MRTU.
 - Baudrate : Set the communication baud rate connected to the iSN-81x-MRTU.
 - Modbus ID : Set the device ID of the iSN-81x-MRTU to connect (refer to Section 3.1 search results).
 - Timeout (ms) : Set the communication timeout duration for the device, in milliseconds (ms).
3.  Start Connection: Establish the device connection based on the serial port settings.
4.  Close Connection: Terminate the device connection.

3.2.2 Thermal Image & Area Status

This section introduces the operation interface and functional configuration of the thermal image monitoring system, explaining how to use infrared thermal imaging technology to monitor the temperature distribution of equipment or areas in real time. The content covers image display and adjustment, temperature threshold settings, real-time status display of each area, as well as automatic saving and color scale control functions.



1.  **Module Thermal Image Configuration:** Click the Module Thermal Image Settings tab to open the real-time thermal image monitoring interface. The software interface includes functions such as real-time thermal imaging, thermal image display settings, and real-time area status and area parameter settings. The thermal image uses infrared technology to detect the temperature distribution of objects, which is displayed in the image with different colors or brightness levels to help identify heat sources, abnormal temperature areas, or potential failure points. The area status is based on the temperature condition within the segmented area and provides information such as area status, average area temperature, maximum area temperature, minimum area temperature, and more.
2. **Drawing Tool Column:**
 -  **Temperature Unit:** For the configuration method, please refer to Section 3.2.4.
 -  **Thermal Image Mirroring:** Refers to processing the image obtained through thermal imaging technology with horizontal mirroring (flipping or reflecting) in specific scenarios.
 -  **Thermal Image Rotation:** Refers to rotating the thermal image to adapt to different analysis requirements or perspective adjustments, with each rotation being 90 degrees clockwise.
 -  **Adjust Thermal Image Transparency:** Adjusting the transparency of the thermal image is an image processing technique mainly used to improve visualization effects, enabling the thermal image to be overlaid with other images (such as visible light photos or equipment diagrams) for a more intuitive analysis of temperature distribution and background information.
 -  **Save Thermal Image:** Saves the captured thermal imaging image to ensure it can be used for subsequent analysis, sharing, or archiving. The storage location is under the Thermal Image directory.

-  Automatic Thermal Image Save Interval (seconds): Refers to the time interval set for the thermal imaging device or software system when continuously recording images.

3. Thermal Image Settings:

- Visible** Display Thermal Image: "Visible" is used to set whether the thermal image should be displayed. If unchecked, only the background image will be shown.

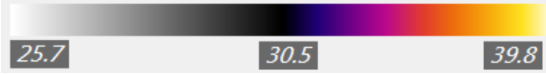
-  Thermal Image Color Scale Range:

The color scale range of the thermal image usually represents the temperature distribution, showing detected temperatures in different colors.

- AutoRange Auto Adjust Color Scale Range: If unchecked, you can manually set the High (maximum temperature) and Low (minimum temperature) within the color scale.

-  Set Maximum Temperature Marker: Setting the maximum temperature marker helps identify the highest temperature point in the image, commonly used for monitoring high-temperature anomalies, fault diagnosis, or safety inspections.

- Palette:** Provides color scale options, allowing users to interpret thermal images more clearly.

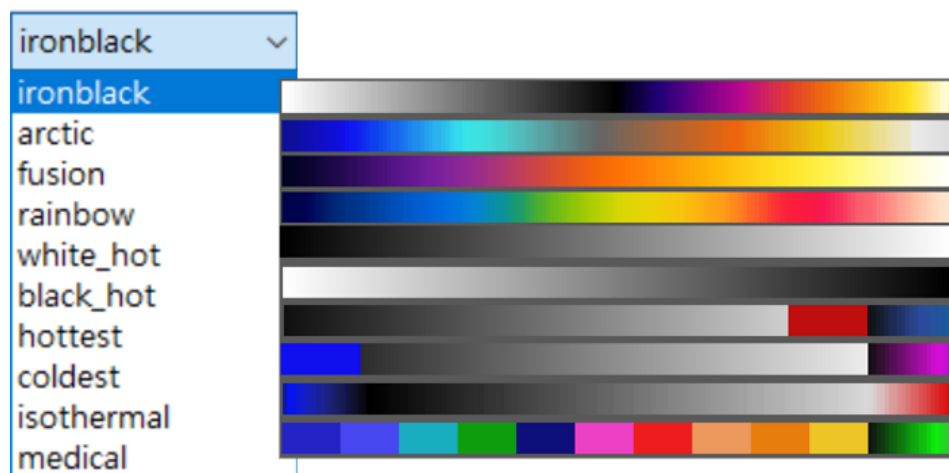

- Real-time Thermal Image Display Area.
- Selected Area Number Indicator.
- Real-time Status Data Displayed Based on the Selected Area:
 - High :** Maximum temperature in the area.



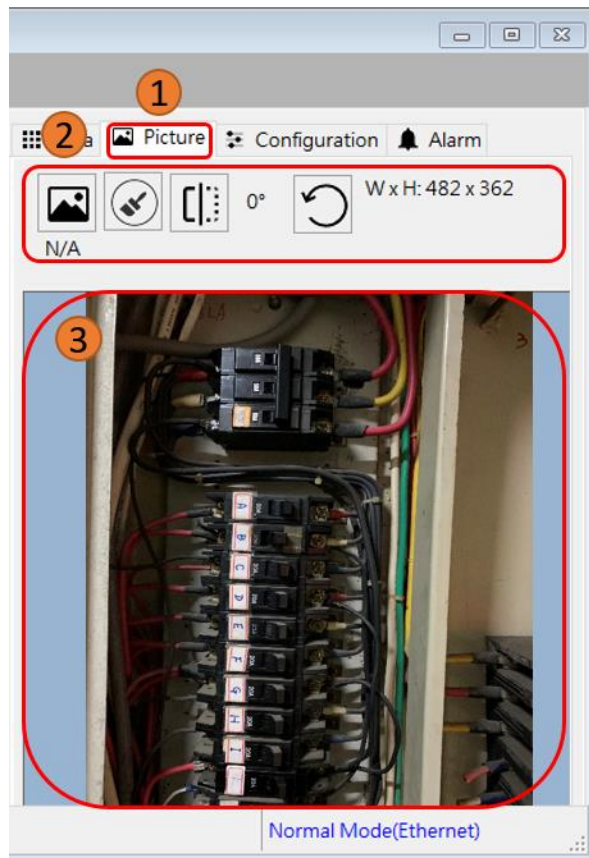

- Low : Minimum temperature in the area.
 - Avg : Average temperature in the area.
 - Low Dg : Danger threshold lower limit set for the area.
 - Low Wn : Warning threshold lower limit set for the area.
 - High Wn : Warning threshold upper limit set for the area.
 - High Dg : Danger threshold upper limit set for the area.
7. Display Status of Each Area:
- Gray : Threshold switch is not turned on.
 - Red : The area temperature is higher (or lower) than the danger value.
 - Yellow : The area temperature is higher (or lower) than the warning value.
 - Green : The area temperature is normal.

3.2.3 Import image

The image import function allows you to import external images into the application to help better understand the actual on-site conditions.



1. In the IR_Configuration.exe program, under the Thermal Image & Area Status section, go to the Picture tab.
2. Background Image Toolbar:

-  Import Image: Allows importing an image for temperature analysis and visual assessment.
 -  Remove Image: Deletes or hides the image to clear the workspace or replace it with a new one.
 -  Mirror Background Image: Mirrors the background image horizontally for symmetrical display.
 -  Rotate Background Image: Rotates the imported background image clockwise by 90 degrees to accommodate different on-site installation angles.
3. The imported background image will be displayed in the viewing window according to the settings, showing the output result.





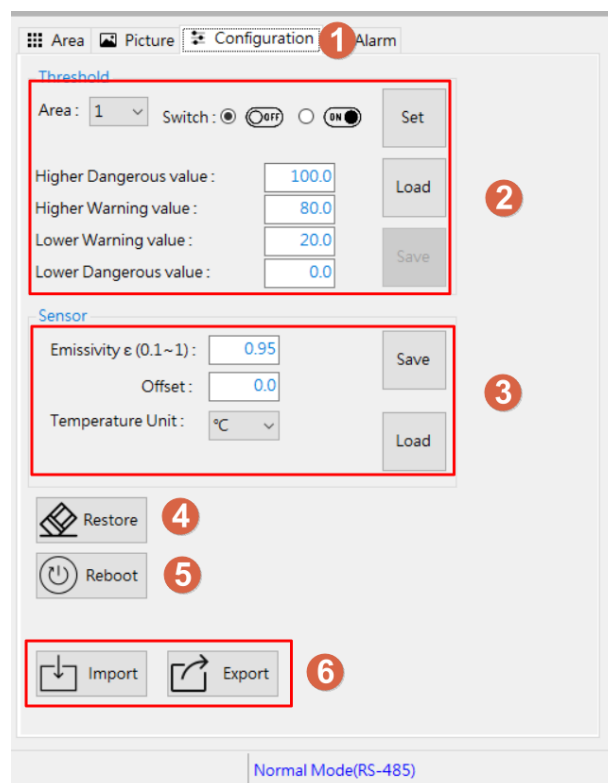

3.2.4 Parameter Settings

The Configuration page is mainly used for setting area thresholds, iSN-81x-MRTU module measurement parameters, initialization, reboot, and importing/exporting parameters.

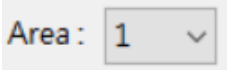





1. Configuration : Opens the page for configuring related module parameters.

2. Threshold Settings.

-  Area Menu: Select the area to be configured.
-  Threshold Switch: When enabled, the module will determine whether the average temperature of the area exceeds the warning or danger values.
- Higher Dangerous Value : Upper danger limit setting (minimum temperature unit: 0.1 °C).
- Higher Warning Value : Upper warning limit setting (minimum temperature unit: 0.1 °C).
- Lower Warning Value : Lower warning limit setting (minimum temperature unit: 0.1 °C).
- Lower Dangerous Value : Lower danger limit setting (minimum temperature unit: 0.1 °C).
-  Save Temporarily: After setting a single area, click  to keep the configuration for that area. Before clicking , the settings will not be written to the module.
-  Import Settings: Allows the user to read the threshold settings from the module into the configuration screen.
-  Save Button: Allows the user to write the configured threshold values into the module.

3. iSN-81x-MRTU Sensor Measurement Parameter Settings.

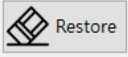
- Emissivity ϵ (0.1 ~ 1) : Emissivity setting. Different materials have different emissivity values. Adjusting the emissivity improves measurement accuracy.
- Offset : Compensation value setting, used to adjust measurement deviations to make results closer to the actual temperature.
-  Temperature Unit : Sets the temperature display unit (Celsius/Fahrenheit).

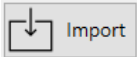
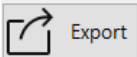
-  Save Parameters: Saves the measurement parameter settings and writes them to the module. This allows specific measurement settings to be stored for quick application in the future.
 -  Load Parameters: Reads previously stored measurement parameters from the module.
4.  Restore Reset Module: Restores all device settings to factory defaults.
 5.  Reboot Reboot: Restarts the running module.
 6. Import or Export Module Settings.
 -  Import Import Settings: Imports all module settings into the software from a previously exported file for adjustment.
 -  Export Export Settings: Exports all module settings in CSV format to the same location as the IR_Configuration.exe program, allowing for quick restoration of parameter settings later.

3.2.5 Diagnostic Messages

The Diagnostic Messages page displays the current area alarm status as text messages, listed one by one.

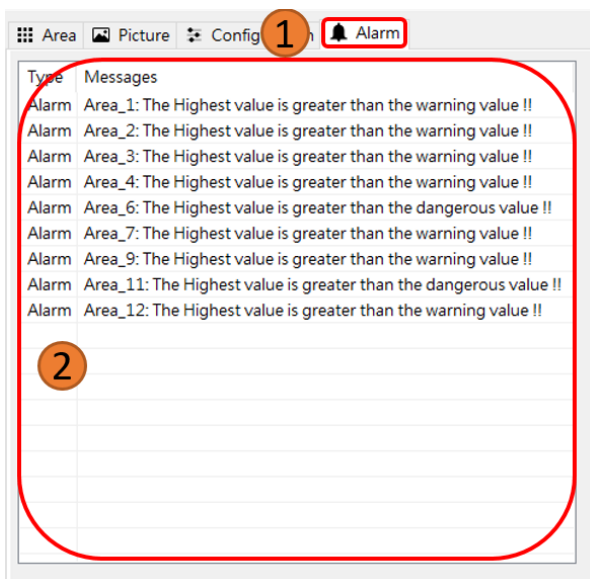



1. Alarm : Open the alarm list page.
2. Types of Diagnostic Messages:
 - Sensor Abnormal : Sensor malfunction.
 - The Average value is lower/higher than the warning value : The average area temperature is lower/higher than the warning value.
 - The Average value is lower/higher than the dangerous value : The average area temperature is lower/higher than the danger value.
 - Threshold setting error : Logical error in the configuration of warning and danger values.



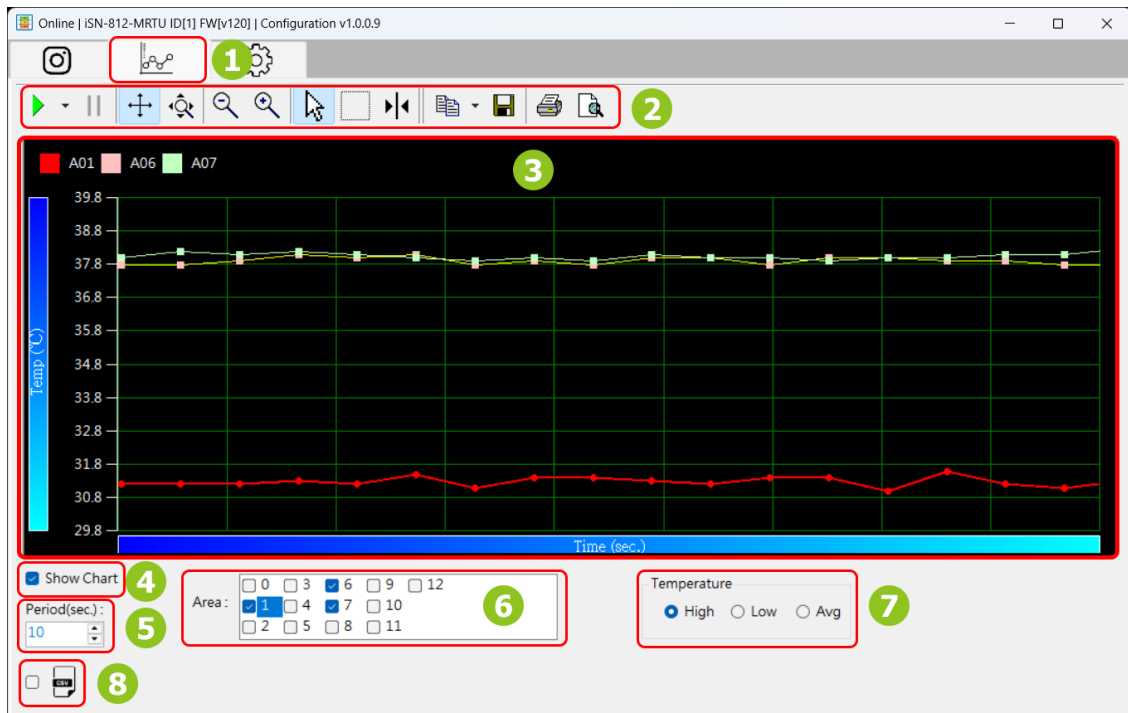









3.2.6 Temperature Data Logging

The IR_Configuration.exe tool provides functions such as temperature data logging, trend chart display, and historical data export to assist users in equipment monitoring and data analysis.



1.  Temperature Trend Chart: Click the Chart tab to open a visualized temperature trend chart. The page includes trend chart tools, display settings, and historical data storage functions.
2. Chart Tools Toolbar:
 -  Resume Tracking: Resumes real-time data tracking after being paused,

allowing the chart to update automatically again.

-  Pause Tracking: Pauses automatic data tracking and updating, keeping the chart in a static state.
 -  Pan: Enables dragging of the X/Y axis to view different data areas.
 -  Zoom: Adjusts the axis scale to closely examine specific data ranges.
 -  Zoom Out: Each click reduces the current X and Y axis scales.
 -  Zoom In: Each click increases the current X and Y axis scales.
 -  Select: Allows selection of chart elements or data for further operations.
 -  Zoom Area: Drag a selection box with the mouse, then zoom into the selected area for a detailed view.
 -  Data Cursor: A feature in data visualization or analysis tools that lets the user move a cursor across the chart or dataset to display detailed information about specific data points.
 -  Copy: Copies the current chart to the clipboard for pasting into other applications.
 -  Save: Saves the chart as an image file (e.g., BMP, JPG, EMF).
 -  Print: Prints the current chart or converts it to formats such as PDF.
 -  Find: Locates specific elements or data points in the chart or dataset.
3. Trend Chart Display Area: Displays the trend chart to be plotted based on the settings, visually presenting temperature changes in different areas.
 4. Show Chart Configure Chart Display: Adjusts how the chart is displayed in data visualization software or reporting systems to better convey data trends and analysis results.

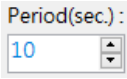
5.  Save Interval: The automatic save interval for CSV files in seconds; data will be periodically written to a CSV file according to the set interval.

6. Area: Selects the area temperature data to be displayed on the trend chart to help analyze or report on specific areas.

7. Temperature: Specifies the type of temperature to be displayed in the trend chart.

- High : Maximum temperature in the area.
- Low : Minimum temperature in the area.
- Avg : Average temperature in the area.

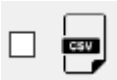
8.  Save CSV File: Starts saving CSV files. When checked, the temperature data will be recorded according to the Period setting, writing each point and area temperature data into a CSV file.

- File Save Location: ..\iSN-8xx_Tool Utility\ThermalData\

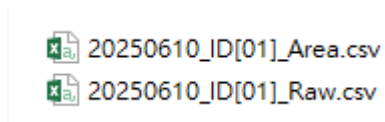

- File Types :

- YYYYMMDD_ID[BatchNumber]_Area.csv: Contains temperature, threshold settings, and diagnostic messages for each area.

	A	B	C	D	E	F	G	H	I	J	K	L	M	N
1	DateTime	Unit	Emissivity	Offset	Area	High	Low	Avg	Switch	WarningL	DangerL	WarningH	DangerH	Alarm
2	2025/6/10 11:09	degC	0	0	1	26.6	24.4	25.7	OFF	100	0	38	0	Normal
3	2025/6/10 11:09	degC	0	0	2	26.9	24.7	25.9	OFF	100	0	38	0	Normal
4	2025/6/10 11:09	degC	0	0	3	27.7	25.6	26.3	OFF	35	0	38	9.5	Normal
5	2025/6/10 11:09	degC	0	0	4	30.2	26.3	28.1	OFF	35	0	38	0	Normal
6	2025/6/10 11:09	degC	0	0	5	26.6	21.2	23.7	OFF	35	0	38	0	Normal
7	2025/6/10 11:09	degC	0	0	6	28.4	24.6	26.1	OFF	35	0	38	40	Normal
8	2025/6/10 11:09	degC	0	0	7	28.5	25.7	26.9	OFF	35	0	38	0	Normal
9	2025/6/10 11:09	degC	0	0	8	28.2	26.4	27.2	OFF	35	0	38	0	Normal
10	2025/6/10 11:09	degC	0	0	9	28.4	24.5	26.3	OFF	35	0	38	0	Normal
11	2025/6/10 11:09	degC	0	0	10	32.2	26.7	27.6	OFF	35	0	38	0	Normal
12	2025/6/10 11:09	degC	0	0	11	29	26.8	27.7	OFF	35	0	38	0	Normal
13	2025/6/10 11:09	degC	0	0	12	28.2	26.5	27.4	OFF	35	-0.1	38	0	Normal

- YYYYMMDD_ID[BatchNumber]_Raw.csv: Contains temperature data for all temperature points.

	A	B	C	D	E	F	G	H	I	J	K	L	M	N	O
1	DateTime	Unit	Emissivity	Offset	THigh	TLow	TAvg	TO_1	TO_2	TO_3	TO_4	TO_5	TO_6	TO_7	TO_8
2	2025/6/10 11:09	degC	0	0	32.2	21.2	26.6	26.5	26.3	25.8	26.6	26.2	26	26.3	26.5
3	2025/6/10 11:09	degC	0	0	32.1	21.2	26.8	27	26.3	26.4	26.4	26.5	25.8	26.7	26.2
4	2025/6/10 11:09	degC	0	0	34	23.4	27.5	30.3	30	27.9	27.6	26.9	27	26.7	27

4 iSN-81x-MTCP Configuration and Monitoring (Web)

The iSN-81x-MTCP provides a web interface, allowing users to configure communication protocols, infrared sensors, and other settings. The web interface also offers real-time thermal images and trend chart displays, enabling users to remotely monitor the temperature distribution on-site.

4.1 Web Login

The iSN-81x-MTCP has a built-in Web Server, allowing users to use a web browser to manage device settings and monitor data in real time.

- Factory default network parameters are as follows:

IP	192.168.255.100
Mask	255.255.0.0
Gateway	192.168.255.254

- If the module IP address is unknown, download the [eSearch Utility](#) and follow the steps below to search and modify it.

Step 1 Click the [Search Server] button to search for the iSN-81x-MTCP.

Step 2 Once the module is found on the network, its name and information will appear in the list. Select the module you want to configure and click the [Configuration UDP] button to allow network settings configuration for that module.

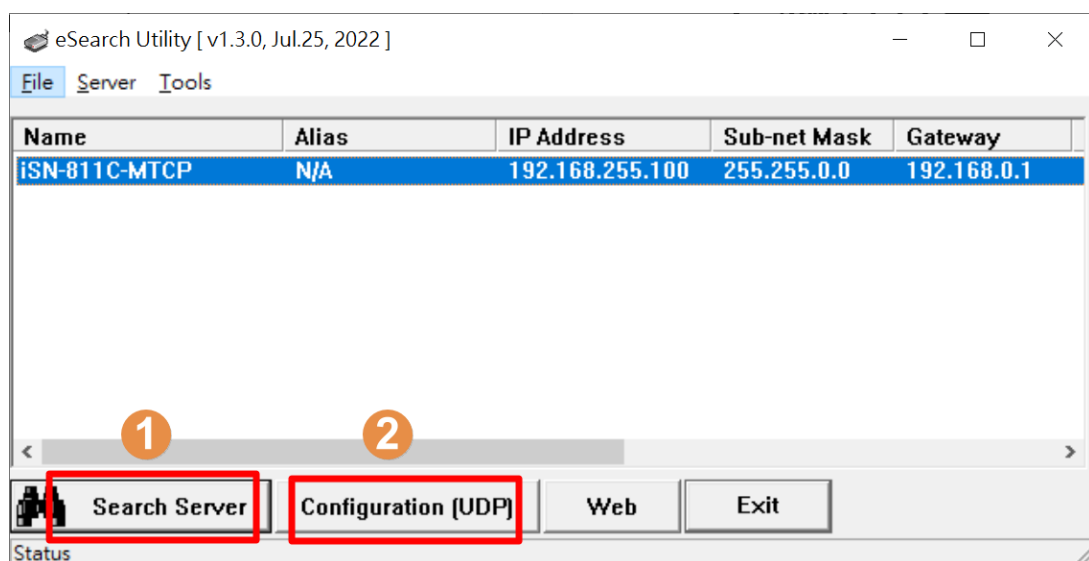

Step 3 Adjust the network parameter values, and after completion, click the [OK] button to apply the network parameter changes to the device.

Configure Server (UDP)

Server Name : iSN-811C-MTCP

DHCP: 0: OFF Sub-net Mask : 255.255.0.0 Alias:

IP Address : 192.168.255.100 Gateway : 192.168.0.1 MAC: ff:ff:ff:ff:ff:ff

Warning!!
Contact your Network Administrator to get correct configuration before any changing!

OK Cancel

DHCP : Dynamic Host Configuration Protocol.

0: OFF : Disable DHCP, manually set IP / Sub-net Mask / Gateway.

1: ON : Enable DHCP.

IP Address : Set the device IP address.

Sub-net Mask : Set the device subnet mask.

Gateway : Set the device gateway.

Alias : Assign a meaningful alias to the server.

MAC : The MAC address of the iSN-81x-MTCP device.

Step 4 The user can use the eSearch Utility to search for the module again (repeat Step 1) to confirm whether the network parameters were successfully modified.

- Open a web browser (recommended: Edge / Chrome / Firefox), and enter the module IP (for example: 192.168.255.100) in the address bar to log in to the web page.

Note: The first time you log in, you must change the password and click the [Submit] button to apply the change. The factory default password is: admin.

Change Password

The length of the password is 12 characters maximum.

Current password:

New password:

Confirm new password: Submit

Current password : The current login password set by the user.

New password : The new login password.

Confirm new password : Re-enter the new password to confirm it is correct.

- After successfully connecting to the module's web page, the site will display as shown in the figure below.

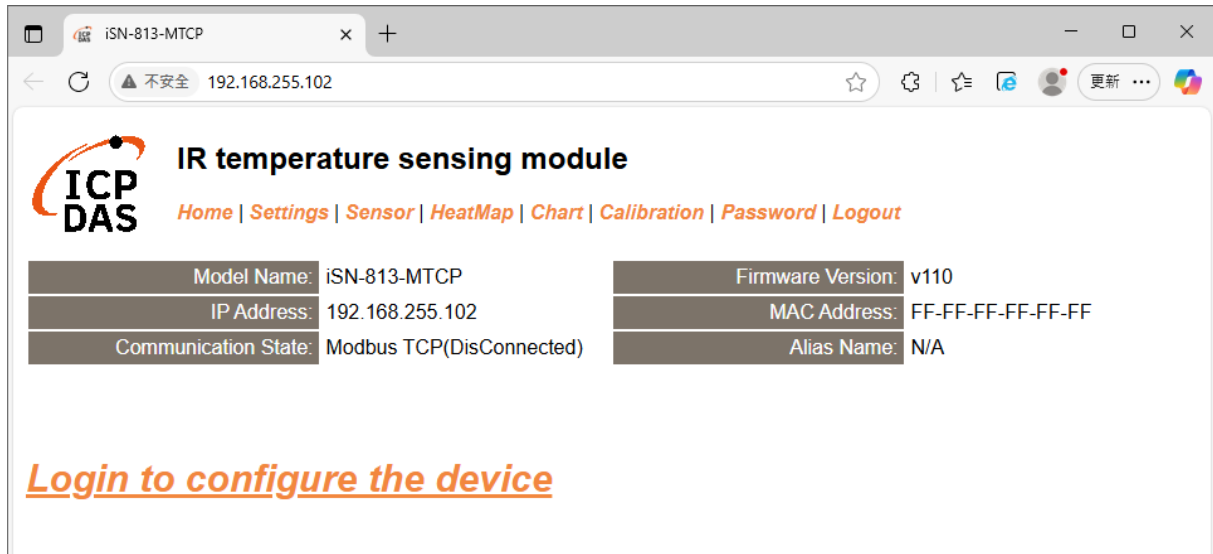

At the top of the web page is the function menu, described as follows:

Home : Home page, module login.

Settings : IP, communication protocol, restore to factory defaults, etc.

Sensor : Emissivity, offset, area threshold values, etc.

HeatMap : Thermal image, temperature threshold detection for each area.

Chart : Temperature trend chart for each area.

Calibration : Adjust temperature offset values, calculate sensing range.

Password : Change password.

Logout : Log out of the module.

4.2 [Home]

This web interface is designed specifically for infrared temperature sensing modules, suitable for equipment management and data monitoring in harsh industrial environments. Through the home page, users can instantly track temperature changes and configure the module, enhancing monitoring efficiency and operational flexibility. The top of the page contains multiple navigation links, including: "Home," "Settings," "Sensor," "HeatMap," "Chart," "Calibration," "Password," and "Logout," allowing users to quickly switch between different functional modules. In the center of the interface, an orange prompt message prominently displays: "Please log in to configure the device," reminding users to complete authentication before proceeding with system settings and device management to ensure operational security and data confidentiality.

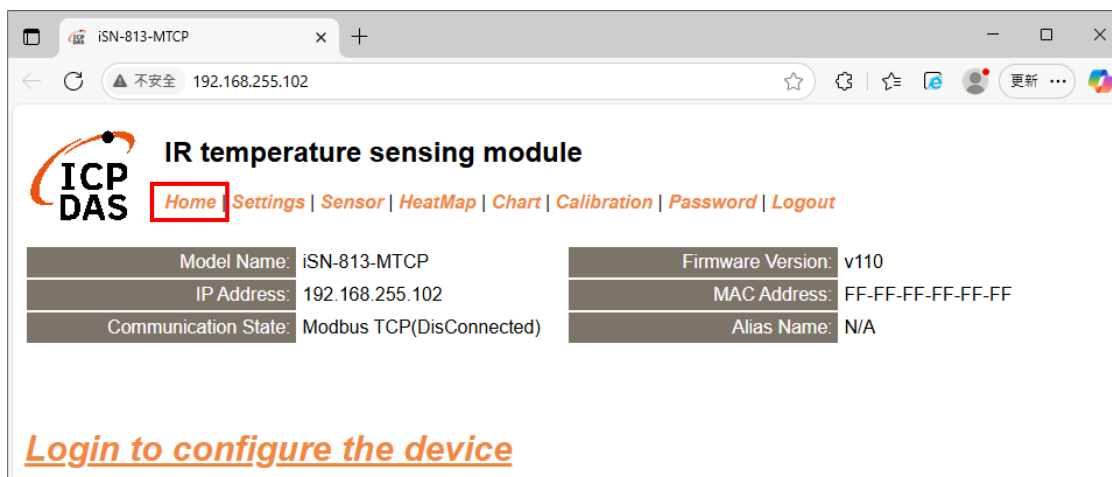

- Provides module information and module login functions.

1	Model Name:	iSN-812-MTCP
2	IP Address:	172.16.77.35
3	Communication State:	RESTful API(DisConnected)

4	Firmware Version:	v120
5	MAC Address:	00-0D-E0-92-00-03
6	Alias Name:	N/A

7 [Login to configure the device](#)

1. Model Name : The module model.
2. IP Address : The current IP address of the module.
3. Communication state : The communication protocol and current connection status.
4. Firmware version : The current firmware version of the module.
5. MAC Address: The module's MAC address.
6. Alias Name : The module's alias, which can be modified on the [Settings] page.
7. Indicates not logged in; if the module login is successful, the following message will be displayed.

Login Successfully!!

4.3 [Settings]

Clicking the "Settings" navigation link will direct the webpage to the device management settings page. This interface provides several core configuration functions to help users adjust and maintain the system according to their needs.

The screenshot shows a web browser window with the URL `192.168.255.102`. The page title is "IR temperature sensing module" and the navigation menu includes [Home](#), [Settings](#) (highlighted), [Sensor](#), [HeatMap](#), [Chart](#), [Calibration](#), [Password](#), and [Logout](#).

Device IP Settings

Device IP Settings	Current	New	Comment
Address Type:	Static IP	Static IP ▾	Dynamic or Static IP(Default)
Static IP Address:	192.168.255.102	<input type="text" value="192.168.255.102"/>	Default= 192.168.255.100
Subnet Mask:	255.255.0.0	<input type="text" value="255.255.0.0"/>	Default= 255.255.0.0
Gateway:	192.168.255.254	<input type="text" value="192.168.255.254"/>	Default= 192.168.255.254

Communication Settings

Communication	Current	New	Comment
Mode:	Modbus TCP	Modbus TCP ▾	Modbus TCP(Default), RESTful API or MQTT
Server port:	502	<input type="text" value="502"/>	Default= 502

General Settings

Network	Current	New	Comment
Web Auto-logout:	10	<input type="text" value="10"/>	(1 ~ 255 minutes, 10=default, 0=disable)

Misc.	Current	New	Comment
Alias Name:	N/A	<input type="text" value="N/A"/>	(Max. 18 chars)

Restore Factory Defaults

Restore all options to their factory default states:

Forced Reboot

Copyright © 2025 ICP DAS Co., Ltd. All rights reserved.

4.3.1 IP Address Settings

Primarily used to manage the network connection method of the device, ensuring that it can communicate correctly with other network devices.

Device IP Settings	Current	Updated	Comment
1 Address Type:	Static IP	Static IP ▾	Dynamic or Static IP(Default)
2 Static IP Address:	172.16.77.35	172.16.77.35	Default= 192.168.255.100
3 Subnet Mask:	255.240.0.0	255.240.0.0	Default= 255.255.0.0
4 Gateway:	172.18.0.254	172.18.0.254	Default= 192.168.255.254
<input type="button" value="Update Settings"/>			

- 1. Address Type** : Select "Static IP" or "DHCP."
- 2. Static IP Address** : Static IP address. When Address Type is set to Static IP, the module IP address can be set manually.
- 3. Subnet Mask** : Subnet mask address. When Address Type is set to Static IP, the module subnet mask can be set.
- 4. Gateway** : Gateway address. When Address Type is set to Static IP, the module gateway address can be set.

4.3.2 Communication Settings

Allows users to configure the iSN-81x-MTCP module's communication mode to suit different system integration requirements. Only one of the following three communication protocols can be used at a time to avoid communication conflicts and ensure stable operation.

Available communication protocol modes:

- **Modbus TCP** : Suitable for traditional industrial control systems, exchanging data via TCP/IP. Supports standard slave polling mode with high compatibility and stability.
- **RESTful API** : Provides a lightweight HTTP communication method suitable for integration with modern web systems or cloud platforms. Supports reading and writing JSON data. Allows fast deployment and ease of development.
- **MQTT** : Suitable for IoT architecture, using a publish/subscribe mechanism. Supports low-bandwidth, high-efficiency communication. Ideal for remote sensor data upload and real-time monitoring applications.

The three communication modes cannot be enabled simultaneously. They must be selected and configured according to the actual application scenario. Settings can only be modified after login to ensure system security and access control.

Communication Settings

Communication	Current	New	Comment
Mode:	Modbus TCP	Modbus TCP ▾	Modbus TCP(Default), RESTful API or MQTT
Server port:	502	502	Default= 502
Update Settings			

Protocol	Server / Client	Content
Modbus TCP	Server	Modbus register map (see section 5.1)
RESTful	Client	JSON (see section 5.2)
MQTT	Client	

■ Modbus TCP Mode

When selecting Modbus TCP mode, the display and parameters are as follows:

Communication	Current	New	Comment
Mode:	Modbus TCP	Modbus TCP ▾	Modbus TCP(Default), RESTful API or MQTT
1 Server port:	502	502	Default= 502
Update Settings			

1. Server port : Modbus TCP communication port number.

■ RESTful API Mode

When selecting RESTful API mode, the display and parameters are as follows:

Communication	Current	New	Comment
Mode:	RESTful API	RESTful API ▾	Modbus TCP(Default), RESTful API or MQTT
1 Server URI:	192.168.1.1	192.168.1.1	e.g. www.server.com or 19.168.255.1 Default= 192.168.255.1 http://ServerURI/restapi-icpdas/
2 Server port:	80	80	Default= 80
3 [POST] Interval:	2	2	2 ~ 600 seconds, 2=default
4 DataSet:	irdata+image	irdata+image ▾	Select the type of data to be transferred
API: http://192.168.1.1:80/restapi-icpdas/ JSON Format: { "macno": MAC number "model": model name "irdata": temperature data "shift": shift data(used to align the image with the irdata) "image": image data }			

1. Server URI : The IP address or URL of the server to connect to. The URI must end with **/restapi-icpdas/** Example : http://ServerURI/restapi-icpdas/

2. Server port : The server port number to connect to.

3. [POST] Interval : Interval time between each JSON message sent, in seconds.

4. DataSet: Select whether the JSON data includes "irdata" temperature and "image" (image data). This setting applies only to iSN-811C-MTCP.

■ MQTT Mode

When selecting MQTT mode, the display and parameters are as follows:

Communication	Current	New	Comment
Mode:	RESTful API	MQTT client ▾	Modbus TCP(Default), RESTful API or MQTT
1 Broker URI:	192.168.255.1	192.168.255.1	e.g. www.server.com or 19.168.255.1 Default= 192.168.255.1
2 Broker port:	1883	1883	Default= 1883
3 Reconnection interval:	10	10	10 ~ 120 seconds, 10=default
4 Keep alive interval:	30	30	10 ~ 120 seconds, 30=default
5 [Publish] interval:	10	10	10 ~ 120 seconds, 10=default
6 QoS:	0	0	0 – At most once 1 – At least once 2 – Exactly once 0=default
7 Last Will:	Disable	Disable ▾	Enable/Disable Last Will
8 Authentication:	Disable	Enable ▾	Enable/Disable Authentication
9 User Name:	icpdas	icpdas	(Max. 32 chars)
10 Password:	icpdas	icpdas	(Max. 32 chars)
11 DataSet:	irdata+image	irdata+image ▾	Select the type of data to be transferred

1. **Broker URI** : IP address of the MQTT broker to connect to.
2. **Broker port** : Port of the MQTT broker to connect to.
3. **Reconnection interval** : Time to wait before retrying a connection after failure, in seconds.
4. **Keep alive interval** : Ensures that the Client and Broker are active and available for communication. If the Client sends no messages within the Keep Alive interval, it must send a PINGREQ packet to the Broker, and the Broker must reply with a PINGRESP packet. If no PINGREQ or messages are sent within 1.5 times the Keep Alive interval, the Broker will disconnect the Client. (Unit: seconds).
5. **[Publish] interval** : Interval time between each JSON message sent, in seconds.
6. **QoS**:
 - 0 – At most once : Sends the message at most once.
 - 1 – At least once : Ensures the message is sent at least once.
 - 2 – Exactly once : Guarantees the message is delivered exactly once.
7. **Last Will** : Notifies other Clients when a Client disconnects unexpectedly. The module can retain the Last Will message (LWT) at the Broker. When the module disconnects unexpectedly, the Broker will send this LWT message to all Clients subscribed to the "offline" topic.
8. **Authentication** : In some cases, the MQTT Broker may require the Client to provide authentication via a username and password. Enable to turn on authentication; disable to turn it off.
9. **User Name** : Username for MQTT broker authentication.
10. **Password** : Password for MQTT broker authentication.

11. DataSet : Select whether the JSON data includes temperature and image. Applicable only to iSN-811C-MTCP.

Note:

- ◆ MQTT Client ID : Fixed as module name + underscore + last 6 digits of MAC address, e.g., ISN812_920003.
- ◆ MQTT Topic : Fixed as IR/Temp/ClientID, e.g., IR/Temp/ISN812_920003.
- ◆ LWT 的 Topic : Fixed as “offline”
- ◆ LWT Message : Fixed as “offline msg”
- ◆ LWT QoS : Fixed as “0”

4.3.3 General Settings

Includes two options, network and alias, allowing users to adjust features to meet their needs.

Network		Current	Updated	Comment
1	Web Auto-logout:	10	<input type="text" value="10"/>	(1 ~ 255 minutes, 10=default, 0=disable)
Misc.		Current	Updated	Comment
2	Alias Name:	N/A	<input type="text" value="N/A"/>	(Max. 18 chars)
<input type="button" value="Update Settings"/>				

- 1. Web Auto-logout** : Automatically logs out from the webpage after a timeout (unit: minutes).
- 2. Alias Name** : Sets the module alias, up to 18 characters.

Fill Light : iSN-811C-MTCP provides a fill light switch. In dark environments, turning on the fill light can enhance image quality.

Camera		Current	Updated	Comment
	Fill light:	OFF	<input type="button" value="OFF v"/>	The fill light helped to improve the contrast of the image

4.3.4 Restore Factory Defaults

Restores the module’s settings and parameter configuration to factory state.

Restore Factory Defaults

Restore all options to their factory default states:	1 <input type="button" value="Restore Defaults"/>
---	--

Forced Reboot	2 <input type="button" value="Reboot"/>
----------------------	--

1. **Restore Defaults** : Restores all options to factory default values.
2. **Reboot** : Forces the module to restart.

4.4 [Sensor]

Clicking the "Sensor" link in the navigation bar will direct the webpage to the sensor parameter settings page. This page is specifically designed for infrared sensing modules and provides various parameter adjustment functions required for precise heat source monitoring.

Adjustable settings include: emissivity, offset, and area threshold values. This page requires login before settings can be modified to ensure operational security and parameter change control, preventing unauthorized access.

The screenshot displays the web interface for the ICP DAS IR temperature sensing module. The browser address bar shows the URL 192.168.255.102. The page title is "IR temperature sensing module". The navigation bar includes links for Home, Settings, Sensor (highlighted), HeatMap, Chart, Calibration, Password, and Logout. System information is displayed in a table:

Model Name:	iSN-813-MTCP	Firmware Version:	v110
IP Address:	192.168.255.102	MAC Address:	FF-FF-FF-FF-FF-FF
Communication State:	Modbus TCP(DisConnected)	Alias Name:	N/A

The "IR Sensor Settings" section includes a legend for "Disable", "Enable", and "Set & Not yet updated". Below this is a 3x4 grid of sensor areas numbered 1 through 12.

Threshold Area #01	Current	New	Comment	Settings
Switch:	Disable	Disable	Enable/Disable this area	
Lower Dangerous value (LD):	0	0	Lower limit of dangerous value Value range:-3000~3000, Default= 0 e.g. Value: 1075 -> 107.5°C	
Lower Warning value (LW):	0	0	Lower limit of warning value Value range:-3000~3000, Default= 0	

Copyright © 2025 ICP DAS Co., Ltd. All rights reserved.

4.4.1 IR Sensor Settings

Temperature threshold settings for each area of the infrared sensor and parameter settings for the infrared sensor.

■ Disable ■ Enable ■ Set & Not yet updated



Threshold Area #06	Current	New	Comment	Settings
2	Switch: Enable	Enable ▾	Enable/Disable this area	7 Set
3	Lower Dangerous value (LD): 0	0	Lower limit of dangerous value Value range:-3000~3000, Default= 0 e.g. Value: 1075 -> 107.5°C	
4	Lower Warning value (LW): 200	300	Lower limit of warning value Value range:-3000~3000, Default= 0 e.g. Value: 905 -> 90.5°C	
5	Higher Warning value (HW): 800	800	Higher limit of warning value Value range:-3000~3000, Default= 0 e.g. Value: 905 -> 90.5°C	
6	Higher Dangerous value (HD): 1000	1000	Higher limit of dangerous value Value range:-3000~3000, Default= 0 e.g. Value: 1075 -> 107.5°C	
Sensor				
8	Offset: 0	0	Measuring temp.+Offset(Default= 0)= actual temp. Unit: 0.1°C e.g. 173->17.3°C	
9	Emissivity: 95	95	Value range:10~100(Emissivity: 0.1~1.0), Default= 95 e.g. Value: 15 ->emissivity: 0.15	

1. Displays the status of the threshold value switch for each area, and allows clicking on an area to configure its threshold values.

■ : This area has temperature threshold detection disabled.

■ : This area has temperature threshold detection enabled.

■ : This area has been modified but not yet updated.

2. **Switch** : Temperature threshold on/off switch for the area.
3. **Lower Dangerous value** : Lower limit for the danger threshold, unit: 0.1°C.
4. **Lower Warning value** : Lower limit for the warning threshold, unit: 0.1°C.
5. **Higher Warning value** : Upper limit for the warning threshold, unit: 0.1°C.
6. **Higher Dangerous value** : Upper limit for the danger threshold, unit: 0.1°C.
7. **Set** : After completing the area threshold value configuration, click [Set] to write the settings. The color of the area will change to ■ .

- 8. **Offset** : Temperature compensation value, unit: 0.1°C.
- 9. **Emissivity** : The emissivity of the object being measured.

For details on temperature threshold values, please refer to Appendix 1 of this user manual.

4.5 [HeatMap]

Clicking the "HeatMap" link in the navigation bar directs the webpage to the real-time thermal image monitoring page, which provides a visual display of temperature distribution and status interpretation for each area.

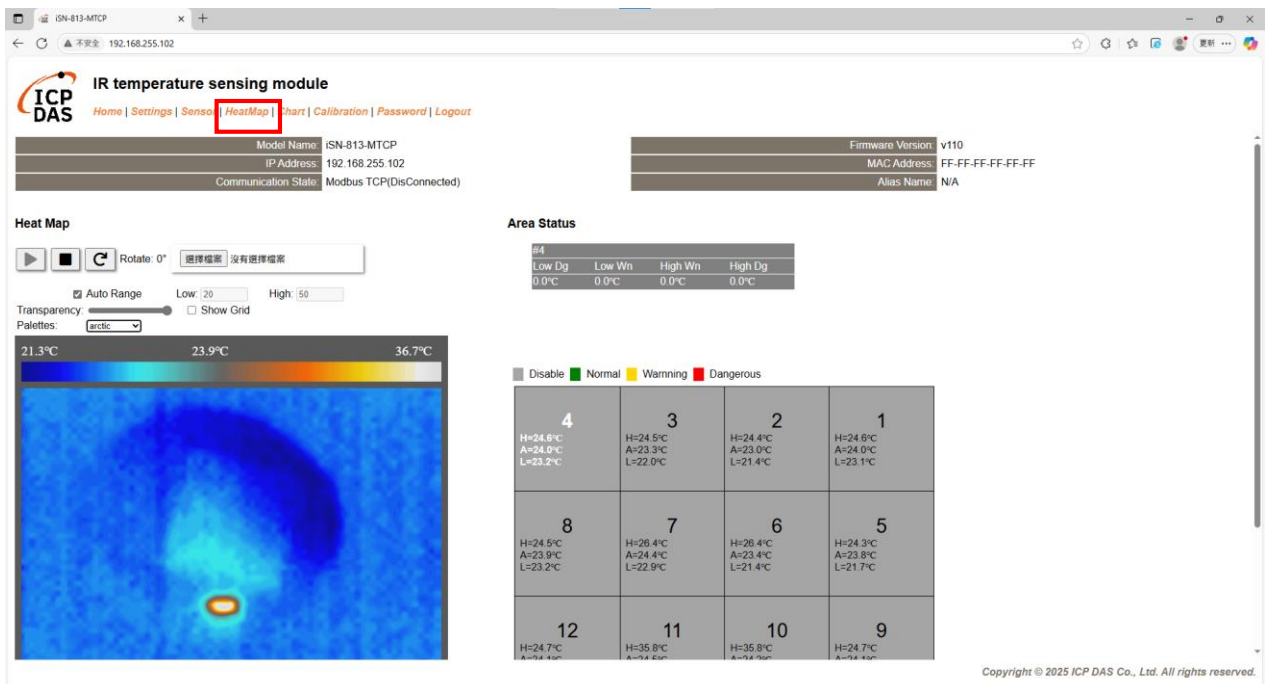

■ HeatMap

The image uses color variations to display temperature distribution or correlations.

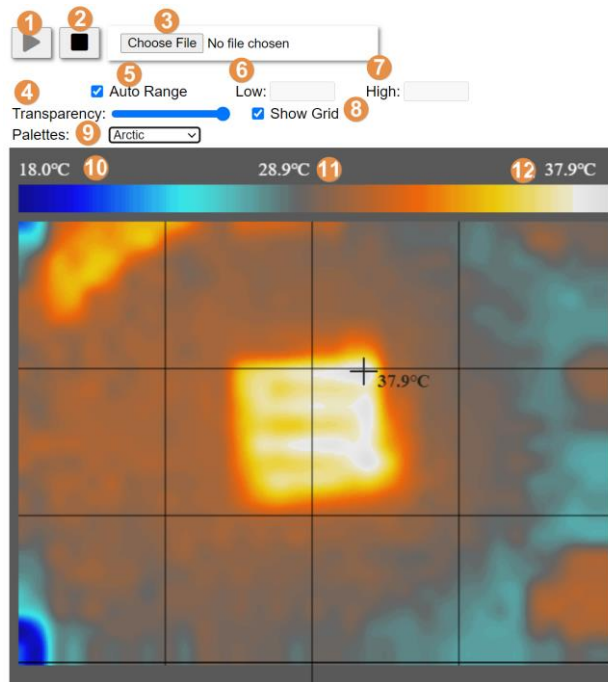

1. Enable thermal image update.
2. Disable thermal image update.
3. Choose File : Select a file, allowing the user to add an image to the thermal map as a background photo, helping to better understand the temperature distribution (supported only by iSN-812-MTCP/iSN-813-MTCP modules).
4. Transparency : Thermal image transparency. When a background photo is added, adjusting the transparency allows for clearer visualization of the temperature distribution, as shown in the example below.

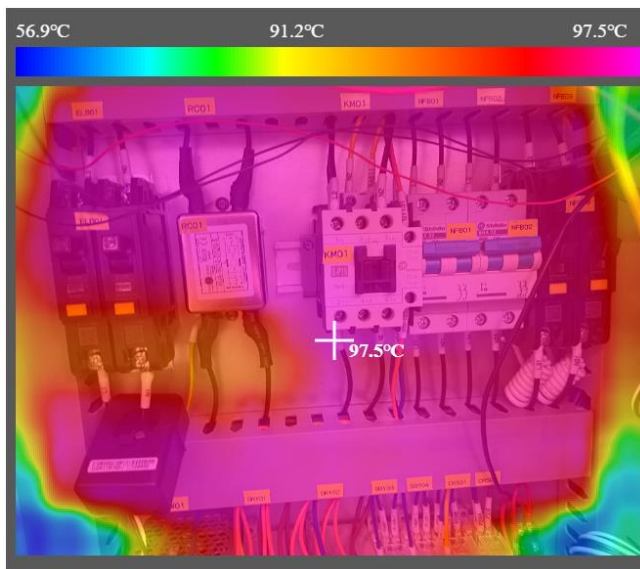

5. Auto Range : Automatically adjusts the temperature color scale, with the scale range corresponding to the highest and lowest measured temperatures.

When Auto Range is checked, the thermal map is drawn using the highest and

lowest temperatures from the measured values.

When Auto Range is unchecked, the thermal map is drawn using the Low and High temperature settings.

6. Low : Used when Auto Range is unchecked; sets the minimum temperature for the color scale in the display.
7. High : Used when Auto Range is unchecked; sets the maximum temperature for the color scale in the display.
8. Show Grid : If checked, displays the area grid lines.
9. Palettes : Provides color scale options, allowing the user to interpret the thermal image more clearly.
10. Minimum Temperature : The current minimum temperature corresponding to the measured range in the color scale.
11. Average Temperature : The current average temperature corresponding to the measured range in the color scale.
12. Maximum Temperature : The current maximum temperature corresponding to the measured range in the color scale.

■ **Area Status**

Mainly used to display the alarm status of different areas, with color differences allowing the user to quickly determine whether abnormal temperatures are present in the monitored areas.

#3				
Low Dg	Low Wn	High Wn	High Dg	AvgT
0.0	20.0	25.0	26.0	26.6

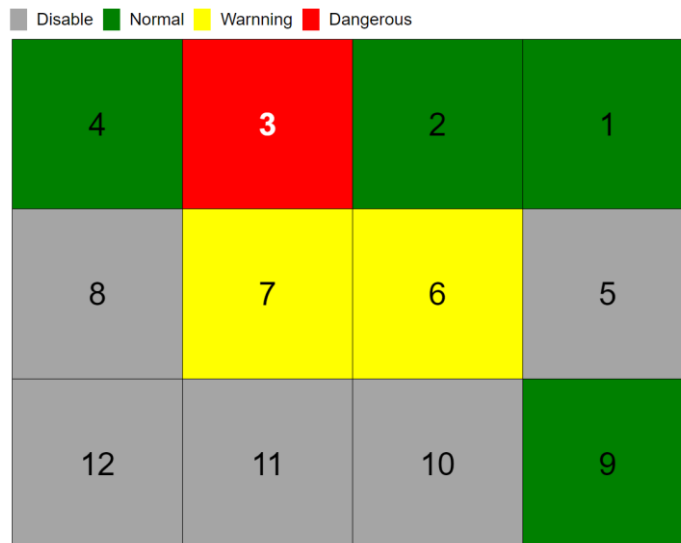

- ◆ Displays the temperature threshold status for each temperature area.
- ◆ iSN-811C-MTCP is divided into 16 areas; iSN-812-MTCP / iSN-813-MTCP are divided into 12 areas.
- ◆ Gray : Indicates that temperature threshold judgment is disabled for the area.
- ◆ Green : Indicates the area's temperature status is normal.
- ◆ Yellow : Indicates the area's temperature status has exceeded the warning threshold.
- ◆ Red : Indicates the area's temperature status has exceeded the danger threshold.

For details on temperature thresholds, please refer to Section 5.1 of this manual.

4.6 [Chart]

Clicking the "Chart" navigation link directs the system to the temperature trend analysis page, providing a visual presentation of historical temperature data for each monitored area.

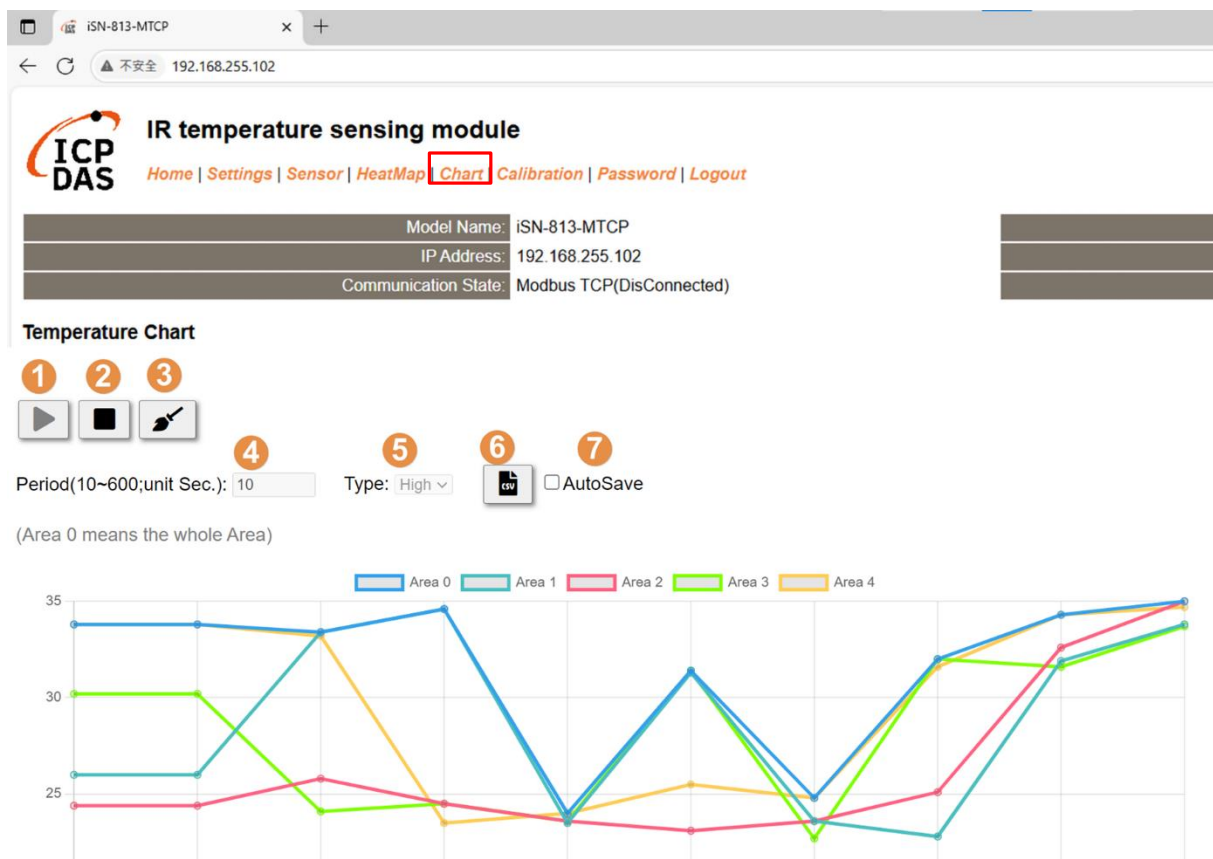

1. Enable trend chart display.
2. Disable trend chart display.
3. Clear the trend chart from the display.

4. Set the recording interval for temperature data, in seconds.
5. Type : Type: Set the type of temperature to display — maximum, minimum, or average.
6.  : Saves the current temperature data as a CSV file, stored in the iSN-8xx_Tool Utility folder \iSN-8xx_Tool\ThermalData directory
7. AutoSave : When checked, the system will automatically save the temperature data CSV file every hour.
8. CSV file naming format :
 - YYYYMMDDHHMM_Area.csv : Contains temperatures for each area, threshold settings, and diagnostic messages.
 - YYYYMMDDHHMM_Raw.csv : Contains temperature data for all measurement points.

4.7 [Calibration]

When the user clicks the "Calibration" navigation link, the system directs to the infrared temperature module calibration settings page. This page provides fine-tuning functions to improve sensing accuracy and environmental adaptability.

IR temperature sensing module
 Home | Settings | Sensor | HeatMap | Chart | **Calibration** | Password | Logout

Central temp.: 252 Average temp.: 241
 Highest temp.: 356 Highest temp. point: 3320
 Lowest temp.: 215 Lowest temp. point: 1147

Sensor	Current	New	Comment
Offset:	0	<input type="text" value="0"/>	Measuring temp.+Offset(Default= 0)= actual temp. Unit: 0.1°C e.g. 173->17.3°C
Emissivity:	95	<input type="text" value="95"/>	Value range:10~100(Emissivity: 0.1~1.0), Default= 95 e.g. Value: 15 ->emissivity: 0.15

Central Highest Lowest ①

Heatmap:

P057	286	277	241	241	250	240	238	243	P001
P058	262	241	242	236	255	242	239	236	P002
P059	238	236	234	240	241	236	240	233	P003
P060	240	241	236	240	243	240	241	238	P004
P061	240	240	243	237	236	237	238	234	P005
P062	236	241	234	236	241	239	234	233	P006
P063	238	235	235	236	239	236	235	236	P007
P064	231	235	236	230	234	236	235	232	P008

D:S

The ratio of the sensing distance to the surface area of the measured object.
 X: 60° / D : S = 1 : 1.15
 Y: 60° / D : S = 1 : 1.15

D = (cm) ②
 X:S = (cm) / (cm/pixel)
 Y:S = (cm) / (cm/pixel)

D (Distance): The distance from the sensor to the measured object.
 S (Spot Size): The measurable length of the sensor.

- The system displays real-time temperature values for each pixel in the infrared thermal image, allowing the user to accurately grasp the overall heat distribution of the monitored area. The user can refer to the central point temperature as a baseline to adjust the overall temperature offset value, correcting sensing errors and improving measurement accuracy.
- D: Enter the distance between the module and the measured object.
 X:S: Calculates the detectable X-axis length based on D.
 Y:S: Calculates the detectable Y-axis length based on D.

4.8 [Password]

When the user clicks the "Password" link in the navigation bar, the system navigates to the account password management page. This page allows the user to securely change the login password to enhance account protection and maintain system access security.

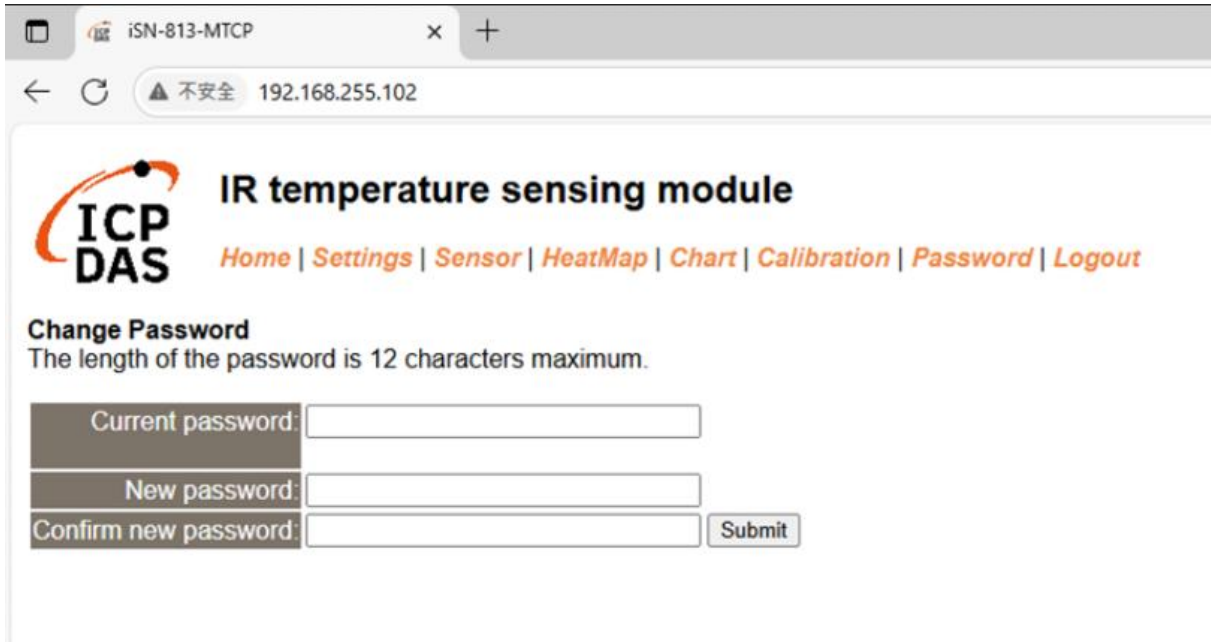

The screenshot shows a web browser window with the address bar displaying "iSN-813-MTCP" and "192.168.255.102". The page title is "IR temperature sensing module". The navigation bar includes links for "Home", "Settings", "Sensor", "HeatMap", "Chart", "Calibration", "Password", and "Logout". The main content area is titled "Change Password" and includes the instruction "The length of the password is 12 characters maximum." Below this, there are three input fields: "Current password:", "New password:", and "Confirm new password:". A "Submit" button is located to the right of the "Confirm new password" field.

Enter the current password, then enter the new password.

4.9 [Logout]

When the user clicks the "Logout" link in the navigation bar, the system immediately logs out and redirects to the home ([Home]) page.

4.10 Forgotten Web Password

If the web password is forgotten and you cannot log in to the web interface:

Step 1 While the module is operating normally, switch the toggle to the [Init] position.



Step 2 The module IP and web password will be temporarily changed as follows:

IP	192.168.255.100
Mask	255.255.0.0
Gateway	192.168.255.254
Password	admin

Step 3 Refer to section 4.8 to set a new password.

Step 4 The module will restart; switch the toggle to the [Run] position and power on again.

5 Modbus register table and JSON format

5.1 Modbus Command and register table

Modbus master can use the following function code to read or write data to iSN-81x series. FC 3 and FC4 can read data from registers. FC6 and FC16 can write data to the register.

Function Code	Description
3	Read multiple registers.
4	Read multiple registers.
6	Write Single register.
16	Write multiple registers.

Register table

Modbus address (Decimal)	Function	R/W	Data length	Description
Modbus Holding Registers (4xxxx, 0 based)				
0	Threshold switch of each area	R/W	1 word	0: Close, 1: Open Each area uses 1 bit
1~16	Lower Warning threshold value of each area	R/W	16 words	Each area uses 1 word Unit: 0.1°C e.g. Value: 515->51.5°C
17~32	Lower Danger threshold value of each area	R/W	16 words	Each area uses 1 word Unit: 0.1°C e.g. Value: 515->51.5°C
33~48	Higher Warning threshold value of each area	R/W	16 words	Each area uses 1 word Unit: 0.1°C e.g. Value: 515->51.5°C
49~64	Higher Danger threshold value of each area	R/W	16 words	Each area uses 1 word Unit: 0.1°C e.g. Value: 515->51.5°C
65	Offset value	R/W	1 word	Measuring temperature+ Offset value=

Modbus address (Decimal)	Function	R/W	Data length	Description
				actual temperature Unit: 0.1°C e.g. 173->17.3°C
66	Emissivity	R/W	1 word	Value range:10~100 (Emissivity: 0.1~1.0) When the value exceeds the valid range. emissivity is 0.95. e.g. Value: 15 ->emissivity: 0.15
67	Temperature unit	R/W	1 word	0: degree C 1: degree F
68	Device reset	R/W	1 word	0: Idle 1: Reset 128: Restore Factory Default
69	The switch of diagnostic message	R/W	1 word	0: Open, 1: Close
70~99	X	X	X	Reserve
100~102	MAC Address	R	3 words	Only TCP devices have these setting, RTU devices reserve.
103	NetID	R	1 word	Value:1~31 Only RTU devices have these setting, TCP devices reserve.
104	Baudrate (bps)	R	1 word	960: 9600 bps 1920: 19200 bps 3840: 38400 bps 5760: 57600 bps 11520: 115200 bps Only RTU devices have these setting, TCP devices reserve.
105	Firmware version	R	1 word	Value: 235 -> Ver. 23.5
106	System diagnostic	R	1 word	0: normal

Modbus address (Decimal)	Function	R/W	Data length	Description
	message			1: sensor error
107~115	X	X	X	Reserve
116	Threshold Setting Diagnosis Please refer to Appendix 1, Item 2 of this manual.	R	1 words	Each area uses 1 bits 0: normal 1: abnormal
117~118	Threshold Diagnostic Messages Please refer to Appendix 1, Item 3 of this manual.	R	2 words	Each area uses 2 bits 0: normal 1: over warning value 2: over danger value
119	Pixel	R	1 word	64/768/4800, etc.
120	Device model	R	1 word	811/812/813, etc.
121	Sensor temperature (TA)	R	1 word	Unit: 0.1°C e.g. Value: 515->51.5°C
122	Central temperature	R	1 word	Unit: 0.1°C e.g. Value: 515->51.5°C
123	Average temperature	R	1 word	Unit: 0.1°C e.g. Value: 515->51.5°C
124	The highest temperature	R	1 word	Unit: 0.1°C ex: Value: 515->51.5°C
125	The highest temperature point	R	1 word	
126	The lowest temperature	R	1 word	Unit: 0.1°C e.g. Value: 515->51.5°C
127	The lowest temperature Point	R	1 word	
128~143	The highest temperature of each area	R	16 words	Each area uses 1 word Unit: 0.1°C e.g. Value: 515->51.5°C

Modbus address (Decimal)	Function	R/W	Data length	Description
144~159	The lowest temperature of each area	R	16 words	Each area uses 1 word Unit: 0.1°C e.g. Value: 515->51.5°C
160~175	Average temperature of each area	R	16 words	Each area uses 1 word Unit: 0.1°C e.g. Value: 515->51.5°C
iSN-811 series: 176~239 iSN-812 series: 176~943 iSN-813 series: 176~4975	All temperature	R	iSN-811: 64 iSN-812: 768 iSN-813: 4800 Words	Each area uses 1 word Unit: 0.1°C e.g. Value: 515->51.5°C

5.2 JSON Format

```
{
  "macno": MAC address, // MAC address of module
  "model": Model Name, //model of module
  "irdata": temperature data, // Temperature per pixel
  "shift": Shift value, // iSN-811C-MTCP only
  "image": image data // Camera's base64 image data, iSN-811C-MTCP
only
}
```

Appendix 1 Diagnostic Messages

When an abnormality occurs in the iSN-81x series or the temperature exceeds the threshold value, the iSN-81x series will display a diagnostic message and the Status LED will flash. The following diagnostic messages are currently provided.

Type	Messages
System diagnostics	Sensor error.
Threshold setting diagnostics	Threshold value setting error.
Threshold value diagnostics	Temperature is greater than Warning threshold value.
	Temperature is greater than danger threshold value.

1. Sensor error :

- Modbus address : 106
- Modbus value : 0x0001
- Explanation: iSN-81x series can't read the temperature data from sensor.

2. Threshold value setting error :

- Modbus address : 116.
- Each area uses 1bit.
 - Value 0: Threshold setting normal.
 - Value 1: Threshold setting abnormal. The module will turn off the threshold switch.
- Explanation: If the threshold setting is error, please check the warning threshold value and the danger threshold value match the requirement of the threshold setting.
- example :

Modbus address	116	
Value(Hex)	0x0302	
Bit	8~15	0~7
Bit Value	0x03	0x02
Area number	2、9、10	
Error type	Threshold setting of Area 2, 9, 10 is abnormal.	

3. Threshold value diagnostic message :

- Modbus address : 117~118.
- Each area uses 2 bits.
- Modbus value:
 - 0 : normal.
 - 1 : Temperature is over than warning threshold value.
 - 2 : Temperature is over than danger threshold value.
- Example :

Modbus address	117															
Value	0x9845															
Bit	15	14	13	12	11	10	9	8	7	6	5	4	3	2	1	0
Bit Value	1	0	0	1	1	0	0	0	0	1	0	0	0	1	0	1
Area	8		7		6		5		4		3		2		1	
Status	Over than danger threshold value		Over than Warning threshold value		Over than danger threshold value		Normal		Over than Warning threshold value		Normal		Over than Warning threshold value		Over than Warning threshold value	

Modbus Address	118															
Value	0x6412															
Bit	15	14	13	12	11	10	9	8	7	6	5	4	3	2	1	0
Bit Value	0	1	1	0	0	1	0	0	0	0	0	1	0	0	1	0
Area	16		15		14		13		12		11		10		9	
Status	Over than Warning threshold value		Over than danger threshold value		Over than Warning threshold value		Normal		Normal		Over than Warning threshold value		Normal		Over than danger threshold value	

If you don't want iSN-81x series to shows any diagnostic messages, Set the value of Modbus address 69 to 1, and then iSN-81x series will close all diagnostic message.