



**GST-43-M**  
**Smart Earthquake Controller**  
**With Intensity Meter**  
**User Manual**

- ✧ Version: 1.00      2010/06
- ✧ ICP DAS Co., Ltd.
- ✧ No. 111, Kuangfu N. Rd., Hukou Shiang,  
Hsinchu County, 30351, Taiwan(R.O.C.)
- ✧ TEL:886-3-597-3366    FAX:886-3-597-3733
- ✧ <http://www.icpdas.com>



1. Features.....	6
2. Application Architecture .....	7
3. Wiring.....	8
3.1. Wiring .....	8
3.2. Information for Power LED and 7 Segment LED Display .....	9
ⓄPower LED.....	9
Ⓞ7 Segment LED Display .....	9
3.3. Digital Inputs Configurations .....	9
Ⓞ Reset to Factory Setting .....	9
Ⓞ Display IP Information.....	9
Ⓞ Display The Last Earthquake Information .....	10
3.4. RTD (Real Time Data stream) Output Control .....	10
3.5. Parameters for Autoexec.bat.....	11
3.6. DOs Wiring and Characteristics .....	11
3.7. DIs Wiring.....	12
4. Parameters Setup.....	13
4.1. Parameters List .....	13
4.2. Parameters Description.....	16
ⓄAddress 100, Server Synchronal Flag.....	16
ⓄAddress 101, Real-Time X Axis Acceleration .....	16
ⓄAddress 102, Real-Time Y Axis Acceleration .....	16
ⓄAddress 103, Real-Time Z Axis Acceleration .....	16
ⓄAddress 104, Real-Time Vector Acceleration .....	16
ⓄAddress 105, X Axis Offset.....	16
ⓄAddress 106, Y Axis Offset.....	17
ⓄAddress 107, Z Axis Offset .....	17
ⓄAddress 108, Maximum Vector in Earthquake .....	17
ⓄAddress 109, Real-Time Earthquake Intensity .....	17
ⓄAddress 110, Maximum Intensity in the last Earthquake.....	17
ⓄAddress 111, Earthquake Indicator.....	18
ⓄAddress 112, LTA Ready Indicator .....	18
ⓄAddress 113, Setup Parameters.....	18
ⓄAddress 114, Time Zone.....	18
ⓄAddress 115, STA Duration .....	18
ⓄAddress 116, LTA Duration .....	19
ⓄAddress 117, Earthquake Threshold in STA/LTA .....	19
ⓄAddress 118, GB/T 17742-2008 Mode, DO Control Mode.....	19



©Address 119, DI/Os Status .....	19
©Address 120 , Earthquake Event Duration .....	19
©Address 121 , Period of Offset Calculation .....	20
©Address 122 , Numbers Of Records For Offset Calculation .....	20
©Address 123 , DO0 Activated Setting .....	20
©Address 124 , DO1 Activated Setting .....	20
©Address 128 , Real-Time STA/LTA .....	20
©Address 129 , Maximum X Axis Acceleration In Earthquake .....	20
©Address 130 , Maximum Y Axis Acceleration In Earthquake .....	20
©Address 131 , Maximum Z Axis Acceleration In Earthquake .....	21
©Address132 , Maximum X Axis Acceleration Of Vector In Earthquake .....	21
©Address133 , Maximum Y Axis Acceleration Of Vector In Earthquake .....	21
©Address134 , Maximum Z Axis Acceleration Of Vector In Earthquake .....	21
©Address 136 , Count Down Timer For Offset Calculation .....	21
©Address 141 , Earthquake Time – Year .....	21
©Address 142 , Earthquake Time – Month .....	21
©Address 143 , Earthquake Time – Day .....	21
©Address 144 , Earthquake Time – Hour .....	21
©Address 145 , Earthquake Time – Minute .....	22
©Address 146 , Earthquake Time – Second .....	22
©Address 147 , System Time – Year .....	22
©Address 148 , System Time – Month .....	22
©Address 149 , System Time – Day .....	22
©Address 150 , System Time – Hour .....	22
©Address 151 , System Time – Minute .....	22
©Address 152 , System Time – Second .....	22
©Address 153 , Set System Time – Year .....	22
©Address 154 , Set System Time – Month .....	22
©Address 155 , Set System Time – Day .....	22
©Address 156 , Set System Time – Hour .....	23
©Address 157 , Set System Time – Minute .....	23
©Address 158 , Set System Time – Second .....	23
©Address 165 , Calibration Factor for X Axis at 0 g .....	23
©Address 166 , Calibration Factor for Y Axis at 0 g .....	23
©Address 167 , Calibration Factor for Z Axis at 0 g .....	24
©Address 168 , Calibration Factor for X Axis at 1 g .....	24
©Address 169 , Calibration Factor for Y Axis at 1 g .....	24
©Address 170 , Calibration Factor for Z Axis at 1 g .....	25



©Address 171~174 , NTP Server IP .....	25
©Address 175 , Weekday.....	25
©Address 176~179 , Modbus TCP Server IP.....	25
©Address 180~191 , GST-43-M Network Address Setting.....	26
©Address 192 , Available Connections for Host .....	26
©Address 193 , Streaming Control.....	26
©Address 199 , GST-43-M Firmware Number .....	28
©Address 200 , GST-43-M Serial Number .....	28
4.3. Modbus Related Information for GST-43-M .....	28
4.4. GST-43-M Operation Time Sequence .....	29
4.4.1. Power ON Time Sequence.....	29
4.4.2. Parameter Setting Time Sequence .....	29
4.4.3. Initialization Time Sequence .....	30
4.4.4. Earthquake Time Sequence.....	30
Appendix 1. Earthquake Intensity Table, Central Weather Bureau, Taiwan. ....	31



Revisions		
Date	Description	Author
20100621	The first edition 1.00	Josh



## 1. Features

GST-43-M is an advanced technology seismic switch, including tri-axial MEMS accelerometer, a powerful 16 Bit 80 MHz industrial CPU. The MEMS accelerometer acquired vibration signal by 100 Hz sampling rate. The CPU filters this vibration signal with digital low pass filter to minimize non-earthquake signal which is above 20 Hz.

GST-43-M adopts STA/LTA algorithm and dynamic zero offset to detect earthquake. This kind of algorithm is very useful to eliminate none earthquake vibration but in the other hand, with high sensitivity in the same time. GST-43-M is not only a seismic switch but also an earthquake intensity indicator. It could real time display maximum intensity according to CWB (Central Weather Bureau, Taiwan) or GB/T 17742-2008 (China) earthquake intensity standard, maximum vector, tri-axial acceleration and instant tri-axial acceleration...etc. User can preset acceleration threshold for 2 digital outputs individually in order to protect crucial facilities.

Support NTP (Network Time Protocol) for time calibration to keep GST-43-M clock on time. It is also possible to record earthquake vibration data via network by PC utility. The open connectivity of GST-43-M offers Modbus RTU / TCP protocol so it is very easy to connect with PC, PLC, HMI (Human Machine Interface) and SCADA. The connection number of hosts can be up to 3 simultaneously. So it is very simple to connect with broadcast, disaster prevention system. It also provides active connection to TCP server ability which is useful to deploy at environment with no real IP.

## 2. Application Architecture

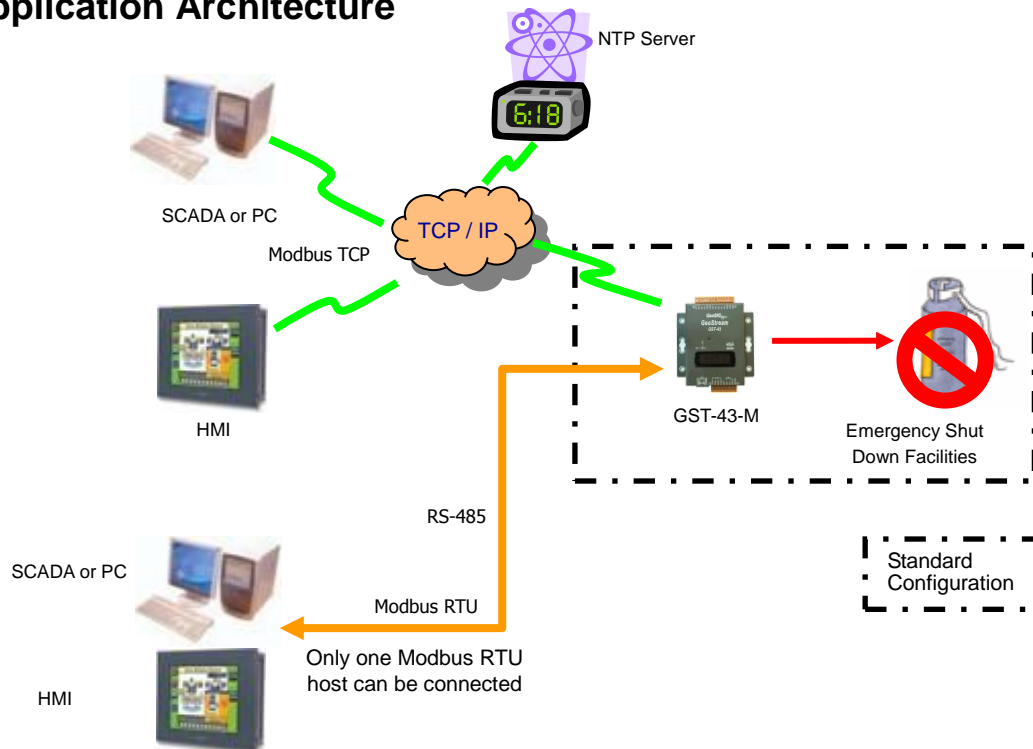

### 3. Wiring

#### 3.1. Wiring

Pin NO	Pin Definition	Description
E1	E1	Modbus TCP (10 / 100M Ethernet Port)
1	CTS1	COM1 CTS
2	RTS1	COM1 RTS
3	RxD1	COM1 Rx
4	TxD1	COM1 Tx
5	INIT*	For Service only. Please do not connect.
6	D2+	COM2, Modbus RTU (RS-485 D+)
7	D2-	COM2, Modbus RTU (RS-485 D-)
8	(R)+Vs	Power 10 ~ 30 VDC 300mA
9	(B)GND	Power Ground
10 - 12	GND	Signal Ground
13	DI0	Digital Input 0 (LED display will show IP when grounding)
14	DI1	Digital Input 1 (LED display will show Last Event Inform when grounding)
15	DI2	Digital Input 2 (RTD Output Mode)
16	DI3	Digital Input 3 (Reserved)
17、20、21	N/A	Internally not connected
18	DO0+	Relay Output 0+ (Photo MOS Relay, Form A) Normal Open , 0.6A/60VDC
19	DO0-	Relay Output 0- (Photo MOS Relay, Form A) Normal Open , 0.6A/60VDC
22	DO1+	Relay Output 1+ (Photo MOS Relay, Form A) Normal Open , 0.6A/60VDC
23	DO1-	Relay Output 1- (Photo MOS Relay, Form A) Normal Open , 0.6A/60VDC



## 3.2. Information for Power LED and 7 Segment LED Display

### ◎Power LED

It will light up for 5 seconds after power on and goes off during LTA calculating. Blink after LTA calculation finish and which means GST-43-M is ready to detect earthquake. Stop blink and light up when earthquake is detected. Light off after earthquake event finish.

### ◎7 Segment LED Display

#### Normal Status

Display will illustrate three kinds of information periodically which are “YYYY.MM.DD WWW”, “hh.mm” and “.ss.”. It will blink if NTP synchronal function is enabled and GST-43-M is unable to synchronize with NTP server.

YYYY : Year  
MM : Month  
DD : Day  
WWW : Weekday  
hh : Hour  
mm : Minute  
ss : Second

#### Earthquake Detected

Display will illustrate two kinds of information periodically which are maximum intensity and maximum acceleration. If GST-43-M is configured as CWB intensity based mode then the information is “IIIII” and “VVVV.V”.

I : Maximum Intensity  
VVVV.V : Maximum Acceleration in mg Unit

If GST-43-M is configured as GB/T 17742-2008 intensity based mode then the information is “I” and “VV.VVV”

I : Maximum Intensity  
VV.VVV : Maximum Horizontal Acceleration in m/sec<sup>2</sup> Unit

## 3.3. Digital Inputs Configurations

### ◎ Reset to Factory Setting

GST-43-M will restore all parameters to factory default setting if all four DIs are grounding.

### ◎ Display IP Information

When DI0 is grounding GST-43-M will display IP information as “XXX.XXX.XXX.XXX” format.



### © Display The Last Earthquake Information

GST-43-M will display the last earthquake information when DI1 is grounding. The display format is described as below.

CWB Intensity Based Mode: “YYYY.MM.DD hh.mm.ss I.I.I.I.I VVVV.V”

- YYYY : Year
- MM : Month
- DD : Day
- hh : Hour
- mm : Minute
- ss : Second
- I : Maximum Intensity
- V : Maximum Acceleration in mg Unit.

GB/T 17742-2008 Based Mode: “YYYY.MM.DD hh.mm.ss II VV.VVV”

- YYYY : Year
- MM : Month
- DD : Day
- hh : Hour
- mm : Minute
- ss : Second
- II : Maximum Intensity
- V : Maximum Horizontal Acceleration in m/sec<sup>2</sup> Unit.

### 3.4. RTD (Real Time Data stream) Output Control

When DI2 is grounding GST-43-M will enable RTD output function. The data format is described as below.

Byte 1	Byte 2	Byte 3	Byte 4	Byte 5	Byte 6	Byte 7	Byte 8
0x0d	a High	a Low	b High	b Low	c High	c Low	0x0a

The data output serial port is determined by “autoexec.bat” file in GST-43-M. The communication protocol is “9600, n, 8, 1”. Please refer to next section for more information about “autoexec.bat”. User must be noticed that all DOs will be controlled by RTD serial port and the data are raw without filtered. The DOs control commands are described as below.

	ON	OFF
DO0	#ON0#\r	#OFF0#\r
DO1	#ON1#\r	#OFF1#\r

\r stands for 0x0d



### 3.5. Parameters for Autoexec.bat

There are five parameters for “autoexec.bat” file for GST-43-M as below.

Example: runexe 2 V S N Y

Parameter 1: Modbus RTU Port

Possible options are 1 or 2. RTD output function will be enabled when DI2 is grounding. The RTD serial port is automatically switched to the other port. For this example, Modbus RTU port is 2 and RTD port is 1.

Parameter 2: CWB Intensity Calculating Base

The possible options are “V” and “N”. “V” means intensity calculating by vector acceleration and “N” means intensity by axes acceleration.

Parameter 3: Automatic Connect to TCP Server

The possible options are “S” and “N”. “S” means enable server connection and “N” means disable.

Parameter 4: DHCP Client Enable

The possible options are “Y” and “N”.

Parameter 5: NTP Enable

The possible options are “Y” and “N”.

Attention! All these five parameters should be maintained by professional with precise setting. Otherwise, it will cause GST-43-M malfunction.

### 3.6. DOs Wiring and Characteristics

DO is acted just like a switch but with contact capacity as 60V 0.6A. Please refer to wiring diagram as below.

Output Type	Readback as 1	Readback as 0
	Relay On	Relay Off
From A Relay Contact		

### 3.7. DIs Wiring

Please refer to DI wiring diagram as below.

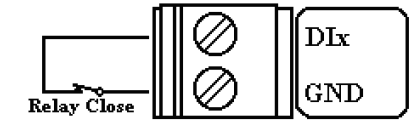
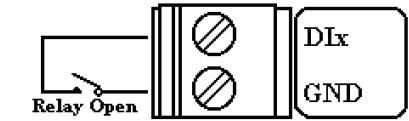
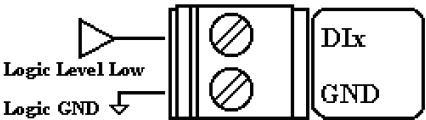
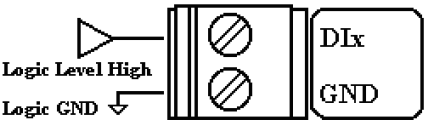
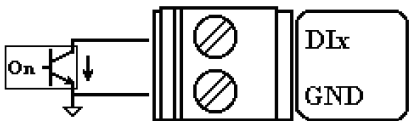
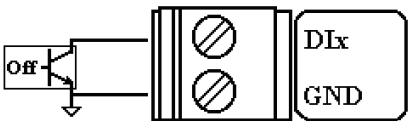
Input Type	ON State DI value as <b>1</b>	OFF State DI value as <b>0</b>
Relay Contact		
TTL/CMOS Logic		
Open Collector		



## 4. Parameters Setup

The parameters of GST-43-M have been setup optimally. However, due to different installation location and background noise, some adjustments for parameters are necessary. Each function of GST-43-M parameters is described as below.

### 4.1. Parameters List

<b>GST-43-M Modbus Address Mapping Table (400XXX)</b>		
<b>Address</b>	<b>Label</b>	<b>Description</b>
100	sync_flag	Servers Synchronal Indicator
101	x_axis	Real-Time X Axis Acceleration
102	y_axis	Real-Time Y Axis Acceleration
103	z_axis	Real-Time Z Axis Acceleration
104	vector	Real-Time Vector Acceleration
105	x_offset	X Axis Offset
106	y_offset	Y Axis Offset
107	z_offset	Z Axis Offset
108	vector_mg_max	Maximum Vector in Earthquake (Unit : mg)
109	intensity_now	Real-Time Earthquake Intensity
110	intensity_max	Maximum Intensity in Earthquake
111	earthquake_event	Earthquake Indicator
112	lta_flag	LTA Ready Indicator (1 as Ready)
113	data_changed	Setup Option (2 as Write to EEPROM, 4 as Write IP Address Setting to EEPROM, 8 as Update System Time)
114	time_diff	GMT Time Zone (Taipei is 8)
115	sta_time	STA Duration (Unit : 100ms)
116	lta_time	LTA Duration (Unit : 100ms)
117	sta_lta_th	Earthquake Threshold In STA/LTA
118	op_enable	GB/T 17742-2008 Mode, DO Control Mode
119	DIO_status	DI and DO status
120	event_time	Earthquake Event Duration (Unit : Second)
121	offset_period	Period of Offset Calculation (Unit : Minute)
122	offset_records	Numbers of Records for Offset Calculation
123	DO0_mg	DO0 Activated Setting (Unit : mg)
124	DO1_mg	DO1 Activated Setting (Unit : mg)
128	sta_lta	Real-Time STA/LTA

<b>GST-43-M Modbus Address Mapping Table (400XXX)</b>		
129	x_maximum	Maximum X Axis Acceleration in Earthquake
130	y_maximum	Maximum Y Axis Acceleration in Earthquake
131	z_maximum	Maximum Z Axis Acceleration in Earthquake
132	vector_max_x	Maximum X Axis Acceleration of Vector in Earthquake
133	vector_max_y	Maximum Y Axis Acceleration of Vector in Earthquake
134	vector_max_z	Maximum Z Axis Acceleration of Vector in Earthquake
136	offset_min_lap	Count Down Timer for Offset Calculation (Unit : Minute)
141	e_year	Earthquake Time - Year
142	e_month	Earthquake Time – Month
143	e_day	Earthquake Time – Day
144	e_hour	Earthquake Time – Hour
145	e_minute	Earthquake Time – Minute
146	e_second	Earthquake Time - Second
147	sys_year	System Time – Year
148	sys_month	System Time – Month
149	sys_day	System Time – Day
150	sys_hour	System Time – Hour
151	sys_minute	System Time – Minute
152	sys_second	System Time – Second
153	set_year	Set System Time – Year
154	set_month	Set System Time – Month
155	set_day	Set System Time - Day
156	set_hour	Set System Time - Hour
157	set_minute	Set System Time - Minute
158	set_second	Set System Time - Second
165	x_0g	Calibration Factor for X Axis at 0 g (Unit 0.1 mg)
166	y_0g	Calibration Factor for Y Axis at 0 g (Unit 0.1 mg)
167	z_0g	Calibration Factor for Z Axis at 0 g (Unit 0.1 mg)
168	x_1g	Calibration Factor for X Axis at 1 g (Unit 0.1 mg)
169	y_1g	Calibration Factor for Y Axis at 1 g (Unit 0.1 mg)
170	z_1g	Calibration Factor for Z Axis at 1 g (Unit 0.1 mg)
171	ntp_svr_ip1	NTP Server IP Address 1
172	ntp_svr_ip2	NTP Server IP Address 2
173	ntp_svr_ip3	NTP Server IP Address 3



<b>GST-43-M Modbus Address Mapping Table (400XXX)</b>		
174	ntp_svr_ip4	NTP Server IP Address 4
175	week_day	System Time - Weekday
176	server_ip1	Server IP Address 1
177	server_ip2	Server IP Address 2
178	server_ip3	Server IP Address 3
179	server_ip4	Server IP Address 4
180	IP1	GST-43-M IP address
181	IP2	GST-43-M IP address
182	IP3	GST-43-M IP address
183	IP4	GST-43-M IP address
184	Subnet mask 1	GST-43-M IP subnet mask
185	Subnet mask 2	GST-43-M IP subnet mask
186	Subnet mask 3	GST-43-M IP subnet mask
187	Subnet mask 4	GST-43-M IP subnet mask
188	Gateway 1	GST-43-M IP gateway
189	Gateway 2	GST-43-M IP gateway
190	Gateway 3	GST-43-M IP gateway
191	Gateway 4	GST-43-M IP gateway
192	sck_remain	Available Connections for Host
193	streaming_control	Streaming Control
194	rtu_address	GST-43-M Modbus RTU address
199	version	Firmware Number
200	serial_no	GST-43-M Serial Number



## 4.2. Parameters Description

### ◎Address 100, Server Synchronal Flag

#### bit 0

0: GST-43-M not synchronize with NTP server.

1: GST-43-M has synchronized with NTP server. The synchronal interval is 10 minutes and GST-43-M will try to synchronize with NTP server every 10 seconds if last synchronization failed. The new connection will be established if there is no synchronization within 700 seconds.

Regarding the IP address setting for NTP server please refer to addresses 171 to 174.

#### bit 1

0: Indicate that there is no connection with TCP server.

1: Indicate that connection between TCP server and GST-43-M has established.

Regarding the IP address setting for TCP server please refer to addresses 176 to 179.

### ◎Address 101, Real-Time X Axis Acceleration

Real-time X axis acceleration in counts unit, 1 mg is equal to 16.384 counts. The throughput is 100 samples / second when connected up to 3 hosts in Ethernet environment.

### ◎Address 102, Real-Time Y Axis Acceleration

Real-time Y axis acceleration in counts unit, 1 mg is equal to 16.384 counts. The throughput is 100 samples / second when connected up to 3 hosts in Ethernet environment.

### ◎Address 103, Real-Time Z Axis Acceleration

Real-time Z axis acceleration in counts unit, 1 mg is equal to 16.384 counts. The throughput is 100 samples / second when connected up to 3 hosts in Ethernet environment.

### ◎Address 104, Real-Time Vector Acceleration

Real-time vector acceleration in counts unit, 1 mg is equal to 16.384 counts. The throughput is 100 samples / second when connected up to 3 hosts in Ethernet environment. The equation of vector is described as below.

$$Vector = \sqrt{X^2 + Y^2 + Z^2}$$

### ◎Address 105, X Axis Offset

This address stores X offset value which is calculated by GST-43-M during offset calculation.

The unit is count, 1 mg is equal to 16.384 counts.

The output of accelerometer at zero acceleration will be affected by installation or some other



issues. GST-43-M supports dynamic zero and periodic zero.

#### ◎Address 106, Y Axis Offset

This address stores Y offset value which is calculated by GST-43-M during offset calculation.

The unit is count, 1 mg is equal to 16.384 counts.

The output of accelerometer at zero acceleration will be affected by installation or some other issues. GST-43-M supports dynamic zero and periodic zero.

#### ◎Address 107, Z Axis Offset

This address stores Z offset value which is calculated by GST-43-M during offset calculation.

The unit is count, 1 mg is equal to 16.384 counts.

The output of accelerometer at zero acceleration will be affected by installation or some other issues. GST-43-M supports dynamic zero and periodic zero.

#### ◎Address 108, Maximum Vector in Earthquake

The maximum vector acceleration stored in the last earthquake, unit as mg. This value will be updated when next earthquake occurred or will be cleared if GST-43-M gets into initialization mode.

#### ◎Address 109, Real-Time Earthquake Intensity

This address stores real-time intensity as grade from 0 to 7 based on CWB standard (Central Weather Bureau, Taiwan) or from 0 to 11 based on GB/T 17742-2008 standard (China). This number will only meaningful when earthquake indicator (address 111) is set. GST-43-M calculates vector or absolute axes acceleration to determine equivalent earthquake intensity. Please refer to address 118 for related setting.

Due to there is no definition for intensity less equal 4 in GB/T 17742-2008. So GST-43-M uses below levels do determine intensity.

- 1 :  $\leq 0.008 \text{ m/sec}^2$
- 2 :  $\leq 0.022 \text{ m/sec}^2$
- 3 :  $\leq 0.080 \text{ m/sec}^2$
- 4 :  $\leq 0.220 \text{ m/sec}^2$

#### ◎Address 110, Maximum Intensity in the last Earthquake

This address stores the maximum intensity of the last earthquake, unit as grade form 0 to 7 based on CWB standard (Central Weather Bureau, Taiwan) or from 0 to 11 based on GB/T 17742-2008 standard. Please refer to address 118 for detail setting.



#### ◎Address 111, Earthquake Indicator

The value will be 1 when GST-43-M detects earthquake. 0 when there is no earthquake detected.

#### ◎Address 112, LTA Ready Indicator

LTA stands for Long Time Average, which is average of vector in specified long time period. The opposing parameter is STA, which stands for Short Time Average. GST-43-M uses STA/LTA as earthquake detecting algorithm. It will issue earthquake signal when STA divide LTA (address 128) is great than preset value (The factory preset value is 3, address 117). GST-43-M needs enough time to accumulate enough data for LTA calculation. This LTA Ready Indicator will become 1 when GST-43-M LTA buffering is completed. In other word, GST-43-M earthquake detecting algorithm can function only this Indicator is 1.

#### ◎Address 113, Setup Parameters

Write proper value to this address to refresh GST-43-M when change any parameters. The available setup options are described as below.

- 2 - Update and write parameters into EEPROM and force GST-43-M to restart.
- 4 - Update and write GST-43-M its own TCP/IP settings into EEPROM and force GST-43-M to restart.
- 8 - Update and write system clock. GST-43-M will use time information stored in addresses 153 to 158 to update system RTC.

Above setup options 2 and 4 will force GST-43-M gets into initialization. GST-43-M will re-calculate STA, LTA and axes offset compensation at zero. The duration of initialization it takes is determined by address 116, which is LTA duration setting.

#### ◎Address 114, Time Zone

This address stores the GMT time zone information for NTP time calibration, for example, Taipei is GMT + 8. It is no function when NTP service is disabled.

#### ◎Address 115, STA Duration

STA stands for Short Time Average, which is average of vector in specified short time period. The opposing parameter is LTA, which stands for Long Time Average. GST-43-M uses STA/LTA as earthquake event detecting algorithm. It will issue earthquake signal when STA divide LTA (address 128) is great equal to STA/LTA threshold (address 117).

This address represents the duration of STA in 100ms unit. The factory setting of this value is 20 which mean 2 seconds. The larger number the less false trigger is. The maximum value is 1 / 2 of LTA.



### ©Address 116, LTA Duration

LTA stands for Long Time Average, which is average vector in specified long time period. The opposing parameter is STA, which stands for Short Time Average. GST-43-M uses STA/LTA as earthquake event detecting algorithm. It will issue earthquake signal when STA divide LTA (address 128) is great equal to STA/LTA threshold (address 117).

This address represents the duration of LTA in 100ms unit. The factory setting of this value is 800 which mean 80 seconds. The Larger number the sensitive GST-43-M is. The maximum number of LTA is 2000 which mean 200 seconds.

### ©Address 117, Earthquake Threshold in STA/LTA

GST-43-M uses STA/LTA as earthquake detecting algorithm. It will issue earthquake event when STA divide LTA (address 128) is great equal this threshold (The factory preset value is 3).

### ©Address 118, GB/T 17742-2008 Mode, DO Control Mode

bit 0: Intensity calculation standard.

0: CWB (Taiwan) standard.

1: GB/T 17742-2008 (China) standard.

bit 1: DOs control mode

0: Standard DOs control mode. During this mode, The DOs turn on time will be determined by address 120.

1: DOs will only turn on for 2 seconds when earthquake signal is set. This is suitable for gas valve control.

### ©Address 119, DI/Os Status

The DI/Os status will be updated every second. High byte represents DIs and low byte as DOs. There are 4 DIs map from bit 8 to bit 11 and 2 DOs map from bit 0 to bit 1. It is also possible to use Modus DI and DO commands to read these DI/Os status which their addresses are begin from 100.

### ©Address 120 , Earthquake Event Duration

When earthquake is detected (STA divide LTA (address 128) is great equal to STA/LTA threshold (address 117)), GST-43-M will enter earthquake operation mode. Below describe tasks performed during this mode.

- a. Earthquake Indicator will be set to 1 (Address 111).
- b. Maximum acceleration, intensity and time will be update and store in real-time.



- c. Determining of turn-on or turn-off for both two DOs.
- d. Counting down the earthquake event duration timer. Timer will be reset if maximum acceleration occurred. GST-43-M will return to normal operation mode when time is up. This address stores the timer value in second (The factory preset value is 30).

**©Address 121 › Period of Offset Calculation**

GST-43-M has two mechanisms for offset calculation. They are periodical and dynamic offset calculation. The address here stores the time in minutes for periodical offset calculation (The factory preset value is 1440).

**©Address 122 › Numbers Of Records For Offset Calculation**

This address stores the number of records to be averaged for offset calculation (The factory preset value is 200). Please refer to “Address 121, Period of Offset Calculation”.

**©Address 123 › DO0 Activated Setting**

This address stores the activated acceleration threshold of DO0, unit in mg. DO0 will be turn-on when vector acceleration is great equal this setting while earthquake. And it will on continually while earthquake indicator is 1 (address 111).

**©Address 124 › DO1 Activated Setting**

This address stores the activated acceleration threshold of DO1, unit in mg. DO1 will be turn-on when vector acceleration is great equal this setting while earthquake. And it will on continually while earthquake indicator is 1 (address 111).

**©Address 128 › Real-Time STA/LTA**

GST-43-M uses STA/LTA algorithm to detect earthquake. This address contains the real-time STA/LTA value. Earthquake indicator (address 1) will be set to 1 when this value is great equal “Earthquake Threshold in STA/LTA, address 117”.

**©Address 129 › Maximum X Axis Acceleration In Earthquake**

GST-43-M will store the information for maximum acceleration. This address stores the maximum acceleration in X axis during the last earthquake, unit in count. One mg is equal to 16.384 counts.

**©Address 130 › Maximum Y Axis Acceleration In Earthquake**

GST-43-M will store the information for maximum acceleration. This address stores the maximum acceleration in Y axis during the last earthquake, unit in count. One mg is equal to 16.384 counts.



©**Address 131** › **Maximum Z Axis Acceleration In Earthquake**

GST-43-M will store the information for maximum acceleration. This address stores the maximum acceleration in Z axis during the last earthquake, unit in count. One mg is equal to 16.384 counts.

©**Address132** › **Maximum X Axis Acceleration Of Vector In Earthquake**

GST-43-M will store the information for maximum acceleration. This address stores the X component acceleration in maximum vector during the last earthquake, unit in count. One mg is equal to 16.384 counts.

©**Address133** › **Maximum Y Axis Acceleration Of Vector In Earthquake**

GST-43-M will store the information for maximum acceleration. This address stores the Y component acceleration in maximum vector during the last earthquake, unit in count. One mg is equal to 16.384 counts.

©**Address134** › **Maximum Z Axis Acceleration Of Vector In Earthquake**

GST-43-M will store the information for maximum acceleration. This address stores the Z component acceleration in maximum vector during the last earthquake, unit in count. One mg is equal to 16.384 counts.

©**Address 136** › **Count Down Timer For Offset Calculation**

The Address indicates the minutes left for periodical offset calculation. Please refer to “Address 121 › Period of Offset Calculation”.

©**Address 141** › **Earthquake Time – Year**

This address stores the last earthquake happened time, year.

©**Address 142** › **Earthquake Time – Month**

This address stores the last earthquake happened time, month.

©**Address 143** › **Earthquake Time – Day**

This address stores the last earthquake happened time, day.

©**Address 144** › **Earthquake Time – Hour**

This address stores the last earthquake happened time, hour.



◎ **Address 145** , **Earthquake Time – Minute**

This address stores the last earthquake happened time, minute.

◎ **Address 146** , **Earthquake Time – Second**

This address stores the last earthquake happened time, second.

◎ **Address 147** , **System Time – Year**

This address indicates the GST-43-M system time, year.

◎ **Address 148** , **System Time – Month**

This address indicates the GST-43-M system time, month.

◎ **Address 149** , **System Time – Day**

This address indicates the GST-43-M system time, day.

◎ **Address 150** , **System Time – Hour**

This address indicates the GST-43-M system time, hour.

◎ **Address 151** , **System Time – Minute**

This address indicates the GST-43-M system time, minute.

◎ **Address 152** , **System Time – Second**

This address indicates the GST-43-M system time, second.

◎ **Address 153** , **Set System Time – Year**

Although GST-43-M embedded with NTP function, user still could use address 153 to 158 to set system time. This address stores the information for set system time, which is year.

GST-43-M will update its RTC (system time) by taking time information stored in address 153 to 158 when address 113 is set to 8.

◎ **Address 154** , **Set System Time – Month**

Although GST-43-M embedded with NTP function, user still could use address 153 to 158 to set system time. This address stores the information for set system time, which is month.

GST-43-M will update its RTC (system time) by taking time information stored in address 153 to 158 when address 113 is set to 8.

◎ **Address 155** , **Set System Time – Day**

Although GST-43-M embedded with NTP function, user still could use address 153 to 158 to



set system time. This address stores the information for set system time, which is day. GST-43-M will update its RTC (system time) by taking time information stored in address 153 to 158 when address 113 is set to 8.

©**Address 156** › **Set System Time – Hour**

Although GST-43-M embedded with NTP function, user still could use address 153 to 158 to set system time. This address stores the information for set system time, which is hour. GST-43-M will update its RTC (system time) by taking time information stored in address 153 to 158 when address 113 is set to 8.

©**Address 157** › **Set System Time – Minute**

Although GST-43-M embedded with NTP function, user still could use address 153 to 158 to set system time. This address stores the information for set system time, which is minute. GST-43-M will update its RTC (system time) by taking time information stored in address 153 to 158 when address 113 is set to 8.

©**Address 158** › **Set System Time – Second**

Although GST-43-M embedded with NTP function, user still could use address 153 to 158 to set system time. This address stores the information for set system time, which is second. GST-43-M will update its RTC (system time) by taking time information stored in address 153 to 158 when address 113 is set to 8.

©**Address 165** › **Calibration Factor for X Axis at 0 g**

GST-43-M is calibrated at factory already, so it is not recommend user to change these calibration factors stored in address 165 to 170.

Address 165 stores the zero g calibration factor for X axis. Below describe the calibration procedure.

- a. Align GST-43-M X axis horizontally.
- b. Write 0 to this address and force GST-43 into initiation.
- c. Find out X axis offset value and write this value by 10 times. For example, write 102 into this address if offset value is 10.2 mg.
- d. Check if offset value is near by 0.

Caution! Any change of this address may trigger earthquake signal, so please make sure GST-43-M disconnect with other system before you make above procedure.

©**Address 166** › **Calibration Factor for Y Axis at 0 g**

GST-43-M is calibrated at factory already, so it is not recommend user to change these calibration factors stored in address 165 to 170.



Address 166 stores the zero g calibration factor for Y axis. Below describe the calibration procedure.

- a. Align GST-43-M Y axis horizontally.
- b. Write 0 to this address and force GST-43-M into initiation.
- c. Find out Y axis offset value and write this value by 10 times. For example, write 102 into this address if offset value is 10.2 mg.
- d. Check if offset value is near by 0.

Caution! Any change of this address may trigger earthquake signal, so please make sure GST-43-M disconnect with other system before you make above procedure.

#### ©Address 167 › Calibration Factor for Z Axis at 0 g

GST-43-M is calibrated at factory already, so it is not recommend user to change these calibration factors stored in address 165 to 170.

Address 167 stores the zero g calibration factor for Z axis. Below describe the calibration procedure.

- a. Align GST-43-M Z axis horizontally.
- b. Write 0 to this address and force GST-43-M into initiation.
- c. Find out Z axis offset value and write this value by 10 times. For example, write 102 into this address if offset value is 10.2 mg.
- d. Check if offset value is near by 0.

Caution! Any change of this address may trigger earthquake signal, so please make sure GST-43-M disconnect with other system before you make above procedure.

#### ©Address 168 › Calibration Factor for X Axis at 1 g

GST-43-M is calibrated at factory already, so it is not recommend user to change these calibration factors stored in address 165 to 170.

Address 168 stores the 1g calibration factor for X axis. Below describe the calibration procedure.

- a. Align GST-43-M X axis vertically.
- b. Write 10000 to this address and force GST-43-M into initiation.
- c. Find out X axis real-time value and write this value by 10 times. For example, write 10208 into this address if offset value is 1020.8 mg.
- d. Check if real-time value is near by 1 g.

Caution! Any change of this address may trigger earthquake signal, so please make sure GST-43-M disconnect with other system before you make above procedure.

#### ©Address 169 › Calibration Factor for Y Axis at 1 g

GST-43-M is calibrated at factory already, so it is not recommend user to change these



calibration factors stored in address 165 to 170.

Address 169 stores the 1g calibration factor for Y axis. Below describe the calibration procedure.

- a. Align GST-43-M Y axis vertically.
- b. Write 10000 to this address and force GST-43-M into initiation.
- c. Find out Y axis real-time value and write this value by 10 times. For example, write 10208 into this address if offset value is 1020.8 mg.
- d. Check if offset value is near by 1 g.

Caution! Any change of this address may trigger earthquake signal, so please make sure GST-43-M disconnect with other system before you make above procedure.

#### ©Address 170 › Calibration Factor for Z Axis at 1 g

GST-43-M is calibrated at factory already, so it is not recommend user to change these calibration factors stored in address 165 to 170.

Address 170 stores the 1g calibration factor for Z axis. Below describe the calibration procedure.

- a. Align GST-43-M Z axis vertically.
- b. Write 10000 to this address and force GST-43-M into initiation.
- c. Find out Z axis real-time value and write this value by 10 times. For example, write 10208 into this address if offset value is 1020.8 mg.
- d. Check if offset value is near by 1 g.

Caution! Any change of this address may trigger earthquake signal, so please make sure GST-43-M disconnect with other system before you make above procedure.

#### ©Address 171~174 › NTP Server IP

GST-43-M embedded with NTP function which could calibrate its system time via network time server. These addresses store NTP server IP information (Factory preset value is 192.43.244.18 which is time.nist.gov).

When these addresses are changed user must also write 2 into address 113 to effect the changes.

#### ©Address 175 › Weekday

This address indicates the weekday of GST-43-M system time. The number is from 1 to 6 stands for Monday to Saturday, 7 for Sunday.

#### ©Address 176~179 › Modbus TCP Server IP

GST-43-M has ability to connect with server automatically. This is an advantage for GST-43-M at the site without real IP. When Modbus TCP server was connected by GST-43-M, It will



receive ASCII serial number of GST-43-M in order to be identified by the server.

These addresses store Modbus Server IP information. User must write 2 into address 113 to effect the changes (The factory preset value is 192.168.255.2).

Regarding how to enable the TCP server connection please refer to the parameters for “autoexec.bat” file.

#### ©Address 180~191 › GST-43-M Network Address Setting

These addresses store IP information of GST-43-M. User must write 4 into address 113 to effect the changes.

The factory preset values are described as below.

IP: 192.168.255.1

Mask: 255.255.0.0

Gateway: 192.168.0.1

#### ©Address 192 › Available Connections for Host

GST-43-M offer 3 TCP connections for host simultaneously. This address indicates remain connections.

#### ©Address 193 › Streaming Control

GST-43-M will stream data packet every two seconds when this address is changed to 1 via Modbus TCP protocol. This is very useful when user wants to have recording function by network. Write 0 to this address to stop the streaming. Below describe the content of the streaming data packet.



Integer No.	Description	Remark
1	Synchronal Character 0x30	
1	Synchronal Character 0x33	
2	Synchronal Character 0x30	
2	Synchronal Character 0x35	
3	Synchronal Character 0x31	
3	Synchronal Character 0x35	
4	Synchronal Character 0x30	
4	Synchronal Character 0x31	
5	Year	Event time will be replaced when earthquake is detected.
6	Month	
7	Day	
8	Hour	
9	Minute	
10	Second(High Byte), 10ms(Low Byte)	
11	Event Flag	
12	Maximum Intensity	
13	Current Intensity	
14	X axis Acceleration of Record 1	
15	Y axis Acceleration of Record 1	
16	Z axis Acceleration of Record 1	
..	..	
1224	X axis Acceleration of Record 200	
1225	Y axis Acceleration of Record 200	
1226	Z axis Acceleration of Record 200	

Remark:

1. Integer format is low byte at first and follow by high byte.
2. Host will get above data packet every 2 seconds when GST-43-M received "01 02 00 00 00 06 01 06 00 C0 00 01" command.



©Address 199 › GST-43-M Firmware Number

This address indicates the firmware version of GST-43-M.

©Address 200 › GST-43-M Serial Number

This Address stores the serial number of GST-43-M. User could change this serial number based on the application needed. The possible range is from 1 to 65535.

GST-43-M will send serial number in ASCII format first via TCP connection when server connection is enabled.

### 4.3. Modbus Related Information for GST-43-M

GST-43-M supports Modbus TCP and Modbus RTU simultaneously. ID will be 1 when connected by Modbus TCP. The Modbus RTU communication parameters is “19200, n, 8, 1”. GST-43-M supports Modbus function 1, 2, 3, 6 and 16.

Example: Set STA as 2.5 seconds by using Modbus TCP.

2.5 seconds equal to 25 \* 0.1 seconds, 25 = 0x0019. Function code is 6 and the register address is 114 = 0x0072 (GST-43-M uses zero based system). The command set will be like this one as below.

TID (hex)	PID (hex)	Field Length (hex)	UID (hex)	FC (hex)	Reg_Offset. (hex)	Value (hex)
0001	0000	0006	01	06	0072	0019

TID: Transaction Identifier;

PID: Protocol Identifier (Protocol Length);

UID: Unit Identifier;

FC: Function Code

## 4.4. GST-43-M Operation Time Sequence

### 4.4.1. Power ON Time Sequence

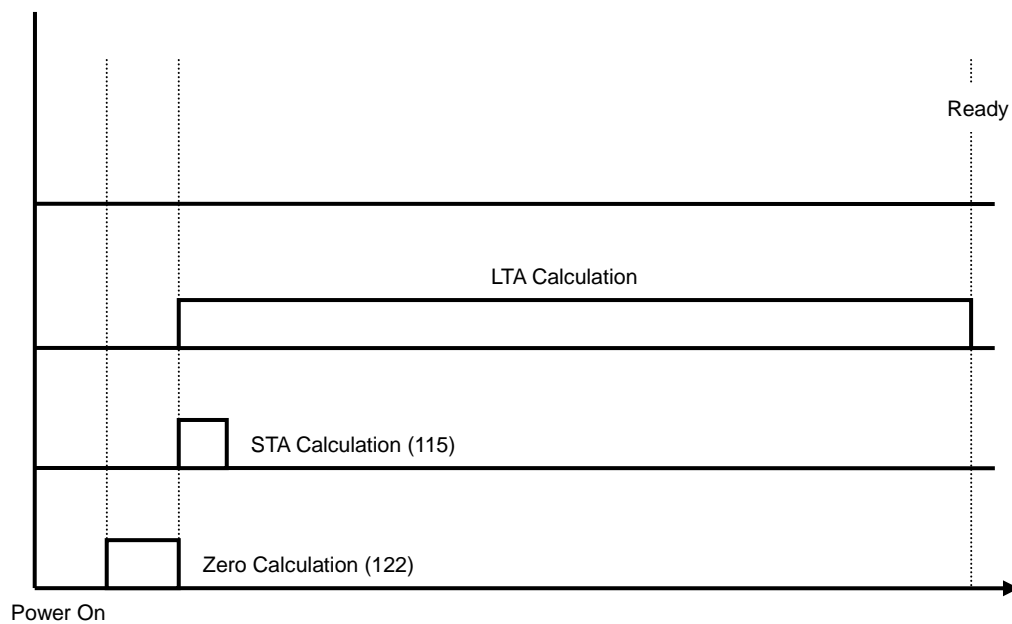

### 4.4.2. Parameter Setting Time Sequence

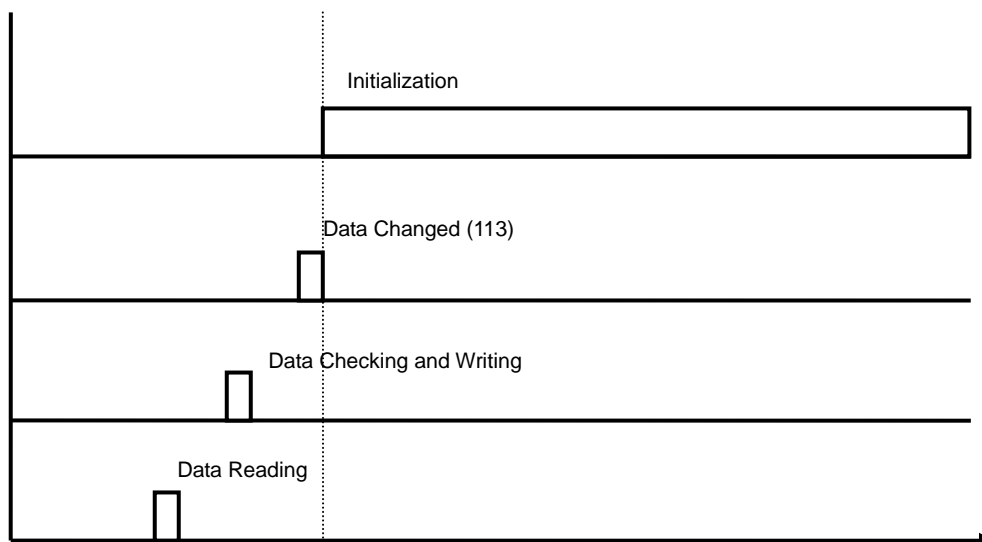

#### 4.4.3. Initialization Time Sequence

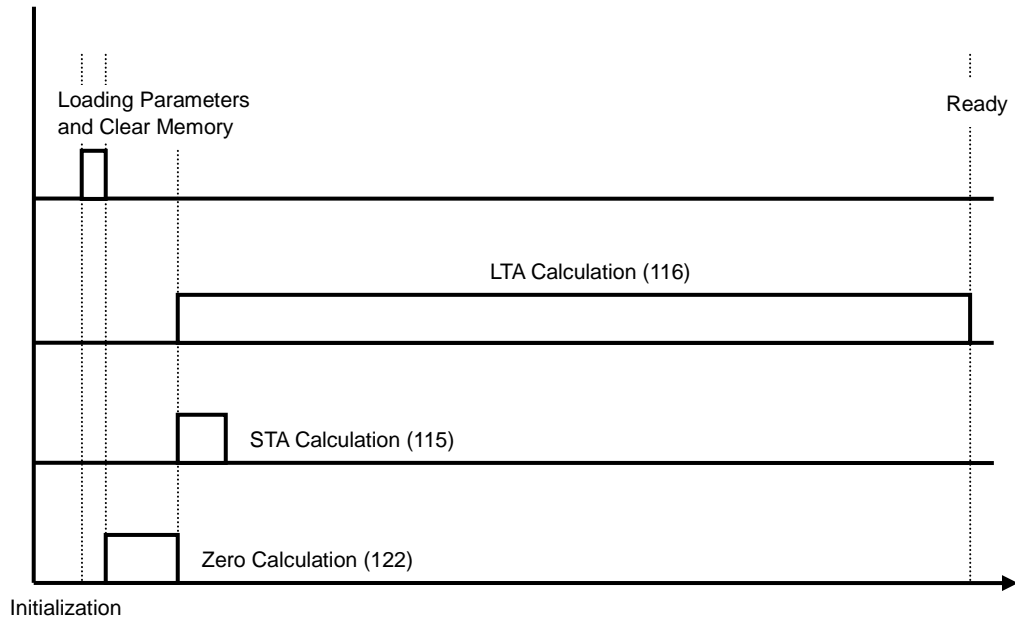

#### 4.4.4. Earthquake Time Sequence

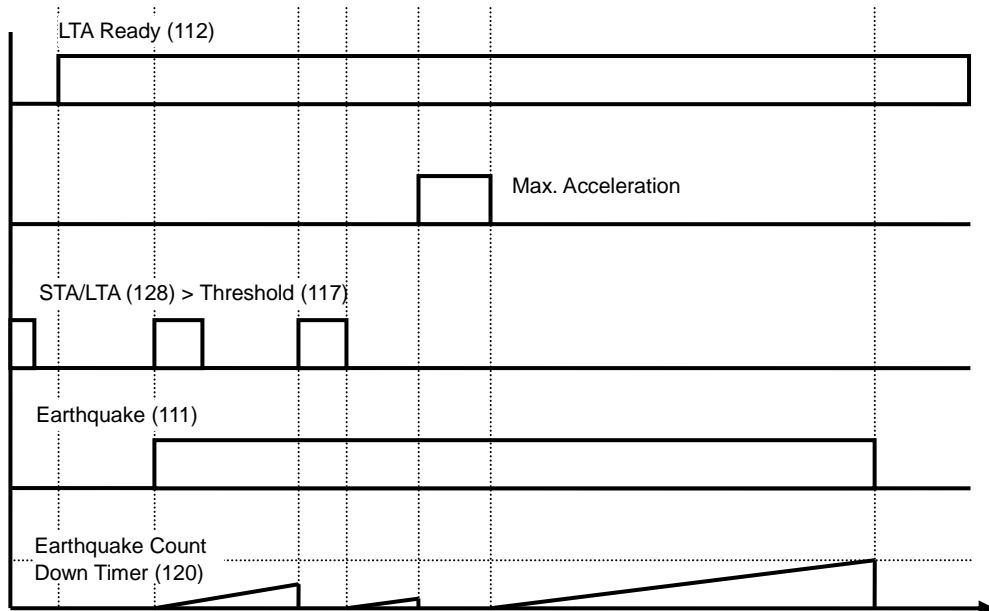



## Appendix 1. Earthquake Intensity Table, Central Weather Bureau, Taiwan.

Intensity Scale		Range of Ground Acceleration	Effects on People	Effects Indoors	Effects Outdoors
1	Very minor	0.8~2.5gal	Felt only by a few people at rest, vibrates slightly.		
2	Minor	2.5~8.0gal	Felt by the majority of people. Some awakened from sleeping.	Hanging lamps and objects vibrate slightly.	Standing vehicles vibrate slightly, similar to being passed by a truck, but only lasts for a short time.
3	Light	8~25gal	Felt by nearly everyone, a few frightened.	Buildings shake; dishes, windows, and doors shake making sounds; hanging objects shake visibly.	Standing vehicles vibrate obviously; electric wires sway gently.
4	Moderate	25~80gal	Many people are quite frightened, looking for safe shelter. Most people are awakened from sleep.	Buildings rock noticeably; unstable objects topple over; heavy furniture moves; may cause slight damage.	Felt by drivers; electric wires sway obviously, felt by people walking.
5	Strong	80~250gal	Most people are considerably frightened.	Walls crack; heavy furniture may overturn.	Noticeably felt by drivers; some chimneys and large archways topple over.
6	Very Strong	250~400gal	People have trouble walking due to violent rocking.	Damage to some buildings; heavy furniture overturns; doors and windows bend.	Drivers have trouble steering; sand and clay blasts occur.
7	Great	400gal and above	People move with difficulty due to severe rocking.	Severe damage to or collapse of some buildings; almost all furniture moves or falls down.	Landslides and faults rupture occur; railway bend; underground lines break.

Note: 1gal = 1cm/sec\*sec, 1g = 980 gal, 1mg = 0.98gal