

Remote I/O



ETS-8KP4



I-8KW & I-87KW



Secure Access

High-Speed DAQ

Multi-Function I/O

RS-485 I/O Products
Ethernet I/O Products
USB I/O Products



ETS-7200



Contents

1	RS-485 I/O Products	P 4
	<ul style="list-style-type: none"> ● 1.1 I-7000 and M-7000 I/O Modules - - - - - P 6 ● 1.2 M-2000 Slim-Type I/O Modules - - - - - P 20 ● 1.3 tM Tiny-Size I/O Modules - - - - - P 23 ● 1.4 RU-87Pn I/O Expansion Units - - - - - P 24 	
2	Secure Ethernet I/O Products	P 26
	<ul style="list-style-type: none"> ● 2.1 ETS-7200 Secure Ethernet I/O Modules - - - - - P 27 ● 2.2 ETS-8KPn Secure Ethernet I/O Expansion Units - - - - - P 34 ● 2.3 U-7500M OPC UA I/O Modules - - - - - P 40 	
3	High-Speed Ethernet I/O Products	P 45
	<ul style="list-style-type: none"> ● 3.1 PET-7H16M/7H24M High-Speed DAQ Modules - - - - - P 46 ● 3.2 DAS-8000 High-Speed Ethernet DAQ System - - - - - P 56 	
4	Ethernet I/O Products	P 63
	<ul style="list-style-type: none"> ● 4.1 (P)ET-7x00 Ethernet Modbus TCP I/O Modules- - - - - P 65 ● 4.2 (P)ET-2200 Slim-Type Modbus TCP I/O Modules - - - - - P 72 ● 4.3 tET/tPET Tiny-Size Modbus TCP I/O Modules - - - - - P 77 ● 4.4 MQ-7200M MQTT I/O Modules - - - - - P 81 	
5	PAC & PAC I/O Modules	P 86
	<ul style="list-style-type: none"> ● 5.1 ET-8KPn-MTCP Series I/O Expansion Units - - - - - P 87 ● 5.2 I-8KW and I-87KW I/O Modules - - - - - P 93 	
6	USB I/O Products	P 101
	<ul style="list-style-type: none"> ● 6.1 USB-2000 and USB-2200 I/O Modules - - - - - P 104 ● 6.2 USB-4000 I/O Modules - - - - - P 108 ● 6.3 USB-87Pn I/O Expansion Units - - - - - P 110 	
7	Related Products	P 112
	<ul style="list-style-type: none"> ● 7.1 EtherCAT I/O Modules - - - - - P 113 ● 7.2 Fieldbus I/O Products - - - - - P 117 ● 7.3 Wireless I/O Products - - - - - P 133 	

Overview

ICP DAS launches a series of remote I/O modules and I/O expansion units for industrial monitoring and controlling applications, various communication interfaces are available for PAC, PC and PLC, such as RS-485, Ethernet, EtherCAT, EtherNet/IP, Profinet, FRnet, CAN bus, Profibus and Hart.



More than 300 modules for choice







1

RS-485 I/O Products

- 1.1 I-7000 and M-7000 I/O Modules - - - - - P 6
- 1.2 M-2000 Slim-Type I/O Modules - - - - - P 20
- 1.3 tM Tiny-Size I/O Modules - - - - - P 23
- 1.4 RU-87Pn I/O Expansion Units - - - - - P 24

RS-485 is a popular choice for industrial automation. It supports long distance communication up to 1.2 km (4000 ft). It uses differential signals to minimize interference and ensure reliable communications. Our RS-485 I/O module provides analog I/O, digital I/O, relay outputs, counters, timers, and more. It supports DCON and Modbus RTU/ASCII protocols for easy integration with SCADA and HMI software.

Product Line	tM series	I-7000	M-7000	M-2000
Pictures				
Page	P.23	P.6	P.6	P.20
Communication				
Protocol	DCON, Modbus RTU, Modbus ASCII	DCON	DCON, Modbus RTU	
Data Format	(N, 8, 1), (N, 8, 2), (O, 8, 1), (E, 8, 1)	(N,8,1)		(N, 8, 1), (N, 8, 2), (O, 8, 1), (E, 8, 1)
Max. Nodes	32	256		
Bias resistor	Yes, 10 KΩ	No (Note1)		
Dual Watchdog	Yes, Module (2.3 second), Communication (Programmable)	Yes, Module (1.6 second), Communication (Programmable)		
I/O				
DIO max. channel	8	16		16
AIO	Resolution	12/14 bits	12/16 bits	
	Max. channel	8 (tM-AD8)	20 (I-7017Z, M-7017Z)	
	Individual Channel Configuration	-	Yes	
Display				
Power and Communication LED	Yes			
I/O Status LED	-	Yes (for D version only)		-
7-Segment LED	-	Yes (for D version only)		-
Mechanical				
Dimensions (W × L × H)	52 × 98 × 27 mm	72 × 123 × 35 mm		33 × 117 × 88 mm 31 × 157 × 132 mm 33 × 110 × 96 mm 33 × 176 × 130 mm
Note1: To ensure stable communication, the RS-485 master must have bias resistors. You can also install a tM-SG4 or SG-785 device for this purpose. All ICP DAS controllers and converters provide the necessary bias.				

Furthermore, we developed the RU-87Pn series, an RS-485 remote I/O unit designed for compact and modular I/O expansion. Its reliable 3-piece construction allows modules to be hot-swapped during operation without rewiring. Each module stores its own configuration while also backing up parameters to the RU-87Pn's non-volatile memory, ensuring automatic recovery after module replacement.



Features:

- Hot Swap
- Auto Configuration
- Easy Duplicate System
- Easy Maintenance and Diagnosis
- DCON Protocol

1.1 I-7000 and M-7000 I/O Modules



The product line includes sensor-to-computer interfaces, computer-to-sensor interfaces, digital I/O modules, timer/counter modules, RS-232 to RS-485 converters, USB to RS-485 converters, RS-485 repeaters, RS-485 hubs, and RS-232/422/485 to Fiber Optic converters. The I-7000 series supports DCON protocol, while M-7000 modules support both Modbus RTU and DCON, ensuring broad compatibility across industrial networks.

These modules simplify installation, enhance flexibility, and enable reliable long-distance communication, making them ideal for integrating legacy devices with modern systems in industrial automation, remote monitoring, and control.

Applications:

Solar energy system, Internet of Things, Industrial 4.0 .

Features:

❖ I/O type and Range Programmable

The analog modules support several types and ranges which can be selected remotely by issuing command from the host.

❖ Dual Watchdog with Power-on and Safe Values

To ensure system reliability, stability, and continuous operation, this module incorporates a Dual Watchdog design. The hardware watchdog automatically resets the MCU if it detects a module freeze, preventing it from stopping working. This reset loads the AO/DO values according to user-defined power-on settings. The software watchdog monitors communication activity between the host controller and the module. If the watchdog timeout occurs, the module switches its outputs to predefined safe values to prevent incorrect operation.

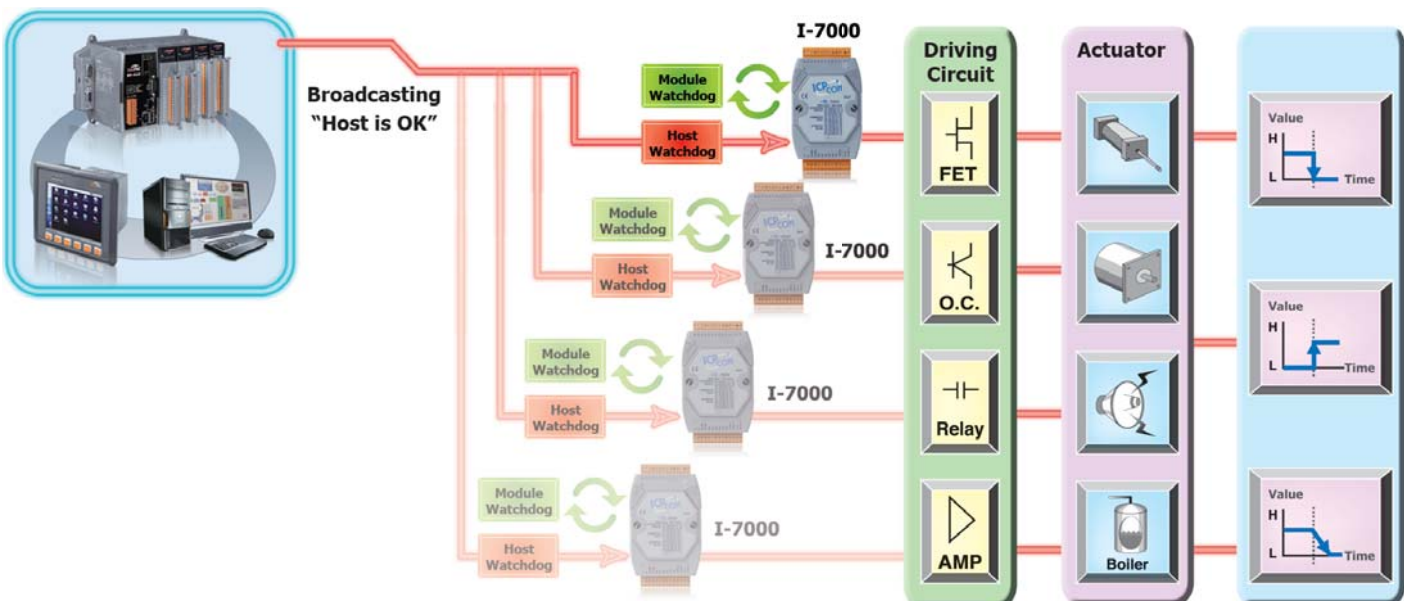

❖ Advanced DI Functions

DI channel is not only for reading digital input status but also provides several advanced functions in the meanwhile.

● DI latch Function

Rapid DI status changes may be lost when the host polls each module individually. The DI latch function stores high/low events in the module's internal registers, ensuring short-duration signals (≥ 5 ms) are reliably captured without data loss.

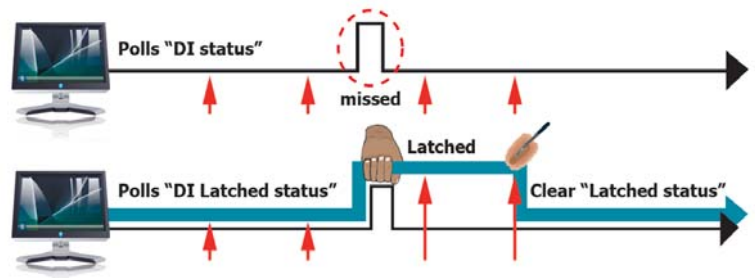

● 16-bit Counter

The DI module automatically monitors and counts DI signals in the background, reliably detecting and processing signals below 100 Hz. This ensures real-time data acquisition without manual intervention, improving efficiency and accuracy in low-frequency signal measurement applications.



❖ Overvoltage Protection

Most of our analog input modules feature high overvoltage protection on all input channels. This safeguard enhances system reliability, minimizes maintenance needs, and ensures robust operation—even in harsh electrical environments.

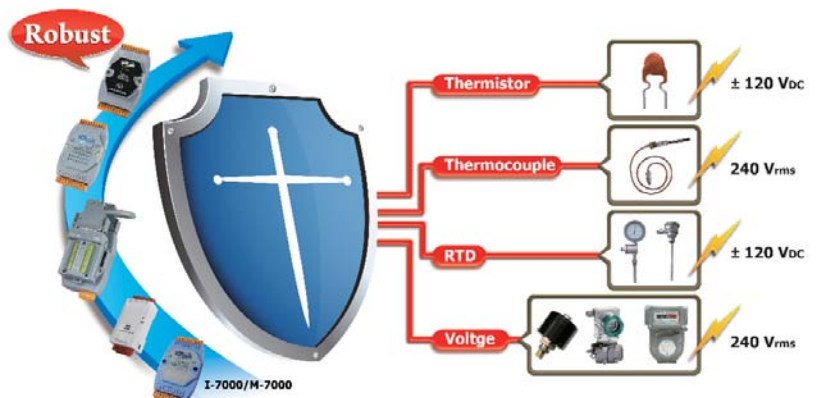

❖ Open Wire Detection

Thermocouples, RTDs, and thermistors are essential for temperature control - yet an undetected open wire can lead to catastrophic consequences including boiler overheating, equipment failure, fires, or explosions. Our modules feature built-in open-wire detection that identifies faults, preventing potential disasters while ensuring personnel safety and asset protection.

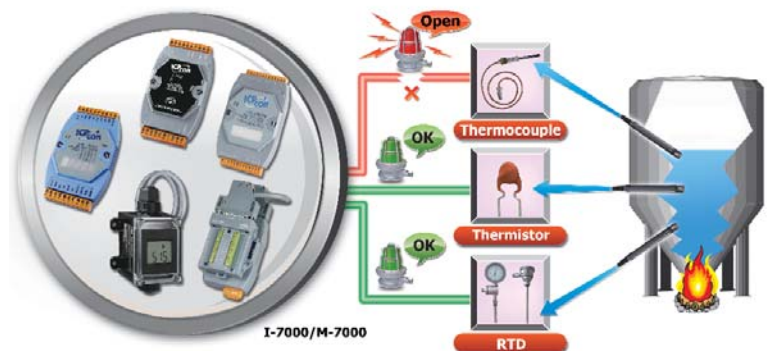

❖ Over-current Protection

Our modules feature robust overvoltage (± 120 VDC) and overcurrent (± 1000 mA) protection in the current loop, preventing damage from power surges or wiring faults. This ensures reliable, uninterrupted operation in harsh industrial.

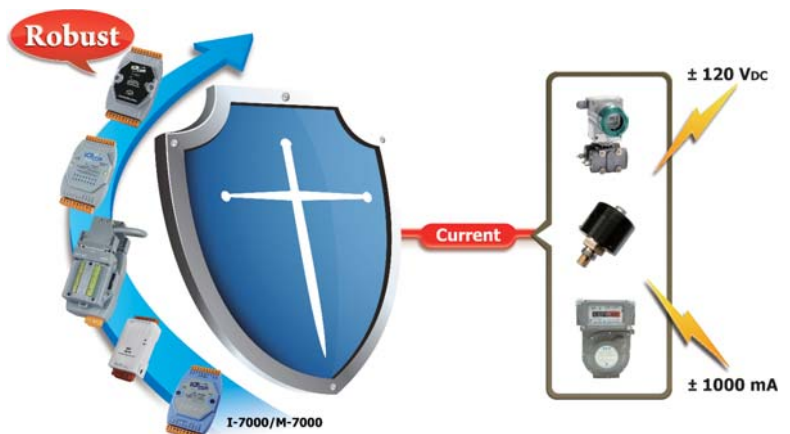

❖ Virtual Channel-to-Channel Isolation

The "R" and "Z" version of analog input modules provide ± 400 VDC virtual channel-to-channel isolation to avoid the noise interference from adjacent channel in the industrial environment. To name a few of the modules, they are I-7017R, I-7017Z, I-7018R, I-7018Z, I-7019R, and I-7019Z.

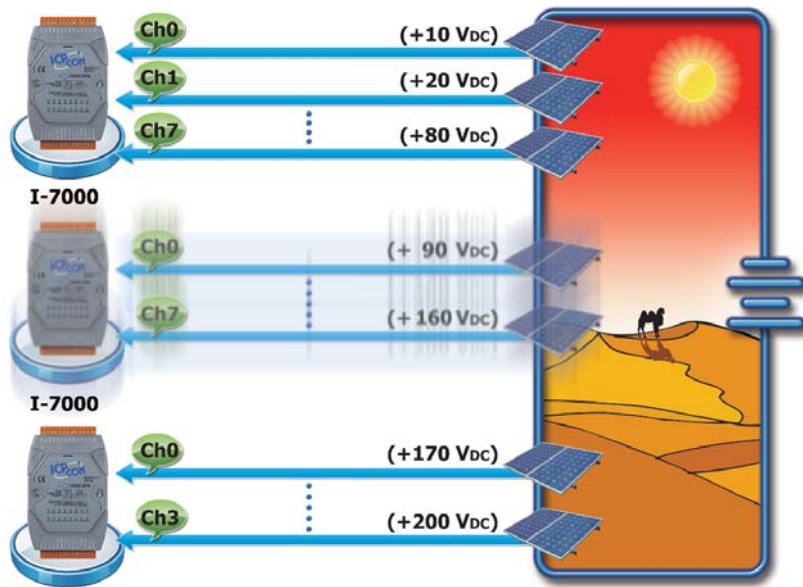
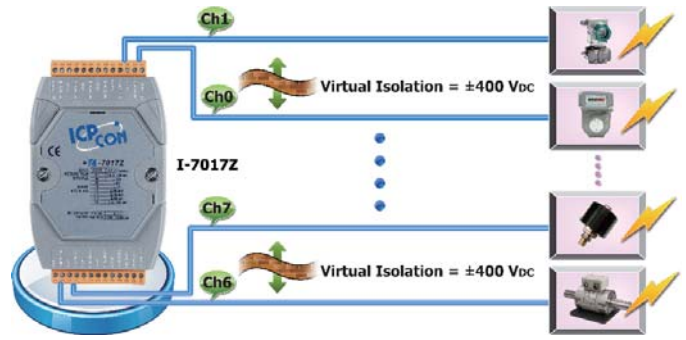

❖ Common Voltage Protection

The typical application is to monitor the charging status of the batteries in series. The voltage of each battery is +10 VDC so the first battery is +10 VDC, the second battery is +20 VDC etc. The differential voltage of the 20th battery is only +10 VDC between $vin+$ and $vin-$ terminal, while the common voltage is up to 200 VDC. The inability to handle high common voltages will result in incorrect voltage readings. ICP DAS analog input modules are designed to support common voltages up to ± 200 VDC, making them ideal for industrial applications.

❖ ESD Protection

All I-7000 and M-7000 modules pass ± 4 KV ESD contact and ± 8 KV ESD air tests by static electricity gun in our laboratory. Our modules are immunity to the electrostatic discharges by using components that can clamp and resist to the high voltages defined by IEC 61000-4-2 standard.

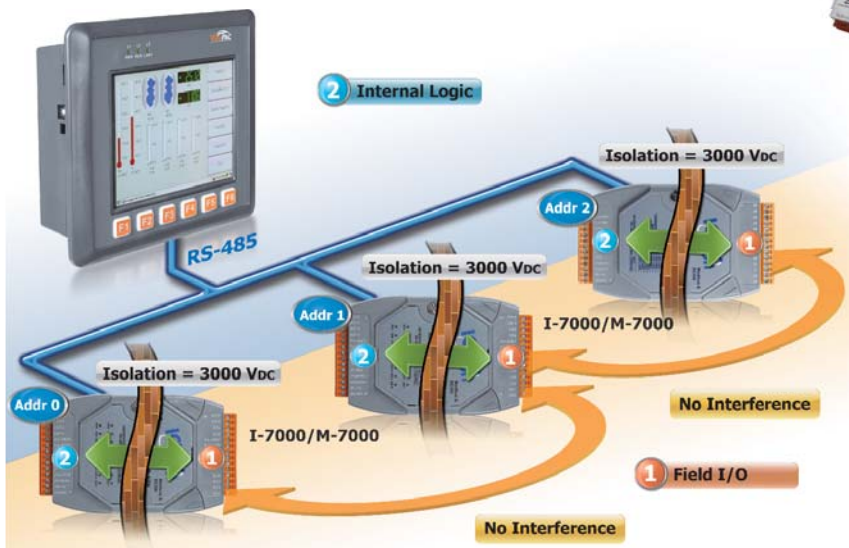

❖ 3000 VDC Isolation

The I-7000 and M-7000 modules feature 3000 VDC isolation between field I/O and internal logic circuits. This high-grade isolation effectively blocks noise and prevents damaging transients from reaching sensitive internal components, ensuring reliable operation.

❖ RS-485 Industrial Multi-Drop Network

I-7000/M-7000 series modules use the industrial EIA RS-485 communication interface to transmit and receive data at high speed over long distances up to 1.2 km (4000 ft).

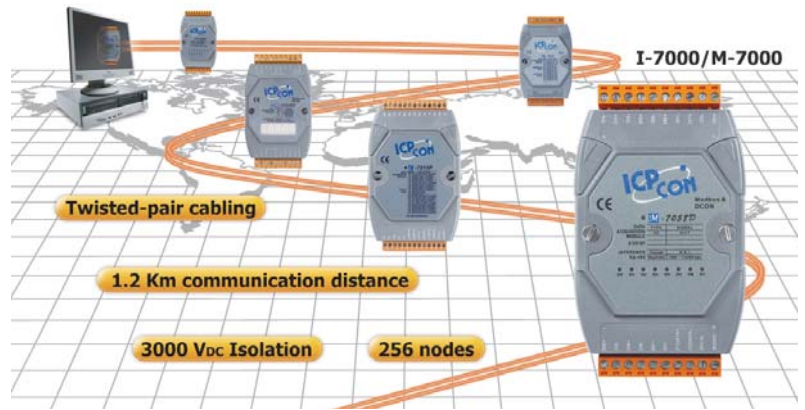

❖ Dual Communication Protocols

All I-7000 and M-7000 modules communicate using the simple DCON command/response protocol. Additionally, the M-7000 series supports Modbus RTU, an industry-standard protocol. Users can develop applications in high-level programming languages like C, VB, or Delphi, while popular software packages-including LabVIEW, InduSoft, TRACE MODE, EZ Data Logger, and EZ Prog-offer direct control of these modules.

❖ Self-Tuner Inside



The patented Self-Tuner ASIC automatically adjusts baud rates, data formats, and efficiently manages RS-485 communication line direction. These features enable seamless and flexible remote I/O configurations over RS-485 networks with ease.

❖ Scalable and Reliable Networking

The I-7510AR is a high-speed, three-way isolation repeater designed to extend serial communication networks by an additional 1.2 km (4,000 ft). It provides robust electrical isolation between the two RS-422/485 ports and the power input circuits, protecting connected devices. Additionally, it offers effective noise suppression and signal waveform enhancement on its RS-422/485 ports, ensuring reliable and high-quality data transmission. The I-7510AR also enables seamless conversion between four-wire RS-422 and two-wire RS-485 signals, providing exceptional flexibility in network configuration.

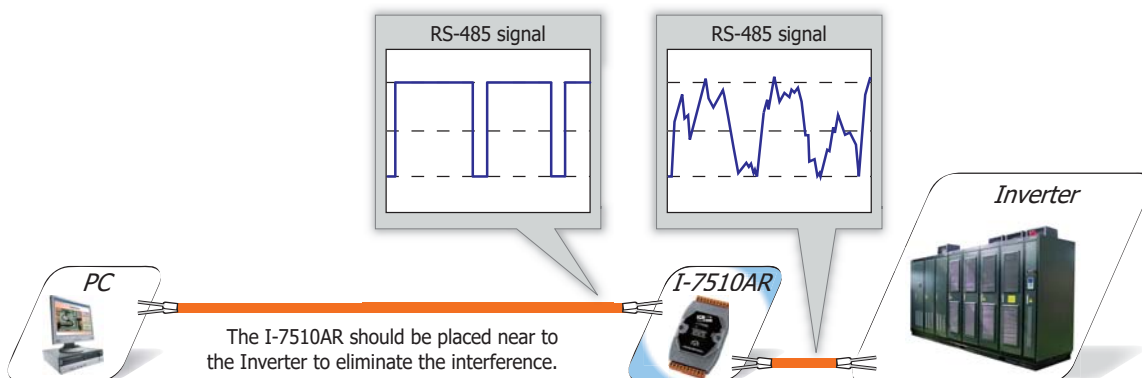

❖ Easy and Stable Installation



I-7000/M-7000
DIN-Rail Mounting



I-7000/M-7000
Stack Mounting

Software Support:

1. DCON Utility

DCON Utility is an easy-to-use utility for searching, configuring, and testing the I-7000 and M-7000 modules via the serial port (RS-232/485).

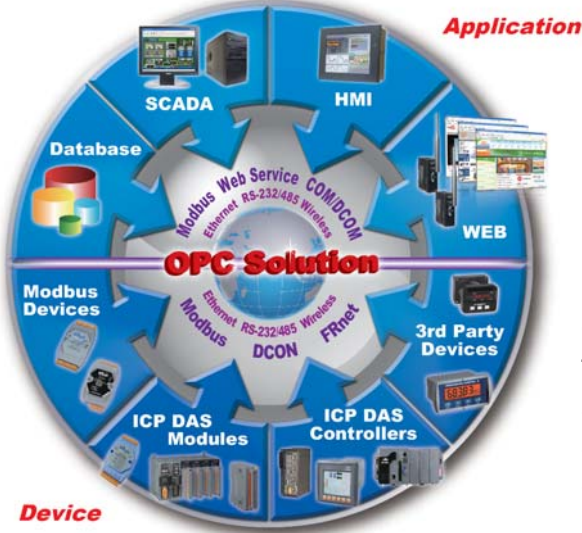
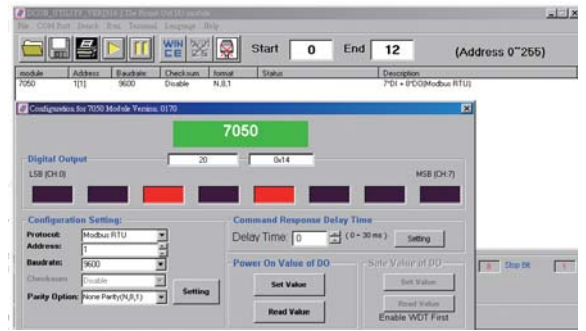

2. OPC Data Access (DA) Server

Supporting the OPC protocol, the NAPOPC_ST DA Server enables seamless communication between ICP DAS products and various SCADA, HMI, and database systems. It is available in free and licensed versions, with the licensed option allowing third-party device integration.

This server streamlines integration between diverse software and hardware components, enhancing system interoperability and ensuring efficient data exchange. Designed for industrial and manufacturing environments, it ensures reliable data flow, simplifies configuration and maintenance, and optimizes system efficiency and productivity.

3. EZ Data Logger for Windows

EZ Data Logger is an efficient and compact data logging solution that supports Modbus TCP/RTU/ASCII and DCON protocols, providing access to a wide range of slave I/O devices. It is ideal for small-scale data logging and remote I/O control applications. With its user-friendly interface, users can easily set up a small SCADA system without any programming skills.

4. eLogger – User-Friendly HMI and Data Logging

eLogger is an easy-to-use HMI, Web HMI, and data logging software for Windows 10/11 PCs and ICPDAS PACs, enabling simple I/O monitoring and system control. It supports Modbus TCP/RTU protocols, allowing seamless integration with various slave I/O devices. eLogger is free for up to 30 tags on the PC version, helping to reduce costs and time to market.

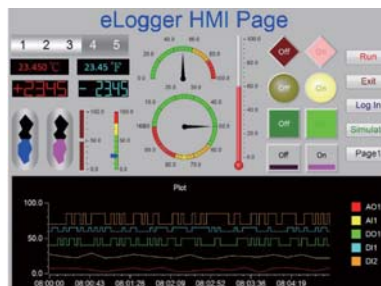

5. Various Software Development Toolkits

Plenty of library functions and demo programs are provided to let user develop programs easily under Windows, Linux and DOS operating systems. We also provide LabVIEW driver and InduSoft driver for all I-7000 and M-7000 modules. The SDK includes: DLL, LabVIEW driver, InduSoft driver, Linux driver.

Selection Guide:

 Voltage & Current Input



Model Name		Analog Input							Note
		Channels	Resolution	Sampling Rate (total)	Range	Common Voltage Protection	Individual Channel Configurable	Overtoltage Protection	
I-7012 I-7012D	-	1 diff.	16-bit	10 Hz	±150 mV, ±500 mV, ±1 V, ±5 V, ±10 V, ±20 mA (Note1)	±100 VDC		±120 VDC	DI × 1 (Note3)
I-7012F I-7012FD	-			10/100 Hz	DO × 2 (Note4)				
I-7017	M-7017	8 diff.	16-bit	10 Hz	±150 mV, ±500 mV, ±1 V, ±5 V, ±10 V, ±20 mA (Note1)	±15 VDC	-	±120 VDC	-
I-7017C	M-7017C				0 ~ 20 mA, 4 ~ 20 mA, ±20 mA (Note2)			-	
I-7017F	-			10/60 Hz	±150 mV, ±500 mV, ±1V, ±5 V, ±10 V, ±20 mA (Note1)	±200 VDC	-	±120 VDC	
I-7017FC	-				0 ~ 20 mA, 4 ~ 20 mA, ±20 mA (Note2)			-	
I-7017R	M-7017R				±150 mV, ±500 mV, ±1 V, ±5 V, ±10 V, ±20 mA (Note1)			Yes (Note6)	
I-7017R-A5	M-7017R-A5			10/50 Hz	±50 V, ±150 V,	-	-	200 VDC	
I-7017RC	M-7017RC			10/60 Hz	0 ~ 20 mA, 4 ~ 20 mA, ±20 mA (Note2)			-	
-	M-7017RMS			10 Hz	0 ~ +10 Vrms, 0 ~ +5 Vrms, 0 ~ 1 Vrms, 0 ~ 500 mVrms, 0 ~ 150 mVrms	-	-	±35 VDC	
I-7017Z	M-7017Z			10 diff. or 20 SE	16-bit	10/60 Hz	±150 mV, ±500 mV, ±1 V, ±5 V, ±10 V, 0 ~ 20 mA, 4 ~ 20 mA, ±20 mA (Note5)	±200 VDC	
-	M-7017mc-16	16 diff/SE	10/200 Hz	0 ~ 20 mA, 4 ~ 20 mA, ±20 mA			25 VDC		±110 VDC

Note1: Need external 125 Ω resistors.

Note2: Doesn't need external 125 Ω resistors.

Note3: Can be used as DI and low speed (50 Hz) counter.

Note4: Can be used as DO or High/Low Alarm.

Note5: Jumper selectable.

Note6: Only available with the firmware version of 7017R series is B3.9 and later.

 Thermocouple Input



Model Name		Analog Input							Note	
		Channels	Resolution	Sampling Rate (total)	Range	Sensor Type	Open Wire Detection	Individual Channel Configurable		Overvoltage Protection
I-7011 I-7011D	-	1 diff.	16-bit	10 Hz	±15 mV, ±50 mV, ±100 mV, ±500 mV, ±1 V, ±2.5 V,	Thermocouple J.K.T.E.R. S.B.N.C	Yes		±5 VDC	DI × 1 (Note2) DO × 2 (Note3)
I-7011P I-7011PD	-				±20 mA (Note1)	Thermocouple J.K.T.E.R. S.B.N.C.L.M				
-	M-7018-16	16 diff.			±15 mV, ±50 mV, ±100 mV, ±500 mV, ±1 V, ±2.5 V, 0 ~ 20 mA, 4 ~ 20 mA ±20 mA (Note1)	Thermocouple J.K.T.E.R. S.B.N.C			±30 VDC	
I-7018	M-7018	8 diff.	16-bit	10 Hz	±15 mV, ±50 mV, ±100 mV, ±500 mV, ±1 V, ±2.5 V, 0 ~ 20 mA, 4 ~ 20 mA ±20 mA (Note1)	Thermocouple J.K.T.E.R. S.B.N.C	-		±120 VDC	-
I-7018P	-					Thermocouple J.K.T.E.R. S.B.N.C.L.M			±80 VDC	
I-7018R	M-7018R					Thermocouple J.K.T.E.R. S.B.N.C				
I-7019R	M-7019R	8 diff.			±15 mV, ±50 mV, ±100 mV, ±150 mV, ±500 mV, ±1 V, ±2.5 V, ±5 V, ±10 V, ±20 mA (Note4)	Thermocouple J.K.T.E.R.S. B.N.C.L.M, LDIN43710		Yes	±240 Vrms	

- Note1: Need external 125 Ω resistors.
- Note2: Can be used as DI and low speed (50 Hz) counter.
- Note3: Can be used as DO or Alarm.
- Note4: Jumper selectable.

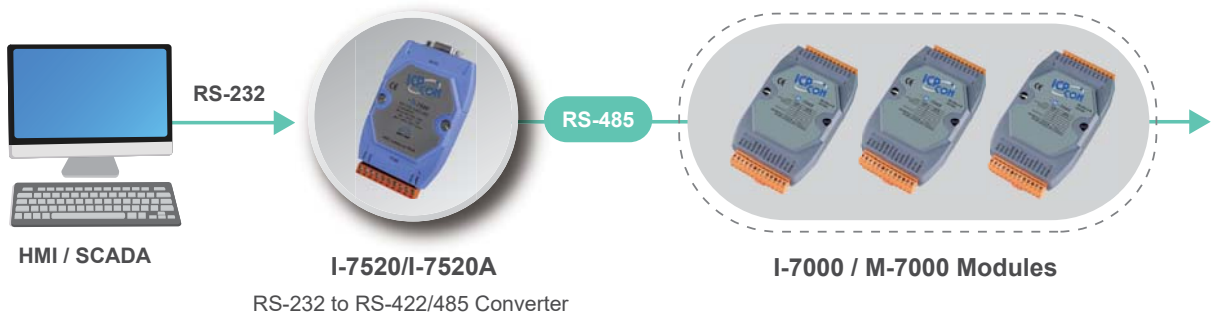

✓ Thermocouple Input



Model Name		Analog Input								Note
		Channels	Resolution	Sampling Rate (total)	Range	Sensor Type	Open Wire Detection	Individual Channel Configurable	Overvoltage Protection	
I-7018Z	M-7018Z	10 diff.	16-bit	10 Hz	±15 mV, ±50 mV, ±100 mV, ±500 mV, ±1 V, ±2.5 V, 0 ~ 20 mA, 4 ~ 20 mA ±20 mA (Note1)	Thermocouple J.K.T.E.R.S. B.N.C.L.M, LDIN43710	Yes	Yes	±240 Vrms	-
-	M-7019Z				±15 mV, ±50 mV, ±100 mV, ±150 mV, ±500 mV, ±1 V, ±2.5 V, ±5 V, ±10 V, 0 ~ 20 mA, 4 ~ 20 mA ±20 mA (Note2)					

Note1: Need external 125 Ω resistors.
Note2: Jumper selectable.

<p>I-7018Z-G/S = I-7018Z + DB-1820 M-7018Z-G/S = M-7018Z + DB-1820 M-7019Z-G/S = M-7019Z + DB-1820</p>	<p>I-7018Z-G/S2 = I-7018Z + DN-1822 M-7018Z-G/S2 = M-7018Z + DN-1822 M-7019Z-G/S2 = M-7019Z + DN-1822</p>	<p>I-7018Z-G/S3 = I-7018Z + DN-1823 M-7018Z-G/S3 = M-7018Z + DN-1823 M-7019Z-G/S3 = M-7019Z + DN-1823</p>
---	--	--

✓ RTD Input





Model Name		Analog Input							
		Channels	Resolution	Sampling Rate (total)	Sensor Type	Open Wire Detection	Individual Channel Configurable	3 Wire RTD long distance measurement	Overvoltage Protection
I-7013	-	1	16-bit	10 Hz	Pt100, Pt1000, Ni120	-	-	Yes	±5 V
-	M-7013P M-7013PD	1 (Note1)							±30 V
I-7015	M-7015	6 diff.	12 Hz	Pt100, Pt1000, Ni120, Cu50, Cu100, CU1000	Yes	Yes	-	±110 V	
I-7015P	M-7015P								
I-7033	M-7033	3 diff.	15 Hz	Pt100, Pt1000, Ni120	-	-	Yes	±5 V	
I-7033D	M-7033D								

Note1: M-7013P also includes 1 × DI (Dry contact, Source), 2 × DO (Open Collector, MOSFET, Sink, 700mA)

 **DS18B20 Sensor** 

Model Name		Analog Input							
		Ports	Resolution	Sampling Rate	Sensor Type	Temperature Measurement Range	Open Wire Detection	Sensor Wiring Cables Length	Sensors per Ports
-	M-7004	4	12-bit	1 Hz	DS18B20	-55°C ~ +125°C	-	100m per port	20

 **Optional Accessories**



 <p>CA-TP1-M100-L020 3-wire DS18B20, Stainless steel, 2M (-30 °C ~ 125 °C)</p>	 <p>CA-TP1-M200-L020 3-wire DS18B20, copper nickel plated, 2 M (-30 °C ~ 125 °C)</p>
--	---

 **Thermistor Input** 

Model Name		Analog Input							Digital I/O
		Channels	Resolution	Sampling Rate	Sensor Type	Open Wire Detection	Individual Channel Configurable	Overvoltage Protection	
I-7005	M-7005	8 diff.	16-bit	8 Hz	Precon ST-A3, Fenwell U, YSI L100, YSI L300, YSI L1000, YSI B2252, YSI B3000, YSI B5000, YSI B6000, YSI B10000, YSI H10000, YSI H30000, User-defined	Yes	Yes	±120 VDC	DO × 6 (Note1)

Note1: Can be used as DO or High/Low Alarm.

 **Optional Accessories**

 <p>CA-TM-P100-L020 NTC Thermistor, Epoxy Resin Cable, 2 M (-40 °C ~ +80 °C)</p>	 <p>CA-TM-P100-L050 NTC Thermistor, Epoxy Resin Cable, 5 M (-40 °C ~ +80 °C)</p>
--	--

 **Transmitter Input** 

Model Name		Analog Input								Digital I/O
		Channels	Resolution	Sampling Rate	Range	Input Linear Scaling	Open Wire Detection	Individual Channel Configurable	Overvoltage Protection	
I-7014D	-	1 diff.	16-bit	10 Hz	±150 mV, ±500 mV, ±1 V, ±5 V, ±10 V, ±20 mA (Note1)	Yes	-	-	±15 VDC	DI × 1 (Note2) DO × 2 (Note3)

Note1: Need external 125 Ω resistors.
Note2: Can be used as DI and low speed (100 Hz) counter.
Note3: Can be used as DO or High/Low Alarm.

✓ Strain Gauge



Model Name		Strain Gauge Input						Digital I/O
		Channels	Resolution	Sampling Rate	Sensor Type	Input Linear Scaling	Overvoltage Protection	
I-7016 I-7016D	M-7016 M-7016D	2 diff.	16-bit	10 Hz / 1 channel, 2 Hz / 2 channels	4-Wire Strain Gauge	Yes	±5 V	DI × 1 (Note1) DO × 4 (Note2)
I-7016P I-7016PD	-	1 diff.		10 Hz	6-Wire Strain Gauge			

Note1: Can be used as DI and low speed (50 Hz) counter.
Note2: Can be used as DO or Alarm.

✓ Analog Output



Model Name		Analog Output					
		Channels	Resolution	Voltage Output	Current Output	Safe Value	Power-on Value
I-7021	-	1	12-bit	0 ~ 10 V	0 ~ +20 mA, +4 ~ +20 mA	Yes	Yes
I-7021P	-		16-bit				
I-7022	M-7022	2 (Note1)	12-bit	0 ~ +5 V, 0 ~ +10 V			
I-7024	M-7024	4	14-bit	±10 V, 0 ~ 10 V, ±5 V, 0 ~ 5 V			
I-7024R	M-7024R	4 (Note2)					
-	M-7024U M-7024UD (Note3)	4 (Note4)	16-bit				
-	M-7024L	4	12-bit				
-	M-7028 M-7028D	8					

Note1: Channel-to-channel isolation.
Note2: M-7024R also includes 5 channel DI (Dry Contact).
Note3: M-7024UD includes LED for DI and DO status.
Note4: M-7024U and M-7024UD also include 4 × DI(Dry and Wet contact)

✓ Multi-function



Model Name	Analog Input		Analog Output		Digital Input		Digital Output	
	Channels	Range	Channels	Range	Channels	ON Voltage Level	Type	Load Current
M-7002	4	±150 mV, ±500 mV, ±1 V, ±5 V, ±10 V, 0 ~ 20 mA, 4 ~ 20 mA, ±20 mA (Note1)	-	-	5	10 ~ 50 VDC	Power Relay (Form A)	5 A @ 250 VAC/ 30 VDC
M-7003	8		-	-				
M-7026	6		±10 V, 0 ~ 10 V, ±5 V, 0 ~ 5 V, 0 ~ 20 mA, 4 ~ 20 mA (Note1)	2	±10 V, 0 ~ 10 V, ±5 V, 0 ~ 5 V, 0 ~ 20 mA, 4 ~ 20 mA (Note1)	3	Close to GND	Open Collector × 3

Note1: Jumper selectable.

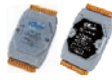
 DC Digital Input

Model Name		Digital Input						
		Channels (Note1)	Type	ON Voltage Level		OFF Voltage Level	Field-to-Logic Isolation	
I-7041 I-7041D	M-7041 M-7041D	14 (Sink/Source)	Common Source	+1 VDC Max.	+4 ~ +30 VDC	+4 ~ +30 VDC	+1 VDC Max.	3750 VDC
I-7041P I-7041PD	M-7041P M-7041PD			+11 VDC Max.	+19 ~ +30 VDC	+19 ~ +30 VDC	+11 VDC Max.	
-	M-7041-A5 M-7041D-A5			+68 ~ +150 VDC		+48 VDC Max.		
	M-7046 M-7046D	15 (Sink/Source)	Wet Contact	+3.5 ~ +50 VDC		+1 VDC Max.	5000 VDC	
I-7051 I-7051D	M-7051 M-7051D	16 (Sink/Source)	Common Source or Common Ground	+10 ~ +50 V		+4 V Max.	3750 VDC	
I-7052 I-7052D	M-7052 M-7052D	8 (Sink/Source)	6 Differential and 2 Common Ground (Note2)	+4 ~ +30 V		+1 V Max.	5000 Vrms	
I-7053_FG I-7053D_FG	M-7053 M-7053D	16 (Source)	Dry Contact	Open		Close to GND	-	

Note1: DI channel can be used as DI and low speed (100Hz) counter.

Note2: 6 differential inputs provide 2 KV channel to channel isolation.

 DC Digital Output

Model Name		Digital Output					
		Channels	Type	Load Voltage	Load Current	Short-circuit Protection	Field-to-Logic Isolation
I-7042 I-7042D	-	13 (Sink)	Open Collector (NPN)	+3.5 ~ +30 V	100 mA/Channel	-	3750 Vrms
I-7043 I-7043D	-	16 (Sink)		+10 ~ +30 V			-
I-7045 I-7045D	M-7045 M-7045D	16 (Source)	Open Source (N-MOSFET)	+10 ~ +40 V	650 mA/Channel	Yes	3750 Vrms
I-7045-NPN I-7045D-NPN	M-7045-NPN M-7045D-NPN	16 (Sink)	Open Collector (NPN)	+3.5 ~ +50 V	700 mA/Channel		3750 VDC

 DC Digital Input/Output

Model Name		Digital Input			Digital Output			
		Channels (Note1)	ON Voltage Level	OFF Voltage Level	Channels	Load Voltage	Load Current	Short-circuit Protection
I-7044 I-7044D	-	4 (Sink/Source, 3750 Vrms)	+1 VDC Max.	+4 ~ +30 VDC	8 Open Collector (Sink, 3750 Vrms)	+3.5 ~ +30 V	375 mA	-
I-7050 I-7050D	M-7050 M-7050D	7 (Source, Non-Isolation)	Open	Close to GND	8 Open Collector (Sink, Non-Isolation)		30 mA	
I-7050A I-7050AD	-	7 (Sink, Non-Isolation)	+4 ~ +30 VDC	+1 VDC Max.	8 Open Collector (Source, Non-Isolation)		50 mA	
I-7055 I-7055D	M-7055 M-7055D	8 (Sink/Source, 3750 VDC)	Dry: Close to GND Wet: +10 ~ +50 V	Dry: Open Wet: +4 V Max.	8 Open Source (Source, 3750 VDC)	+10 ~ +40 V	650 mA	Yes
I-7055-NPN I-7055D-NPN	M-7055-NPN M-7055D-NPN	8 (Sink/Source, 3750 VDC)			8 Open Collector (Sink, 3750 VDC)	+3.5 ~ +50 V	700 mA	
-	M-7055U M-7055UD	8 (Sink/Source, 2000 VDC)			8 Push-Pull (Sink/Source, 2000 VDC)	+3.5 ~ +80 V	500 mA	

Note1: DI channel can be used as DI and low speed (100 Hz) counter.

✓ DC Universal Digital Input/Output



Model Name		DI + DO	Digital Input		Digital Output			
		Channel	Type	Sink/Source	Type	Load Voltage	Load Current	Short-circuit Protection
-	M-7054 M-7054D	16	Dry Contact	Source	Open Collector (Sink)	+ 5 ~ + 30 VDC	100 mA/channel	-
-	M-7054P M-7054PD					+ 5 ~ + 50 VDC	500 mA/channel	Yes

Note1: DI channel can be used as DI and low speed (100 Hz) counter.

✓ AC/DC Digital Input



Model Name		Digital Input				Digital Output			
		Channels (Note1)	Type	Sink/Source	ON Voltage Level	Channels	Type	Sink/Source	Load Current
I-7058 I-7058D	M-7058 M-7058D	8	Wet Contact	Sink/Source	80 ~ 250 VAC ±80 ~ ±250 VDC	-	-	-	-
I-7059 I-7059D	M-7059 M-7059D				10 ~ 80 VAC ±15 ~ ±80 VDC				
-	M-7058-16 M-7058D-16	16	Wet Contact	Sink/Source	80 ~ 250 VAC ±100 ~ ±250 VDC	2	Isolated Open Collector	Sink	600 mA/Channel
-	M-7059-16 M-7059D-16				10 ~ 80 VAC ±15 ~ ±80 VDC				

Note1: DI channel can be used as DI and low speed (100 Hz) counter.



M-7058(D)/M-7059(D)
123 mm x 72 mm x 35 mm (W x L x H)



M-7058(D)-16/M-7059(D)-16
121 mm x 76 mm x 42 mm (W x L x H)

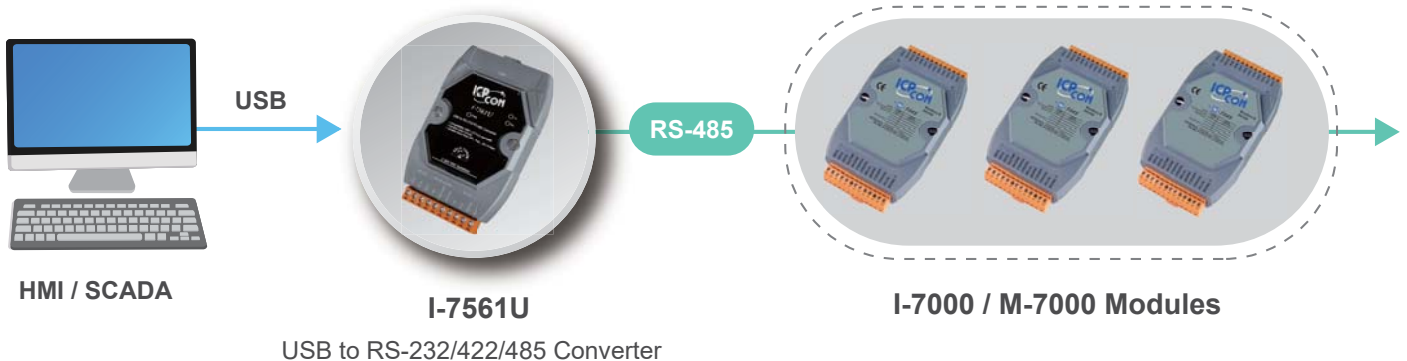

 DC Digital Input/Power Relay Output



Model Name		Digital Input		Power Relay Output				
		Channels	ON Voltage Level	Channels	Contact Rating	Operate Time	Release Time	Electrical Endurance
I-7060 I-7060D	M-7060 M-7060D	4 (3750 Vrms)	+1 VDC Max.	RL1, RL2: Form A × 2 RL3, RL4: Form C × 2	0.6 A @ 125 VAC 2 A @ 30 VDC	3 ms	2 ms	5 × 10 ⁵ ops.
-	M-7060P M-7060PD		+4 VDC Max.		Form A: 16 A @ 250 VAC 10 A @ 30 VDC Form C: NO: 10 A @ 250 VAC NC: 6 A @ 250 VAC	10 ms	5 ms	1 × 10 ⁷ ops.
I-7061 I-7061D	M-7061 M-7061D	-	-	Form A × 12	5 A @ 250 VAC 5 A @ 30 VDC	10 ms	5 ms	1 × 10 ⁵ ops.
I-7063 I-7063D	-	8 (3750 Vrms)	+1 VDC Max.	Form A × 3		6 ms	3 ms	
I-7065 I-7065D	M-7065 M-7065D	4 (3750 Vrms)		Form A × 5				
I-7067 I-7067D	M-7067 M-7067D	-	-	Form A × 7	0.5 A @ 120 VAC 1.0 A @ 24 VDC	5 ms	2 ms	2 × 10 ⁵ ops.
-	M-7068 M-7068D			2 A @ 30 VDC 0.24 A @ 220 VDC 0.25 A @ 250 VAC	3 ms	4 ms		
-	M-7069 M-7069D	-	-	Form A × 4 Form C × 4	Form A: 6 A @ 35 VDC 6 A @ 240 VAC Form C: 5 A @ 30 VDC 5 A @ 250 VAC	5 ms	1 ms	1 × 10 ⁵ ops.

 DC Digital Input/Solid-State Relay Output



Model Name		Digital Input		Solid-State Relay Output		
		Digital Input Channels	ON Voltage Level	Channels	Contact Rating	Operate Time
I-7063A I-7063AD	-	8 Isolation with common Source (3750 Vrms)	+1 VDC Max.	3 AC-SSR	24 ~ 265 VAC @ 1A	1/2 cycle +1 mS
I-7063B I-7063BD	-			3 DC-SSR	3 ~ 30 VDC @ 1A	1 mS
I-7065A I-7065AD	-	4 Isolation with common Source (3750 Vrms)		5 AC-SSR	24 ~ 265 VAC @ 1A	1/2 cycle +1 mS
I-7065B I-7065BD	M-7065B M-7065BD			3 DC-SSR	3 ~ 30 VDC @ 1A	1 mS

 PhotoMOS Relay Output



Model Name		PhotoMOS Relay Output					
		Channels	Contact Rating		Field-to-Logic Isolation	Operate Time	Release Time
I-7066 I-7066D	-	Form A × 7	350 V @ 0.13 A	AC peck or DC: 0.24 A @ 220 VDC 0.25 A @ 250 VAC	5000 VDC	2 ms Max.	1 ms Max.
-	M-7066P M-7066PD		80 V @ 1 A		2000 VDC	5 ms Max.	0.2 ms Max.

✓ Counter/Frequency



Model Name		Counter/Frequency							
		Channel	Counter Mode	Encoder Mode	Counter/Encoder Bits	ON Voltage Level	Max. Speed	Frequency Accuracy	Virtual Battery Backup
I-7080 I-7080D	M-7080 M-7080D	2	Up	-	32-bit	Isolated: +3.5 ~ +30 VDC	100 kHz	1 Hz or 10 Hz	-
I-7080B I-7080BD	M-7080B M-7080BD					Non-isolated: +2.4 ~ +5 VDC			Yes
-	M-7084	4/8	Up or Up/Down	CW/CCW, Dir/Pulse, AB Phase		+3.5 ~ +30 VDC	+3.5 ~ +10 VDC : 200 kHz +10 ~ +30 VDC : 150 kHz	1 Hz ~ 200 kHz (±0.025% of Input Frequency)	Yes

✓ Encoder/Counter





Model Name		Encoder/Counter						
		Channels	Type	Encoder Mode	Bits	ON Voltage Level	Max. Speed	Virtual Battery Backup
I-7083 I-7083D	-	3-axis	Encoder	CW/CCW, Pulse/Dir, AB Phase	32-bit	5 V: +3.5 ~ +5 VDC 12 V with 1 kΩ External	1 MHz	-
I-7083B I-7083BD	-					Resistor: +5 ~ +12 VDC 24 V with 2 kΩ External Resistor: +7 ~ +24 VDC		Yes

✓ PWM Output/Counter Input



Model Name		Counter Input						PWM Output				
		Channels	Type	Counter Mode	Bits	ON Voltage Level	Max. Speed	Virtual Battery Backup	Channels	Load Voltage	Duty Cycle	Frequency
I-7088 I-7088D	M-7088 M-7088D	8	Counter	Up	32-bit	+3.5 ~ +5 VDC	1 MHz	Yes	8	+5 VDC	0.1 ~ 99.9%	1 Hz ~ 500 KHz
I-7088/S I-7088D/S	M-7088/S M-7088D/S					+3.5 ~ +50 VDC				+5 ~ +50 VDC		
-	M-7088-16					16						

 <p>I-7088D/M-7088D 123 mm x 72 mm x 35 mm (W x L x H)</p>	 <p>I-7088-G/S = I-7088 + DN-8P8C-CA M-7088-G/S = M-7088 + DN-8P8C-CA</p>	 <p>M-7088-16 121 mm x 76 mm x 42 mm (W x L x H)</p>
--	---	--

1.2 M-2000 Slim-Type I/O Modules



The M-2000 series consists of a range of network data acquisition and control modules with both digital and analog I/O capabilities. These modules can be remotely controlled via an RS-485 serial bus using DCON and Modbus RTU protocols. The RS-485 port supports selectable transmission speeds of up to 115,200 bps. Modbus is a widely adopted industry standard for communication and is the most common protocol for connecting industrial electronic devices.

The M-2000 modules features a slim form factor, which helps save space during installation and supports easy wiring for distributed I/O applications. Additionally, the modules offer switch-selectable bias and terminal resistors to enhance communication reliability and resolve potential issues in RS-485 network communication.

Features:

- RS-485 Industrial Multi-Drop Network
- Communication Distances Up to 1.2 km (4000 ft)
- Communication Protocols: **DCON, Modbus RTU**
- Programmable I/O Type and Range
- DI Latch Function for Simplified Control Logic
- All DIs Act as 16-bit Counters (100 Hz)
- Selectable Dry/Wet Contact Inputs via Wires
- Dual Watchdog with Power-on and Safe Values
- LED Indicators for Easy Diagnostics
- Up to 4 kV Contact ESD Protection
- Up to 3750 VDC High Voltage Field-to-Logic Isolation
- Power Reverse Polarity Protection for Improved Safety
- Wide Power Input Range (+10 ~ +30 VDC)
- Wide Operating Temperature Range (-25 ~ +75 °C)
- 240 Vrms Overvoltage Protection for AI Modules
- Slim-Type Form Factor for Reduced installation Space

Applications:

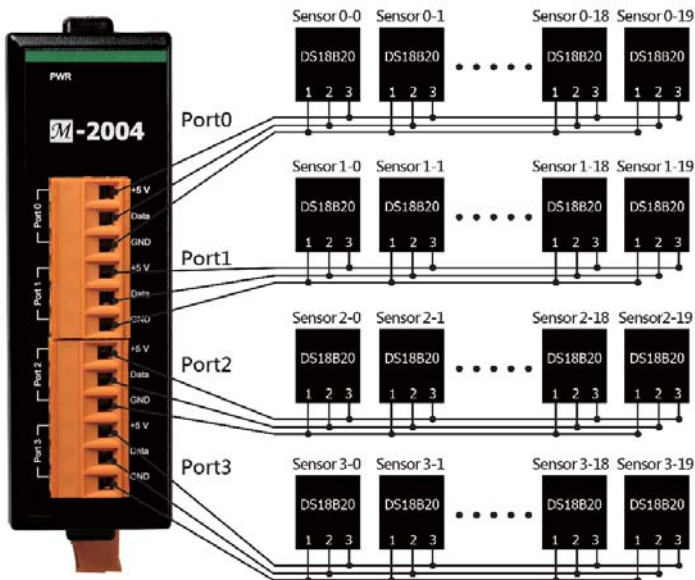

Appearance:

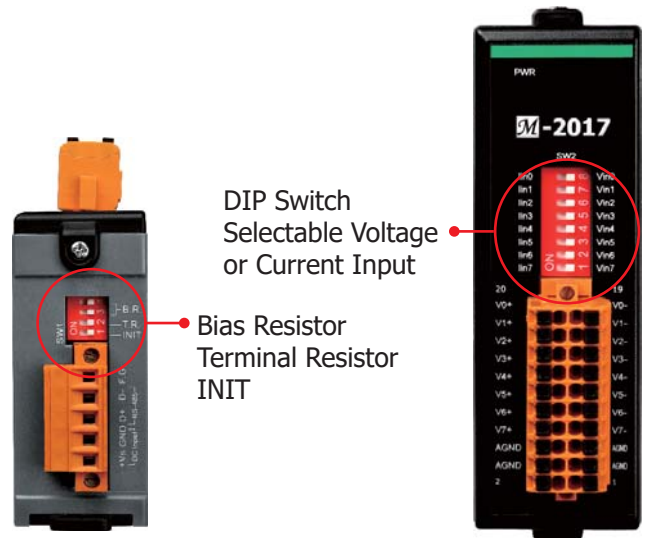

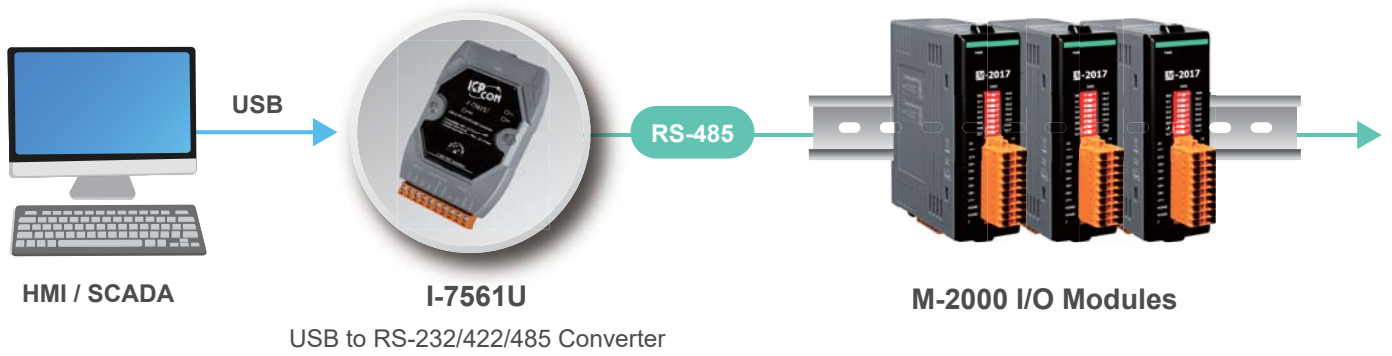

The DS18B20 digital temperature sensor offers high accuracy of $\pm 0.5^{\circ}\text{C}$ across a wide measurement range of -55°C to $+125^{\circ}\text{C}$. It outputs digital temperature data, reducing signal loss and interference compared to analog sensors. Additionally, multiple sensors can share the same data line, simplifying wiring and lowering costs.

The M-2004 module supports four input ports for 2- or 3-wire DS18B20 sensors. Each port can accommodate up to 20 DS18B20 sensors in a daisy-chain configuration, with a maximum wiring distance of 100 meters. Together, the module and sensors create a scalable and efficient temperature monitoring system.





Selection Guide:

Analog Input with Channel to Channel Isolation

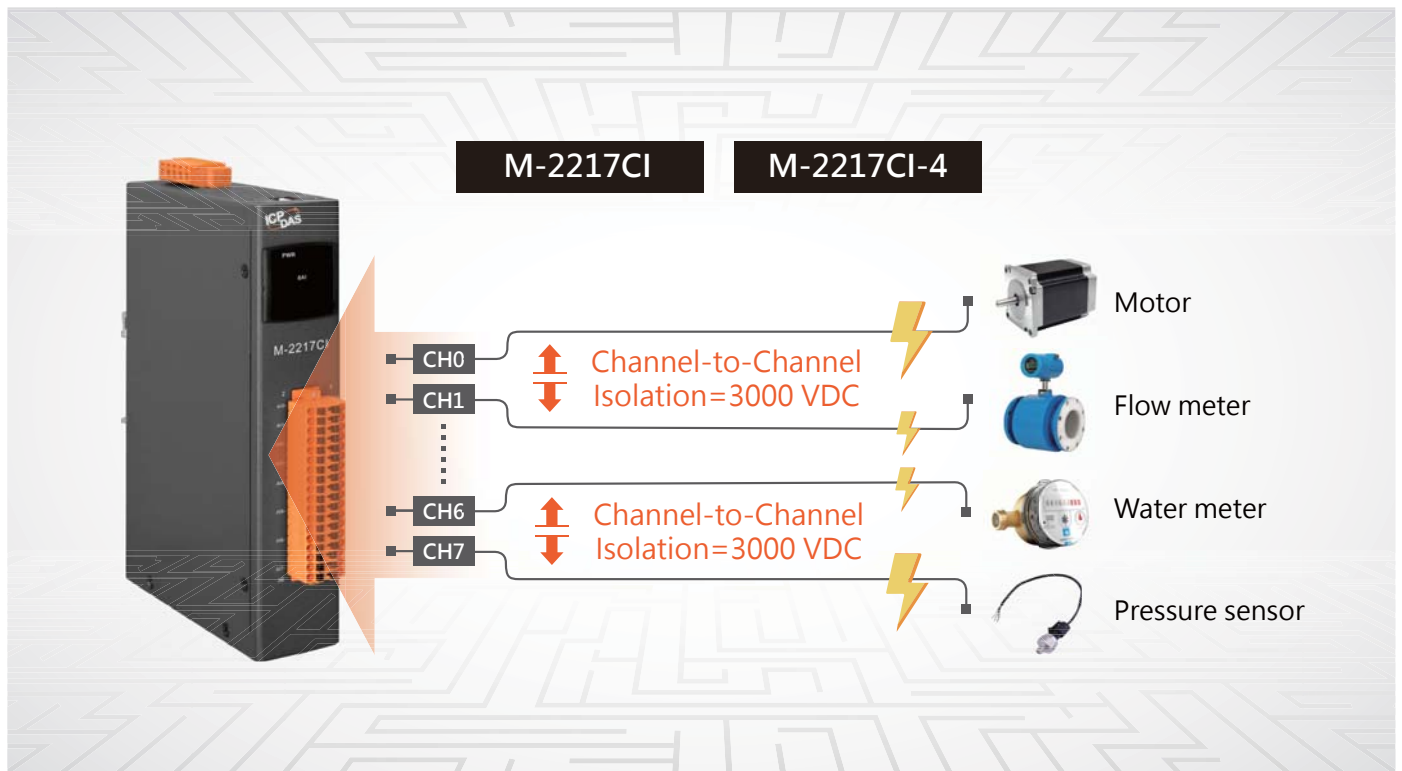

Model Name	Analog Input				
	Channel	Resolution	Voltage & Current Input	Sensor Type	Sampling Rate
 Available Soon M-2217CI-4	4	16-bit	±1 V, ±2.5 V, ±5 V, ±10 V, ±20 mA	-	Normal: 10 Hz Fast: 200 Hz
 Available Soon M-2217CI	8				



 Analog Output with Channel to Channel Isolation

Model Name	Analog Output			
	Channel	Resolution	Voltage Output	Current Output
 Available Soon M-2224CI	4	12-bit	0 ~ +5 V, 0 ~ +10 V, ±5 V, ±10 V	0 ~ +20 mA, +4 ~ +20 mA
 Available Soon M-2228CI	8			

 Analog Input

Model Name	Analog Input				
	Channel	Resolution	Voltage & Current Input	Sensor Type	Sampling Rate
 M-2004	4 <i>(Note1)</i>	12-bit	–	2/3-wire DS18B20	1 Hz
 M-2017	8	16-bit	±150 mV, ±500 mV, ±1 V, ±5 V, ±10 V, ±20 mA, 0 ~ 20 mA, 4 ~ 20 mA	–	Normal: 10 Hz Fast: 60 Hz
 M-2018-16	16		±15 mV, ±50 mV, ±100 mV, ±500 mV, ±1 V, ±2.5 V, ±20 mA, 0 ~ 20 mA, 4 ~ 20 mA <i>(requires an optional external 125 Ω resistor)</i>	Thermocouple: J, K, T, E, R, S, B, N, C	10 Hz

Note1: M-2004: each port can connect a maximum of 20 DS18B20 sensors. Total 80 sensors.

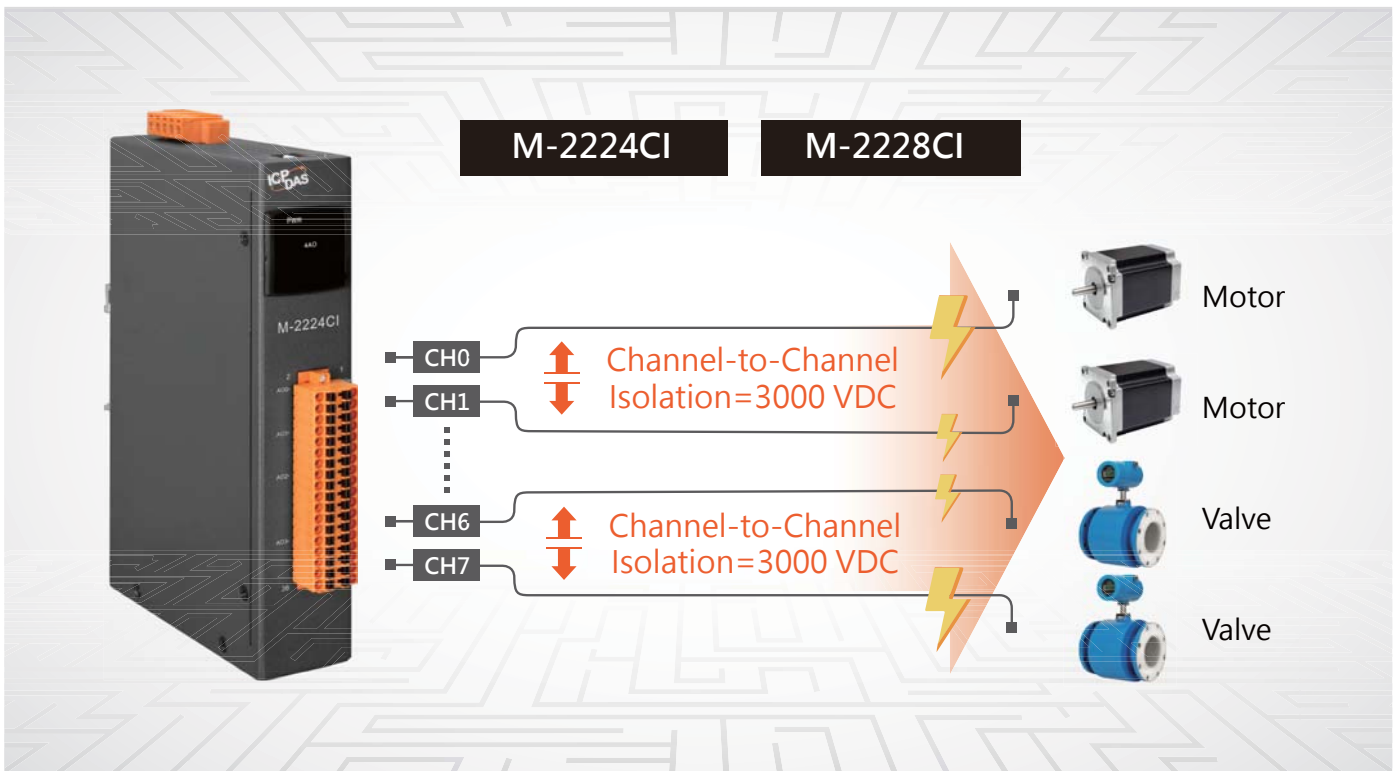

1.3 tM Tiny-Size I/O Modules



The tM series is a family of network data acquisition and control modules with digital or analog I/O functions. The modules can be remotely controlled through an RS-485 serial bus by using DCON and Modbus RTU/ASCII protocols. The selectable transmission speed of the RS-485 port is up to 115,200 bps. Modbus has become a standard communications protocol in industry, and is now the most commonly available means of connecting industrial electronic devices.

The tM series tiny RS-485 I/O modules support various I/O types, like photo-isolated digital input, power relay, photoMOS relay, open collector output, and analog input (voltage and current). Compared with the M-7000 series, the tM series is more cost-effective with low channel count design that is suitable for distributed I/O points applications.

The tM modules provide dual watchdogs to enhance reliability and stability. The module watchdog is designed to automatically reset the microprocessor when the module hangs. The host watchdog monitors the host controller (PC or PLC), and the output of the module can go to predefined safe value state when the host fails.

Features:

- RS-485 Industrial Multi-Drop Network
- Communication Distances Up to 1.2 km
- Communication Protocols:
DCON, Modbus RTU/ASCII
- Programmable I/O Type and Range
- DI Latch Function for Simplified Control Logic
- All DIs Act as 16-bit Counters (100 Hz)
- Selectable Dry/Wet Contact Inputs via Wires
- LED Indicators for Easy Diagnostics
- Up to 4 kV Contact ESD Protection
- Rugged Design with up to 3750 VDC Field-to-Logic Isolation
- Power Reverse Polarity Protection for Improved Safety
- Wide Power Input Range (+10 ~ +30 VDC)
- Wide Operating Temperature Range (-25 ~ +75 °C)
- Space-Saving Tiny Form Factor Design

Selection Guide:

Model Name	AI	AO	DI	DO
tM-AD2	2-ch Single-Ended, (Voltage/Current)	-	-	-
tM-AD5	5-ch Differential (Voltage)	-	-	-
tM-AD5C	5-ch Differential (Current)	-	-	-
tM-AD8	8-ch Single-Ended (Voltage)	-	-	-
tM-AD8C	8-ch Single-Ended (Current)	-	-	-
tM-AD4P2C2	2-ch Single-Ended (Voltage/Current)	-	2-ch (Source)	2-ch (Sink)
tM-DA1P1R1	-	1-ch (Voltage/Current)	1-ch (Sink/Source)	1-ch Form A Relay
tM-TH8	8-ch (Thermistor)	-	-	-
tM-P8	-	-	8-ch (Sink/Source)	-
tM-PDW8	-	-	8-ch (Sink/Source)	-
tM-C8	-	-	-	8-ch (Sink)
tM-P4C4	-	-	4-ch (Source)	4-ch (Sink)
tM-P4A4	-	-	4-ch (Sink)	4-ch (Source)
tM-P3R3	-	-	3-ch (Sink/Source)	3-ch Form A Relay
tM-PD3R3	-	-	3-ch (Source)	3-ch Form A Relay
tM-R5	-	-	-	5-ch Form A Relay
tM-P3POR3	-	-	3-ch (Sink/Source)	3-ch PhotoMOS Relay

1.4 RU-87Pn I/O Expansion Units

The RU-87Pn I/O Expansion Unit is designed for remote data acquisition and control through RS-485 connections. It comprises

• **CPU Module:**

Includes non-volatile memory for backing up and restoring I/O module configurations, LED indicators for diagnostics, and an RS-485 port that supports communication distances of up to 1.2 km.

• **Power Module:**

Provides stable power to the unit and its modules.

• **Backplane:**

Offers multiple I/O slots for flexible configuration with I-87KW modules, see Chapter 5.2.

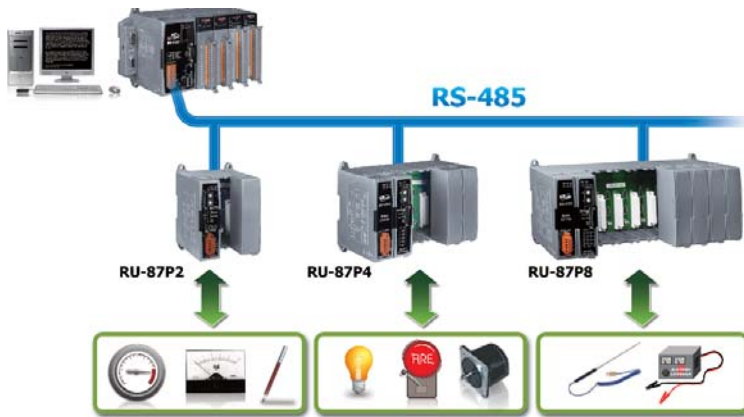

Patent



Taiwan	096134568
China	200710181138.6
USA	11/979,474

❖ **Hot Swap**

Reliable 3-piece construction enables users to hot swap modules during operation, without rewiring. All I/O module data are backed up in the non-volatile memory of the RU-87Pn. After hot-swapping a module, all settings are automatically loaded to recover.

❖ **Auto Configuration**

The I-87KW I/O modules can be pre-configured and backed up in the non-volatile memory of the RU-87Pn. When the RU-87Pn is power on or I/O modules are plugged in, the unit automatically checks and restores these configurations to each I/O module.

Rugged Industrial Environment

- Power On Value & Safe Value
- Dual Watchdog
- +10 ~ +30 VDC Power Input
- -25 ~ +75°C Operating Temperature
- ESD & Surge Protection

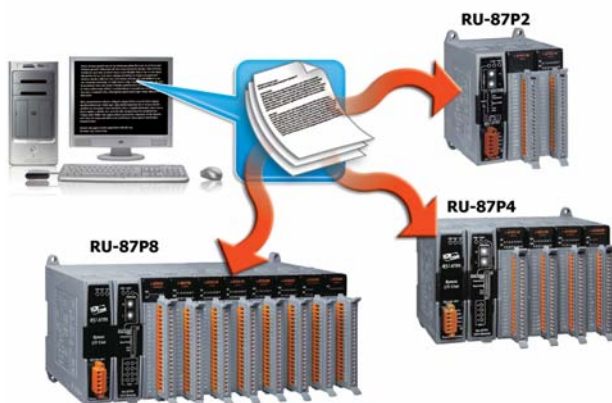

❖ **Easy Duplicate System**

Using the DCON Utility, you can easily make a backup of the I-87KW module configurations and write to another RU-87Pn. This design can easily and quickly duplicate many RU-87Pn.

❖ Easy Maintenance and Diagnosis

The basic configurations (includes station number, baudrate) are set by the rotary and DIP switches. The operator can use only one screwdriver to set the RU-87Pn. And there are several LED status indicators to show whether I-87KW modules are configured and work properly.

If one I-87KW module fails, the operator just needs to replace it with one good I-87KW module with the same item number. And then checks the LED indicators to know whether the replacement is performed correctly.

❖ Communication

• RS-485 industrial multi-drop network

The RU-87Pn uses industrial EIA RS-485 communications to transmit and receive data over long distances up to 1.2 km (4,000 ft).

• DCON protocol

The I-87KW I/O modules plugged in a RU-87Pn use the DCON protocol for communication. The protocol is designed as a simple command/response method with an easy-to-use ASCII format.

❖ Fully Software Support

The free charge software utility and development kits include

A: DCON Utility: An easy-to-use and free software tool for configuring RU-87Pn systems.

B: OPC Servers:

OPC is an industrial standard interface based on OLE technology. With the OPC server, I/O modules can be easily integrated to any software that has OPC client capability.

C. EZ Data Logger

EZ Data Logger is ideal for small remote I/O systems. Its user-friendly interface allows users to quickly and easily create data logging applications without programming skills.

D. Various Software Development Toolkits

DLL, ActiveX, LabVIEW driver, InduSoft driver, DASyLab driver, Linux driver

Appearance:

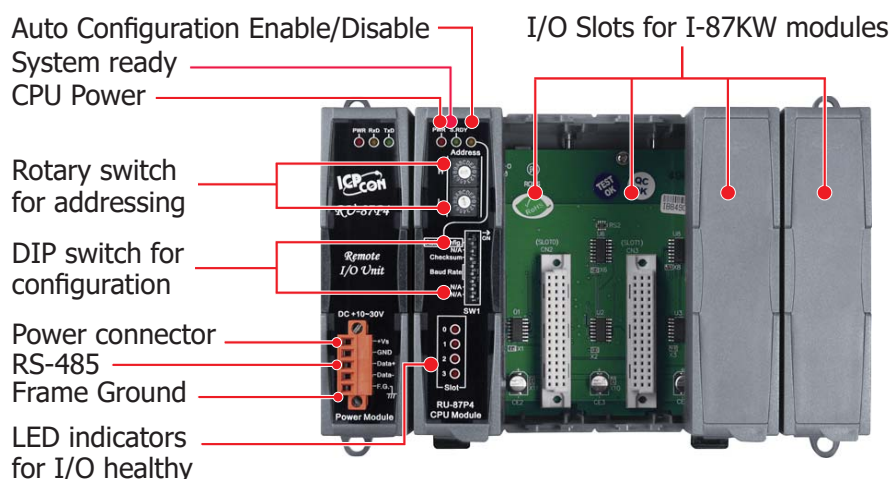

Ordering Information:

Model No.	Description
RU-87P1-G CR	1 slot I/O Expansion Unit (RoHS)
RU-87P2-G CR	2 slots I/O Expansion Unit (RoHS)
RU-87P4-G CR	4 slots I/O Expansion Unit (RoHS)
RU-87P8-G CR	8 slots I/O Expansion Unit (RoHS)

2

Secure Ethernet I/O Products

- 2.1 ETS-7200 Secure Ethernet I/O Modules- - - - - P 27
- 2.2 ETS-8KPn Secure Ethernet I/O Expansion Units - - - - P 34
- 2.3 U-7500M OPC UA I/O Modules - - - - - P 40

2.1 ETS-7200 Secure Ethernet I/O Modules



The ETS-7200 modules support RESTful API and Industrial IoT communication protocols, including Modbus and MQTT client. These modules are designed with comprehensive cybersecurity mechanisms, such as support for SSL/TLS certificates for encryption, to ensure that sensor data is transmitted securely and protected from unauthorized access.

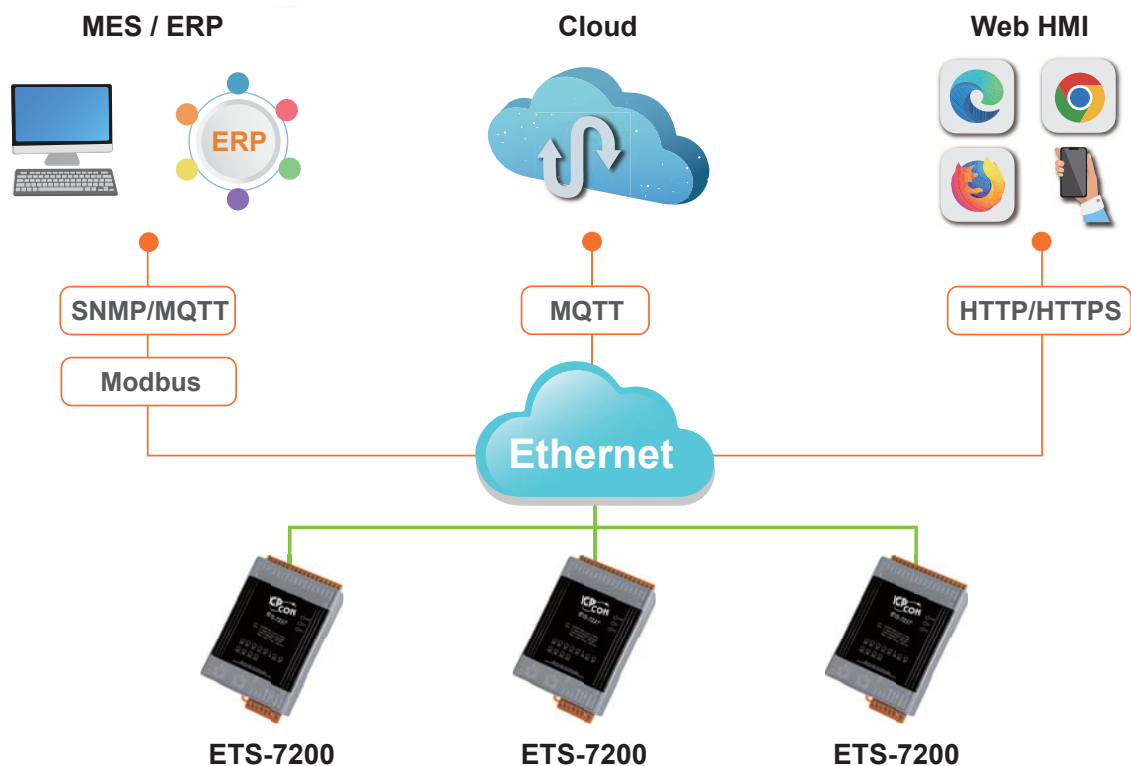

The ETS-7200 provides an IP address filter function with an allow-list, blocking all other access, thereby reducing the risk of unauthorized access and enhancing security. The Netstat feature provides real-time monitoring of connection status for listening TCP ports and connected clients. Equipped with various types of I/O, the module also has a built-in web server (HTTP/HTTPS) that allows users to configure, monitor and control I/O directly via a web browser, making it ideal for remote control applications.



Features

❖ SSL/TLS Encryption for Ensured Security and Data Protection

SSL/TLS uses certificates and a public-key infrastructure (PKI) to authenticate the identities of both the server and the client, ensuring a secure connection and protecting against man-in-the-middle (MITM) attacks. All data transmitted is encrypted, preventing unauthorized access or modification. The ETS-7200 modules support SSL/TLS, offering continuous security from initial configuration to online operation. They provide comprehensive protection for communications, ensuring that data remains private, intact, and authentic, making the module ideal for building secure systems.

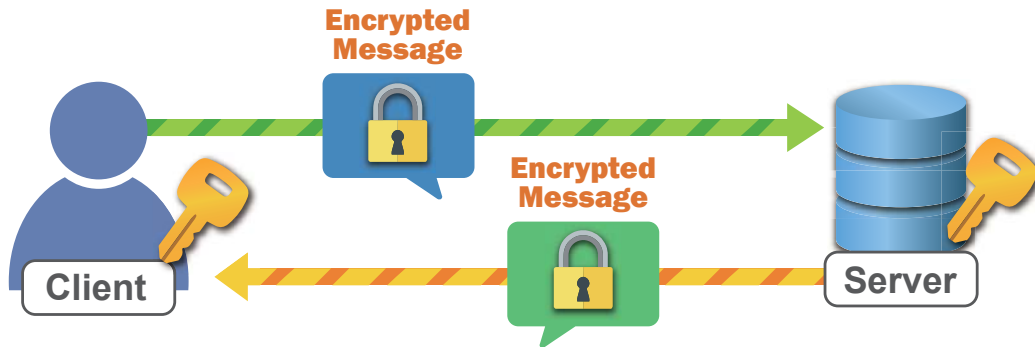

❖ Support MQTT and Modbus for Flexible System Integration

Support both the MQTT client (compliant with the MQTT V3.1.1 protocol) and the widely used Modbus TCP protocol for industrial automation. These protocols work simultaneously, providing flexibility and simplifying system integration. This enables seamless remote monitoring and control via SCADA systems or IIoT platforms. By incorporating SSL/TLS protocols into both MQTT and Modbus TCP communications, we enhance security, ensuring that data transmitted across networks is protected against unauthorized access and potential cyber threats.

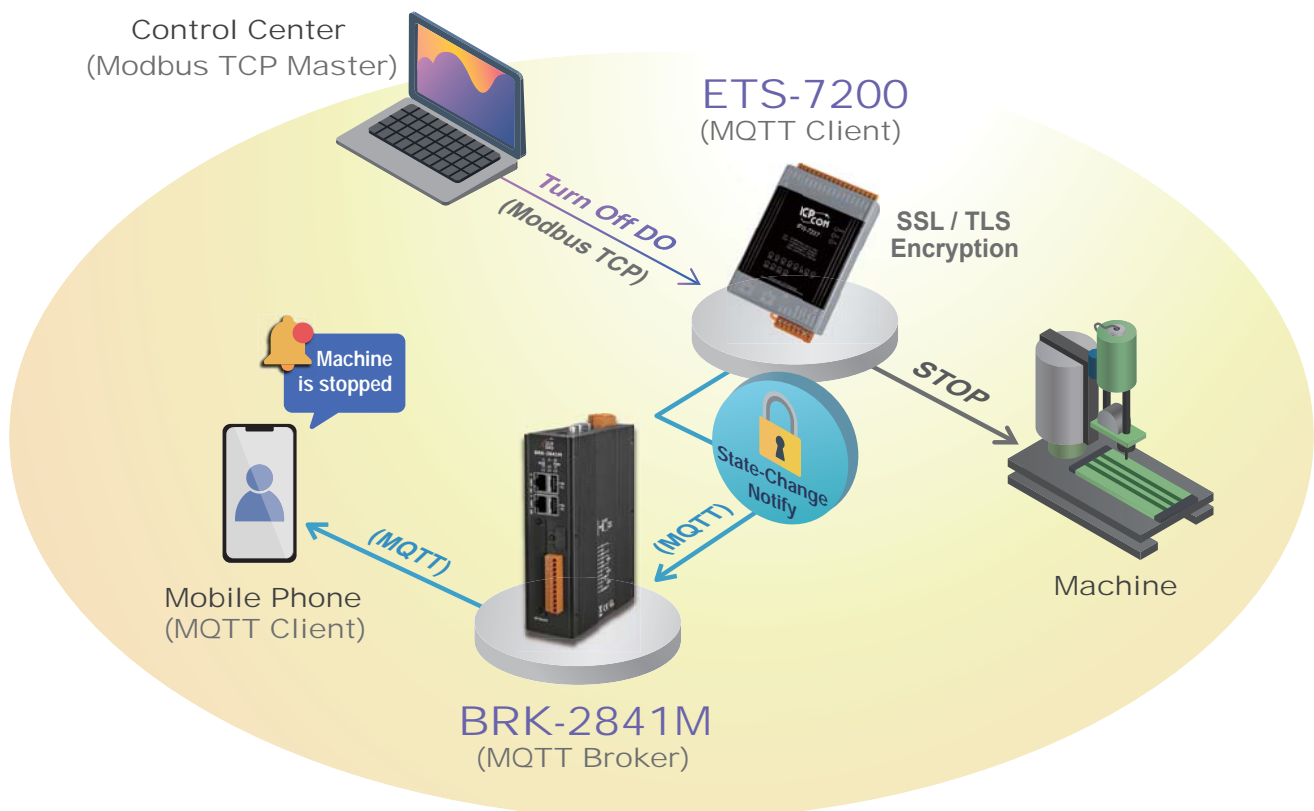

❖ Denial-of-Service (DoS/DDoS) Attack Defense

Equipped with robust defense mechanisms, the ETS-7200 protects against DoS and DDoS attacks. It actively regulates network traffic to reduce the impact of large volumes of abnormal network packets on Ethernet operations, ensuring that the module remains functional and reliable.



❖ IPv4/IPv6 Dual-Protocol for Flexible Network Configuration

The module incorporates dual-stack technology for effective communication over both IPv4 and IPv6 networks. Users can operate without additional configuration because the system automatically evaluates packet sources to determine the appropriate network protocol. With SLAAC (Stateless Address Autoconfiguration), the module automatically requests IP information from the router, eliminating the need to manually set complex IPv6 addresses and ensuring seamless connectivity.

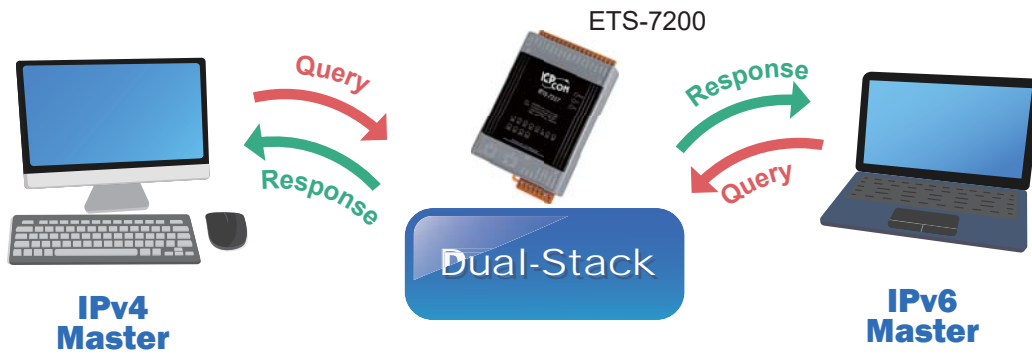

❖ mDNS Hostname Resolution for Easy Connection

The ETS-7200 modules support the mDNS (Multicast DNS) protocol, allowing easy-to-remember domain names (e.g., EthernetIO.local) for local network communication with compatible browsers and software. Whether the module operates with static or dynamic IP addresses, users can maintain communication through the fixed mDNS domain name, helping to prevent problems associated with IP address changes.

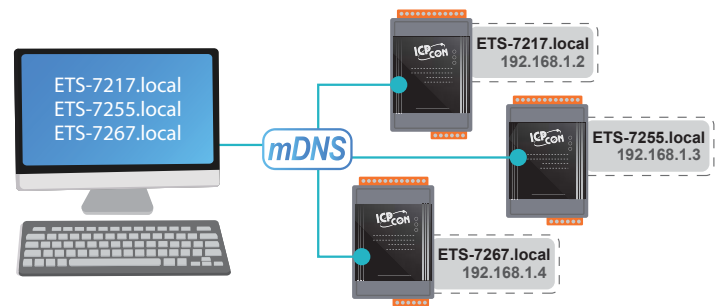

❖ Rule Logic Engine for Streamlined Edge Control

Built-in logic engine that supports IF-THEN-ELSE rules to make decisions with physical I/O and software points. This capability enables stable and efficient execution of automated monitoring tasks. The logic engine also supports encrypted and unencrypted e-mail notifications to efficiently notify relevant personnel when specific events occur.



❖ 802.1Q and 802.1p Tagging for Prioritized Network Transmission

Supporting 802.1Q and 802.1p priority tagging, the ETS-7200 module tags data frames on selected network protocols for use with 802.1Q compliant switches. In environments with limited network bandwidth, this configuration effectively preserves network resources for time sensitive network communication, ensuring low-latency and high-reliability transmission.

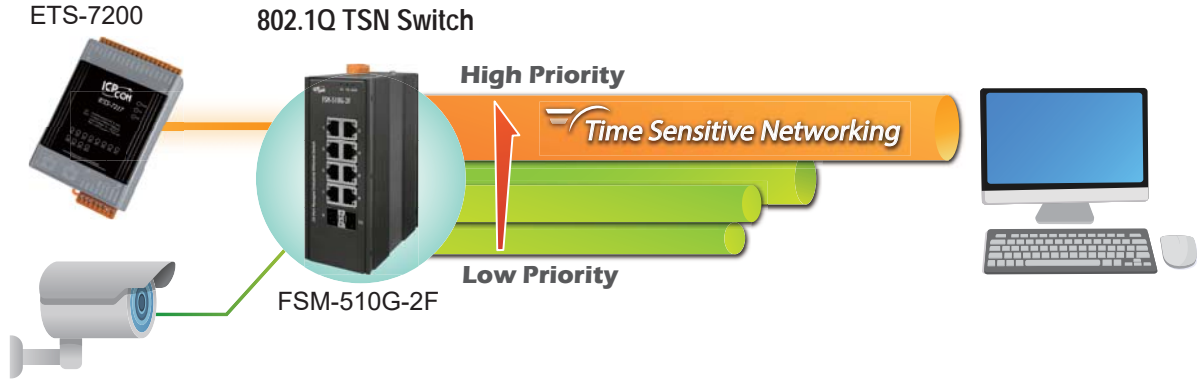

❖ Ethernet Daisy-Chain Cabling with LAN Bypass

Include a 2-port Ethernet switch that supports a daisy-chain network topology. This topology simplifies wiring, reduces maintenance complexity and lowers both wiring and maintenance costs, while increasing network scalability. In addition, the module is equipped with a LAN bypass function that ensures stable Ethernet communication. If a module loses power, this function is automatically activated to maintain seamless network connectivity.

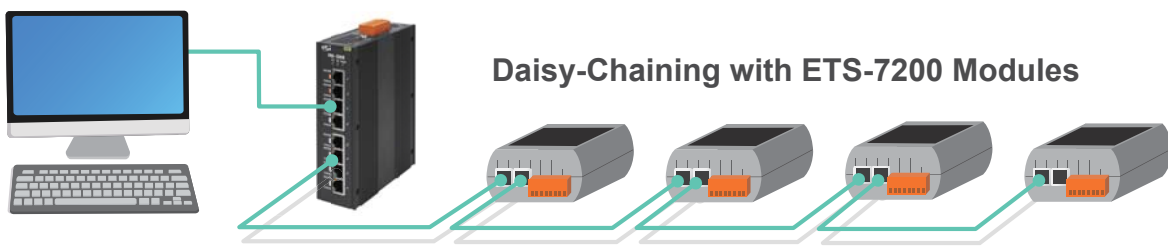
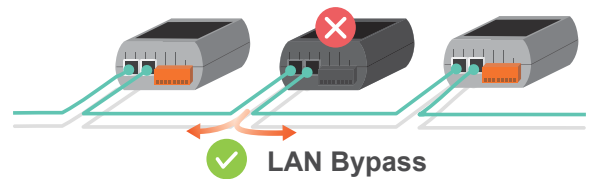

Daisy-Chaining with ETS-7200 Modules

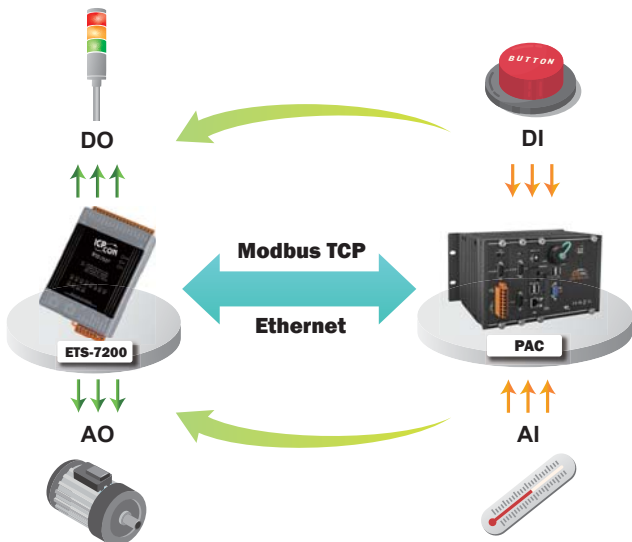

❖ Built-in Various I/O Functions

Support various I/O types, including optically isolated digital inputs, power relays, PhotoMOS relays, and open-collector outputs. The I/O Pair-Connection function establishes mirrored input-to-output pairs over Ethernet, enabling bidirectional data exchange between the local module and remote devices. Once configured, the module automatically transfers data between their respective paired I/O channels via Modbus TCP.

❖ Fast Boot (< 5 Seconds) for Immediate Operation

The module powers up and becomes fully operational in less than 5 seconds, ensuring immediate system availability. This rapid startup enhances productivity, reduces delays in critical applications, and improves workflow efficiency. By enabling a quick reboot after power cycles or unexpected shutdowns, it minimizes downtime and enhances the overall user experience.



❖ Dual Watchdog with Power-on and Safe Values

To ensure system reliability, stability, and continuous operation, this module incorporates a Dual Watchdog design. The hardware watchdog automatically resets the MCU if it detects a module freeze, preventing it from stopping working. This reset loads the AO/DO values according to user-defined power-on settings. The software watchdog monitors communication activity between the host controller and the module. If the watchdog timeout occurs, the module switches its outputs to predefined safe values to prevent incorrect operation.

❖ Seamless Device Interaction via a RESTful API

Supports reading and writing of I/O and virtual points over HTTP, with HTTPS ensuring secure, encrypted communications. This feature enables secure data transmission, facilitates remote access for seamless device interaction, and offers cross-platform compatibility. Additionally, it provides scalability for system growth and simplifies integration.



More Features

- All DI's Act as 32-bit Counters (100 Hz)
- 16-bit High Resolution ADC for Analog Inputs
- 240 Vrms Overvoltage Protection for Analog Inputs
- Channel-to-Channel Isolation (400 VDC) for Analog Inputs
- Rugged Design with up to 3000 VDC Field-to-Logic Isolation
- Open Wire Detection for Enhanced System Safety (ETS-7219Z)
- Fast Boot (< 5 Seconds) for Immediate Operation
- Lower Power Consumption for Energy Saving
- Power Reverse Polarity Protection for Safety
- Wide Power Input Range (+12 to +48 VDC)
- Wide Operating Temperature (-25 to +75°C)
- DIN-Rail Mounting for Stable Installation
- Short-Circuit Protection on Digital Outputs
- Overvoltage Protection on Digital I/O
- LED for I/O Status Monitoring and Diagnostics
- Terminal Block for Easy and Stable I/O Wiring
- Reset Button to Easily Restore Factory Settings
- Two Pairs (4 Pins) of Power Inputs for Easy Daisy-Chain Wiring
- Up to 4kV Contact ESD Protection on Terminals

Applications

Securing smart traffic light systems

Smart traffic lights, or intelligent traffic lights, are vehicle traffic control systems that combine traditional traffic signals with a range of sensors and artificial intelligence to intelligently balance vehicle and pedestrian traffic. They can be part of a larger smart transportation system and securing smart traffic light systems is crucial for safeguarding smart city infrastructure against Cyberattacks.



ETS-7200 provides a one-stop Cybersecurity solution that supports encrypted transmissions such as HTTPS, Modbus and MQTT with SSL/TLS. It effectively safeguards data security, preventing data theft or tampering, meeting the Cybersecurity requirements of smart traffic system deployment.

Zero-configuration and mDNS

Obtaining a static IP address may not always be possible in an IT/OT converged network environment. The Multicast Domain Name System (mDNS) protocol is a zero-configuration, multi-platform service designed to resolve hostnames to IP address on networks without relying on static IP address. The host can access the ETS-7200 via its hostname (e.g., ETS-7200.local), eliminating concerns about communication being affected by IP changes. Zero-configuration networking allows Industrial Ethernet to automatically establish device networks without manually configuring a DHCP server, DNS services, or network settings for each device connecting to the network. This simplifies network management, reduces the risk of errors, and increases operational efficiency.

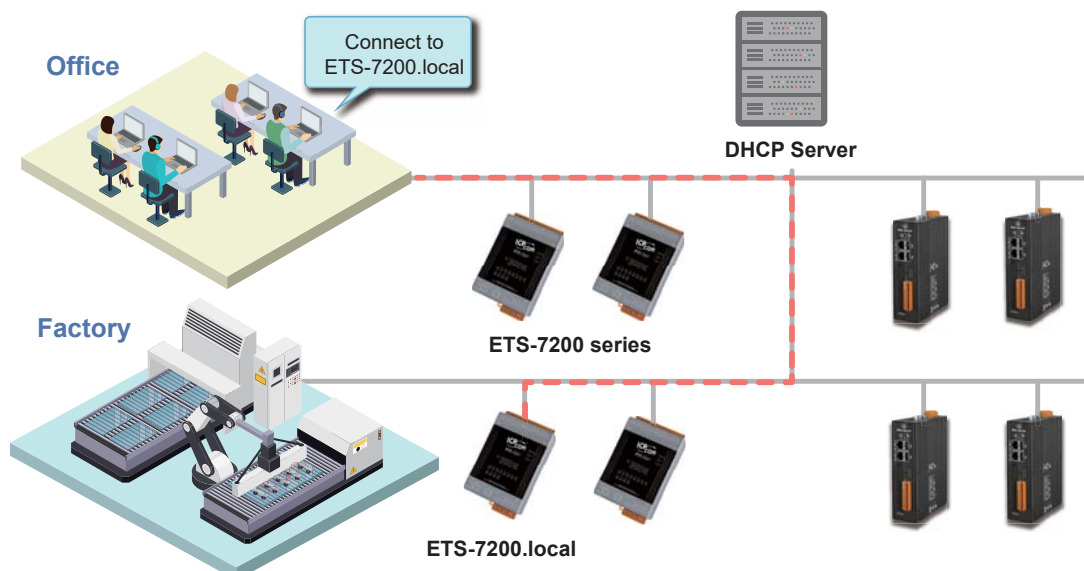

Selection Guide

Analog Input

Model Name	AI			DO		
	Ch.	Voltage & Current Input	Sensor Input	Ch.	Type	Sink/Source (NPN/PNP)
ETS-7217	8	± 150 mV, ± 500 mV, ± 1 V, ± 5 V, ± 10 V, ± 20 mA, 0 ~ 20 mA, 4 ~ 20 mA	-	4	Open Collector	Sink (NPN)
ETS-7215	7	-	RTD: Pt100, Pt1000, Ni120, Cu100, Cu1000	-	-	-
ETS-7218Z/S	10	± 15 mV, ± 50 mV, ± 100 mV, ± 500 mV, ± 1 V, ± 2.5 V ± 20 mA, 0~20 mA, 4~20 mA	Thermocouple J, K, T, E, R, S, B, N, C, L, M, LDIN43710	3	Open Collector	Sink (NPN)
ETS-7219/S	10	± 15 mV, ± 50 mV, ± 100 mV, ± 150 mV, ± 500 mV, ± 1 V, ± 5 V, ± 10 V, ± 20 mA, 0~20 mA, 4~20 mA	Thermocouple J, K, T, E, R, S, B, N, C, L, M, LDIN43710	3	Open Collector	Sink (NPN)

Multifunction I/O

Model Name	AI			AO		DI/Counter		DO	
	Ch.	Voltage & Current Input	Sensor Input	Ch.	Voltage & Current Output	Ch.	Type	Ch.	Type
ETS-7226	6	± 500 mV, ± 1 V, ± 5 V, ± 10 V, 0 ~ 20 mA, ± 20 mA, 4~20mA	-	2	0 ~ 5 V, ± 5 V, 0 ~ 10 V, ± 10 V, 0 ~ 20 mA, 4 ~ 20 mA	2	Dry (Source), Wet (Sink,Source)	2	Open Collector (Sink)

Digital I/O

Model Name	DI			DO			
	Ch.	Type	Sink/Source (NPN/PNP)	Ch.	Type	Sink/Source (NPN/PNP)	Max. Load Current @ 25 °C
ETS-7255	8	Dry, Wet	Sink (NPN)	8	Open Collector	Source (PNP)	650 mA/channel

Relay Output & Digital Input

Model Name	Relay Output				DI		
	Ch.	Relay	Type	Max. Load Current @ 25°C	Ch.	Type	Sink/Source (NPN/PNP)
ETS-7260	6	Power Relay	Form A (SPST N.O.)	5.0 A/channel	6	Wet	Sink/Source (NPN/PNP)
ETS-7267	8	Power Relay	Form A (SPST N.O.)	5.0 A/channel	-	-	-

2.2 ETS-8KPn Secure Ethernet I/O Expansion Units



ETS-8KP4/ETS-8KP8 are secure Ethernet I/O expansion units that provide 4/8 slots for expanding I-8KW and I-87KW I/O modules (see Chapter 5.2) via Ethernet. The units support 100+ I/O modules, including analog input/output, digital input/output, and DI counter modules. To simplify installation and maintenance, they offer automatic I/O module configuration and LED indicators for fault detection. Dual watchdogs enhance system reliability and stability by providing specified safety value outputs if the connection is lost and allowing configurable power-on values at startup.

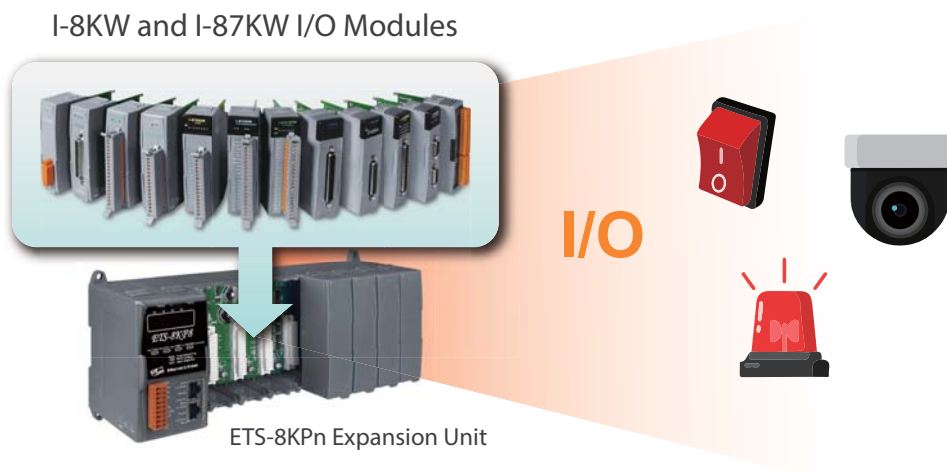

The secure Ethernet I/O expansion units include multiple security protection mechanisms for comprehensive industrial communication protection. They support various industrial IoT communication protocols, including Modbus, OPC UA Server/Client, MQTT Client, and LwM2M Client. Additionally, they offer TLS/DTLS communication certificates and encryption mechanisms to safeguard valuable data and devices from theft or tampering during transmission.

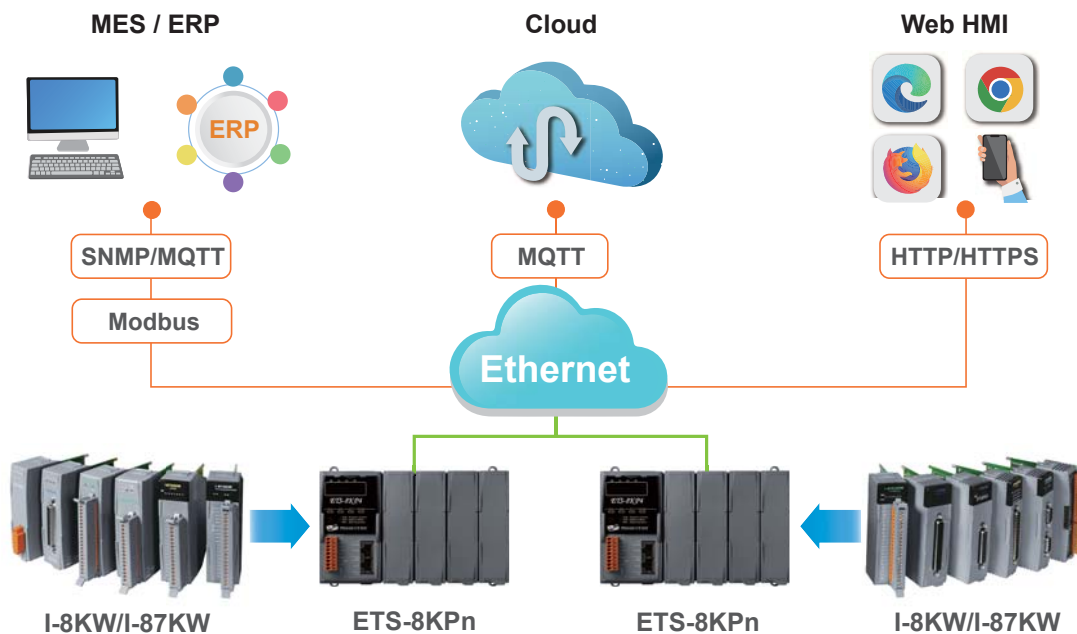

Designed for use in harsh and noisy environments, the hardware supports a wide power input range (10–30 VDC), isolated power input, and wide operating temperatures (-25 to +75°C).

Features:

❖ SSL/TLS Encryption for Ensured Security and Data Protection

SSL/TLS uses certificates and a public-key infrastructure (PKI) to authenticate the identities of both the server and the client, ensuring a secure connection and protecting against man-in-the-middle (MITM) attacks. All data transmitted is encrypted, preventing unauthorized access or modification. The ETS-8KPn units support SSL/TLS, offering continuous security from initial configuration to online operation. They provide comprehensive protection for communications, ensuring that data remains private, intact, and authentic, making the module ideal for building secure systems.

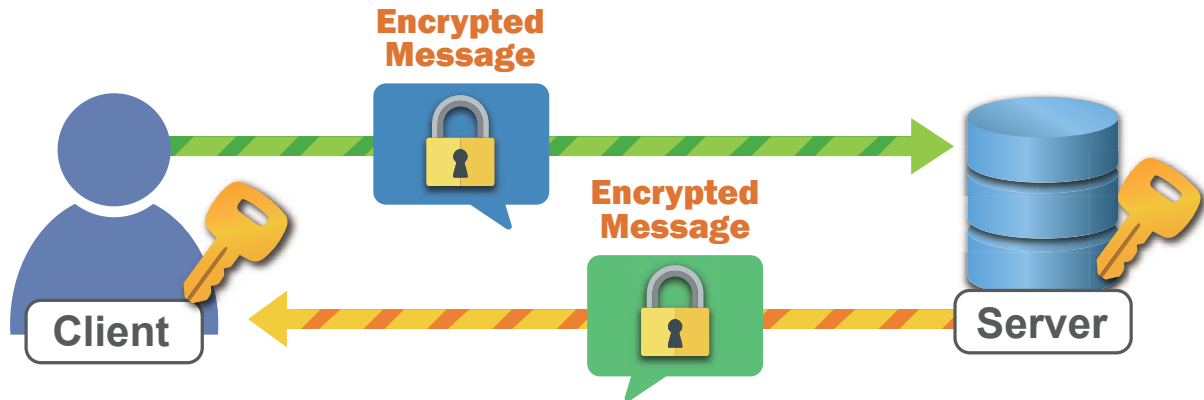

❖ Support MQTT and Modbus for Flexible System Integration

Our system supports both MQTT (compliant with MQTT V3.1.1) and the widely used Modbus TCP protocols, enabling simultaneous operation for flexible and simplified integration in industrial automation. This dual-protocol support facilitates seamless remote monitoring and control via SCADA systems or IIoT platforms. By incorporating SSL/TLS protocols into both MQTT and Modbus TCP communications, we enhance security, ensuring that data transmitted across networks is protected against unauthorized access and potential cyber threats.

❖ Denial-of-Service (DoS/DDoS) Attack Defense

Equipped with robust defense mechanisms, the ETS-8KPn unit protects against DoS and DDoS attacks. It actively regulates network traffic to reduce the impact of large volumes of abnormal network packets on Ethernet operations, ensuring that the unit remains functional and reliable.

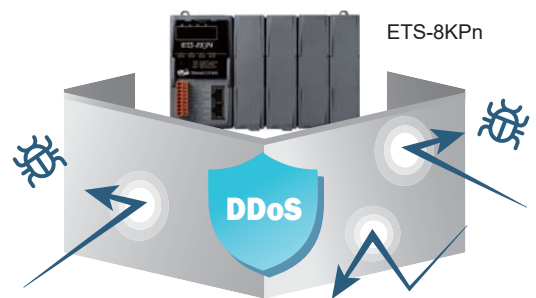

❖ IPv4/IPv6 Dual-Protocol for Flexible Network Configuration

The unit incorporates dual-stack technology for effective communication over both IPv4 and IPv6 networks. Users can operate without additional configuration because the system automatically evaluates packet sources to determine the appropriate network protocol. With SLAAC (Stateless Address Autoconfiguration), the module automatically requests IP information from the router, eliminating the need to manually set complex IPv6 addresses and ensuring seamless connectivity.

❖ mDNS Hostname Resolution for Easy Connection

The ETS-8KPn units support the mDNS (Multicast DNS) protocol, allowing easy-to-remember domain names (e.g., EthernetIO.local) for local network communication with compatible browsers and software. Whether the unit operates with static or dynamic IP addresses, users can maintain communication through the fixed mDNS domain name, helping to prevent problems associated with IP address changes.

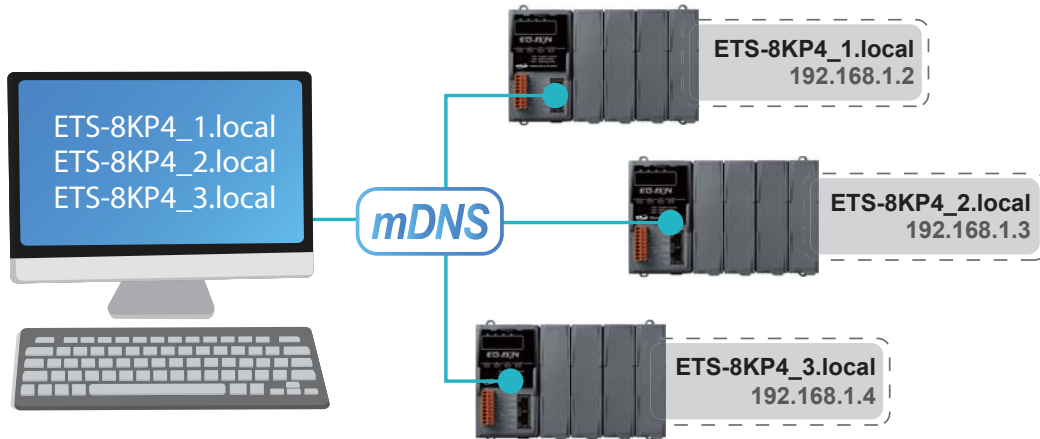

❖ Rule Logic Engine for Streamlined Edge Control

Built-in logic engine that supports IF-THEN-ELSE rules to make decisions with physical I/O and software points. This capability enables stable and efficient execution of automated monitoring tasks. The logic engine also supports encrypted and unencrypted e-mail notifications to efficiently notify relevant personnel when specific events occur.



❖ 802.1Q and 802.1p Tagging for Prioritized Network Transmission

Supporting 802.1Q and 802.1p priority tagging, the ETS-8KPn unit tags data frames on selected network protocols for use with 802.1Q compliant switches. In environments with limited network bandwidth, this configuration effectively preserves network resources for time sensitive network communication, ensuring low-latency and high-reliability transmission.

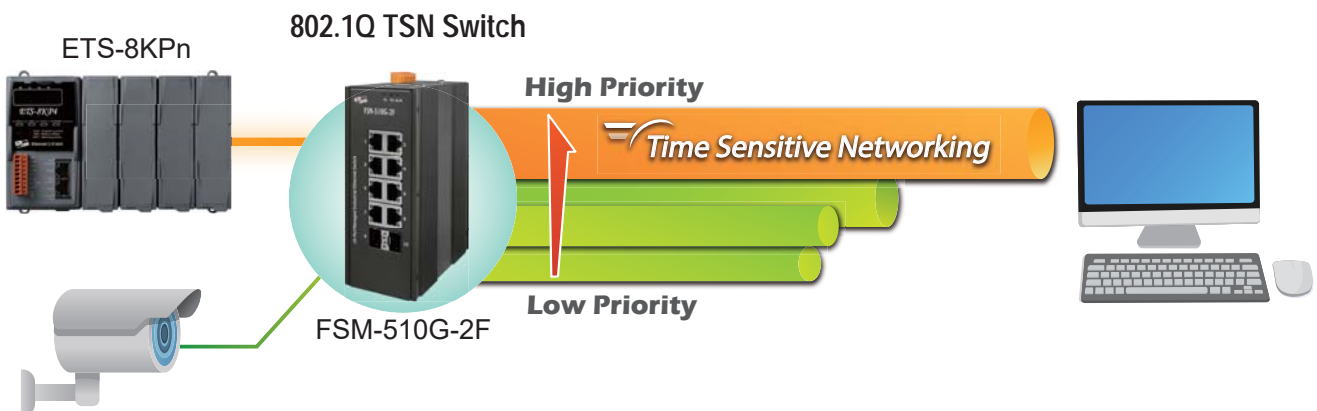

❖ Ethernet Daisy-Chain Cabling with LAN Bypass

Include a 2-port Ethernet switch that supports a daisy-chain network topology. This topology simplifies wiring, reduces maintenance complexity and lowers both wiring and maintenance costs, while increasing network scalability. In addition, the unit is equipped with a LAN bypass function that ensures stable Ethernet communication. If a unit loses power, this function is automatically activated to maintain seamless network connectivity.

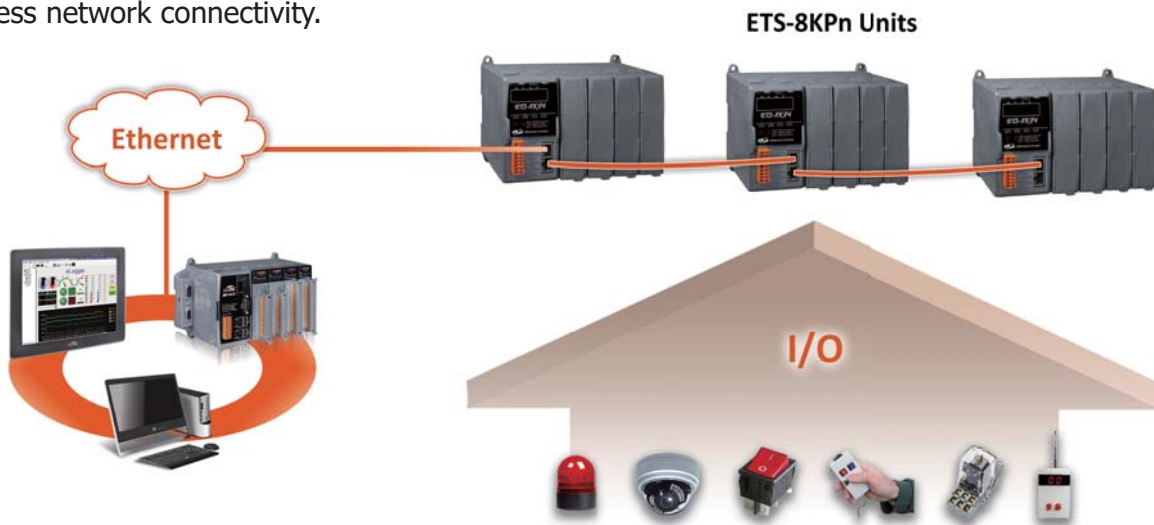

❖ Dual Watchdog with Power-on and Safe Values

To ensure system reliability, stability, and continuous operation, this module incorporates a Dual Watchdog design. The hardware watchdog automatically resets the MCU if it detects a module freeze, preventing it from stopping working. This reset loads the AO/DO values according to user-defined power-on settings. The software watchdog monitors communication activity between the host controller and the module. If the watchdog timeout occurs, the module switches its outputs to predefined safe values to prevent incorrect operation.

❖ Seamless Device Interaction via a RESTful API

Supports reading and writing of I/O and virtual points over HTTP, with HTTPS ensuring secure, encrypted communications. This feature enables secure data transmission, facilitates remote access for seamless device interaction, and offers cross-platform compatibility. Additionally, it provides scalability for system growth and simplifies integration.

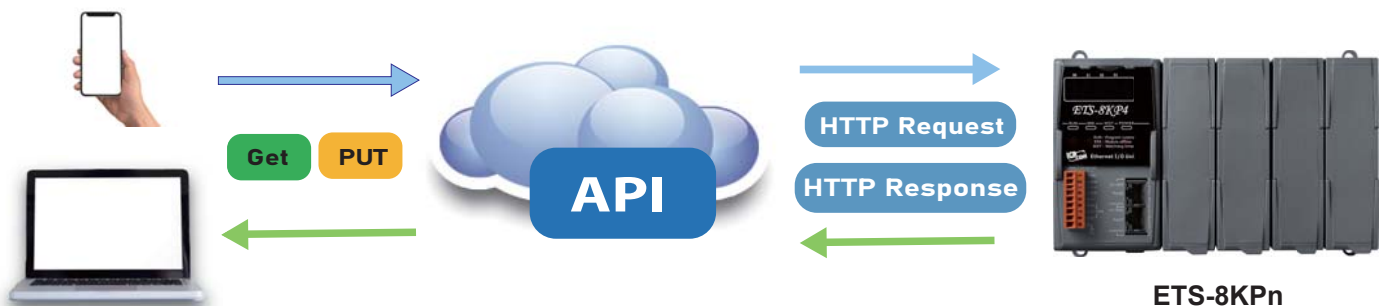

❖ Single Connection to Access Multiple I/O Channels

The expansion unit can manage multiple inputs and outputs simultaneously. All I/O channels on the installed modules are accessible through a single TCP connection, eliminating the need to poll each module via separate IP addresses. This setup improves system performance, increases network efficiency, and reduces overhead.

❖ Scalable I/O Capacity Supporting Up to 256 Digital Channels

The expansion unit supports up to 256 digital I/O channels, 160 analog inputs (AI), and 64 analog outputs (AO) in a compact form factor. Users can customize their system by selecting the most appropriate modules to meet their specific needs, providing flexible and extensive I/O capacity for a variety of applications. This scalability allows the system to accommodate large and complex industrial automation setups.

❖ Fast Boot (< 5 Seconds) for Immediate Operation

The expansion unit powers up and becomes fully operational in less than 5 seconds, ensuring immediate system availability. This rapid startup enhances productivity, reduces delays in critical applications, and improves workflow efficiency. By enabling a quick reboot after power cycles or unexpected shutdowns, it minimizes downtime and enhances the overall user experience.



❖ Concurrent Access via Multiple Modbus TCP Masters

It supports concurrent access from multiple computers or controllers, greatly improving I/O system scalability. This enables more comprehensive monitoring, control, and diagnostics in automation systems, improving overall system performance and responsiveness, especially in complex or large-scale applications.

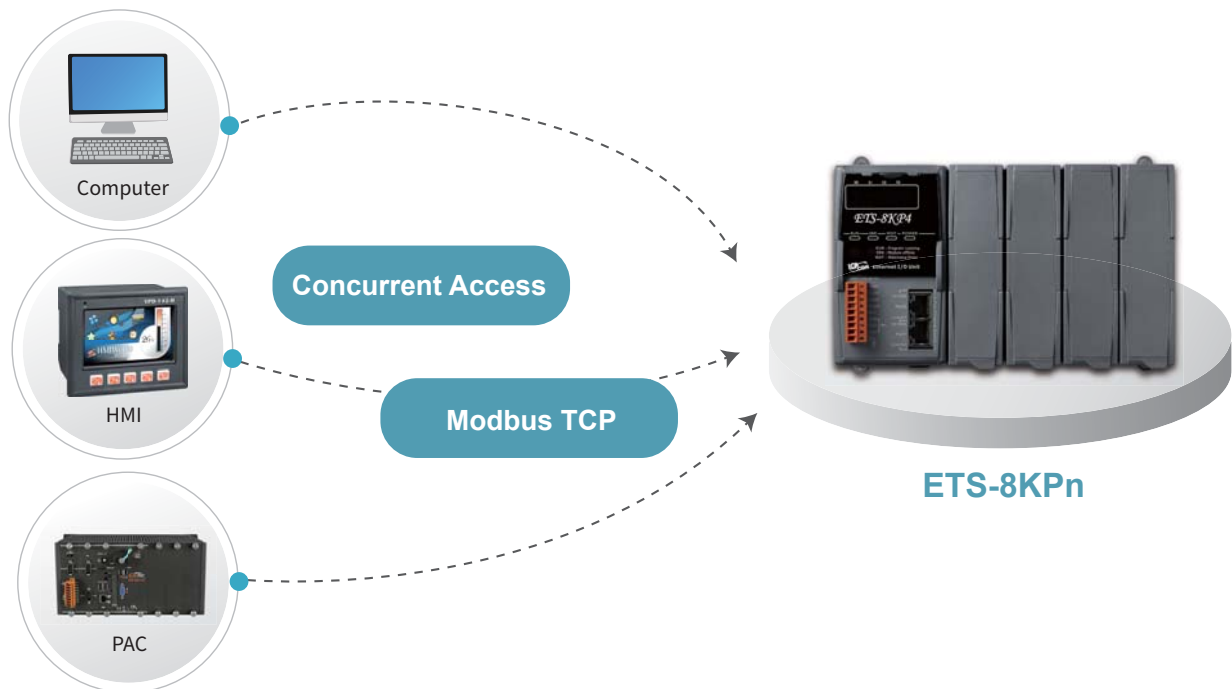

❖ Modbus Gateway and Virtual COM (VxComm)



The expansion unit supports Modbus TCP and Modbus RTU protocol conversion through the Modbus Gateway function, simplifying device integration without the need for additional protocol converters or gateways, reducing overall costs. It also supports access to devices via raw data communication through Virtual COM (VxComm), increasing compatibility across a wide range of systems and devices and improving system flexibility.

Application

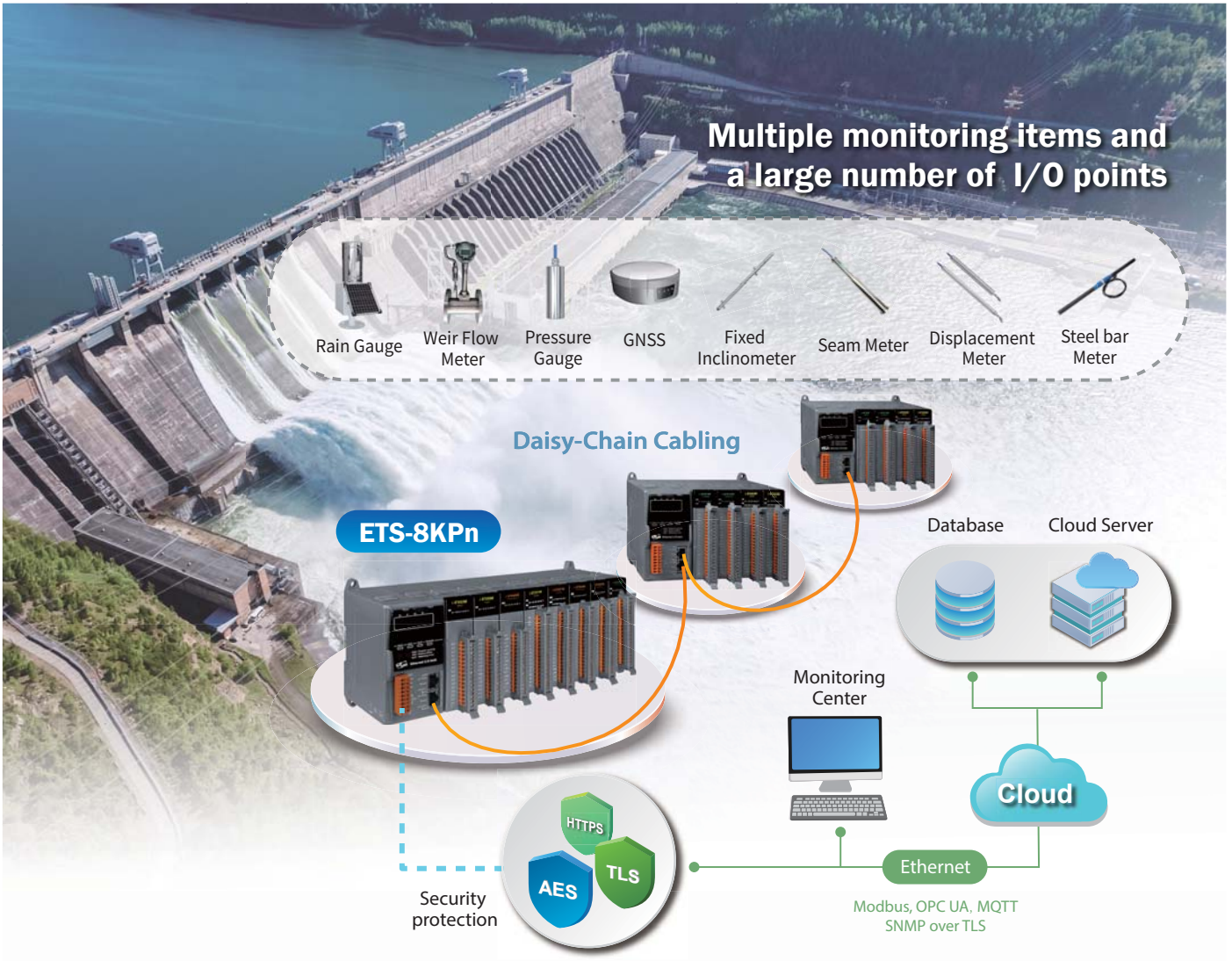
A dam monitoring system needs to cover a wide area and various monitoring parameters, requiring a large number of I/O points to connect different sensors such as rain gauges, pressure gauges, GNSS, and inclinometers. Data is collected and processed by the ETS-8KPn module and transmitted via Daisy-Chain cabling. The collected data is transmitted to the monitoring center or uploaded to a cloud server using Modbus, OPC UA, MQTT, and SNMP protocols, with security protection mechanisms such as TLS and HTTPS.



Selection Guide

Model	Ethernet	Protocol	I/O Slot	I-8KW series	I-87KW series	I/O Hot Swap	COM Port
 ETS-8KP4	2 (10/100 M) - Switch Ports - 1 IP Address	Modbus TCP	4	Yes	Yes	-	1
 ETS-8KP8			8				

2.3 U-7500M OPC UA I/O Modules



OPC UA (OLE for Process Control Unified Architecture) is a secure, scalable communication solution essential for modern industrial systems. Its built-in encryption and authentication mechanisms ensure data integrity, while its flexible architecture supports various communication models, including client/server, publish/subscribe, and peer-to-peer. This interoperability across vendors and systems provides a future-proof foundation for seamless industrial data integration.

The U-7500M OPC UA I/O modules (UA I/O) simplify system integration by supporting OPC UA Server, MQTT Client, and RESTful API protocols simultaneously. This versatility enables users to choose the optimal networking approach for their specific needs. Integrated I/O channel values can be seamlessly transmitted to both cloud IT systems (SCADA or data centers) and field OT systems (local control or edge computing). Analog signal scaling ensures data clarity and ease of interpretation. Built-in IF-THEN-ELSE logic rules allow users to define conditions and actions for both physical and virtual I/O points. Executing these rules at scheduled times enhances automation capabilities. Finally, the RESTful API provides easy data access (reading and writing of I/O and virtual point data) via HTTP or HTTPS.

Comparison: ICP DAS UA I/O Module v.s. Traditional I/O Module

Item	ICP DAS UA I/O Module		Traditional I/O Module
Protocol	OPC UA Server / Client	MQTT Client	Modbus TCP Slave
Identity Authentication	Account ID/Password, Anonymous, Certificate Verification	Account ID/Password, Anonymous, Certificate Verification	None
Encryption	SSL/TLS, Anonymous	SSL/TLS, Anonymous	None
Data Transmission	Active (Actively sends data to the client)	Active (Actively publishes data to broker, and the broker sends data to other clients)	Passive (Wait for master to poll the data: Query/Response)
Project Building	Browses server content	Subscribes topic from broker	Manually assigns ID, data address, and type.

OPC UA Architecture:

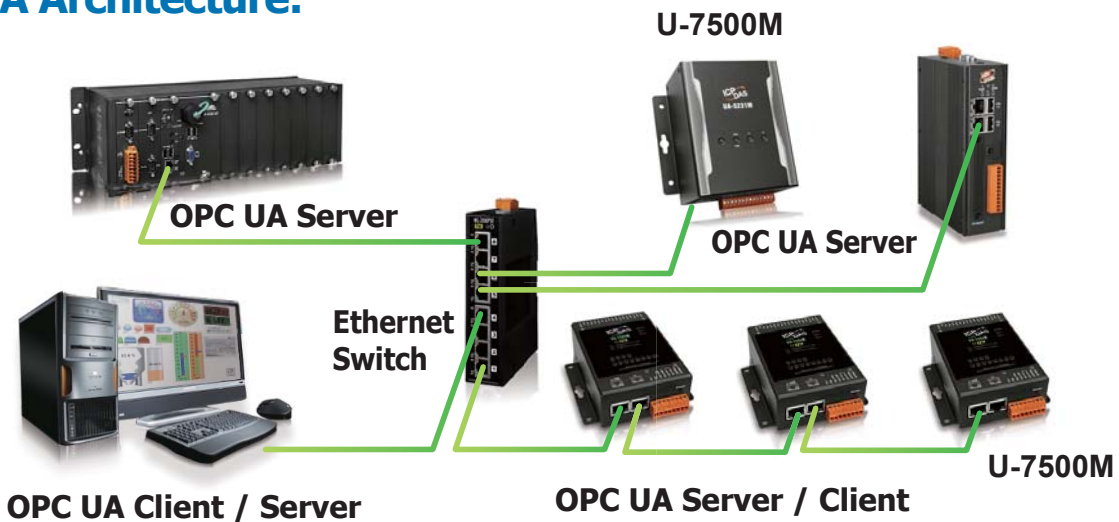

MQTT Architecture:

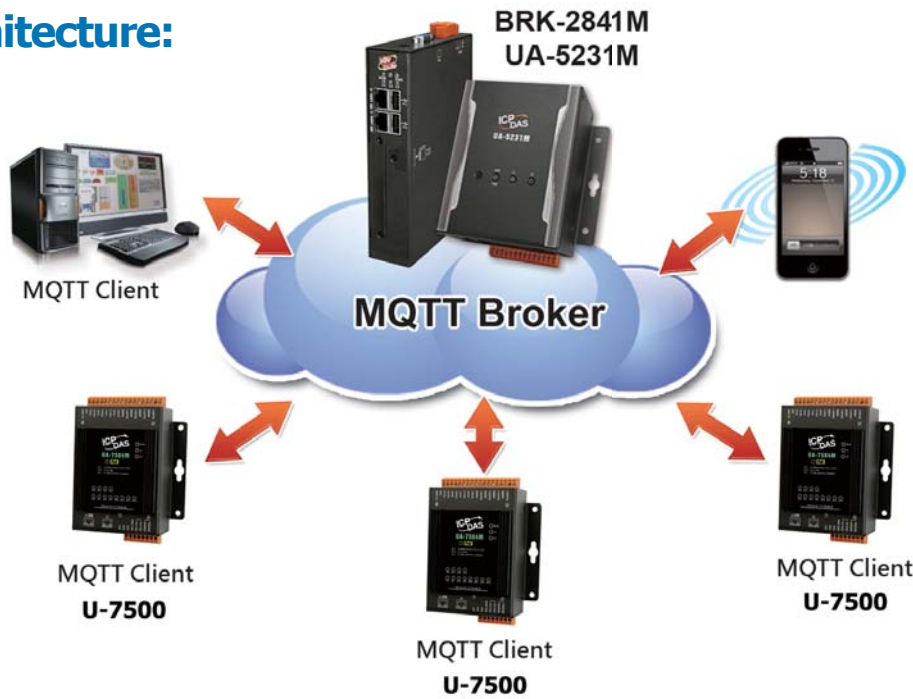

Features:

❖ Built-in OPC UA Server Service

Compliant with the IEC 62541 standard, this system provides robust communication features that allow SCADA and OPC UA clients to connect and exchange data. These features include Active Transmission, Transmission Security Encryption (SSL / TLS), User Authentication (X.509 Certificates / Account password), Communication Error Detection and Recovery, etc. For optimal performance, it is recommended to maintain a maximum of three concurrent client sessions.

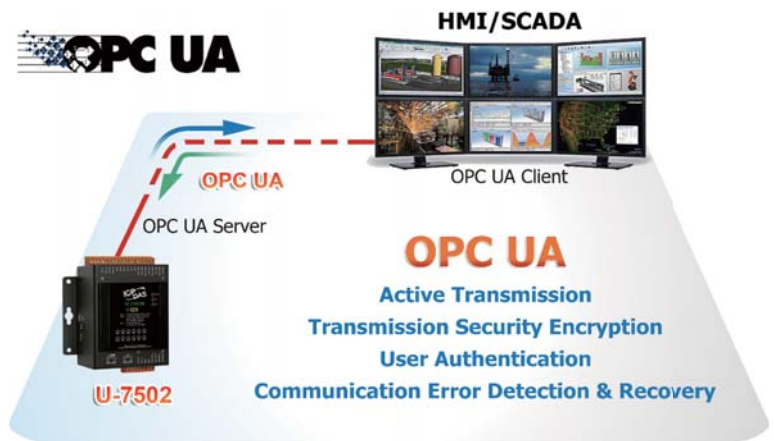

❖ Built-in OPC UA Client Service

Compliant with the IEC 62541 standard, this system ensures secure communication through Transmission Security Encryption (SSL/TLS) and User Authentication (X.509 Certificates / Account Passwords). It also offers OPC UA Server Connectivity, enabling seamless and secure data exchange between devices and applications.

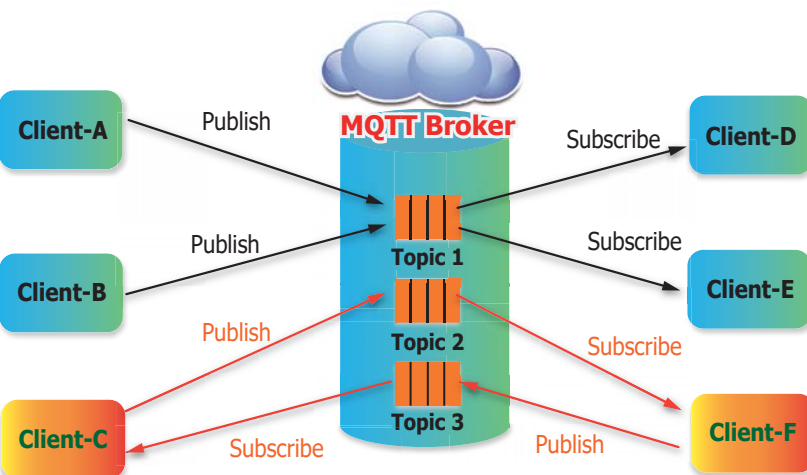

❖ Built-in MQTT Client Service

The built-in MQTT Client Service is compliant with MQTT V3.1.1, a lightweight messaging protocol designed for efficient, low-bandwidth communication in IoT and M2M (Machine-to-Machine) environments. It provides essential features such as QoS (Quality of Service), Retain Mechanism, Identity Authentication and Encryption, ensuring reliable and secure messaging for connected devices.

❖ Easy Device Interaction with RESTful API

Enables reading and writing of I/O and virtual points over HTTP, with HTTPS support for secure, encrypted communication. This feature provides secure data transmission, remote access for easy device interaction, and cross-platform compatibility. It also supports scalability for system growth and simplifies integration.

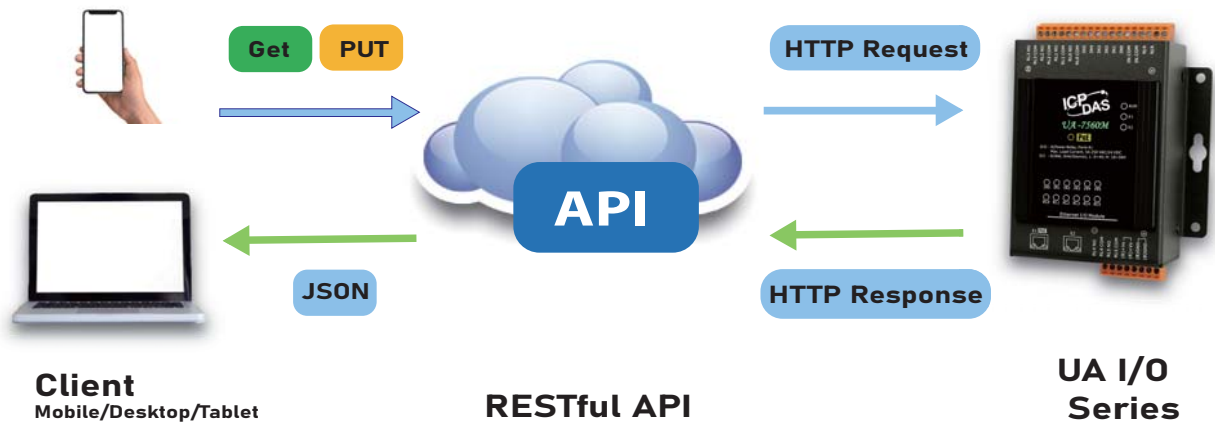

❖ Simultaneous Communication with OPC UA, MQTT, and RESTful API

Enables seamless integration across multiple protocols for IoT, industrial automation, and enterprise systems. This feature ensures flexible, secure, and real-time data exchange with a wide range of devices and platforms. Whether for real-time industrial control, remote IoT monitoring, or web-based application integration, the system provides reliable, efficient, and scalable communication in diverse environments.

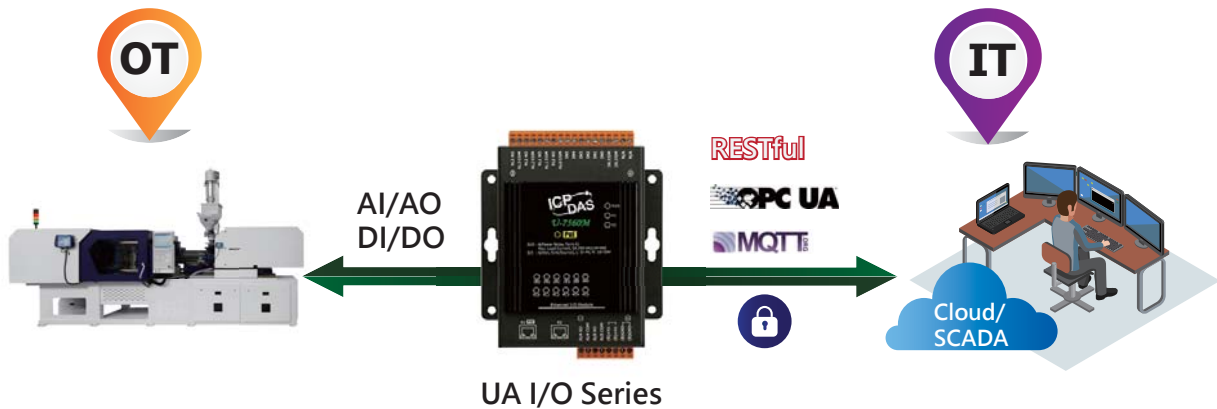

❖ Support for IoTstar Cloud Management Software

UA I/O firmware version 9.7 and later is compatible with IoTstar Cloud Management Software, enabling seamless integration for cloud-based monitoring and control.



❖ Scaling Function for Improved Readability

AI/AO modules support scaling, transforming analog signals into more readable values, enabling easier data interpretation and more accurate decision-making.

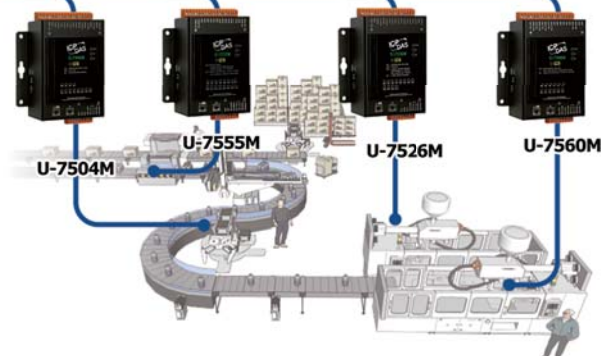

❖ Enhancing System Control with IF-THEN-ELSE Logic Rules

Allows users to define logical conditions and actions for both I/O and virtual points using IF-THEN-ELSE rules. This feature automates responses to changes in device states or conditions, removing the need for manual intervention. It enhances system responsiveness and decision-making by acting on real-time data. Whether applied to industrial processes or IoT device management, this functionality offers greater control and flexibility, adapting to a broad range of operational needs.

IF	THEN	ELSE
DI	DO	DO
DO	AO	AO
AI	Software Point	Software Point
AO	Delayed	Delayed
Software Point	IO Control	IO Control
	Gearing	Gearing

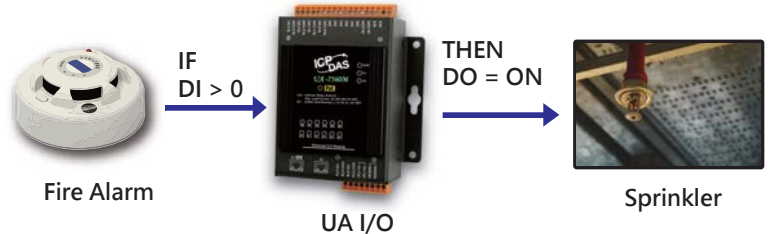

❖ Scheduled Rules Operation for Enhancing Productivity

Allows users to run predefined rules continuously within a specified time range, automating tasks, reducing manual intervention, minimizing errors, and significantly boosting productivity.

❖ Event Log for Quick Troubleshooting

Records the current I/O value as it changes, making it easy to track device activity and monitor changes over time. This historical data makes it easy to identify when problems occur, resulting in faster troubleshooting and reduced system downtime.

Specified Range

NO. Start Time End Time

Add Year Month Day Year Month Day

Hour Minute Second Hour Minute Second

Exclude

NO. Exclude Date

Add Year Month Day

Cycle

Week	Start Time	End Time	Display
Sunday	00:00	00:00	Disable
Monday	00:00	00:00	Disable
Tuesday	00:00	00:00	Disable
Wednesday	07:00	12:00	TI450-TI500 Enable
Thursday	00:00	00:00	Disable
Friday	00:00	00:00	Disable
Saturday	00:00	00:00	Disable

Range Scheduler

- Start Date : 2024/10
- Duration : three months
- Work Date : Monday~Friday
- Time Range : 07:00 - 12:00
13:00 - 17:00

Cycle Scheduler

- Work Date : Monday~Friday
- Time Range : 07:00 - 12:00
13:00 - 17:00

U-7502M

❖ Web-Based User Interface for Easy Device Management

The UA I/O Series features a built-in web server that provides an intuitive Web User Interface (Web UI) for module configuration, output channel control, and real-time monitoring of connection and I/O status—all accessible via a standard web browser. No additional applications are required, offering a simple and efficient solution for device management.

❖ Dual-port Ethernet Switch for Daisy-Chain Topology

It simplifies cabling with a daisy-chain topology, significantly reducing overall costs by eliminating the need for additional network switches as more devices are daisy-chained. This setup allows for easy network expansion with fewer switches, saving valuable installation space.



❖ IEEE 802.3af-compliant Power over Ethernet (PoE)

The UA I/O complies with the IEEE 802.3af (Classification, Class 2) Power over Ethernet (PoE) specification. This allows both data and power to be transmitted over a single Ethernet cable when connected to a PoE switch. This design enhances flexibility and efficiency by simplifying system architecture and reducing the need for additional cabling and power outlets.

Selection Guide:

Module	Analog I/O Modules							
	AI		AO		DI		DO	
	Ch.	Type	Ch.	Type	Ch.	Type	Ch.	Type
U-7502M	3	± 150 mV, ± 500 mV, ± 1 V, ± 5 V, ± 10 V, $+0$ mA \sim $+20$ mA, ± 20 mA, $4 \sim 20$ mA	-	-	6	Wet (Sink/Source)	3	Power Relay Form A (SPST N.O.)
U-7504M	4	± 500 mV, ± 1 V, ± 5 V, ± 10 V, $0 \sim 20$ mA, ± 20 mA, $4 \sim 20$ mA	4	$0 \sim 5$ V, ± 5 V, $0 \sim 10$ V, ± 10 V, $0 \sim 20$ mA, $4 \sim 20$ mA	4	Dry (Source), Wet (Sink)	-	-
U-7515M	7	Pt100, Pt1000, Ni120, Cu100, Cu1000	-	-	-	-	-	-
U-7517M	8	± 150 mV, ± 500 mV, ± 1 V, ± 5 V, ± 10 V, ± 20 mA, $0 \sim 20$ mA, $4 \sim 20$ mA	-	-	-	-	4	Isolated Open Collector (Sink)
U-7517M-10	10 / 20	± 150 mV, ± 500 mV, ± 1 V, ± 5 V, ± 10 V, ± 20 mA, $0 \sim 20$ mA, $4 \sim 20$ mA	-	-	-	-	-	-
U-7518ZM/S	10	± 15 mV, ± 50 mV, ± 100 mV, ± 500 mV, ± 1 V, ± 2.5 V, ± 20 mA, $0 \sim 20$ mA, $4 \sim 20$ mA Thermocouple: J, K, T, E, R, S, B, N, C, L, M, LDIN43710	-	-	-	-	3	Isolated Open Collector (Sink)
U-7518ZM/S2								
U-7519ZM/S	10	± 150 mV, ± 500 mV, ± 1 V, ± 5 V, ± 10 V, ± 20 mA, $0 \sim 20$ mA, $4 \sim 20$ mA Thermocouple: J, K, T, E, R, S, B, N, C, L, M, LDIN43710	-	-	-	-	3	Isolated Open Collector (Sink)
U-7519ZM/S2								
U-7524M	-	-	4	$0 \sim 5$ V, ± 5 V, $0 \sim 10$ V, ± 10 V, $0 \sim 20$ mA, $4 \sim 20$ mA	5	Dry (Source), Wet (Sink)	5	Isolated Open Collector (Sink)
U-7526M	6	± 1 V, ± 5 V, ± 10 V, ± 500 mV, ± 20 mA, $0 \sim 20$ mA, $4 \sim 20$ mA	2	$0 \sim 5$ V, ± 5 V, $0 \sim 10$ V, ± 10 V, $0 \sim 20$ mA, $4 \sim 20$ mA	2	Dry (Source), Wet (Sink)	2	Isolated Open Collector (Sink)
U-7528M	-	-	8	$0 \sim 5$ V, ± 5 V, $0 \sim 10$ V, ± 10 V, $0 \sim 20$ mA, $4 \sim 20$ mA	-	-	-	-

Module	Digital I/O Modules			
	DI		DO	
	Ch.	Type	Ch.	Type
U-7542M	-	-	16	Isolated Open Collector (Sink)
U-7544M	8	Wet (Sink,Source)	8	Isolated Open Collector (Sink)
U-7545M	-	-	16	Isolated Open Collector (Source)
U-7550AM	12	Dry (Source), Wet (Sink)	6	Isolated Open Collector (Sink)
U-7551M	16	Wet (Sink,Source)	-	-
U-7552M	8	Wet (Sink,Source)	8	Isolated Open Collector (Source)
U-7553M	16	Dry (Source)	-	-
U-7555M	8	Dry (Source), Wet (Sink,Source)	8	Isolated Open Collector (Source)
U-7558M	8	Wet (Sink/Source)	-	-
U-7559M	8	Wet (Sink/Source)	-	-
U-7560M	6	Wet (Sink/Source)	6	Power Relay Form A (SPST N.O.)
U-7561M	-	-	11	Power Relay Form A (SPST N.O.)
U-7567M	-	-	8	Power Relay Form A (SPST N.O.)



High-Speed Ethernet I/O Products

- 3.1 PET-7H16M/7H24M High-Speed DAQ Modules - - - - - P 46
- 3.2 DAS-8000 High-Speed Ethernet DAQ System - - - - - P 56

3.1 PET-7H16M/7H24M High-Speed DAQ Modules



Model	PET-7H24M	PET-7H16M
AI	4 Differential (Simultaneously) 24-bit A/D.	8 Single-ended (Simultaneously) 16-bit A/D.
AO	2	-
Encoder Input	32-bit	-
DI	3	4
DO	4	4
Counter Input	-	4 DI Counters (1KHz Max.) 1 High-speed Counter (30KHz Max.)
External Trigger	-	Yes

The **PET-7H16M** and **PET-7H24M** high-speed data acquisition modules feature a PoE port that supports both network data and power over a single Ethernet cable. The PET-7H16M provides 8 high-speed 16-bit single-ended analog inputs, each with a sampling rate of 200 kHz. The PET-7H24M provides 4 high-speed 24-bit differential analog inputs, each with a sampling rate of 128 kHz. All high speed data acquisition modules allow A/D signal conversion simultaneously on each channel and provide the programmable input range on all analog input channels. In addition to supporting Analog Input channels, the module also provides Digital Input/Digital Output/Counter/ Encoder with various combinations and different numbers of channels. The module provides 4 kV ESD protection as well as 2500 VDC isolation between logic and I/O circuits.

Features:

❖ Data Transmission Mode

1. Continuous Transmission

After starting A/D acquisition, data is continuously transmitted to the Host PC.

Model	Channels	Max. Sampling Rate per Channel
PET-7H16M	8-ch, Simultaneously	30 KHz
PET-7H24M	4-ch, Simultaneously	30 KHz

2. N-Sample Transmission

a. After starting A/D acquisition, data is temporarily stored in memory and transferred to the Host PC when a command is received.

b. The memory capacity allows temporary storage of up to 30 million data samples.

Model	Channels	Max. Sampling Rate per Channel
PET-7H16M	1 ~ 8-ch, Simultaneously	200 KHz
PET-7H24M	1 ~ 4-ch, Simultaneously	128 KHz

PET-7H16M/7H24M

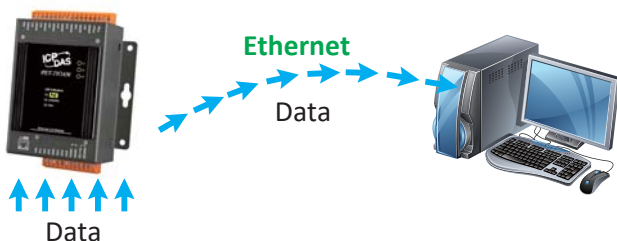

Mode 1: Continuous Transmission

PET-7H16M/7H24M

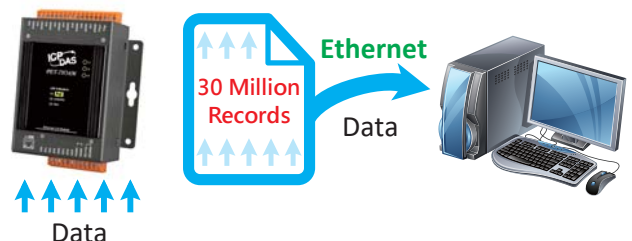

Mode 2: N-Sample Transmission

❖ A/D Trigger Mode

1. Software Trigger Mode

The A/D acquisition parameters are configured by commands from the Host PC. The N-sample or continuous data acquisition begins when a software command is received from the host PC.

2. Digital Event Trigger Mode (*Only for PET-7H16M)

The A/D acquisition parameters are configured by commands from the Host PC. The N-sample data acquisition begins when triggered by an external electrical signal.

3. Analog Threshold Trigger Mode

The A/D acquisition parameters are configured by commands from the Host PC. The N-sample data acquisition begins when the analog input value exceeds or enters the specified range.

4. External Clock Trigger Mode (*Only for PET-7H16M)

The rate and amount of data acquisition is controlled by external electrical signals, with each falling edge of the signal triggering an A/D conversion.

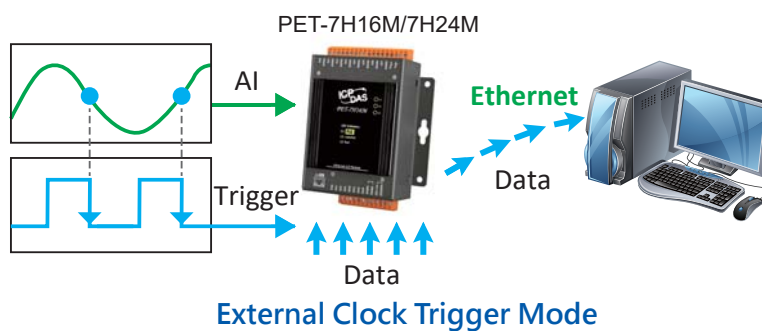

❖ Digital Event Trigger Modes (PET-7H16M)

A/D data acquisition uses three trigger modes, each activated by the falling edge of a digital input signal. The maximum sampling rate of each channel is 200 kHz, and N data samples are acquired and buffered in memory.

1. Pre-Trigger

Data acquisition proceeds until the trigger signal is detected. Once the trigger is received, acquisition stops and the stored data is transferred to the host PC.

2. Post-Trigger

Data acquisition starts immediately upon receiving the trigger signal. Acquisition stops once the specified number of samples is collected, and the data is transferred to the host PC.

3. Delay-Trigger

Data acquisition begins after a programmed delay period following the trigger signal. Acquisition stops once the specified number of samples is collected, and the data is transferred to the host PC.

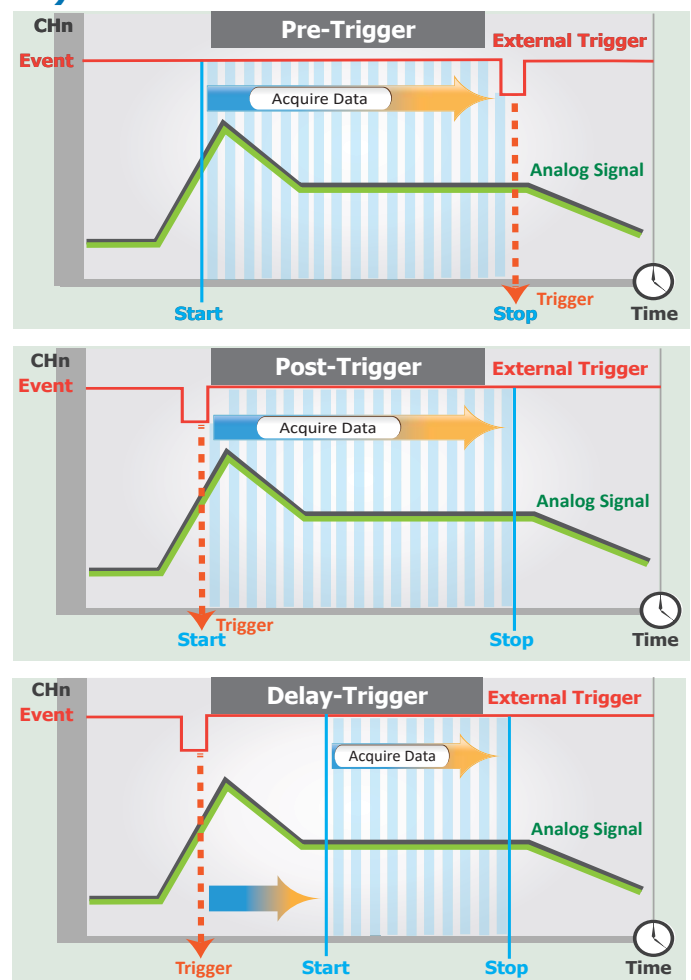

❖ Analog Threshold Trigger

The user can define a voltage range for an analog input channel to trigger A/D data acquisition. Acquisition of N data samples begins when the signal either exceeds the high threshold, drops below the low threshold, or enters/leaves the defined range. This flexible triggering mechanism optimizes data acquisition by focusing on key voltage transitions and reduces processing time by eliminating unnecessary data collection.

- 1. Above High:** Acquisition begins when the signal exceeds the high threshold.
- 2. Below Low:** Acquisition begins when the signal drops below the low threshold.

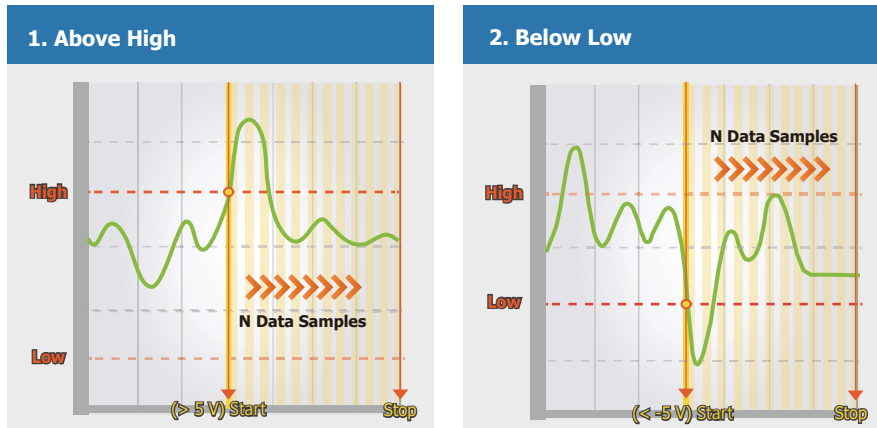

- 3. Leaving-Range:** Acquisition begins when the signal leaves the defined range.

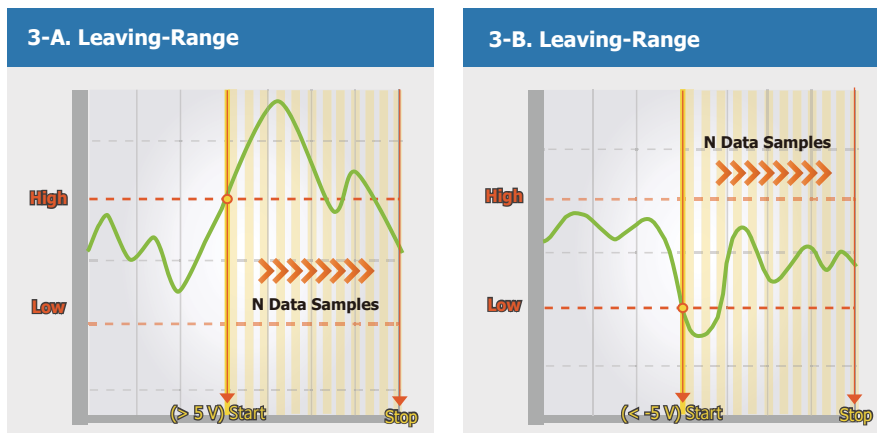

- 4. Entering-Range:** Acquisition begins when the signal enters the defined range.

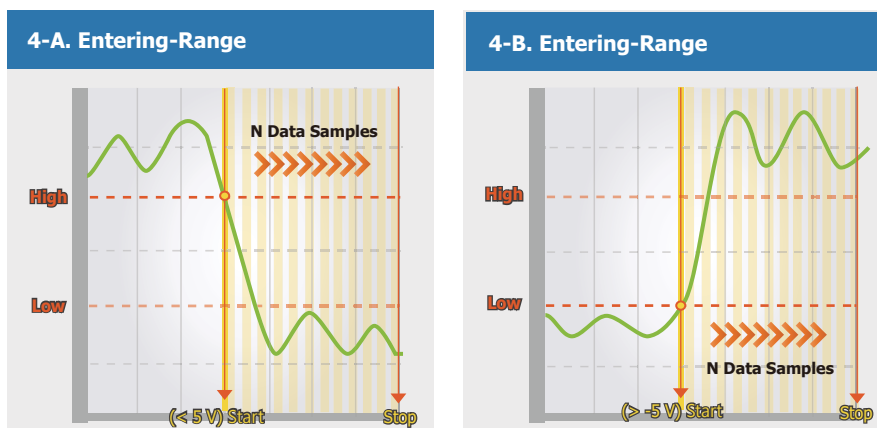

❖ A/D Sync Trigger Between Multiple Modules

A/D acquisition parameters are configured by commands from the Host PC and can be triggered by an external digital signal or synchronized with an external clock signal. Data acquisition of N samples begins upon detection of the trigger event, with the data buffered in the module's memory.

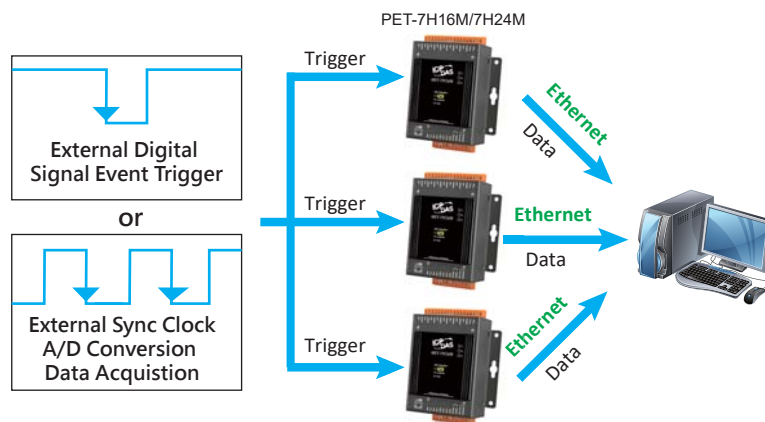

❖ Synchronous Data Acquisition for Multiple Input Types

The high-speed acquisition of the analog input/digital input/digital output read-back and counter input can also be read simultaneously, and these acquisition data can also be transferred to the Host PC with the Analog input sampling data. It is flexibly to define different input types into the Ethernet data frame of synchronous input data acquisition. In synchronous input data acquisition, the sampling rate can be 2 KHz Max.

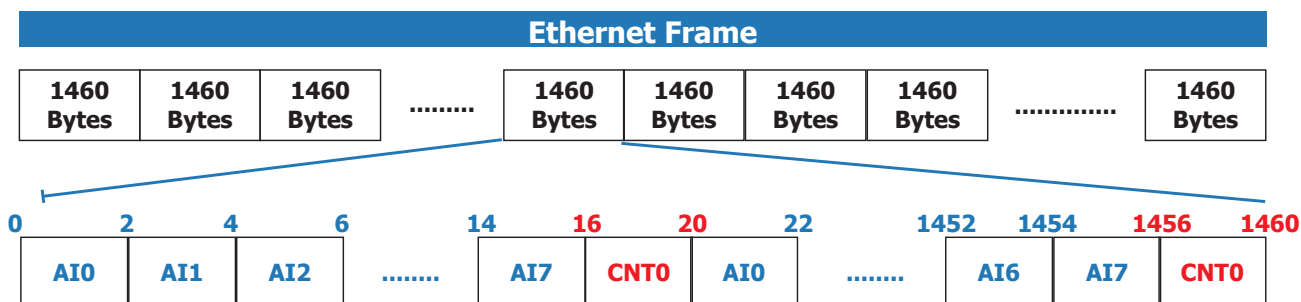
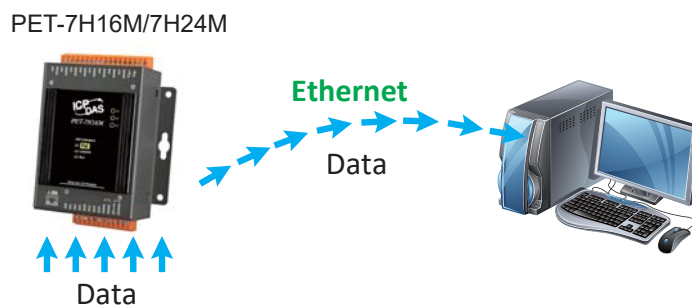

❖ PC Software Support

1. Windows

- Microsoft VC, C#, VB.NET SDK API and Demo
- Python and Demo
- NI LabVIEW Toolkit and Demo

2. Linux

- C/C++ library and Demo
- .NET library and Demo
- Python and Demo



Application:

❖ High Speed Vibration, Strain Gauge and Temperature Measurement Applications

The SG-3000 Series Signal Conditioning Module supports a wide variety of sensors, including current, voltage, thermocouples, resistance temperature detectors (RTDs), strain gauges, and vibration (IEPE accelerometers). It filters, isolates, amplifies, and converts input signals to voltage or current outputs suitable for measurement.

When used with the PET-7H16M/PET-7H24M High-Speed DAQ Module, users can monitor a range of signals and collect real-time data from multiple locations. This data is transmitted via Ethernet to a central management system, enabling efficient data collection and analysis for remote sensing applications.

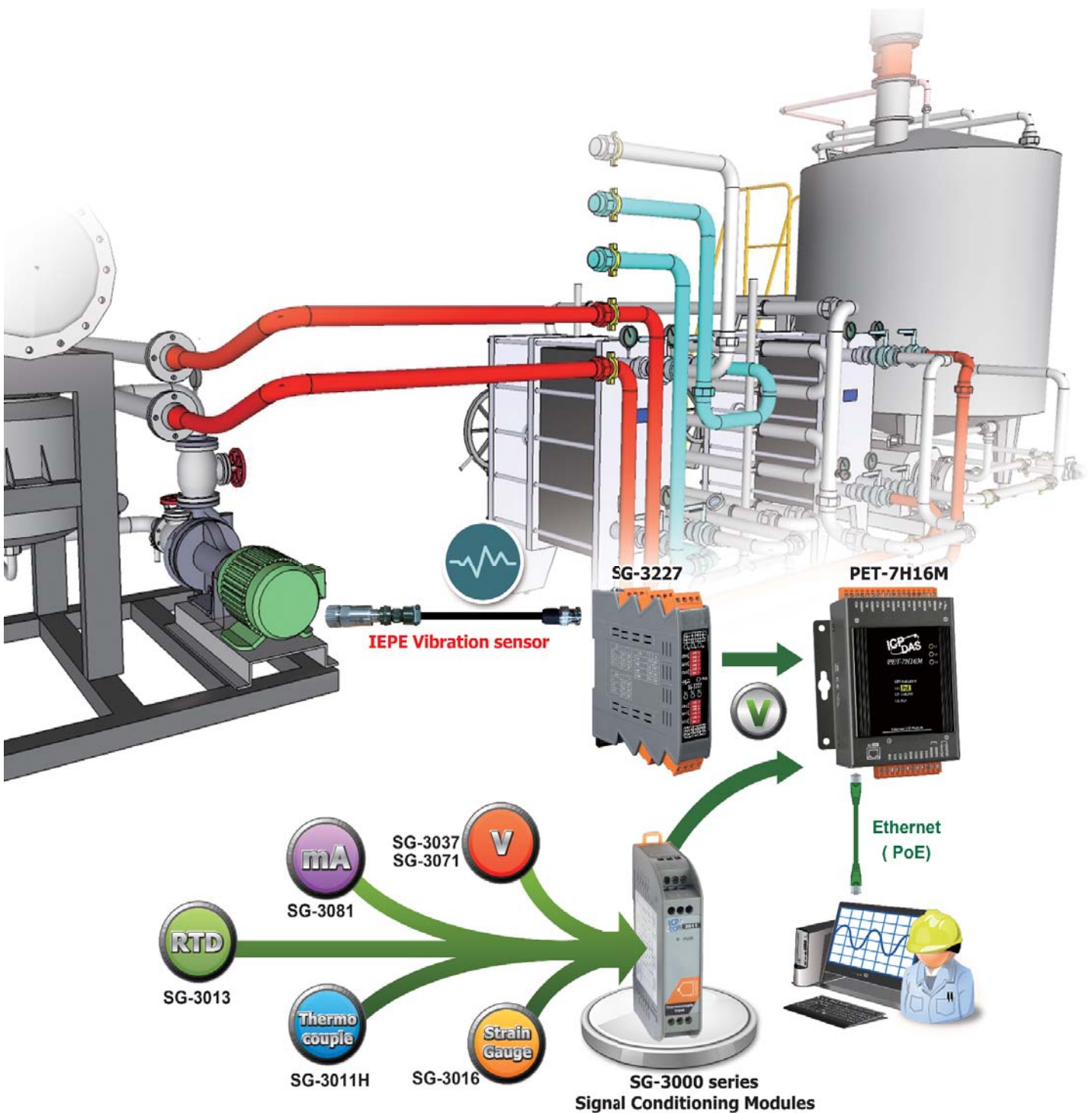

❖ Tool Wear Monitoring and Life Prediction

PET-7H16M with Raspberry Pi hardware is used to collect a large number of vibration signal data from the spindle and platform of the processing machine, with tool wear data, and use TensorFlow deep learning to analyze the tool wear prediction during the cutting process. The purpose is to estimate the tool wear in the future through random and short-term measurement of vibration signals. It is used to predict whether to replace unhealthy or unsafe cutting tool before the important material cutting process.

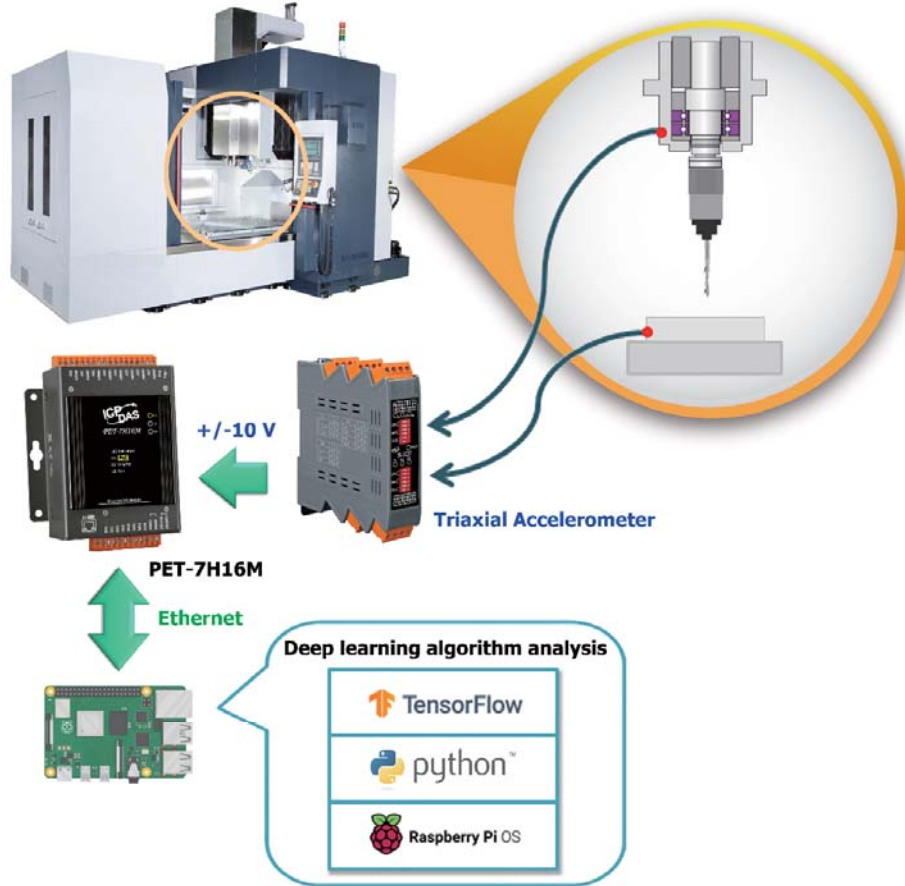

The Raspberry Pi open hardware enables diverse and customized applications in the Internet of Things (IoT) era. With Python, the most popular development tool for IoT, or Microsoft's cross-platform development tool .NET, it facilitates faster product and service deployment. ICP DAS provides libraries and sample programs for Python and .NET to remotely access the PET-7H16M and PET-7H24M modules. This integration allows users to quickly develop products and services using Raspberry Pi, supporting high-speed data acquisition and advanced data analysis for a wide range of IoT applications.

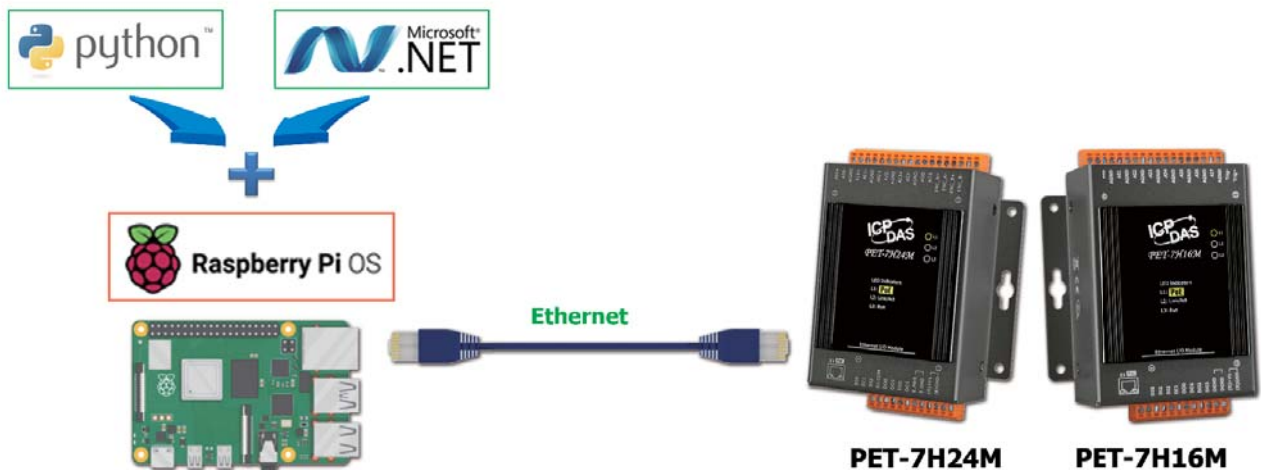

Signal Conditioning Modules for Vibration Sensors



Features:

- 3-channel voltage input & output
- Input voltage range: 0-24V
- Provides signal bandwidth: 50 kHz
- Provides 24V power supply for the accelerometer

SG-3037



Features:

- 2-channel IEPE input
- Individual channel configuration
- Excitation current support: 2 mA / 4 mA / 6 mA / 10 mA
- Signal amplification of x1, x10 and x100
- LED indicators for sensor open, short and normal

SG-3227

The SG-3037 and SG-3227 are vibration signal conditioning modules that convert accelerometer signals into analog voltage outputs suitable for measurement. The SG-3037 features three analog input and output channels, making it compatible with 3-axis accelerometers such as the iSN-703-F1-L015. The SG-3227, with two IEPE channels, supports IEPE accelerometers like the 1-axis iSN-701-F15-L030. These modules transmit the converted vibration signals to the PET-7H16M high-speed data acquisition module, which then sends the data via Ethernet to a data center for further processing and analysis.

Selection Guide:

Models	SG-3037	SG-3227
Analog Input for Accelerometer		
Channel	3	2
Wiring	5 wires	Differential
Signal	Voltage	IEPE
Type	0 ~ 24 V	0 ~ 28 V
Gain	-	x1, x10, x100
Bandwidth	50 KHz	x1, x10 Gain : 80 kHz ; x100 Gain : 50 kHz
Accuracy	±5% of FSR	
Excitation Current	-	2 mA, 4 mA, 6 mA, 10 mA
Excitation Voltage	24 V	-
Supported Accelerometer	iSN-703-F1-L015 (3-Axis) x 1	iSN-701-F15-L030 (1-Axis) x 2
Analog Output for Measurement		
Channel	3	2

IEPE Interface of SG-3227

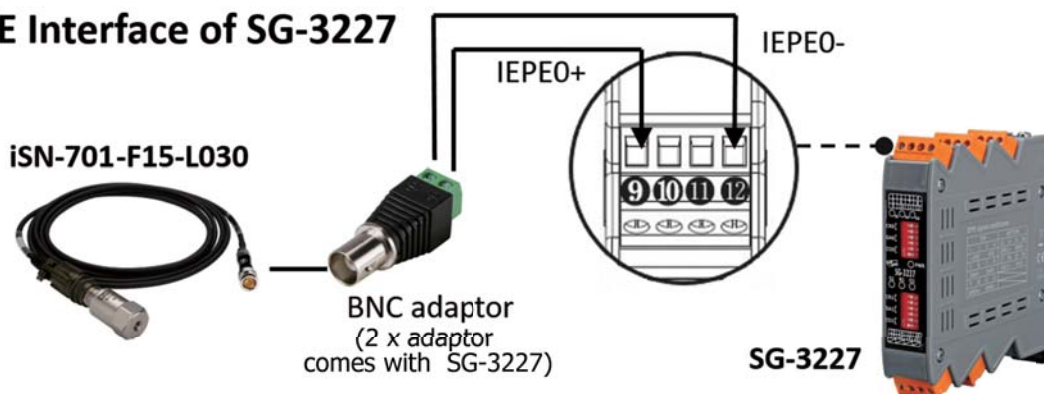

Accelerometer:



iSN-701-F15-L030
iSN-701-F15-L060
 (1-axis Accelerometer)



iSN-703-F1-L015
 (3-axis Accelerometer)



The iSN-701-F15-L030 and iSN-701-F15-L060 are homotaxial IEPE accelerometers designed for vibration measurement. The iSN-703-F1-L015 is a triaxial accelerometer that measures vibration in three orthogonal axes simultaneously. These highly sensitive sensors are specifically designed for precise vibration analysis applications.

Selection Guide:

Models	iSN-701-F15-L030 iSN-701-F15-L060	iSN-703-F1-L015
Type	1-Axis (IEPE)	3-Axis
Sensitivity	100 mV/g	400 mV/g per axis
Frequency Response	0.5 Hz ~ 15 kHz	10 Hz ~ 1 KHz
Measuring Range	±80 g	±18 g
Bias Voltage	10-14 VDC	10 ± 0.5 VDC
Power Requirement		
Voltage	18-30 VDC	22 - 26 VDC
Current	2~10 mA	3 mA
Mechanism		
Cable Length	iSN-701-F15-L030: 3 m iSN-701-F15-L060: 6 m	1.5 m
Magnetic Base	iSN-701-Mbase01 (optional)	iSN-703-Mbase01 (optional)

Dimensions:

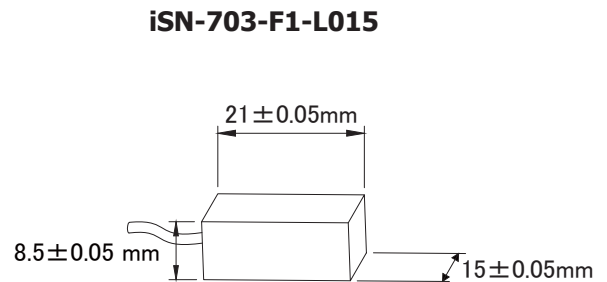
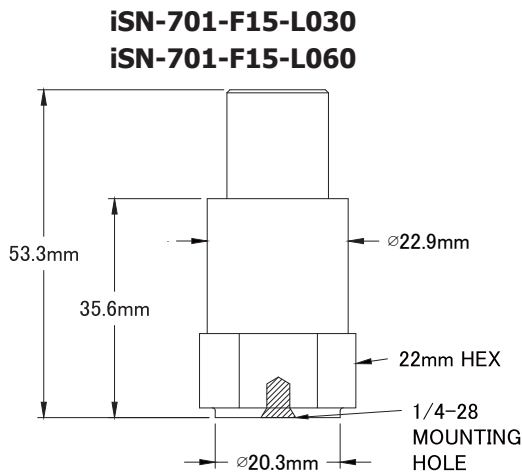

Applications:

● PET-7H16M connect SG-3037 with iSN-703-F1-L015



● PET-7H16M connect SG-3227 with iSN-701-F15-L030



● AR-200/AR-400 with iSN-701-F15-L030

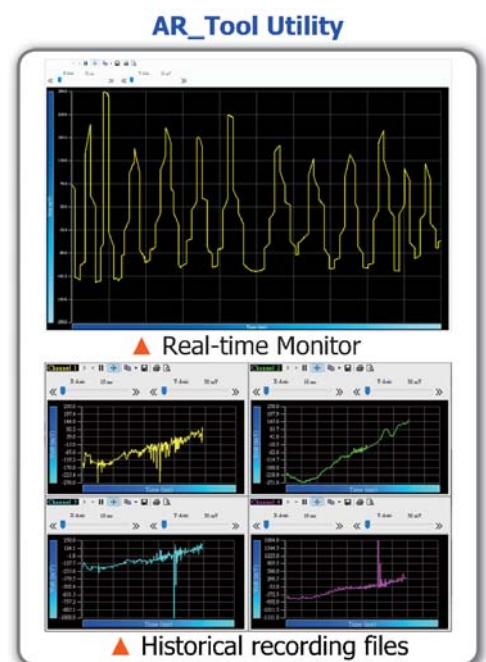
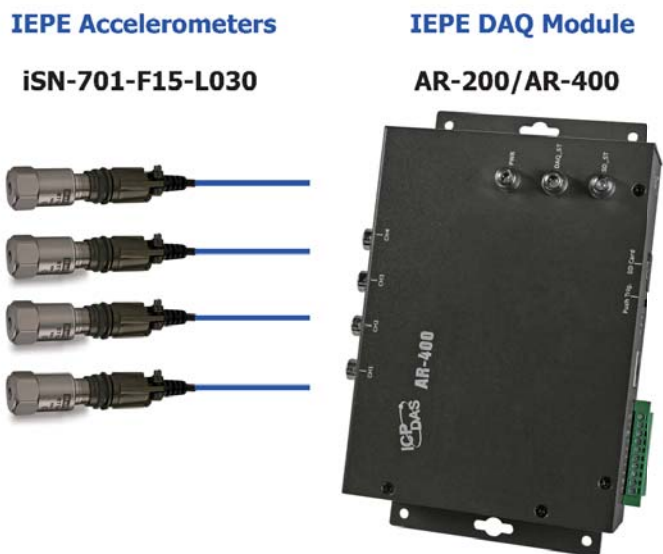

3.2 DAS-8000 High-Speed Ethernet DAQ System



Model	Ethernet	I/O Expansion	I-8KW Modules
DAS-8421	2 RJ45 Ports (Dual LAN), 10/100/1000M	4	Yes
DAS-8821		8	Yes

DAS-8421 / DAS-8821 are state-of-the-art, synchronous multi-channel data acquisition systems designed for high-speed, real-time data collection. Powered by a real-time multitasking operating system and high-performance hardware with Gigabit Ethernet communication, it ensures fast data processing and transfer. With a variety of high-speed I/O modules, the system meets the demands for precise and fast data acquisition and analysis. Its powerful data processing capabilities enable continuous data streaming to a PC, making it ideal for large-scale, high-speed acquisition. In addition, the system supports Modbus TCP slave communication, widely used in industrial automation, for easy and efficient data acquisition within the installed I-8KW and connected ET-2200 I/O modules.

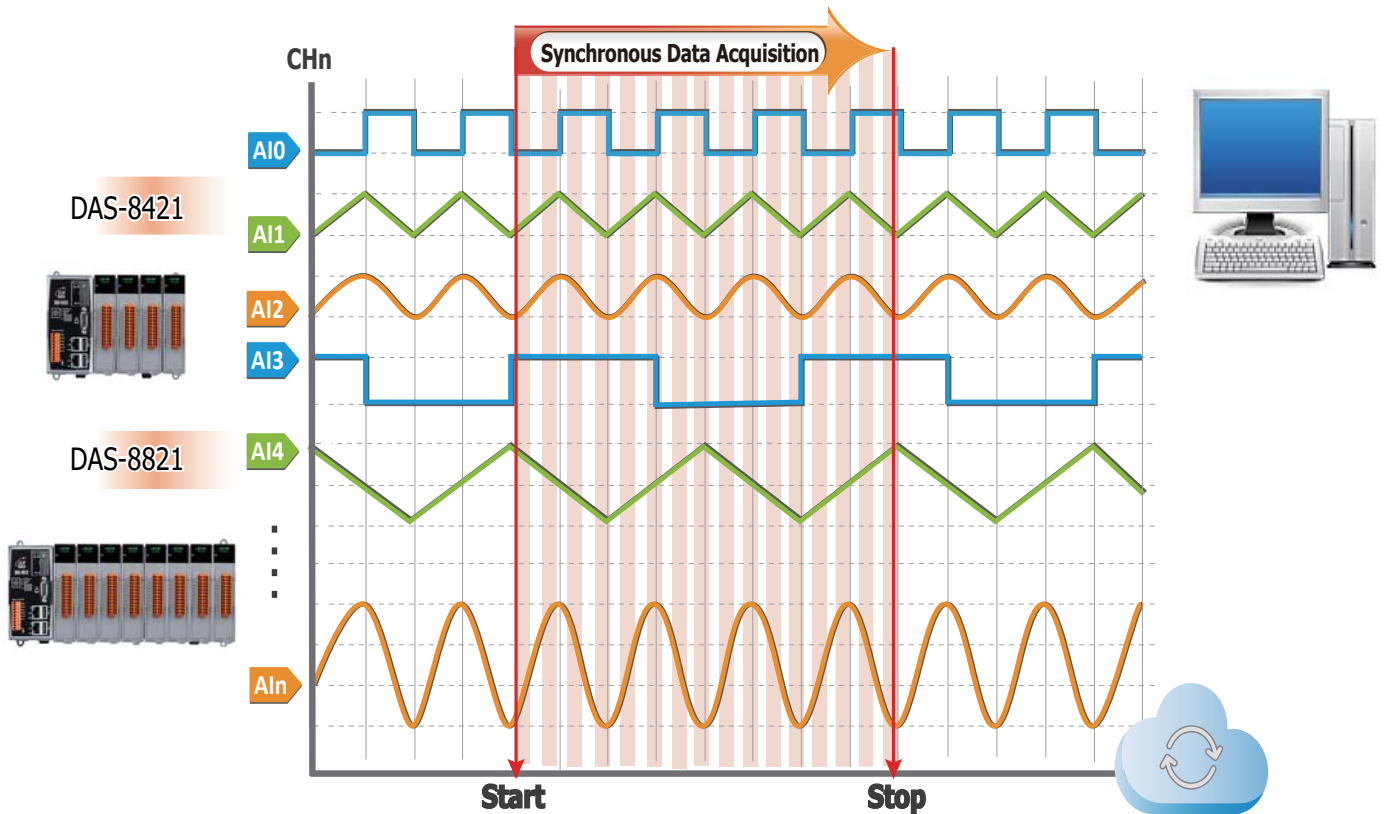

To support PC software development, a variety of SDKs and sample programs are available for Windows (VC, C#, VB.NET, .NET) and Linux (C/C++, .NET) for easy access to DAS-8000 systems. In addition, Python and .NET libraries with sample programs for the open hardware platform simplify the creation of high-speed data analysis applications that interact with these systems.

Features:

❖ Unified SDK and Demo Programs Simply Application Development

The DAS-8000 multi-channel high-speed data acquisition system and the PET-7H16M / PET-7H24M / PET-AR400 high-speed synchronous data acquisition modules share a common software development approach, utilizing the same SDK and related demo programs. This unified approach streamlines development, reduces integration time, and ensures consistency across different modules, offering significant ease of use and flexibility for developers. The SDK libraries make it easy for application programs to remotely start and stop DAS-8000 data acquisition, receive high-speed streaming data, and easily access data fields.

Ethernet multi-channel high-speed data acquisition module

DAS-8821/DAS-8421



Shared libraries



Ethernet high speed data acquisition module

PET-7H16M/PET-7H24M/PET-AR400



Ethernet multi-channel high-speed data acquisition system

DAS-8000 Series + ET-2000 Series

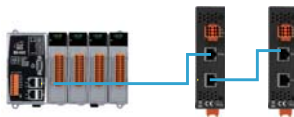

❖ TCP Streaming for High-Speed Analog Input (I-8014W / I-8014CW / I-8012W)

The DAS-8000 system provides efficient data acquisition for voltage, current, and temperature with high-speed sampling on all analog inputs, making it ideal for capturing fast-changing signals. It uses TCP streaming to continuously transfer data to the host PC with low latency and high performance. This continuous data streaming ensures reliable monitoring, which is critical for applications that require real-time data analysis and control.

The system also supports Modbus TCP slave communication, providing easy access and efficient data acquisition from the installed I-8KW and connected ET-2200 I/O modules. The widely used Modbus TCP protocol ensures compatibility and seamless integration with a broad range of HMI/SCADA systems.

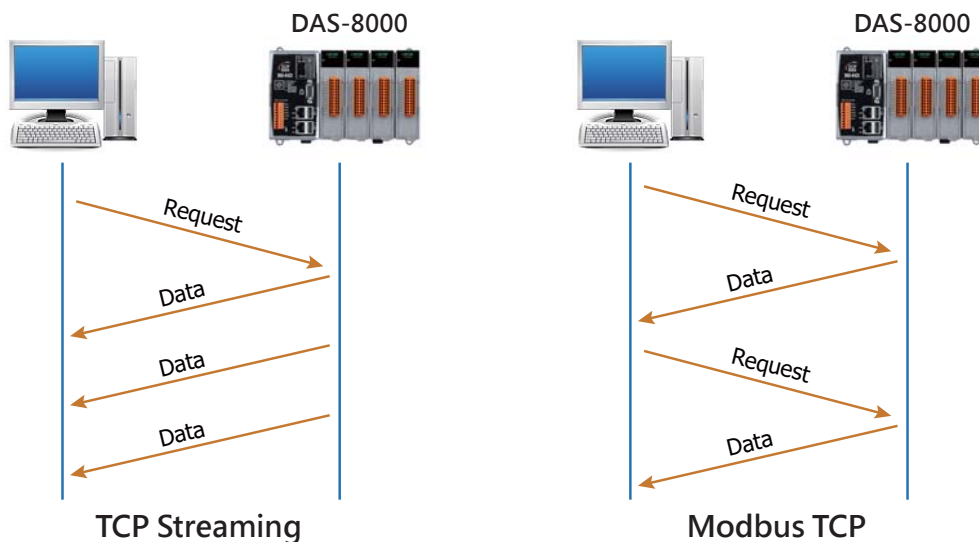

❖ Simultaneous and Accurate Multi-Channel Data Acquisition

The I-8012W module supports precise sampling frequencies and uses a sample-and-hold circuit to acquire all channels simultaneously. This approach eliminates timing discrepancies between inputs, improving the overall integrity and accuracy of the data. This method is especially beneficial for applications that require synchronized multi-channel signals, such as power monitoring, medical diagnostics, and industrial automation.

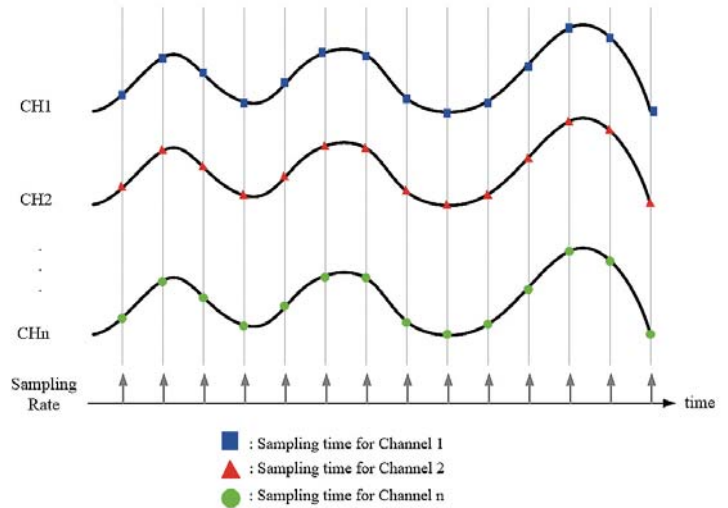

❖ Efficient Multi-Channel Data Acquisition with MagicScan

The I-8014W and I-8014CW modules feature the MagicScan mechanism, which automatically samples each input sequentially at precise frequencies and stores the ADC data directly into FIFO storage. FIFO ensures continuous and efficient data storage without overloading the system, while allowing the host to access the data without consuming valuable CPU processing time. This allows the CPU to focus on other critical tasks, optimizing overall system performance.

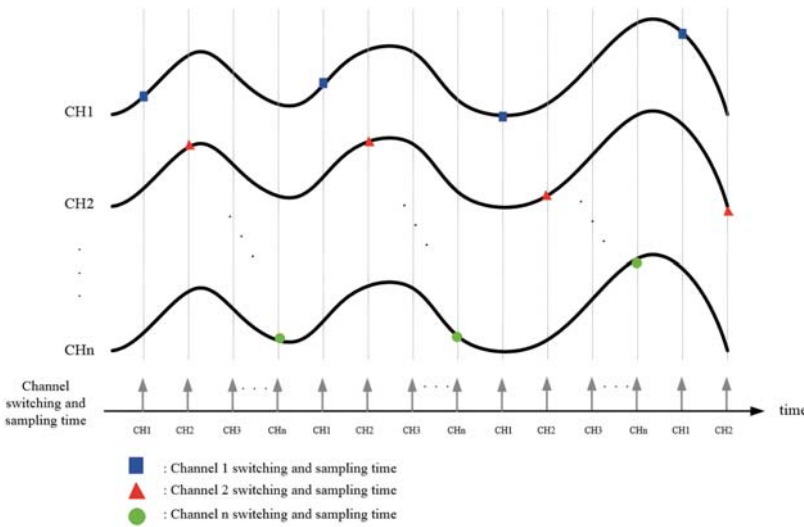

❖ Virtual Simultaneous Data Acquisition with MagicScan

The I-8014W and I-8014CW modules support advanced virtual simultaneous data acquisition based on MagicScan. The system starts the sampling process with a sampling clock and then samples all configured channels sequentially in an exceptionally short time. This approach automatically switches between channels, ensuring stable and accurate signal acquisition. The fixed, minimal switching time makes it ideal for applications where relative timing between channels is less critical or where small timing differences can be tolerated.

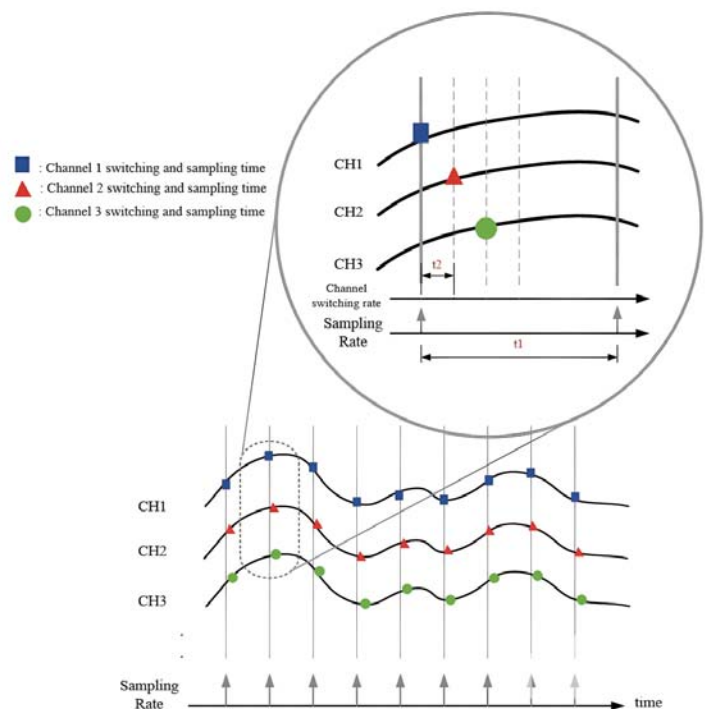

❖ Synchronous Data Acquisition across Multiple Modules

The I-8012W module supports synchronous data acquisition across multiple modules, ensuring accurate and coordinated data acquisition. Acquisition is triggered by an external clock signal sent to each Trig.I pin of the I-8012W modules, providing consistent and reliable data synchronization across all modules. In addition, the first I-8012W module has a clock output (Trig.O) that can be used as a trigger source. This flexibility allows synchronization to be triggered by either an external clock or the internal clock, depending on the specific requirements of your application. The ability to synchronize multiple modules simplifies system expansion, making it ideal for larger data acquisition tasks without sacrificing performance.

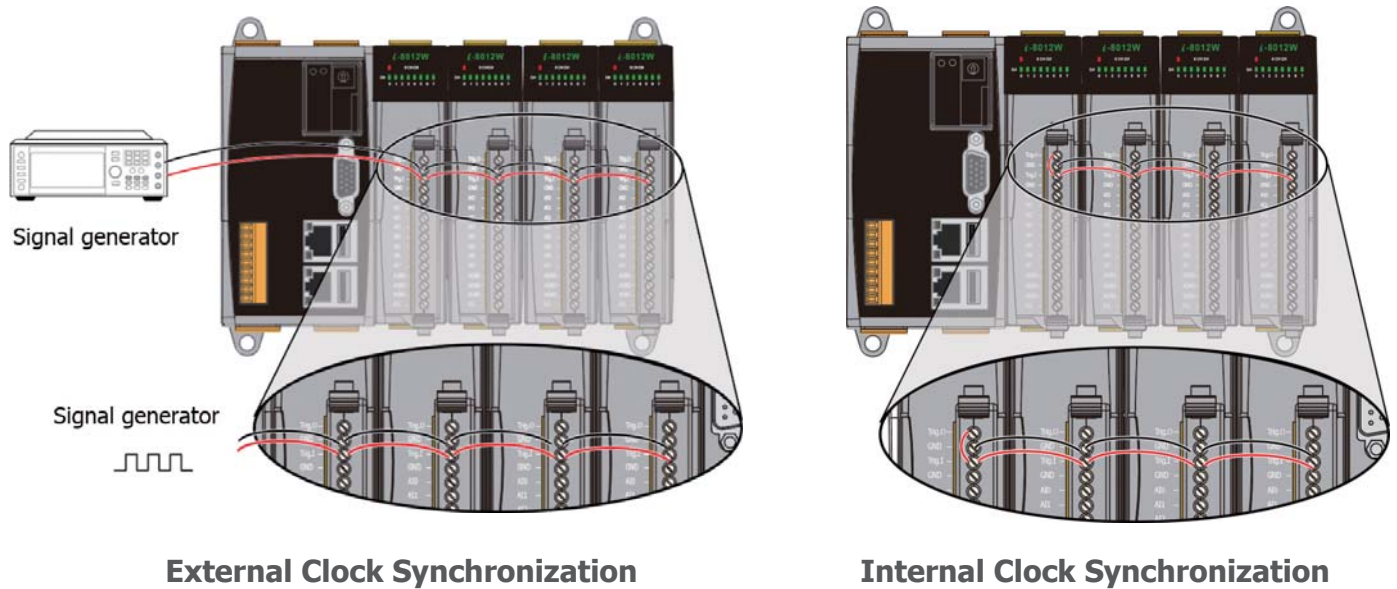

❖ Mixed Data Acquisition with Flexible I/O Expansion

The DAS-8000 system supports flexible, mixed data acquisition, allowing various I-8KW I/O modules to be inserted into expansion slots based on specific requirements. Up to 8 ET-2200 I/O modules can be connected through LAN2 to further expand the number of I/O points, offering scalability to meet diverse application needs. Upon powering on, the system automatically initializes the inserted and connected I/O modules, sequentially configuring their Modbus TCP memory addresses. This automatic initialization reduces setup time and ensures seamless operation right from startup. Users can easily access all inserted and connected I/O modules via a single Modbus TCP connection, simplifying integration into a wide range of applications. The scan rate between the PC and DAS-8000 can be adjusted from 1 Hz to 250 Hz, providing flexible data acquisition speeds to meet various requirements.

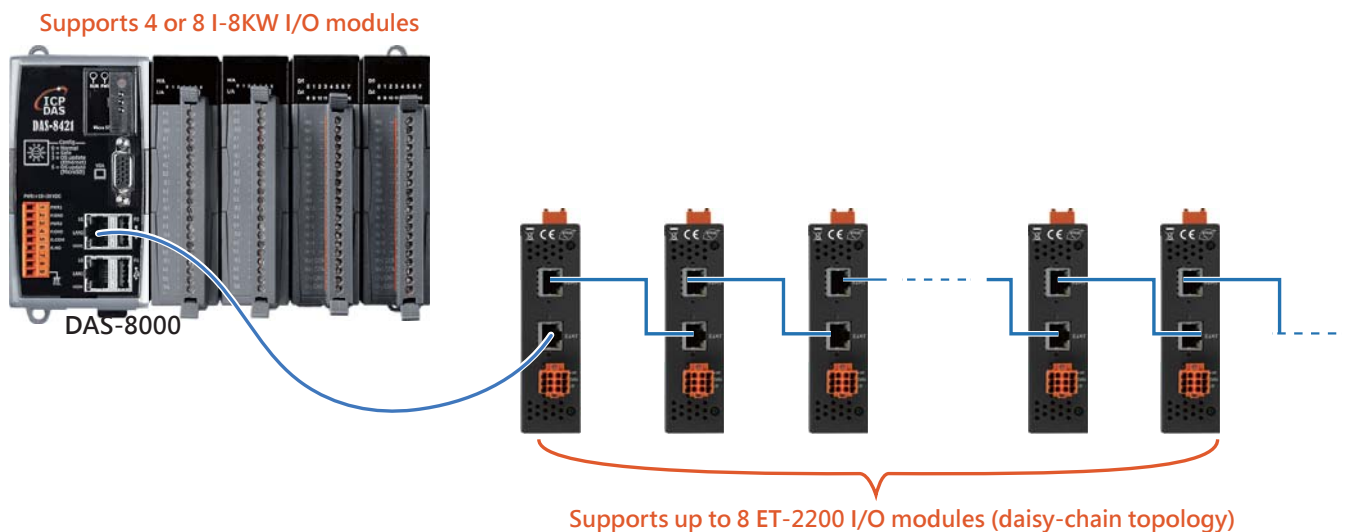

Max. Sampling Rates (Continuous Acquisition) of Different Analog Input Modules and Channels

Analog Input Modules	Analog Input channels	Max. Sampling Rate
ET-2217H	1 ~ 8	8 KHz / 1 channel
PET-7H16M	1 ~ 8	30 KHz / 8 channels 200 KHz / 1 channel
DAS-8000 + I-8012W	8 ~ 128	15 KHz / 64 channels
DAS-8000 + I-8014W / I-8014CW	8 ~ 128	6 KHz / 128 channels

❖ Dual LAN for Optimized Network Separation

The DAS-8000 system provides two Ethernet ports for dual LAN applications, allowing ET-2200 I/O modules connected to LAN2 to remain isolated from the primary LAN1 network. This design prevents direct access to modules on LAN2 from computers on LAN1. By isolating the two networks during I/O operations, dual LAN increases both network security and performance. It also improves system reliability and provides greater flexibility in network design.

❖ Digital Event Trigger Modes

A/D data acquisition uses three trigger modes, each activated by the falling edge of a external trigger signal. The maximum sampling rate of each channel is 200 kHz, and N data samples are acquired and buffered in memory.

1. Pre-Trigger

Data acquisition proceeds until the trigger signal is detected. Once the trigger is received, acquisition stops and the stored data is transferred to the host PC.

2. Post-Trigger

Data acquisition starts immediately upon receiving the trigger signal. Acquisition stops once the specified number of samples has been collected, and the data is transferred to the host PC.

3. Delay-Trigger

Data acquisition begins after a programmed delay period following the trigger signal. Acquisition stops once the specified number of samples has been collected, and the data is transferred to the host PC.

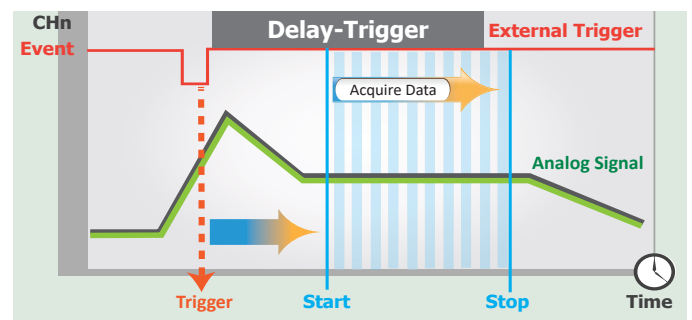
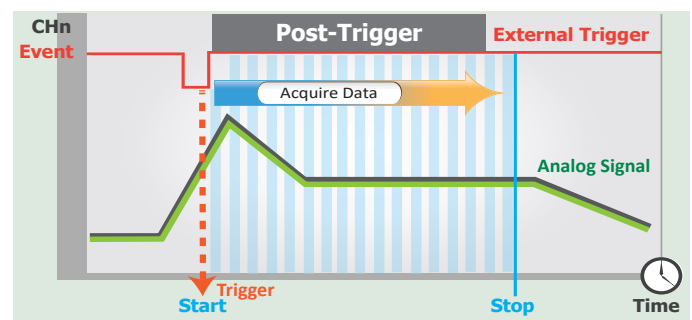
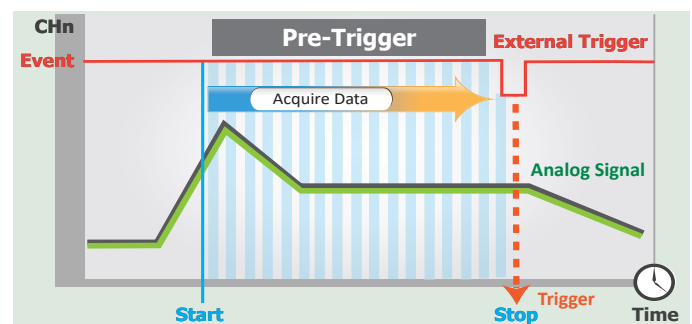

❖ Analog Threshold Trigger

The user can define a voltage range for an analog input channel to trigger A/D data acquisition. Acquisition of N data samples begins when the signal either exceeds the high threshold, drops below the low threshold, or enters/leaves the defined range. This flexible triggering mechanism optimizes data acquisition by focusing on key voltage transitions and reduces processing time by eliminating unnecessary data collection.

1. **Above High:** Acquisition begins when the signal exceeds the high threshold.
2. **Below Low:** Acquisition begins when the signal drops below the low threshold.

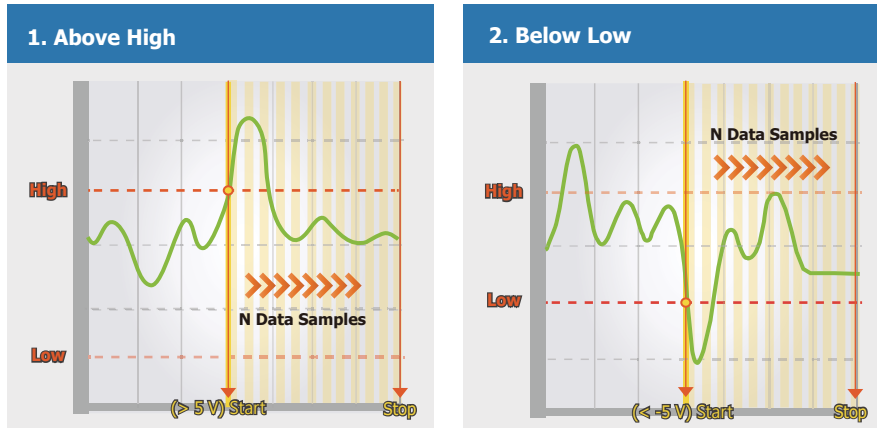

3. **Leaving-Range:** Acquisition begins when the signal leaves the defined range.

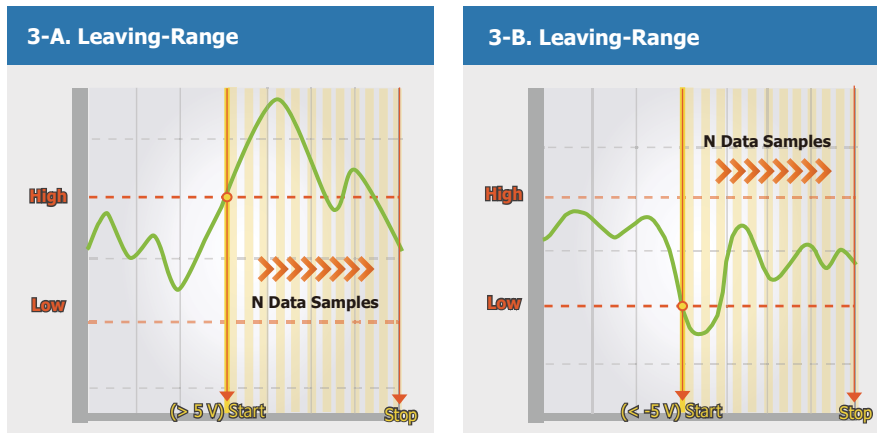

4. **Entering-Range:** Acquisition begins when the signal enters the defined range.

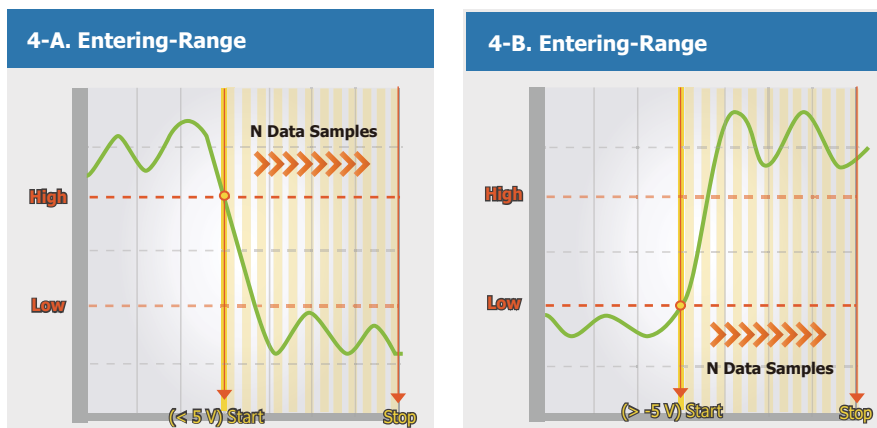

More Features

- Up to 8 I/O Expansion Slots for Flexible Configurations
- Various I/O Module Options for Diverse Applications
- Dual Watchdog with Power-On and Safe Value
- No Custom Program Required in DAS-8000 System
- Fanless Cooling Design for Enhanced Durability
- Wide Power Input Range (+10 to +30 VDC)
- Wide Operating Temperature Range (-25°C to +75°C)
- Daisy-Chain Ethernet Cabling (ET-2200) for Total Cost Reduction
- Rotary-switch with IP configuration (ET-2200) for Easy Maintenance

Semiconductor Equipment Applications

Active Temperature Control (ATC) systems are critical in today's semiconductor IC test equipment. They provide precise and stable temperature control to ensure optimal device performance, improve test accuracy, reduce cycle time, and increase energy efficiency. The DAS-8000 system supports high-speed, synchronous, multi-channel analog data acquisition for accurate and reliable temperature measurement. This makes the DAS-8000 system ideal for ATC applications or any situation where rapid temperature changes must be monitored.

System Composition: DAS-8421 x 1 , i-8018W x 4 , ET-2228 x 1 , ET-2217 x 2

- DAS-8421: Rapidly collects data from installed I-8018W modules and connected ET-2200 modules via LAN2. It uses TCP streaming to quickly transmit data to a PC for analysis.
- I-8018W: An 8-channel high-speed thermocouple input module, it provides real-time temperature data from various positions of the machine to the temperature control system, allowing adjustments to heating and cooling elements as needed to maintain the required temperature curve.
- ET-2228: An 8-channel analog output module that controls the flow switches of the ATC system.
- ET-2217: An 8-channel analog input module that measures flow or voltage values of the test objects.

Advantages

- 32-channel thermocouple temperature measurement, each channel providing a 100 Hz sampling rate, with each channel independently configurable for input type.
- Flexible centralized & distributed deployment of modules based on the machine's functional characteristics and space constraints.
- DAS-8000 actively gathers data from local and remote modules, enabling PC software to retrieve all data via a single connection, eliminating the need for multiple remote module access.









Ethernet I/O Products

- 4.1 (P)ET-7x00 Ethernet Modbus TCP I/O Modules - - - - - P 65
- 4.2 (P)ET-2200 Slim-Type Modbus TCP I/O Modules - - - - P 72
- 4.3 tET/tPET Tiny-Size Modbus TCP I/O Modules - - - - - P 77
- 4.4 MQ-7200M MQTT I/O Modules - - - - - P 81

Our Ethernet remote I/O modules support Modbus TCP/UDP, MQTT, and SNMP protocols, and provide web HMI, Web server, OPC server, security mechanism..etc. According to different application, we have developed various Ethernet I/O units and modules, such as compact size ET-87Pn-MTCP/ET-8KPn-MTCP units, palm-size (P)ET-7000/(P)ET-7200 series, tiny-size tET/tPET and slim-type (P)ET-2200 series. The module has diversified I/O interface, such as overvoltage-protection analog input, relay output, digital input/output, counter, timer.

Modbus Product Lines Comparison Table

Product Line	ETS-7200	ET-7200 PET-7200	ET-7000 PET-7000	ET-2200 PET-2200	tET tPET
Pictures					
Page	P.27	P.65	P.65	P.72	P.77
Ethernet	2-Port Switch, 10/100 M (Daisy-Chain)		1-Port 10/100 M	2-Port Switch, 10/100 M (Daisy-Chain)	1-Port 10/100 M
PoE	-	PET-7200 Series	PET-7000 Series	PET-2200 Series	tPET Series
IPv4/IPv6	IPv4/IPv6	IPv4	IPv4	IPv4/IPv6	
Protocol	Modbus TCP/UDP/ TLS, MQTT (TLS option), SNMP V2c/V3	Modbus TCP/UDP	Modbus TCP/UDP	Modbus TCP/UDP, MQTT, SNMP V2c (Note 1)	
Security	ID/Password, IP Filter, IEEE 802.1X Auth, SSL/TLS Encryption	ID/Password, IP Filter		Password, IP Filter	
Additional Functions	Rule Logic Engine, 802.1Q/802.1p Priority Tagging	Over 100 models available.		PWM Outputs: 100 Hz max., Frequency Measurement, High-Speed Analog Inputs, DI Invert, Pulse Output.	
Web HMI	User-Defined			Basic	
Multi-client	Yes (32)	Yes (12)		Yes (32)	
DI Counter (32-bit)	100 Hz max.		100 or 500 Hz max.	2.5 kHz max.	
DIO LEDs	Yes		-	Yes	-
Power Input	+12 ~ +48 VDC, 4 pins (2-pair)		+10 ~ +30 VDC, 2 pins (1-pair) (Note 2)	+12 ~ +48 VDC, 2 pins (1-pair)	
Form Factor	Palm Size			Slim Type	Tiny Size
DIN-Rail Space	7.6 cm		7.2 cm	3.3 cm	5.2 cm

Note 1: Most of the new tET/ET-2200 models support the SNMP protocol.

Note 2: Some ET-2200 models support +10 ~ +48 VDC power input.

Note 3: Common features include latched DI, pair-connection (push/pull), and dual watchdog (module/host).

4.1 (P)ET-7x00 Ethernet Modbus TCP I/O Modules



The ET-7000/ET-7200 is a web-based Ethernet I/O module that allows users to configure, monitor, and control I/O via a standard web browser. Remote control is as simple as browsing the Internet. No programming or HTML skills are required to create dynamic, interactive Web HMIs for I/O monitoring and control, making it an efficient and user-friendly solution for engineers.

The module also supports the Modbus TCP / UDP protocols, ensuring seamless integration with SCADA software. Additionally, it features Power over Ethernet (PoE), which combines data transmission and power delivery into a single Ethernet cable, simplifying installation.

Features:

❖ Power over Ethernet (PoE) for Easy Wiring

The PET-7000/PET-7200 modules support IEEE 802.3af-compliant PoE switches, enabling both data communication and power delivery through a single Ethernet cable. This eliminates the need for additional wiring and an external power supply, streamlining installation.



❖ Ethernet Daisy-Chain Cabling for Cost Savings

The (P)ET-7200 modules have a built-in two-port Ethernet switch, enabling daisy-chain topology for simplified cabling. This eliminates the need for additional switches, reducing overall costs.

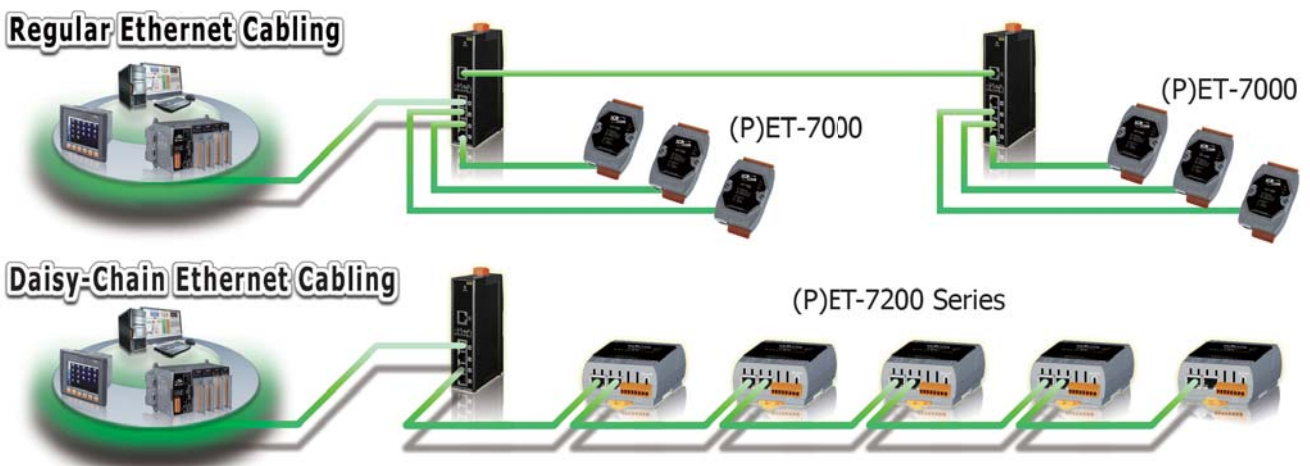

❖ LAN Bypass for Continuous Connectivity

The LAN Bypass feature is automatically activated to maintain network traffic when the (P)ET-7200 module loses power.



❖ Security with Access Control

An account and password are required to access the web server. The IP address filter allows administrators to permit or deny connections from specific IP addresses, enhancing overall security.

❖ Support for both Modbus TCP and Modbus UDP Protocols

The Modbus TCP, Modbus UDP slave function on the Ethernet port can be used to provide data to remote SCADA software.

❖ Integrated Multi-Function I/O

A single module combines multiple I/O types with various channels, maximizing cost-effective utilization and enhancing I/O operation performance.

❖ Dual Watchdog for Increased System Reliability

The Module Watchdog (hardware circuit) ensures reliable operation by resetting the CPU if it freezes due to noise or other issues, restoring outputs to predefined Power-on Values. The Communication Watchdog activates if no commands are received from the host within a programmable timeout, setting outputs to predefined Safe Values. This dual watchdog mechanism enhances system reliability, protects connected devices, and ensures operator safety.

❖ Highly Reliable Under Harsh Environment

- Wide Operating Temperature Range: -25 ~ +75°C
- Storage Temperature: -30 ~ +80°C
- Humidity 10 ~ 90% RH (Non-condensing)



❖ Power-on Value and Safe Value

Power-on Value: Applied to outputs during power-up, Module Watchdog reset, or reset commands.

Safe Value: Applied to outputs upon Communication Watchdog timeout, if enabled.

❖ LED Indicators for Easy Diagnostics

(P)ET-7200 modules feature DIO status LEDs to provide clear, real-time operating status feedback and simplify I/O control diagnostics.

❖ Reset Button for Easy Restoration

The reset button of the (P)ET-7200 is used to restore all settings to factory defaults. It is especially useful if you forget the ID or password for the web server or the IP address for accessing the module.

❖ Two Pairs (4 Pins) of Power Input

(P)ET-7000 modules have one pair (2 pins) of power input. (P)ET-7200 modules are expanded to two pairs (4 pins) for more flexibility in power wiring.

❖ I/O Pair Connection

This function creates an AI/DI-to-AO/DO link over Ethernet. Once configured, the module continuously polls remote AI/DI device status via the Modbus TCP protocol and automatically updates local AO/DO channels.

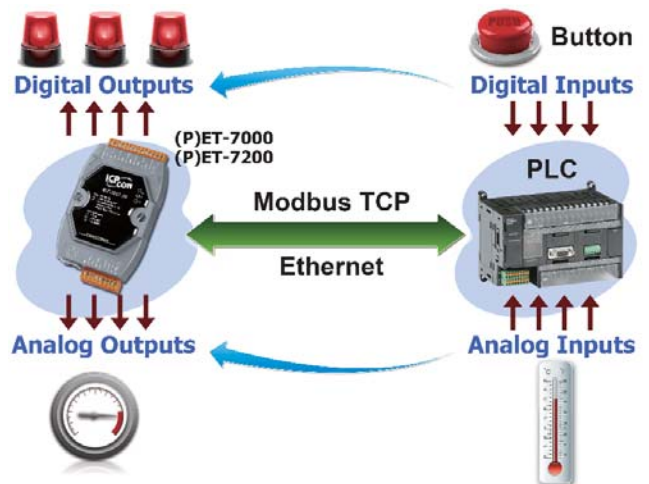

❖ Customizable Web HMI

The Web HMI function allows the users to create dynamic and attractive web pages to monitor and control the I/O points. Users can upload specific I/O layout pictures (bmp, jpg, gif format) and define a description for each I/O point. No HTML or Java skills are needed to create the web pages.

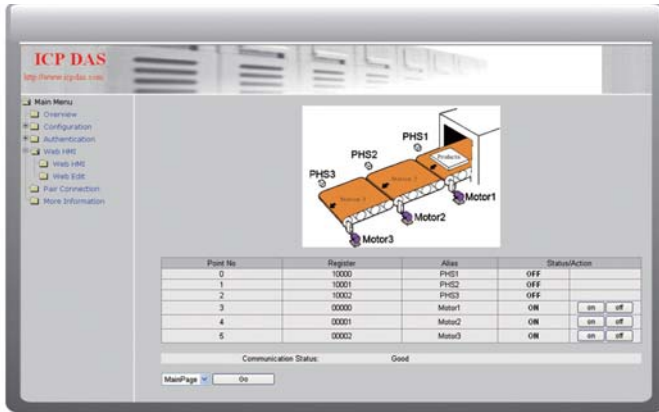

❖ Built-in Web Server

Each I/O module has a built-in web server that allows the users to easily configure, monitor and control the module from a remote location using a regular web browser.



Appearance:

(P)ET-7000 Series

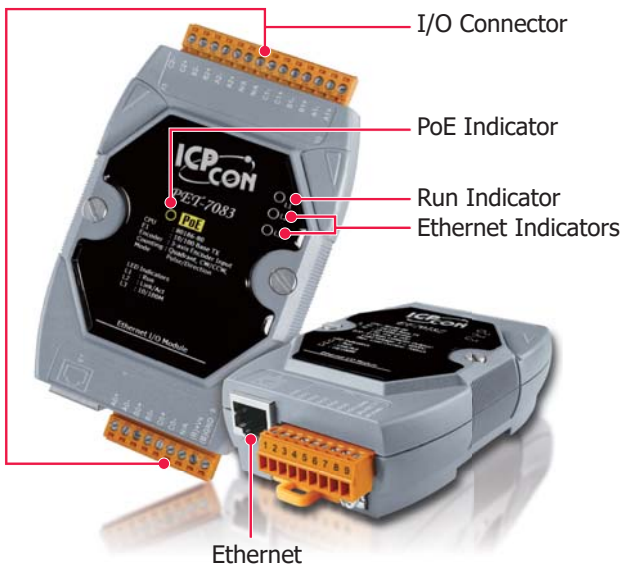

(P)ET-7200 Series

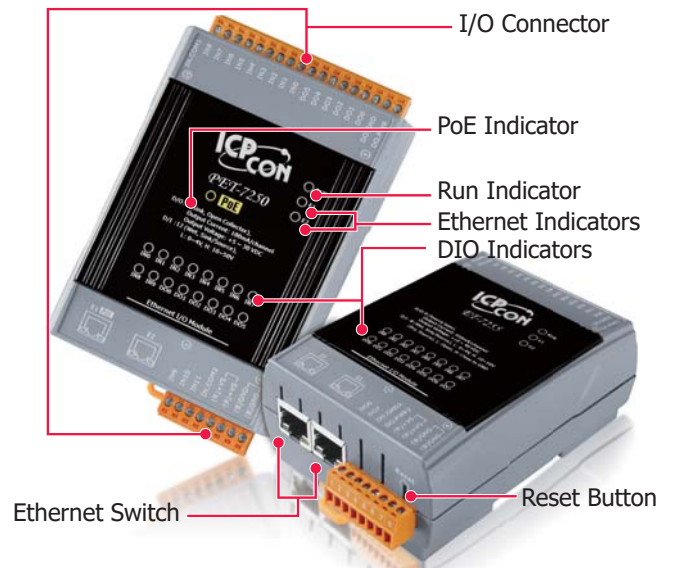

Dimensions (Units: mm):

(P)ET-7000 Series

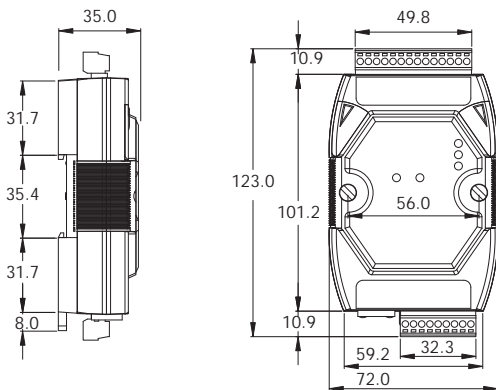

Left View

Front View

(P)ET-7200 Series

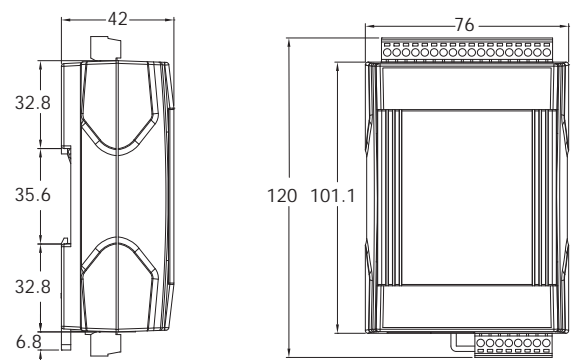

Left View

Front View

Software Support:

1. OPC Data Access (DA) Server

Supporting the OPC protocol, the NAPOPC_ST DA Server enables seamless communication between ICP DAS products and various SCADA, HMI, and database systems. It is available in free and licensed versions, with the licensed option allowing third-party device integration.

This server streamlines integration between diverse software and hardware components, enhancing system interoperability and ensuring efficient data exchange. Designed for industrial and manufacturing environments, it ensures reliable data flow, simplifies configuration and maintenance, and optimizes system efficiency and productivity.

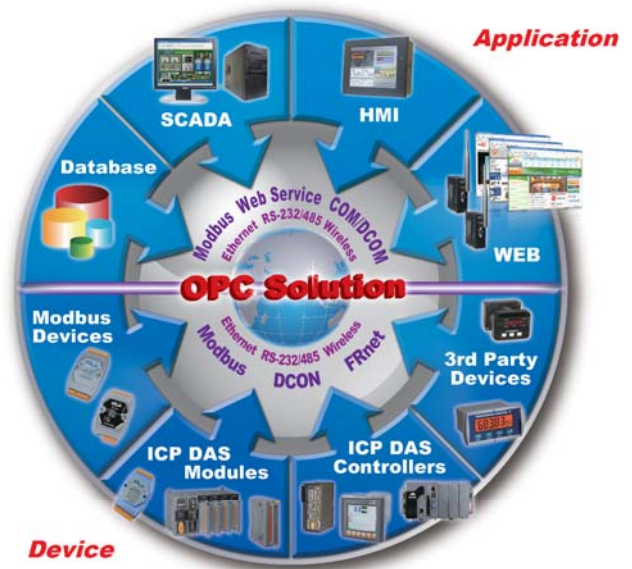

2. EZ Data Logger for Windows XP/7/10/11

EZ Data Logger is an efficient and compact data logging solution that supports Modbus TCP/RTU/ASCII and DCON protocols, providing access to a wide range of slave I/O devices. It is ideal for small-scale data logging and remote I/O control applications. With its user-friendly interface, users can easily set up a small SCADA system without any programming skills.



3. eLogger – User-Friendly HMI and Data Logging

eLogger is an easy-to-use HMI, Web HMI, and data logging software for Windows 10/11 PCs and ICPDAS PACs, enabling simple I/O monitoring and system control. It supports Modbus TCP/RTU protocols, allowing seamless integration with various slave I/O devices. eLogger is free for up to 30 tags on the PC version, helping to reduce costs and time to market.

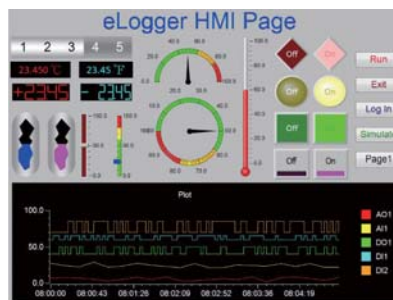

4. Modbus Software Development Toolkits

Plenty of library functions and demo programs are provided to let user develop programs easily under Windows, Linux and MiniOS7 operating systems.

OS	Development Language	SDK
MiniOS7	TC, BC	MBT7_xxx.lib, MBT8_xxx.lib and Demos
WinCE 5.0/6.0	VS .NET 2005/2008	nModbusCE.dll and Demos
WES 2009, Windows XP/Vista/7	VS .NET 2005/2008	nModbus.dll and Demos
	LabVIEW	Demos
Linux	C	Libraries and Demos

Selection Guide:

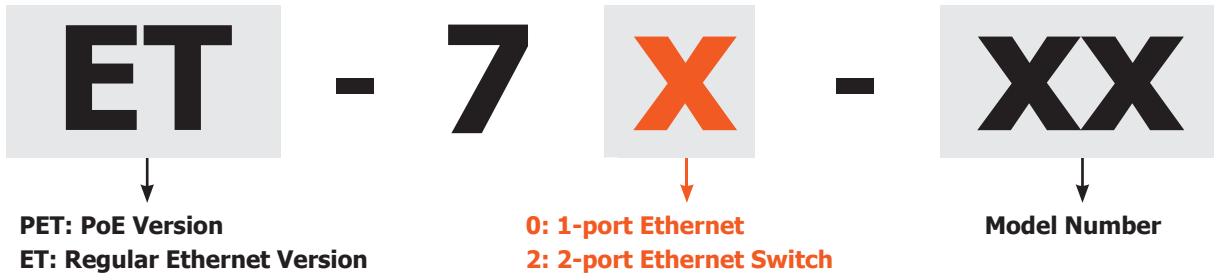

Model Name		AI			DO		
		Channel	Range	Sensor Type	Channel	Type	Sink/Source
ET-7005 PET-7005	-	8	-	Thermistor	4	Open Collector	Sink
ET-7015 PET-7015	ET-7215 PET-7215	7	-	RTD: Pt100, Pt1000, Ni120, Cu100, Cu1000	-	-	-
ET-7017 PET-7017	ET-7217 PET-7217	8	±150 mV, ±500 mV, ±1 V, ±5 V, ±10 V, ±20 mA, 0 ~ 20 mA, 4 ~ 20 mA	-	4	Open Collector	Sink
ET-7017-10 PET-7017-10	ET-7217-10 PET-7217-10	10/20			-	-	-
-	ET-7217-A5 PET-7217-A5	8	±50 V, ±150 V	-	4	Open Collector	Sink
-	ET-7217RMS PET-7217RMS	8	0 ~ +150 mVrms 0 ~ +500 mVrms, 0 ~ +1 Vrms, 0 ~ +5 Vrms 0 ~ +10 Vrms,				
ET-7018Z/S PET-7018Z/S	ET-7218Z/S PET-7218Z/S	10	±15 mV, ±50 mV, ±100 mV, ±500 mV, ±1 V, ±2.5 V ±20 mA, 0 ~ 20 mA, 4 ~ 20 mA	Thermocouple: J, K, T, E, R, S, B, N, C, L, M, and LDIN43710	6/3 <i>(Note 2)</i>	Open Collector	Sink
ET-7019Z PET-7019Z	ET-7219Z PET-7219Z	10			±15 mV, ±50 mV, ±100 mV, ±150 mV, ±500 mV, ±1 V, ±5 V, ±10 V ±20 mA, 0 ~ 20 mA, 4 ~ 20 mA		

Note 1: We recommend to choose ET-7018Z/PET-7018Z and ET-7019Z/PET-7019Z for extremely accurate thermocouple measurement.
Note 2: 6 DO channels for ET-7018Z, PET-7018Z, ET-7019Z and PET-7019Z.
 3 DO channels for ET-7218Z, PET-7218Z, ET-7219Z and PET-7219Z.

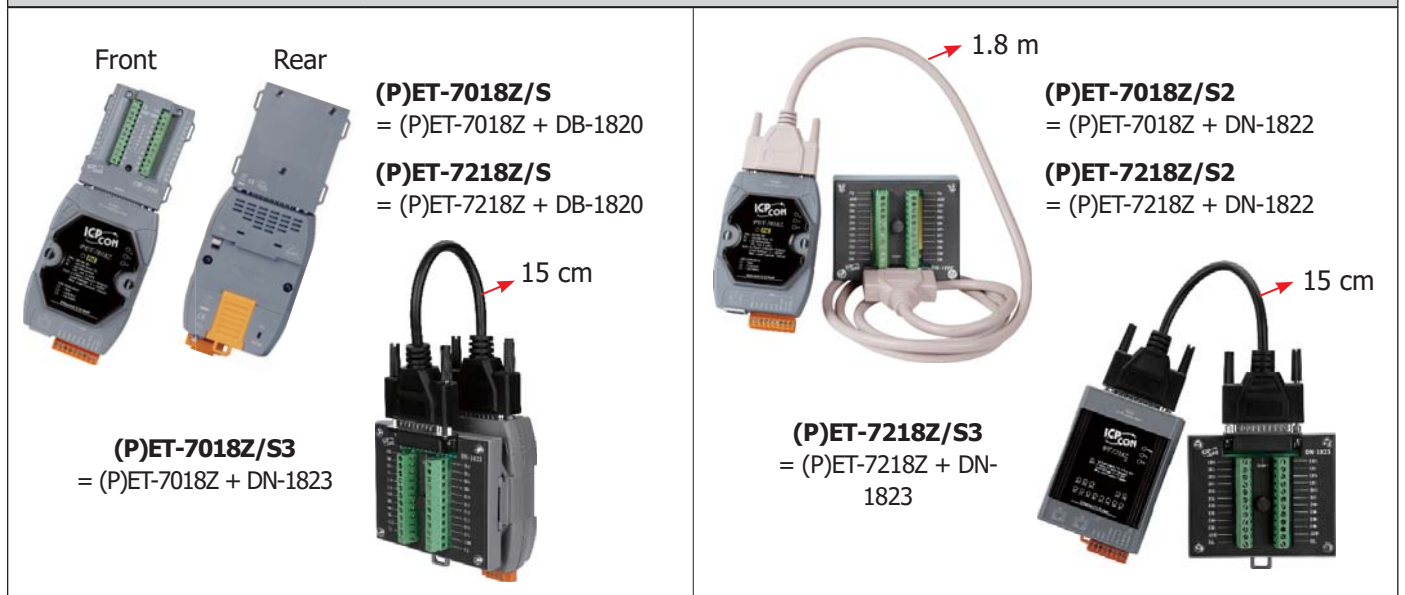

 Multi-function I/O

Model Name		AI			AO		DI/Counter		DO	
		Channel	Range	Sensor Type	Channel	Range	Channel	Contact	Channel	Type
ET-7002 PET-7002	ET-7202 PET-7202	3	±150 mV, ±500 mV, ±1V, ±5 V, ±10 V, +0 ~ +20 mA, ±20 mA, 4 ~ 20mA	-	-	-	6	Wet (Sink, Source)	3	Power Relay (Form A)
-	ET-7204 PET-7204	4	±500 mV, ±1V, ±5 V, ±10 V, +0 ~ +20 mA, ±20 mA, 4 ~ 20mA	-	4	0 ~ 5 V, ±5 V, 0 ~ 10 V, ±10 V, 0 ~ 20 mA, 4 ~ 20 mA	4	Dry (Source), Wet (Sink, Source)	-	-
ET-7016 PET-7016	-	2	±15 mV, ±50 mV, ±100 mV, ±500 mV, ±1 V, ±2.5 V, 0 ~ 20 mA, ±20 mA, 4 ~ 20mA	Strain Gauge, Load Cell, Full-Bridge, Half-Bridge, Quarter-Bridge	1 (Note)	0 ~ 10 V	2	Wet (Sink, Source)	2	Open Collector (Sink)
ET-7024 PET-7024	ET-7224 PET-7224	-	-	-	4	0 ~ 5 V, ±5 V, 0 ~ 10 V, ±10 V, 0 ~ 20 mA, 4 ~ 20 mA	5	Dry (Source), Wet (Sink, Source)	5	Open Collector (Sink)
ET-7026 PET-7026	ET-7226 PET-7226	6	±150 mV, ±500 mV, ±1 V, ±5 V, ±10 V, 0 ~ 20 mA, ±20 mA, 4 ~ 20 mA	-	2	0 ~ 5 V, ±5 V, 0 ~ 10 V, ±10 V, 0 ~ 20 mA, 4 ~ 20 mA	2	Wet (Sink, Source)	2	
ET-7028 PET-7028	ET-7228 PET-7228	-	-	-	8	-	-	-	-	-

Note: The AO is designed as a voltage excitation source for the strain gauge.

 Digital I/O

Model Name		DI/Counter			DO				
		Channel	Contact	Sink/Source	Channel	Type	Sink/Source	Load Current @ 25°C	
ET-7042 PET-7042 ET-7042UT	ET-7242 PET-7242 ET-7242UT	-	-	-	16	Open Collector	Sink	100 mA/ channel	650 mA/ channel
ET-7044 PET-7044	ET-7244 PET-7244	8	Wet	Sink/Source	8	Open Collector	Sink	300 mA /channel	650 mA/ channel
-	ET-7245 PET-7245	-	-	-	16	Open Source	Source	600 mA/channel	
ET-7050 PET-7050	-	12	Wet (Note)	Sink/Source	6	Open Collector	Sink	100 mA/channel	
-	ET-7250A PET-7250A		Dry, Wet					500 mA/channel	
ET-7051 PET-7051	ET-7251 PET-7251	16	Wet	Sink/Source	-	-	-	-	
ET-7052 PET-7052	ET-7252 PET-7252	8	Wet	Sink/Source	8	Open Collector	Source	650 mA/channel	
ET-7053 PET-7053	ET-7253 PET-7253	16	Dry	Source	-	-	-	-	
-	ET-7255 PET-7255	8	Dry, Wet	Sink/Source	8	Open Collector	Source	650 mA/channel	

 AC/DC Digital Input

Model Name		AC Digital Input					
		Channels	Contact	Sink/Source	ON Voltage Level	OFF Voltage Level	Isolation Voltage
-	ET-7258 PET-7258	8	Wet	Sink/Source	80 ~ 250 VAC ±90 ~ ±250 VDC	30 VAC (max.) ±30 VDC (max.)	Ethernet: 1500 VDC I/O: 2500 VDC
-	ET-7259 PET-7259				10 ~ 80 VAC ±15 ~ ±80 VDC	3 VAC (max.) ±3 VDC (max.)	
-	ET-7258M-16 PET-7258M-16	16	Wet	Sink/Source	80 ~ 250 VAC ±100 ~ ±250 VDC	30 VAC (max.) ±30 VDC (max.)	Ethernet: 1500 VDC I/O: 2500 VDC
-	ET-7258M-16-UTA PET-7258M-16-UTA				15 ~ 90 VAC ±20 ~ ±90 VDC	3 VAC (max.) ±3 VDC (max.)	
-	ET-7259M-16 PET-7259M-16						
-	ET-7259M-16-UTA PET-7259M-16-UTA						



(P)ET-7000 Series



(P)ET-7200 Series



(P)ET-7258M-16(-UTA) Series

Note: UTA model means the PCB is coated for operation in extreme temperatures from -40°C to +75°C.

 Relay Output & Digital Input

Model Name		DI/Counter			Relay Output			
		Channel	Contact	Sink/Source	Channel	Relay	Type	Max. Load Current @ 25°C
ET-7060 PET-7060	ET-7260 PET-7260	6	Wet	Sink/Source	6	Power Relay	Form A (SPST N.O.)	5.0 A/channel
	ET-7260A PET-7260A		Dry, Wet					
-	ET-7261 PET-7261	-	-	-	11	Power Relay	Form A (SPST N.O.)	5.0 A/channel
ET-7065 PET-7065	-	6	Wet	Sink, Source	6	PhotoMOS Relay	Form A	1.0 A/channel
ET-7066 PET-7066	-	-	-	-	8	PhotoMOS Relay	Form A	1.0 A/channel
ET-7067 PET-7067	ET-7267 PET-7267	-	-	-	8	Power Relay	Form A (SPST N.O.)	5.0 A/channel

 Encoder/Counter Input

Model Name		Encoder/Frequency/Counter Input						DO	
		Channel	Encoder	Counter	Frequency	Count Value Retention	Maximum Counting Rate	Channel	Type
ET-7083 PET-7083	-	3	CW/CCW, Dir/Pulse, AB Phase	-	-	Yes	1 MHz	-	-
-	ET-7284 PET-7284	4/8		Up or Up/Down	Yes		200 kHz	4	Open Collector

4.2 (P)ET-2200 Slim-Type Modbus TCP I/O Modules



The (P)ET-2200 modules are designed to support Ethernet I/O operations in a slim form factor for space-saving installation. The PET-2200 supports Power over Ethernet (PoE), providing both network connectivity and power over a single cable. The module features a 2-port Ethernet switch with LAN bypass functionality for easy daisy-chaining and cost savings by reducing the need for additional switches.

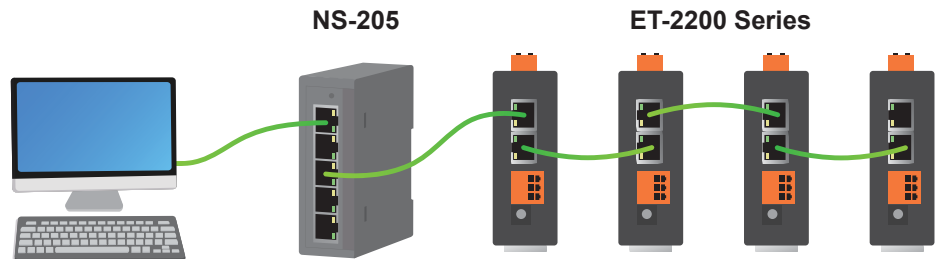

These modules include web configuration and advanced features such as high-speed 32-bit DI counters, frequency measurement, DI invert, PWM digital output, and pulse output. They offer "push mode," which automatically updates remote devices or computers with changes in local digital or analog input status, eliminating the need for busy polling. This reduces network traffic and improves system performance. Both pull and push modes are supported and can be enabled via web configuration without additional programming.

With SNMP v2C protocol support, the module allows network management software to monitor its status and I/O in real time. SNMP trap messages are sent to indicate any changes in I/O status or when the module is rebooted. The module supports Modbus TCP/UDP and MQTT v3.1 protocols, making it easy to integrate with a wide range of HMI/SCADA systems.

Features

❖ TCP Streaming Transmission for 8 kHz Analog Inputs (ET-2217H)

With an 8 kHz sampling rate on all analog inputs to acquire voltage and current data, the ET-2217H uses TCP streaming to continuously transfer data to the host PC. This method provides low-latency and high-performance transmission, making it ideal for capturing fast-changing signals. It provides uninterrupted monitoring and can be easily integrated into existing network systems.

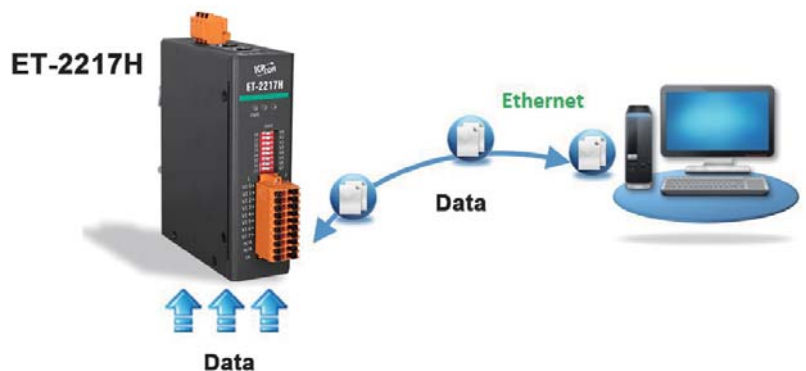

❖ Slim Housing for Optimized DIN-Rail Space Utilization

Designed with a slim profile of approximately 3.3 cm wide, more units can be installed in the same DIN-rail space. This space-saving design simplifies system organization and minimizes cabinet clutter, contributing to a more efficient setup.

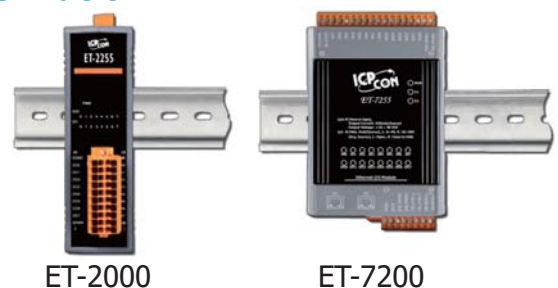

❖ Universal Digital Input or Output for (P)ET-2254(P)

The module supports flexible allocation of DI and DO channels, allowing each universal DIO channel to be configured as either input or output via a web interface or Modbus TCP protocol. This feature enables custom solutions that integrate both functions in a single unit, reducing space requirements and making it ideal for compact installations. It also reduces costs by using fewer modules, simplifies inventory management, enhances system integration and improves operational flexibility.

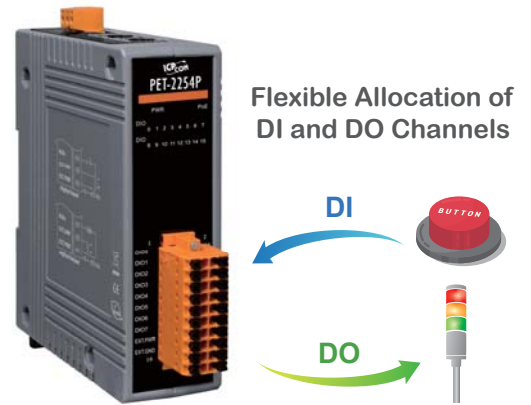

❖ 32-bit High-Speed Digital Counter

The ET-2200 modules feature a 32-bit counter on each DI channel that locally counts ON/OFF state changes. This eliminates errors due to communication delays associated with remote polling and counting. Capable of handling frequencies up to 2,500 Hz, these high-speed counters are ideal for accurate production counting, switch counting, flowmeter, and event tracking. By performing the count locally, they improve data reliability and overall system performance.

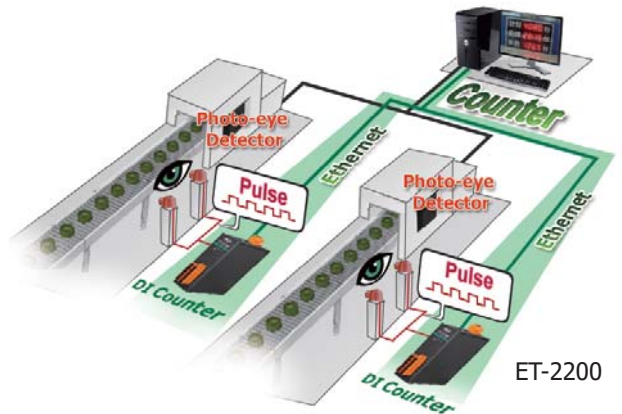

❖ DIP Switch for Easy Configuration

The DIP switch on the (P)ET-2217(H) module allows quick and easy configuration for voltage or current inputs. The physical configuration minimizes the risk of accidental changes and increases the overall versatility and ease of use of these devices.

❖ Rotary Switch for Quick Maintenance

The (P)ET-2215H(-16), (P)ET-2218H(-16)/S1, (P)ET-222xCI, and (P)ET-222xP modules feature a rotary switch for easy selection of Run or Init mode. Users can also select default IP addresses from 192.168.255.1 to 14 by setting the rotary switch. This feature is particularly useful for maintaining small automation systems, allowing seamless module replacement with the same IP address configuration selected by the rotary switch.

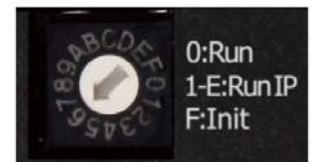

❖ Ethernet Cable Locking Hole for Stable Wiring

For reliable communication in automation systems, the (P)ET-2215H(-16) modules include Ethernet cable locking holes, preventing accidental disconnections and ensuring stable wiring.



❖ DO Minimum Switching Time for Equipment Protection

The minimum switching time limits digital output changes to protect equipment from damage caused by rapid switching and excessive ON/OFF cycles. By delaying rapid switching, this feature effectively reduces the risk of damage to sensitive equipment while increasing longevity and reliability.

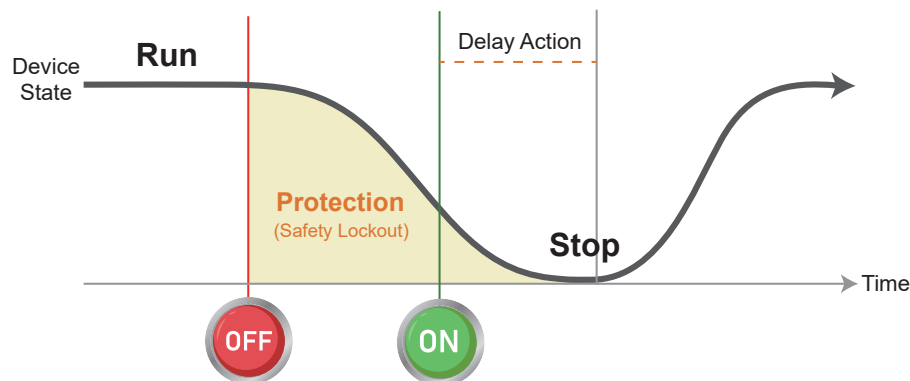

❖ DI Invert for Simplified Logic Design

Our ET-2200 DI/DO Modules feature independent inversion control on each DI channel, simplifying your logic design and eliminating the need for external signal conditioning or complex programming. You can easily configure each DI channel to operate in normal or inverted mode, reducing wiring complexity and costs for a more efficient and adaptable solution.

❖ Single Command for One-Time Digital Pulse Output (Auto-Off)

The module supports a single command for one-time pulse output, allowing users to easily activate the digital output, which then automatically turns off after a specified delay (auto-off time). By requiring only one command for both activation and deactivation, this feature simplifies operation and improves reliability by reducing the risk of missed off commands due to communication problems. This feature greatly improves operational efficiency and is particularly useful for controlling impulse relays or sending a reset (ON/OFF) signal to reboot remote devices.



❖ IPv4/IPv6 Dual-Protocol for Flexible Network Configuration

The module incorporates dual-stack technology for effective communication over both IPv4 and IPv6 networks. With SLAAC (Stateless Address Autoconfiguration), the module automatically requests IP information from the router, eliminating the need to manually set complex IPv6 addresses and ensuring seamless connectivity.

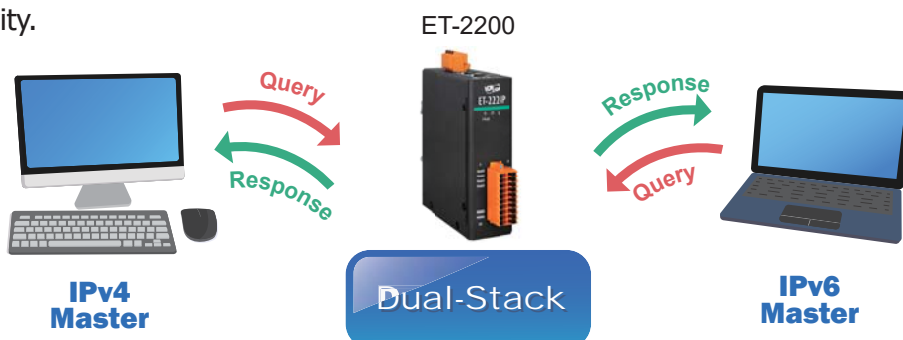

❖ Acting as a Mini Data Concentrator

(for DIO Series Modules Only)

The module can act as a mini data concentrator by using its pair-connection function. It collects data or I/O status from remote devices one by one, stores the information in shared memory, and allows the remote host to retrieve all the data at once. This approach effectively reduces the load on the host by eliminating the need to poll each device individually. In addition, the module can periodically push local I/O status or shared memory data to remote devices.

The shared memory is 256 registers (4096 bits) and supports both bit and register operations over Modbus TCP/UDP protocols. The module provides flexible data exchange between shared memory, masters, slaves, local I/O and remote I/O, making it suitable for a wide range of applications.

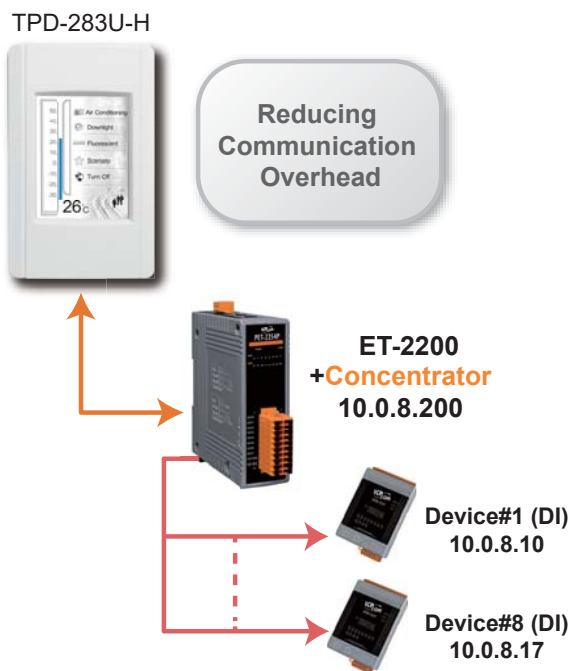

More Features

- DI Latch Function for Simplified Control Logic
- Frequency Measurement (2.5 kHz) on DI Channels
- Fast Boot (< 5 Seconds) for Immediate Operation
- PWM Output on DO Channels for Alarm Control
- I/O Pair-Connection (push/pull) for Easy Device Integration
- Analog Inputs with 16-bit High Resolution ADC, 240 Vrms Overvoltage Protection, and Channel-to-Channel Isolation (3,000 VDC)
- Rugged Design: 3000 VDC Field-to-Logic Isolation
- Up to 4 kV Contact ESD Protection for Each Terminal
- Lower Power Consumption for Energy Saving
- Power Reverse Polarity Protection for Safety
- Wide Power Input Range (+12 to +48 VDC)
- Wide Operating Temperature (-25 to +75°C)
- DIN-Rail Mounting for Stable and Quick Installation
- Dual Watchdog with Power-On and Safe Value

Selection Guide:

Model Name		UDIO		DI		DO			
Non-PoE	PoE	Ch.	Ch.	Contact	Sink/Source	Ch.	Type	Sink/Source	Max. Load @ 25°C
ET-2242	PET-2242	-	-	-	-	16	Open Collector	Sink	650 mA/Channel
ET-2242-32	PET-2242-32	-	-	-	-	32			600 mA/Channel
ET-2242U	-	-	-	-	-	16	Push-Pull	Sink/Source	500 mA/Channel
ET-2242U-32	PET-2242U-32	-	-	-	-	32	Push-Pull	Sink/Soruce	300 mA/Channel
ET-2251	PET-2251	-	16	Wet/Dry	Sink/Source	-	-	-	-
ET-2251-32	PET-2251-32	-	32			-	-		
ET-2254	PET-2254	16	(Note1)	Dry	Source	(Note1)	Open Collector	Sink	100 mA/Channel
ET-2254P	PET-2254P		-			350 mA/Channel			
ET-2255	PET-2255	-	8	Wet/Dry	Sink/Source	8	Open Collector	Sink	650 mA/Channel
ET-2255-32	PET-2255-32	-	16			16			500 mA/Channel
ET-2255U	PET-2255U	-	8			8	Push-Pull	Sink/Source	

Note1: The number of DI/DO channels is depending on wiring and the software configuration.

Note2: All DI/DO modules support both MQTT and SNMP V2c protocols.

Model Name		DI			Relay Output			
Non-PoE	PoE	Ch.	Contact	Sink/Source	Ch.	Relay	Type	Contact Rating
ET-2260	PET-2260	6	Wet/Dry	Sink/Source	6	Power Relay	Form A (SPST N.O.)	5 A @ 250 VAC/24 VDC (Resistive Load)
ET-2261	PET-2261	-	-	-	10			
ET-2261-16	PET-2261-16	-	-	-	16			
ET-2268	-	-	-	-	8	Signal Relay	4 Form A, 4 Form C	2 A @ 30 VDC 0.25 A @ 250 VDC

Model Name		AI				Protocol	
Non-PoE	PoE	Ch.	Sampling Rate	Voltage and Current Input	Ch-to-Ch Isolation	MQTT	SNMP V2c
ET-2217	PET-2217	8/16	Normal: 20 Hz Fast: 200 Hz (Total Channels)	± 150 mV, ± 500 mV, ± 1 V, ± 2.5 V, ± 5 V, ± 10 V, ± 20 mA, $0 \sim +20$ mA, $+4 \sim +20$ mA	-	Yes	
ET-2217CI-4	-	4	Normal: 10 Hz Fast: 200 Hz (Each Channel)	± 1 V, ± 2.5 V, ± 5 V, ± 10 V, ± 20 mA	Yes	Yes	-
ET-2217CI	-	8				-	

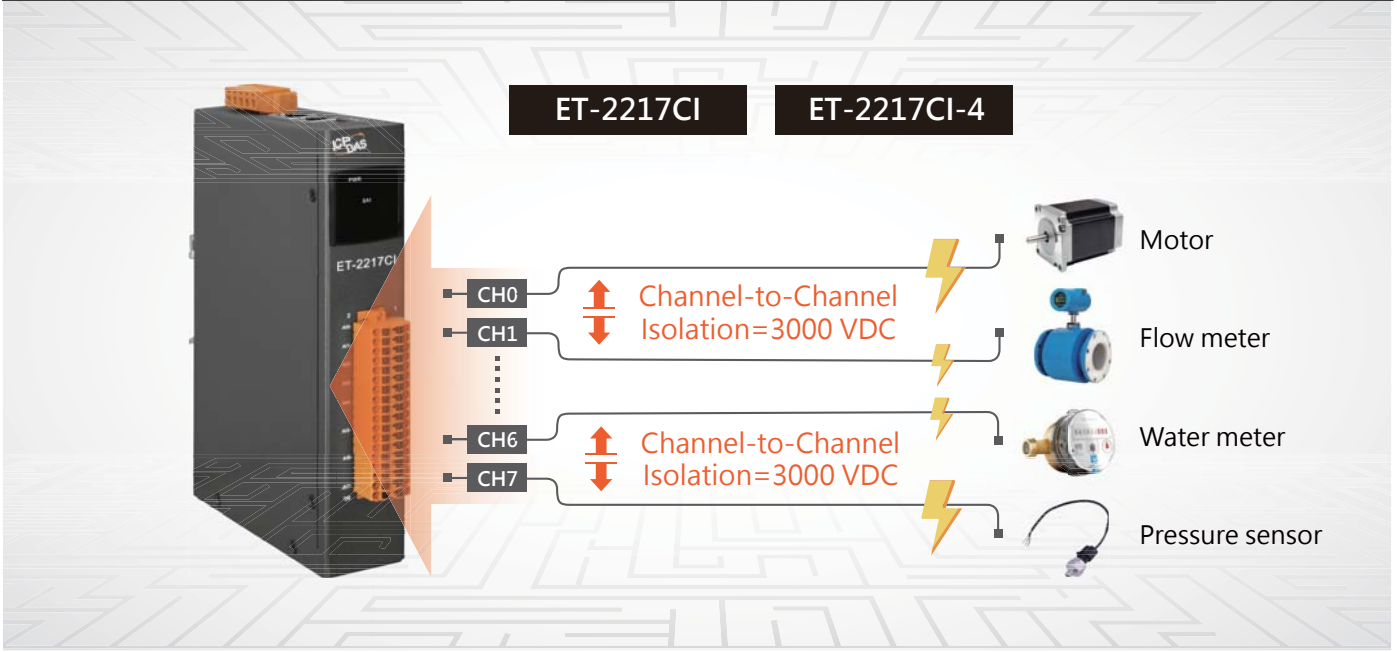

Model Name		AO				Protocol		
Non-PoE	PoE	Channels	Resolution	Voltage Output	Current Output	Channel-to-Channel Isolation	MQTT	SNMP V2c
ET-2224	PET-2224	4	12-bit	$0 \sim +5$ V, $0 \sim +10$ V, ± 5 V, ± 10 V	$0 \sim +20$ mA, $+4 \sim +20$ mA	-	Yes	
ET-2228	PET-2228	8						
ET-2224CI	-	4	16-bit	$0 \sim +5$ V, $0 \sim +10$ V		Yes	Yes	-
ET-2228CI	-	8						

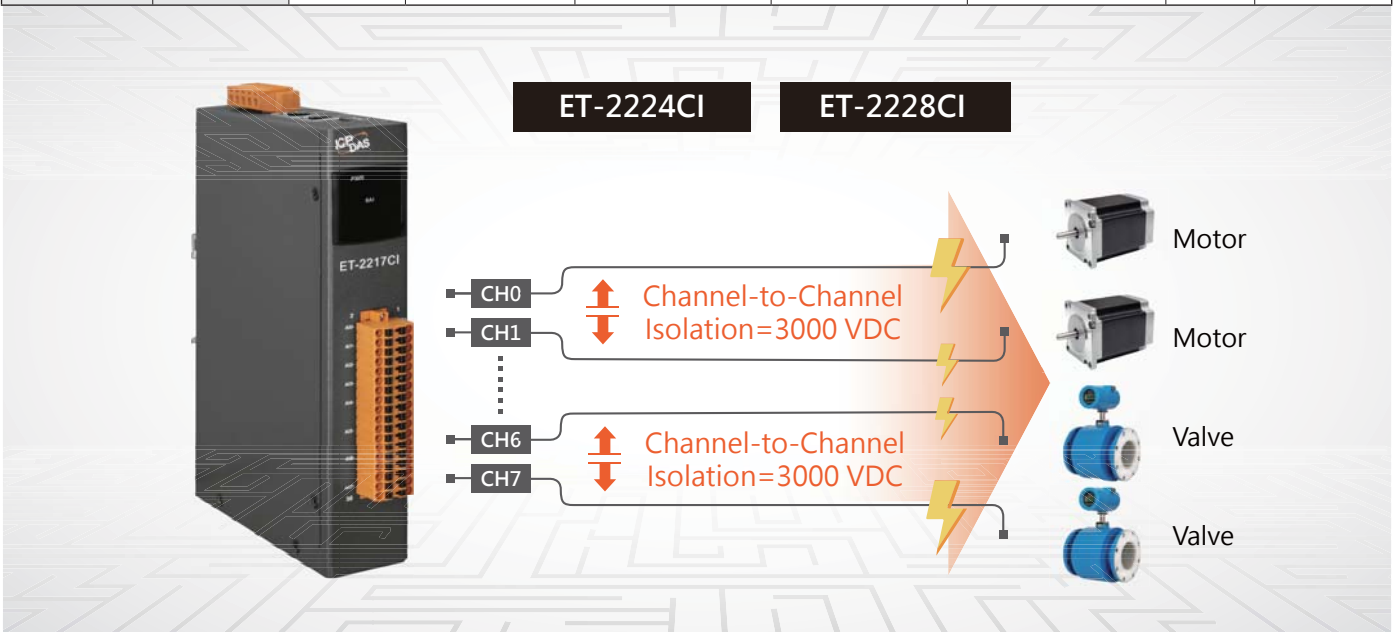

4.3 tET/tPET Tiny-Size Modbus TCP I/O Modules



The tET/tPET series Ethernet I/O modules feature a small size for easy integration in tight or confined spaces, web-based configuration, and a variety of I/O functions such as DIO, AIO, high-speed 32-bit counter, frequency measurement, DI invert, and PWM output. Its small size and low channel count make it ideal for distributed I/O applications such as machine or room control and monitoring. The tPET supports PoE, which provides both network connectivity and power over a single cable, simplifying Ethernet cabling.

The module supports Modbus TCP/UDP, MQTT v3.1 and SNMP v2c protocols, ensuring compatibility with a wide range of HMI/SCADA systems for versatile integration.

Application:

- Remote Maintenance
- Testing Equipment
- Building Automation
- Factory Automation
- Machine Automation

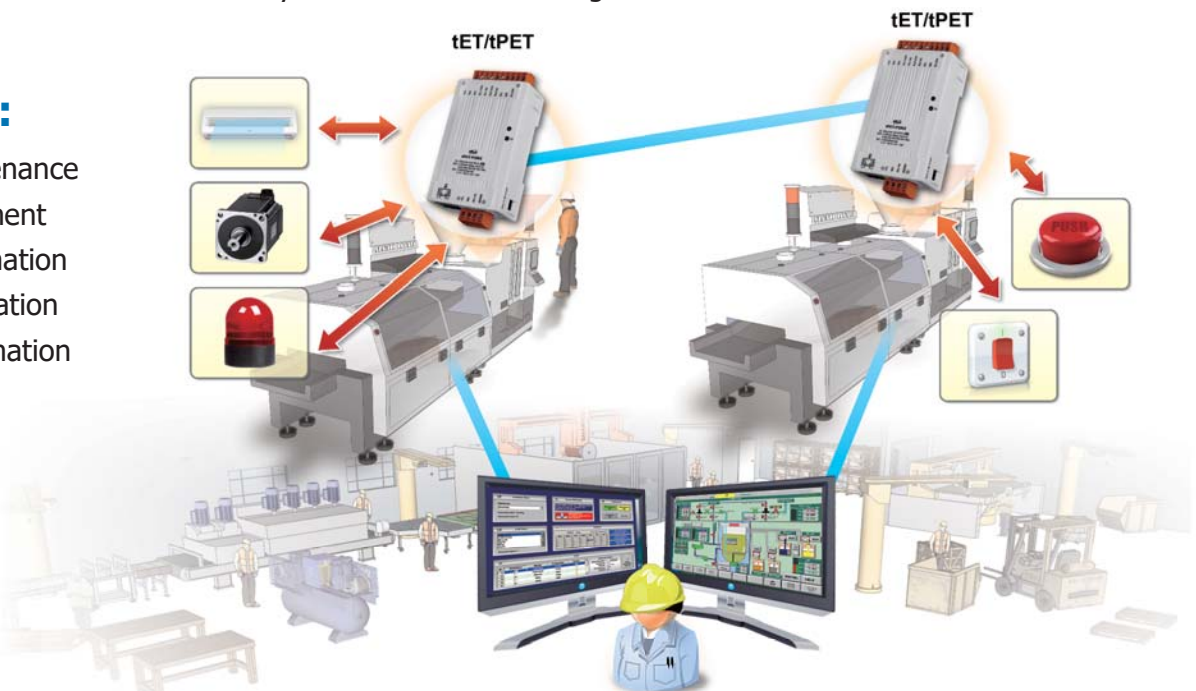

Features:

❖ 32-bit High-Speed Digital Counter

The tET/tPET modules feature a 32-bit counter on each DI channel that locally counts ON/OFF state changes. This eliminates errors due to communication delays associated with remote polling and counting. Capable of handling frequencies up to 2,500 Hz, these high-speed counters are ideal for accurate production counting, switch counting, flowmeter, and event tracking. By performing the count locally, they improve data reliability and overall system performance.

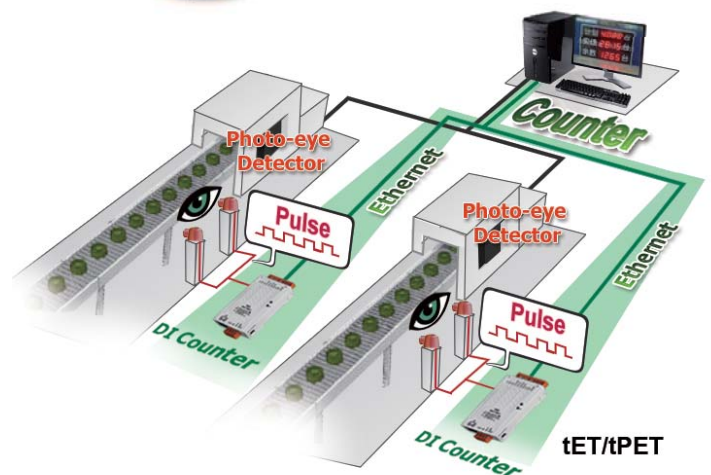

❖ Frequency Measurement

Using the 32-bit high-speed digital counter values, the module calculates the frequency over a specified period of time. Local calculation eliminates errors caused by communication delays in remote polling and counting. For greater flexibility, the module offers three scan modes (0.1s, 1s, and single-pulse) and four moving average levels, allowing users to select the best settings for applications such as rotation and speed measurements.

❖ I/O Pair-Connection: Efficient I/O Mapping Over Ethernet

The module enables a DI-to-DO (or AI-to-AO) pair connection over Ethernet using the Modbus TCP protocol. Its "push mode" instantly updates remote devices when local input status changes, eliminating the need for frequent polling. This enhances system performance while reducing network traffic. Users can effortlessly activate both pull and push modes via a web-based configuration, with no additional programming required.

This feature is particularly beneficial for traditional I/O devices without built-in Ethernet capabilities that still require I/O status exchange over an Ethernet network. By leveraging this module, legacy devices can seamlessly integrate into modern Ethernet-based systems without complex modifications.

Pull Mode:
Remote inputs to Local outputs

Push Mode:
Local inputs to Remote outputs

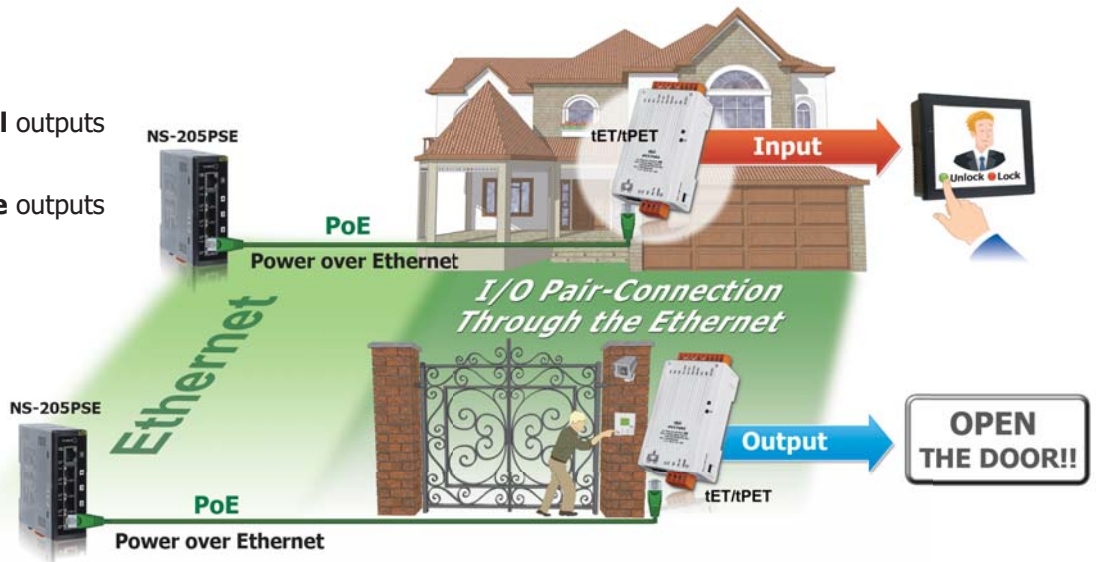

❖ PWM (Pulse Width Modulation) Digital Output

The PWM (Pulse Width Modulation) function on the DO channels of the tET/tPET modules supports applications such as alarm and flash light control. Once configured, the module continuously turns the PWM output on and off, eliminating the need for remote control and reducing network load. Users can set the duty cycle for the PWM outputs to operate simultaneously. This simplifies the control system and improves the precision of the pulse output timing.

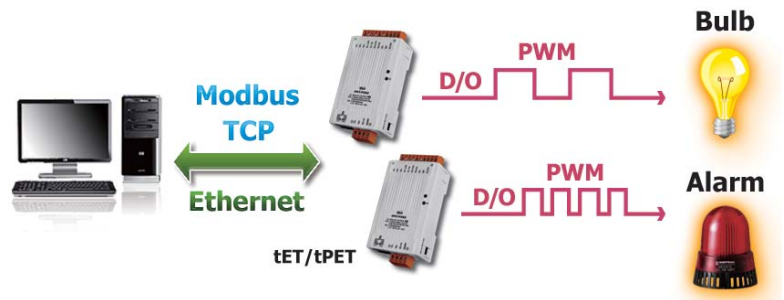

❖ Single Command for One-Time Digital Pulse Output (Auto-Off)

The module supports a single command for one-time pulse output, allowing users to easily activate the digital output, which then automatically turns off after a specified delay (auto-off time). By requiring only one command for both activation and deactivation, this feature simplifies operation and improves reliability by reducing the risk of missed off commands due to communication problems. This feature greatly improves operational efficiency and is particularly useful for controlling impulse relays or sending a reset (ON/OFF) signal to reboot remote devices.

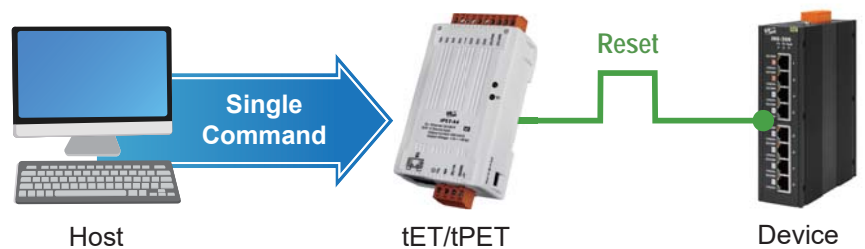

❖ Real-Time Monitoring and Scalable Integration with SNMP v2C

With SNMP v2C protocol support, the module enables real-time monitoring of its status and I/O through network management software. Automatic SNMP trap messages notify any changes in I/O status or when the module is rebooted, ensuring quick responses to critical events. The module's seamless integration with existing network management tools reduces setup complexity, while its scalability supports large-scale deployments, enabling centralized monitoring of multiple modules. By leveraging SNMP v2C, the module enhances operational efficiency, improves system control, and reduces maintenance costs.

❖ DO Minimum Switching Time for Equipment Protection

The minimum switching time limits digital output changes to protect equipment from damage caused by rapid switching and excessive ON/OFF cycles. By delaying rapid switching, this feature effectively reduces the risk of damage to sensitive equipment while increasing longevity and reliability.

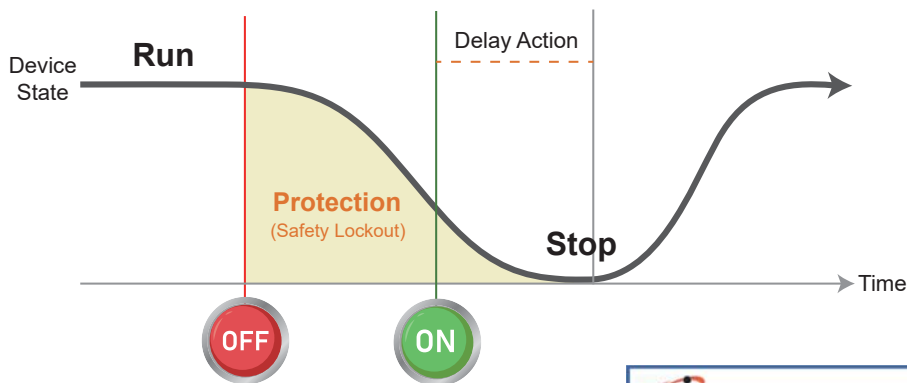

❖ Easy Configuration

The tET/tPET modules support DHCP to automatically obtain TCP/IP settings, reducing IP address conflicts. They feature a UDP responder that reports IP/mask/gateway information when searching with the eSearch utility, simplifying local management. The modules also include a built-in web server for easy configuration of I/O, network settings, and more.

The screenshot shows the web interface for the ICP DAS Ethernet I/O Module. The interface includes a navigation menu with options like Home, Network, I/O Settings, Sync, PWM, Pair, Filter, Monitor, Password, and Logout. It also has a search bar for MQTT topics (DO, DI) and SNMP. The main content area displays configuration details for the Model Name (tPET-P2R2_RevB), Firmware Version (B2.4.2), IP Address (192.168.79.1), and TCP Timeout (180). It also shows the Alias Name (tPET #1), MAC Address (00-0d-e0-65-fa-7f), Initial Switch (OFF), and System Timeout (0). Below this, there is a section for Digital I/O (Modbus Address: DO=00000 to 00015, DI=10000 to 10015) with a table of DO channels (DO0 to DO7) and their status (High Latched, Low Latched).

DI Channel	Value (10000)	Counter (30016) / Frequency (30064)	High Latched (10032)	Low Latched (10064)
DI0	●	-	-	-
DI1	●	-	-	-
DI2	-	-	-	-
DI3	-	-	-	-
DI4	-	-	-	-
DI5	-	-	-	-
DI6	-	-	-	-
DI7	-	-	-	-

Note: Above Modbus addresses are all 0 based.

❖ Dual Watchdog with Power-on and Safe Value

To ensure system reliability, stability, and continuous operation, this module incorporates a Dual Watchdog design. The hardware watchdog automatically resets the MCU if it detects a module freeze, preventing it from stopping working. This reset loads the AO/DO values according to user-defined power-on settings. The software watchdog monitors communication activity between the host controller and the module. If the watchdog timeout occurs, the module switches its outputs to predefined safe values to prevent incorrect operation.

❖ PoE (Power over Ethernet)

The tPET modules support PoE (Power over Ethernet), which allows both network connectivity and power to be supplied through a single cable, simplifying Ethernet cabling. The tET/tPET modules also accept power from a DC adapter.

More Features

- DI Invert for Simplified Logic Design
- DI Latch Function for Easy Control
- 16-bit High Resolution ADC for Analog Inputs
- Analog Inputs with 120 VDC Overvoltage Protection
- Fast Boot (< 5 Seconds) for Immediate Operation
- Up to 4 kV Contact ESD Protection for Each Terminal
- Rugged Design: 3000 VDC Field-to-Logic Isolation
- Lower Power Consumption for Energy Saving
- Power Reverse Polarity Protection for Safety
- Wide Power Input Range (+12 to +48 VDC)
- Wide Operating Temperature (-25 to +75°C)
- DIN-Rail Mounting for Stable and Quick Installation
- IPv4/IPv6 Dual-Protocol for Flexible Network Configuration

Selection Guide:

Analog Input/Analog Output

Model Name		AI				AO		
PoE	Non-PoE	Channels	Sampling Rate	Resolution	Voltage & Current Input	Channels	Resolution	Voltage & Current Output
tPET-AD2	tET-AD2	2	200 Hz	16-bit	0 ~ 500 mV, 0 ~ 1 V, 0 ~ 2.5 V, 0 ~ 5 V, 0 ~ 10 V, 0 ~ 20 mA, 4 ~ 20 mA	-	-	-
tPET-DA2	tET-DA2	-	-	-	-	2	12-bit	0 ~ 10 V, 0 ~ 20 mA, 4 ~ 20 mA

Digital Input/Digital Output

Model Name		DI			DO			
PoE	Non-PoE	Channels	Contact	Sink/Source	Channels	Type	Sink/Source (NPN/PNP)	Max. Load @ 25 ° C
tPET-P6	tET-P6	6	Wet	Sink/Source	-	-	-	-
tPET-PD6	tET-PD6	6	Dry	Source	-	-	-	-
tPET-C4	tET-C4	-	-	-	4	Open Collector	Sink (NPN)	100 mA/channel
tPET-A4	tET-A4	-	-	-	4	Open Emitter	Source (PNP)	650 mA/channel
tPET-P2C2	tET-P2C2	2	Wet	Sink/Source	2	Open Collector	Sink (NPN)	100 mA/channel
tPET-P2A2	tET-P2A2	2	Wet	Sink/Source	2	Open Emitter	Source (PNP)	650 mA/channel

Relay Output/Digital Input

Model Name		DI			Relay Output			
PoE	Non-PoE	Channels	Contact	Sink/Source	Channels	Relay	Type	Load Current
tPET-P2POR2	tET-P2POR2	2	Wet	Sink/Source	2	PhotoMOS Relay	Form A	1.0 A/channel
tPET-PD2POR2	tET-PD2POR2	2	Dry	Source	2	PhotoMOS Relay	Form A	1.0 A/channel
tPET-P2R2	tET-P2R2	2	Wet	Sink/Source	2	Power Relay	Form A (SPST N.O.)	5.0 A/channel
tPET-PD2R1	tET-PD2R1	2	Dry	Source	1	Power Relay	Form A (SPST N.O.)	5.0 A/channel

4.4 MQ-7200M MQTT I/O Modules

The MQ-7200M series is an Ethernet I/O module with multiple digital I/O channels for connecting a variety of digital sensors. It supports the MQTT protocol for Industrial Internet of Things (IIoT) applications. MQTT is a lightweight protocol for machine-to-machine (M2M) connectivity that uses publish/subscribe messaging model. It is ideal for mobile applications due to its small size, low power consumption, minimized data packets, and efficient distribution of information to one or more receivers.

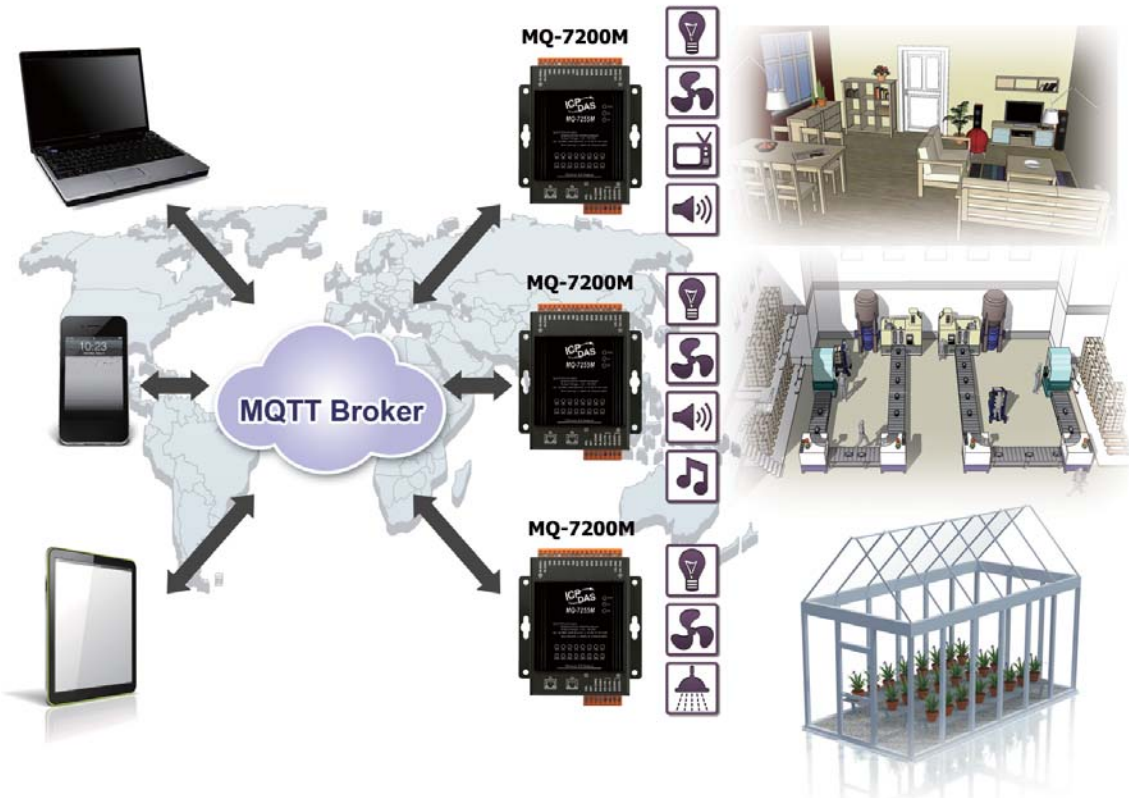

With MQTT support, the MQ-7200M module enables lightweight, reliable, and low-latency communication between devices. The module can publish Digital I/O (DIO) status updates to an MQTT broker and subscribe to control messages for Digital Outputs (DO). Users can easily control and monitor remote sensors connected to the MQ-7200M modules using MQTT client tools on computers or mobile devices. This provides a flexible and scalable solution for IIoT applications requiring distributed control and monitoring.

Appearance:

Applications:

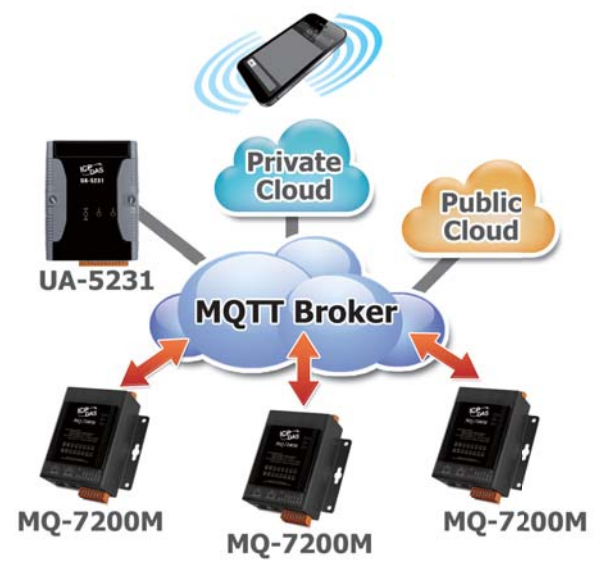
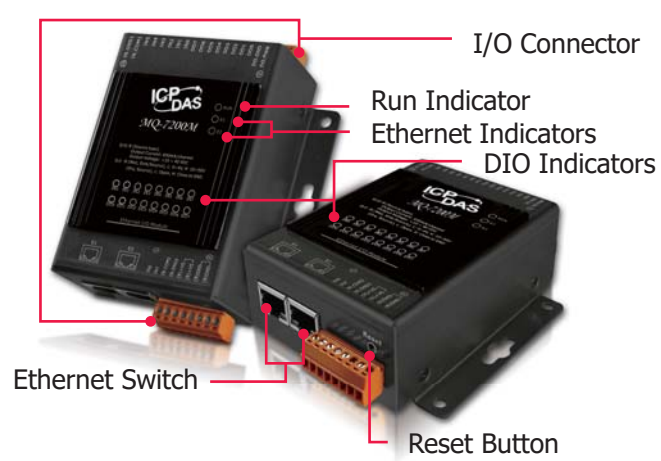

Features:

❖ Support MQTT and Modbus TCP for Flexible System Integration

Support both the MQTT client (compliant with the MQTT V3.1 protocol) and the widely used Modbus TCP protocol for industrial automation. These protocols work simultaneously, providing flexibility and simplifying system integration. This enables seamless remote monitoring and control via SCADA systems or IIoT platforms.

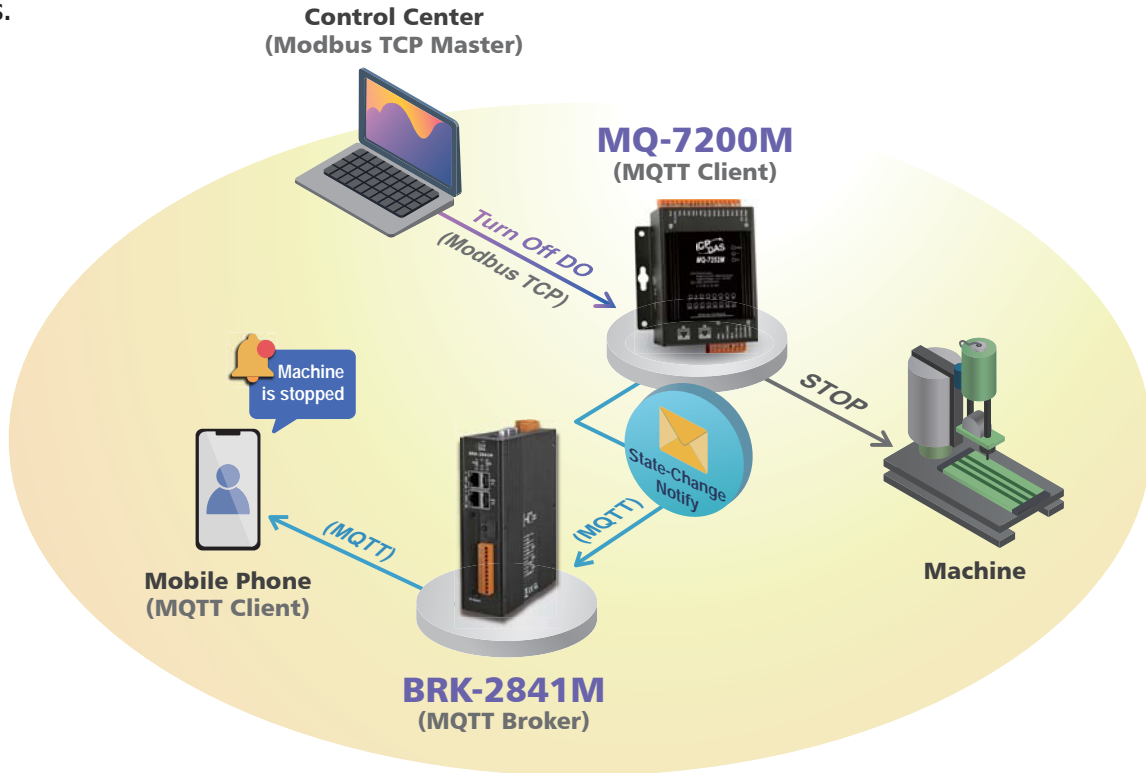

❖ Automatic Hostname Resolution for Simplified MQTT Connectivity

The MQ-7200M modules automatically query the DNS server to resolve the MQTT broker's hostname into an IP address and establish the connection. They support both IP and hostname configuration for the MQTT broker, simplifying network setup and increasing flexibility. By using a hostname, the broker can easily switch to a new IP address without reconfiguring each device, improving system reliability and uptime while reducing administrative overhead.



❖ Automatic Connection Management for Reliable MQTT Integration

The module automatically sends a keep-alive packet to the broker to ensure the connection remains active. If the connection is lost, the module automatically reconnects to the broker. These features are built into the module and are enabled without the need for additional programming, making MQTT system integration faster and easier. This not only simplifies setup, but also ensures continuous communication, increases system reliability, and minimizes the risk of connection loss.

❖ Efficient and Scalable MQTT-Based Status Updates

I/O status can be published via MQTT messages either when a status change occurs or at periodic intervals. With no busy polling, this results in faster response times and more efficient use of system resources. It is also highly scalable, allowing systems with a large number of devices to operate smoothly without significantly increasing network load, as each device communicates only when needed.

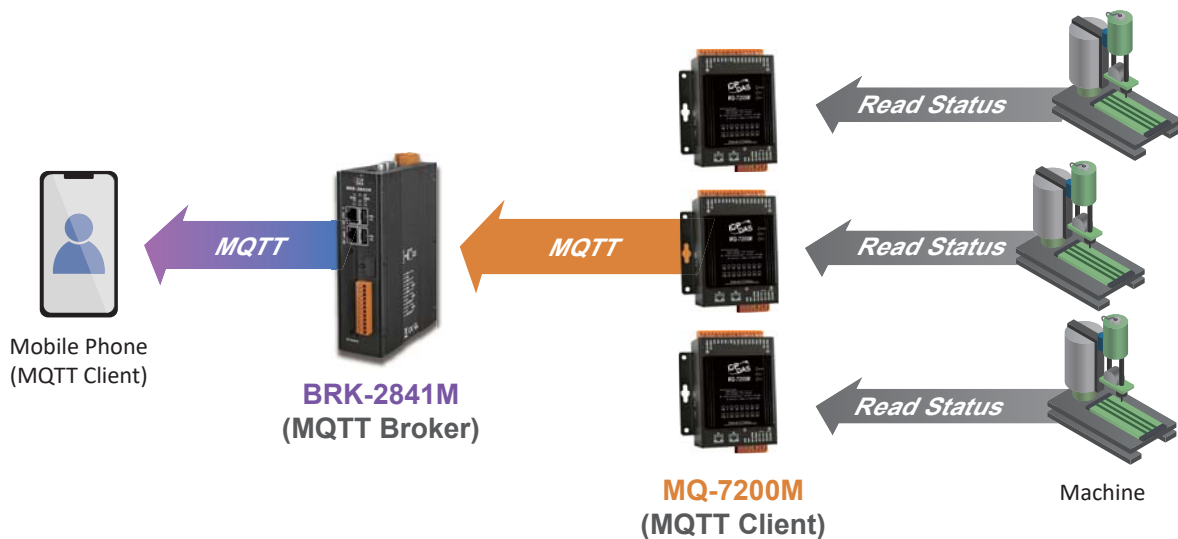

❖ Daisy-Chain Ethernet Cabling for Total Cost Reduction

With two built-in Ethernet switch ports, the MQ-7200 modules can be easily daisy-chained to extend the Ethernet network. This reduces overall costs by eliminating the need for additional switches, making the modules ideal for compact or space-constrained environments. Integration simplifies cabling, lowers hardware and installation costs, reduces network management complexity and provides greater flexibility to expand or adapt the network.



❖ LAN Bypass for Stable Ethernet Communication

The LAN bypass function is automatically activated during a power failure, ensuring continuous communication on the Ethernet ports and keeping the system operational. This minimizes downtime and enhances the overall reliability and robustness of the system.

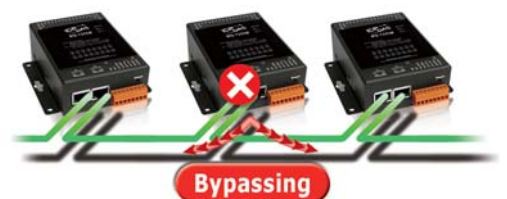

❖ Built-in WEB Server for Easy Configuration

The MQ-7200M modules include a web-based interface that allows users to configure the device, monitor network connectivity and I/O status, and control the DO lines using popular web browsers on both mobile devices and computers. Its intuitive design also allows for quick I/O testing without programming, making it especially useful for pre-project setup or troubleshooting I/O operations.

Connection Status:  = Good,  = Disconnection



The device used to log in to the MQ-7200M



MQ-7200M



MQTT broker



I/O	No.	Topic	Status
Digital Output	0	F001/Get_Value/DO_0	OFF
Digital Output	1	F001/Get_Value/DO_1	OFF
Digital Output	2	F001/Get_Value/DO_2	OFF
Digital Output	3	F001/Get_Value/DO_3	OFF
Digital Output	4	F001/Get_Value/DO_4	OFF
Digital Output	5	F001/Get_Value/DO_5	OFF
Digital Output	6	F001/Get_Value/DO_6	OFF
Digital Output	7	F001/Get_Value/DO_7	OFF

More Features

- Short-Circuit Protection on Digital Outputs
- Overvoltage Protection on Digital Outputs and Inputs
- LED Indicators for I/O Status Monitoring and Easy Diagnostics
- Reset Button for Easy Restoration of Factory Settings
- Dual Watchdog with Power-On and Safe Value
- Fast Startup (< 5 seconds) for Immediate Operation
- Wide Power Input Range (+12 to +48 VDC)
- Lower Power Consumption for Energy Saving
- Two Pairs (4 Pins) of Power Inputs for Flexible Wiring
- Power Reverse Polarity Protection for Improved Safety
- Wide Operating Temperature Range (-25 ~ +75°C)
- Up to +/- 4kV Contact EMS Protection on Each Terminal
- Metal Enclosure for Enhanced Durability and Protection
- DIN-Rail and Wall Mounting for Stable and Quick Installation

Application:

Versatile Smart Home Connectivity with MQTT and Modbus

In a smart home environment, MQTT and Modbus are commonly used data transmission protocols, each suited to different scenarios:

MQTT is a lightweight protocol designed for real-time data transmission, especially for devices with limited bandwidth. The MQ-7200M publishes I/O status to a centralized broker, which then distributes these updates to subscribed clients. This publish-subscribe model is ideal for smart home devices that may temporarily lose and then resume a connection. A key advantage of MQTT is that it establishes outgoing-only connections to the broker, eliminating the need for incoming connections, preventing unauthorized access, and enhancing local network security.

Modbus operates on a request-response model, where a client sends a request to MQ-7200M, and the MQ-7200M responds with data. This protocol is ideal for tasks such as turning lights on or off or retrieving sensor data from the MQ-7200M. Modbus is particularly well suited for local network communication, providing reliable and easy control and monitoring of devices.

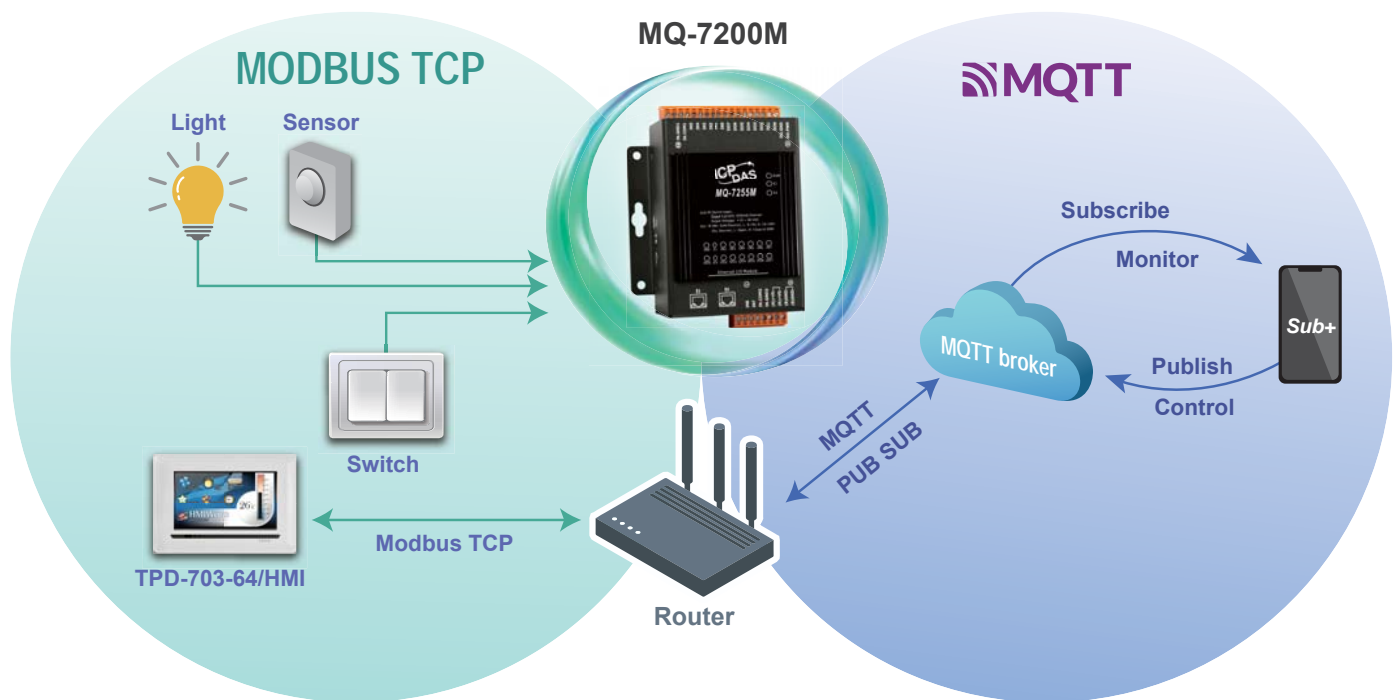

Selection Guide:

Module Name	DI			DO			
	Channels	Type	Sink/Source	Channels	Type	Sink/Source	Load Current @ 25 °C
MQ-7244M	8	Wet	Sink/Source	8	Open Collector	Sink	650 mA/Channel
MQ-7252M		Wet				Source	
MQ-7255M		Dry, Wet				Source	
MQ-7251M	16	Wet	Sink/Source	-	-	-	-
MQ-7253M		Dry	Source				
MQ-7260AM	6	Dry, Wet	Sink/Source	6	Power Relay	Form A	5A



PAC & PAC I/O Modules

- 5.1 ET-8KPN-MTCP Series I/O Expansion Units- - - - - P 87
- 5.2 I-8KW and I-87KW I/O Modules - - - - - P 93

5.1 ET-8KPN-MTCP Series I/O Expansion Units

ET-8KPN-MTCP / ET-87PN-MTCP / iP-8x41-MTCP are Modbus TCP I/O expansion units to extend I-8KW or I-87KW series I/O modules (see Chapter 5.2) via Ethernet for industrial applications. It supports more than 100 I/O modules, including analog I/O, digital I/O, counter and frequency I/O modules. Designed for use in harsh and noisy environments, it supports a wide power input range (10 ~ 30 VDC), isolated power inputs, and operates over a wide temperature range (-25 ~ +75 °C). To simplify I/O module installation and maintenance, the units support I/O module auto-configuration, LED indicators for fault detection. It also supports dual watchdogs with programmable power-on and safe values to keep the system active for increased system reliability and stability.

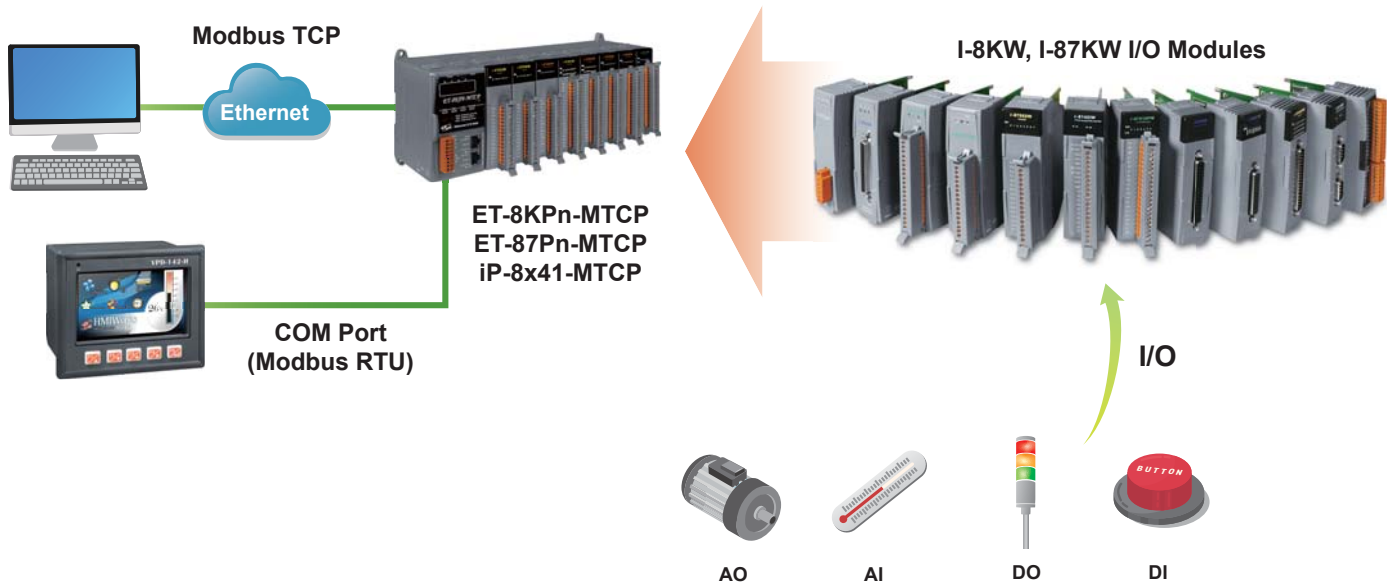

Modbus is a very well-known protocol in industrial manufacturing and environmental monitoring. Many SCADA, HMIs and PLCs systems have built-in drivers to support Modbus devices.

The ET-87PN is a remote intelligent I/O expansion unit that expands the I-87KW I/O modules via Ethernet using the DCON protocol. Most of the features are the same as the ET-87PN-MTCP except that it does not have Modbus related features.

Comparison Table

Product Line	iP-8x41-MTCP	ET-8KPN-MTCP	ET-87PN-MTCP	ET-87PN
Ethernet	2 (Dual LAN)	2 (Switch ports)	2 (Switch ports)	2 (Switch ports)
Daisy-Chain Cabling	-	Yes	Yes	Yes
Protocol	Modbus TCP	Modbus TCP	Modbus TCP	DCON
SDK	-	-	-	PACSDK
I-8KW Modules	Yes	Yes	-	-
I-87KW Modules	Yes	Yes	Yes	Yes
I/O Slots	4 / 8	4 / 8	4 / 8	4 / 8
I/O Hot Swap	-	-	Yes	Yes
COM ports	4	1	1	1

Features:

❖ Hot-Swap and Auto-Configuration for Easy Maintenance (ET-87Pn)

The ET-87Pn expansion unit allows I-87KW I/O modules to be replaced or added without powering down the entire system. I-87KW modules can be pre-configured and the settings such as input/output ranges and safety values can be stored in the ET-87Pn. When the ET-87Pn is powered on or an I/O module is plugged in, it automatically checks and restores the configurations for each I/O module connected to it. Auto-Configuration allows for easy maintenance without the need for a PC or laptop, minimizing downtime and improving overall system reliability.

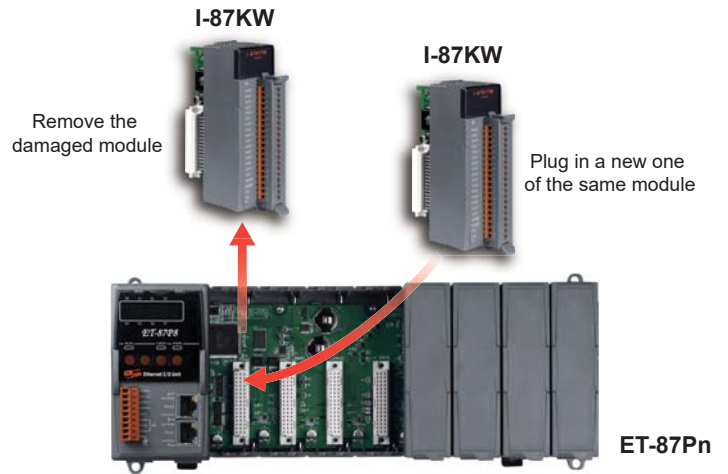

❖ Scalable I/O Capacity Supporting Up to 256 Digital Channels

The expansion unit supports up to 256 digital I/O channels, 160 analog inputs (AI), and 64 analog outputs (AO) in a compact form factor. Users can customize their system by selecting the most appropriate modules to meet their specific needs, providing flexible and extensive I/O capacity for a variety of applications. This scalability allows the system to accommodate large and complex industrial automation setups.

❖ Single Connection to Access Multiple I/O Channels

The expansion unit can manage multiple inputs and outputs simultaneously. All I/O channels on the installed modules are accessible through a single TCP connection, eliminating the need to poll each module via separate IP addresses. This setup improves system performance, increases network efficiency, and reduces overhead.

❖ Concurrent Access via Multiple Modbus TCP Masters

It supports concurrent access from multiple computers or controllers, greatly improving I/O system scalability. This enables more comprehensive monitoring, control, and diagnostics in automation systems, improving overall system performance and responsiveness, especially in complex or large-scale applications.

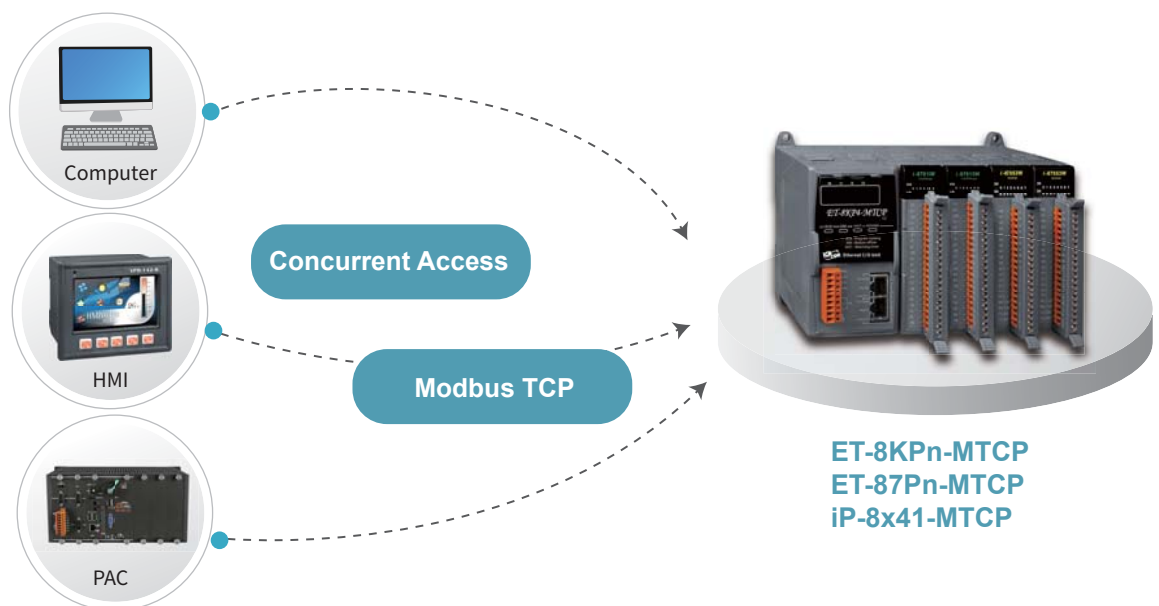

❖ Modbus TCP/RTU/ASCII Protocols

These protocols are widely used in industrial automation and ensure that the devices can be easily integrated with a wide range of HMI/SCADA software and other devices. The broad compatibility of these protocols makes the system adaptable to various existing installations, reducing integration complexity and time.

❖ Flexible Communication Interfaces for Seamless Integration

The unit supports Ethernet, RS-232, and RS-485 connections for SCADA/HMI systems, providing users the flexibility to choose the most appropriate communication interface for their specific setup. Modbus RTU Slave or Modbus ASCII Slave functionality can be easily configured for the serial ports, simplifying system integration and minimizing the need for additional adapters or interfaces.

❖ Modbus Gateway and Virtual COM (VxComm)

The expansion unit supports Modbus TCP and Modbus RTU protocol conversion through the Modbus Gateway function, simplifying device integration without the need for additional protocol converters or gateways, reducing overall costs. It also supports access to devices via raw data communication through Virtual COM (VxComm), increasing compatibility across a wide range of systems and devices and improving system flexibility.

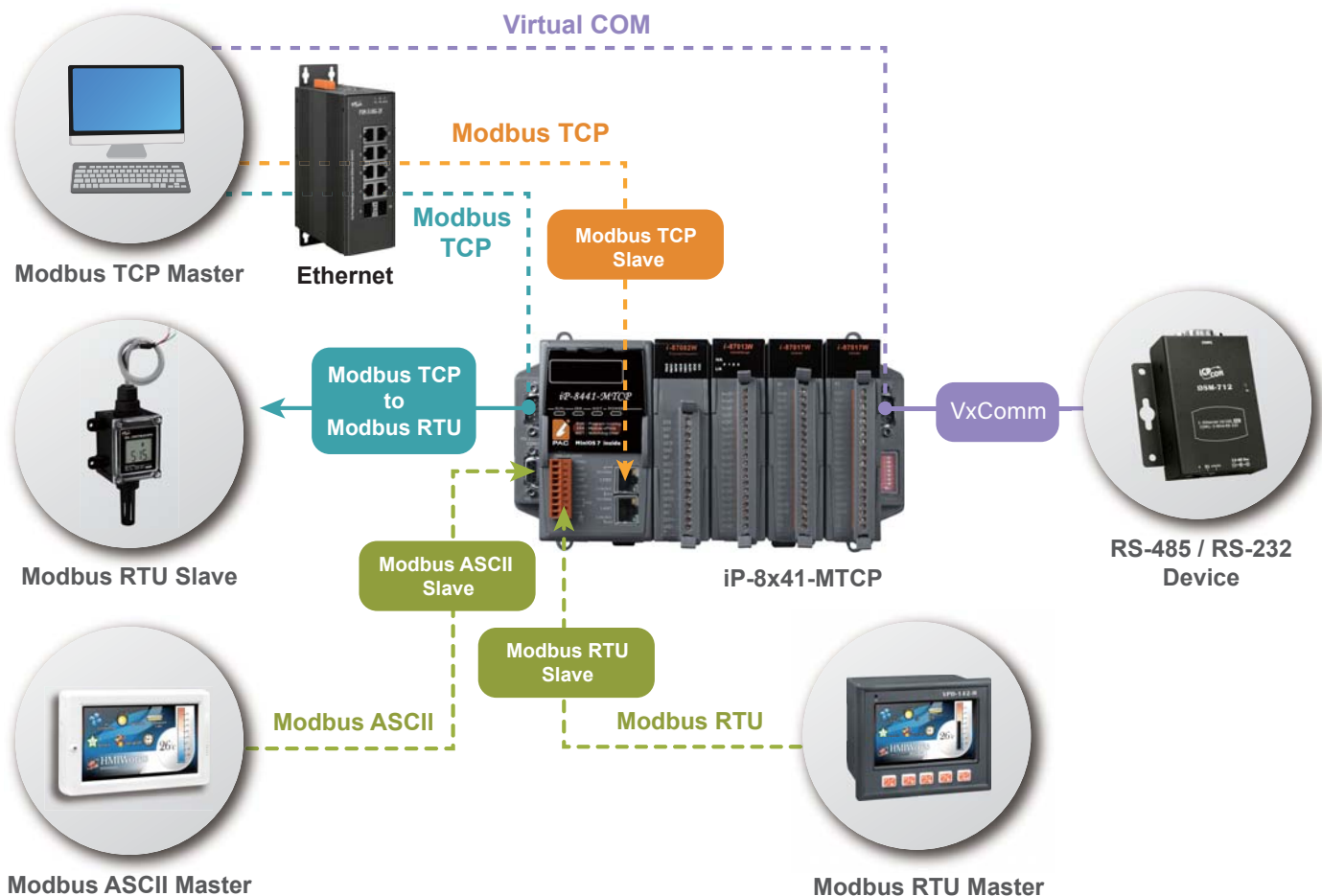

❖ Power-On and Safe Value for Enhanced Safety Protection

This feature ensures that outputs are set to predefined values upon system startup or communication failure, reducing the risk of malfunction or unsafe operation. Helps organizations meet stringent safety standards and regulations to protect people and equipment in critical systems.

❖ Daisy-Chain Ethernet Cabling for Total Cost Reduction

The ET-8KPn-MTCP / ET-87Pn-MTCP / ET-87Pn expansion units provide two Ethernet switch ports that can be easily daisy-chained to expand the network. This reduces overall costs by eliminating the need for additional switches, making the units ideal for compact or space-constrained environments. Integration simplifies cabling, lowers installation costs, reduces network management complexity, and provides greater flexibility to expand or adapt the network.

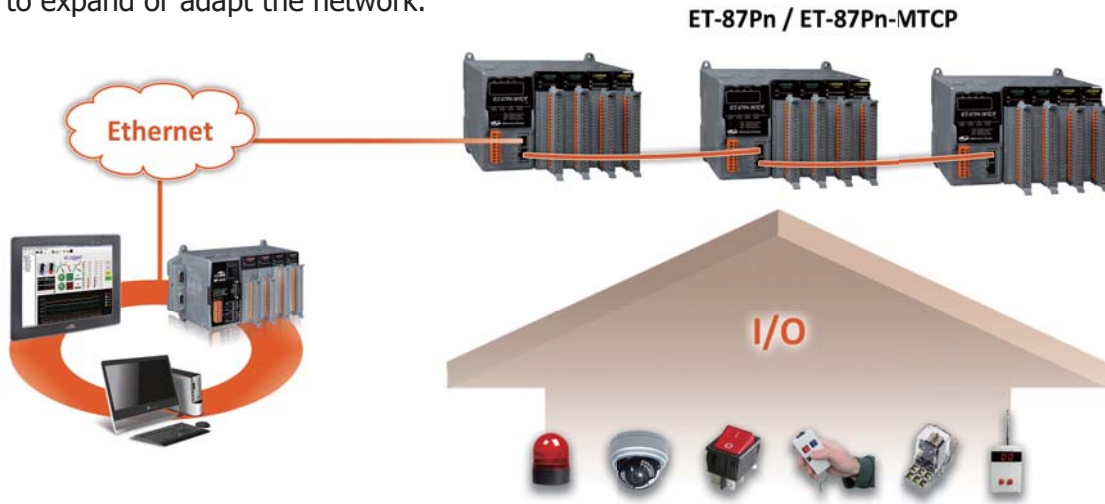

❖ Dual LAN for Enhanced Flexibility, Redundancy, and Scalability

The iP-8x41-MTCP expansion unit provides two Ethernet ports for Dual LAN applications, allowing controllers on separate networks to access I/O data within the same unit using the Modbus TCP protocol. By isolating the two networks during I/O operations, Dual LAN increases both network security and performance. Dual LAN provides continuous operation with network redundancy, maintaining system reliability and minimizing downtime even if one network fails. This feature provides greater flexibility in network design, simplifies system setup and maintenance, and allows for easy integration with a wide variety of devices and networks.

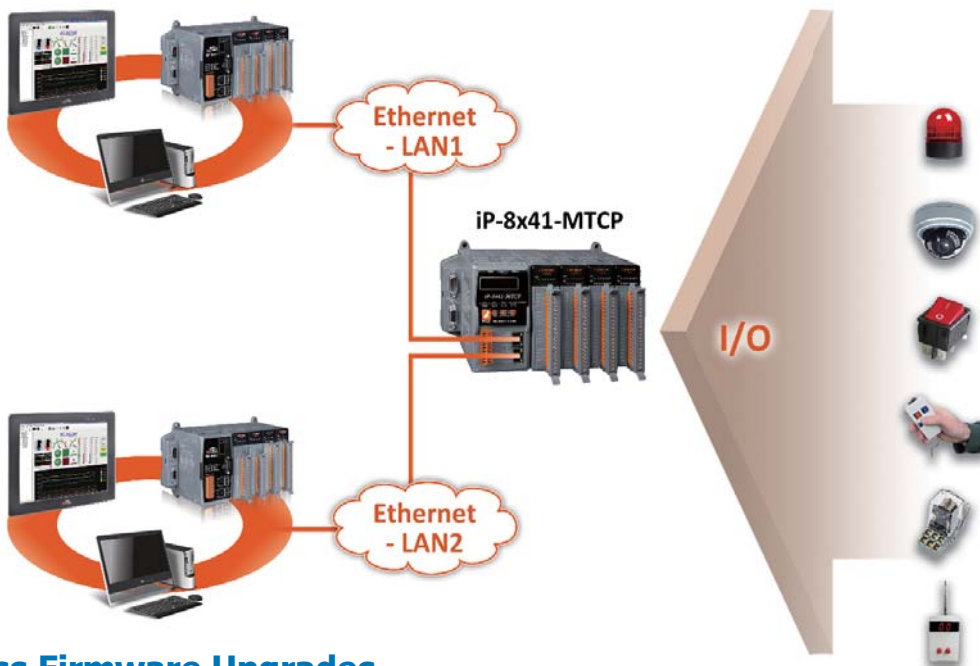

❖ Effortless Firmware Upgrades

Firmware can be easily upgraded to support the latest I-8KW or I-87KW module as it is released, ensuring compatibility with new features and enhancements without having to replace the entire system. This feature allows you to stay current with minimal investment and downtime.



Application: Intelligent Cooling Tower Status Monitoring

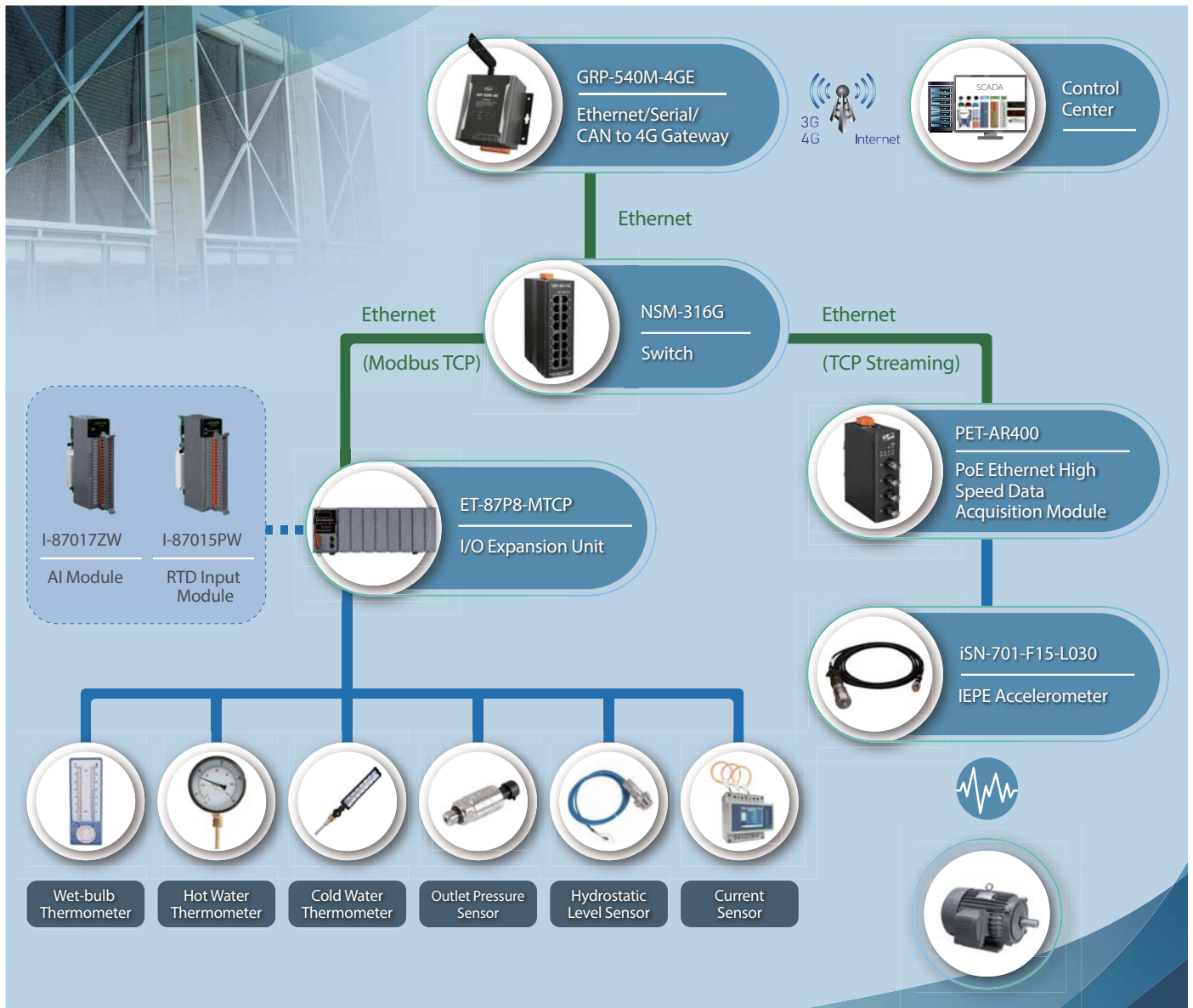

The client in this case is a chemical plant primarily engaged in the manufacturing, processing, and handling of chemicals. The plant is equipped with essential equipment such as boilers, distillation columns, reactors, and cooling towers to produce high-value-added products. Among these, the cooling tower plays a crucial role in heat dissipation during the production process. It utilizes water and cooling fans to drive hot air upwards, releasing it into the atmosphere to lower the system temperature. This technology is not only applicable to chemical plants but is also widely used in refineries, thermal power plants, and nuclear power plants.







Due to the large number of devices requiring monitoring in the field, the customer uses the ET-87P8-MTCP 8-slot intelligent Ethernet I/O expansion unit to simplify wiring. Paired with the I-87017ZW voltage/current input module, it captures the cooling tower's outlet pressure, hydrostatic level, and the cooling fan's motor current. Additionally, the I-87015PW RTD (Resistance Temperature Detector) input module collects the hot and cold water temperatures and wet-bulb temperature. The collected data is subsequently transmitted via wired/wireless Ethernet (Modbus TCP protocol) to the central control room to analyze the cooling efficiency of the water tower to achieve remote real-time monitoring of the cooling water tower system and improve overall operational efficiency.

Selection Guide:

Model	Ethernet	Protocol	I/O Slot	I-8KW series	I-87KW series	I/O Hot Swap	COM Port
 iP-8441-MTCP	2 (10/100 M) - Dual LAN - 2 IP Addresses	Modbus TCP	4	Yes	Yes	-	4
 iP-8841-MTCP			8				

Model	Ethernet	Protocol	I/O Slot	I-8KW series	I-87KW series	I/O Hot Swap	COM Port
 ET-8KP4-MTCP	2 (10/100 M) - Switch Ports - 1 IP Address	Modbus TCP	4	Yes	Yes	-	1
 ET-8KP8-MTCP			8				

Model	Ethernet	Protocol	I/O Slot	I-8KW series	I-87KW series	I/O Hot Swap	COM Port
 ET-87P4-MTCP	2 (10/100 M) - Switch Ports - 1 IP Address	Modbus TCP	4	-	Yes	Yes	1
 ET-87P8-MTCP			8				

Model	Ethernet	Protocol	I/O Slot	I-8KW series	I-87KW series	I/O Hot Swap	COM Port
 ET-87P4	2 (10/100 M) - Switch Ports - 1 IP Address	DCON	4	-	Yes	Yes	1
 ET-87P8			8				

5.2 I-8KW and I-87KW I/O Modules

The I-8KW modules use a parallel bus for high-speed operation, while the I-87KW modules use a serial bus and support a wider range of functions. Both module types are compatible with ICPDAS PAC systems and can be easily plugged into the backplane slots. ICPDAS offers more than 100 options for I/O, communication, GPS, counter, vibration, and temperature modules. Users can customize their systems by mixing and matching modules to suit specific applications.

Users can avoid unnecessary costs by selecting only the modules they need. Modules are easily replaced or upgraded, reducing downtime and maintenance costs. The centralized wiring and compact design optimize space, making it easy to deploy the system in tight spaces. The modular design, combined with the PAC's backplane and slot configurations, makes it an effective solution for creating flexible, cost-effective and easy-to-maintain systems.

1 I-8KW I/O Modules (Parallel Bus):

- High speed A/D: 100 k samples/second
- High speed D/A: 30 k (-10 ~ +10 V)
- High speed DI/DO: LED indicators for I/O status
- High speed stepping/Servo motion control
- High speed encoder modules
- High performance Counter/Frequency modules
- High speed multi-channel RS-232/422/485
- CAN bus communication modules

2 I-87KW I/O Modules (Serial Bus):

- RTD Input modules
- Thermocouple Input modules
- Strain Gauge Input modules
- VW Input modules
- High resolution multi-channel Analog Input
- Isolated multi-channel D/A modules
- DI modules support latch and counter function
- Counter/Frequency modules



3 Comparison Table of I-8KW and I-87KW Modules

Item	I-8KW Modules	I-87KW Modules
Communication Interface	Parallel bus	Serial bus
Protocol	-	DCON
DI with latched function	-	Y
DI with counter input	-	Y (100 Hz)
Power on value	-	Y
Safe value	-	Y
Programmable slew-rate for AO module	-	Y

4 Supporting I/O Module list of PAC and I/O expansion unit:

Item	I-8KW Modules	I-87KW Modules
XPAC-8000	Y	Y
WinPAC-8000	Y	Y
LinPAC-8000	Y	Y
iPAC-8000	Y	Y
ViewPAC	Y	Y
RU-87P1/2/4/8	-	Y
USB-87P1/2/4/8	-	Y
ET-87P4/8(-MTCP)	-	Y
ET-8KP4/8(-MTCP)	Y	Y
I-87K4/5/8/9	-	Y

5 Hot features

❖ Dual Watchdog with Power-on and Safe Values (I-87KW)

To ensure system reliability, stability, and continuous operation, this module incorporates a Dual Watchdog design. The hardware watchdog automatically resets the MCU if it detects a module freeze, preventing it from stopping working. This reset loads the AO/DO values according to user-defined power-on settings. The software watchdog monitors communication activity between the host controller and the module. If the watchdog timeout occurs, the module switches its outputs to predefined safe values to prevent incorrect operation.

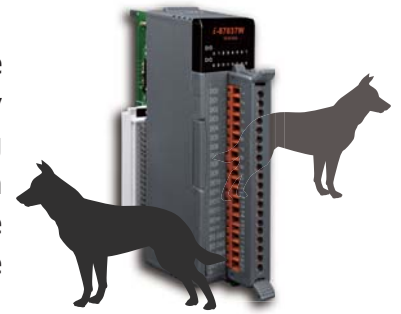

❖ Advanced DI Functions of I-87KW I/O Modules

DI channel is not only for reading digital input status but also provides several advanced functions.

● DI Latch Function

All DI channels provide Latch function to keep the high/low events in the internal registers of the module. In general, the host controller polls modules one by one to get all DI status. Because RS-485 is a low speed field bus, the polling will take time and probably miss a short duration signal. With the DI latch function, the short duration ($\geq 5\text{ms}$) signal will not be lost any more.

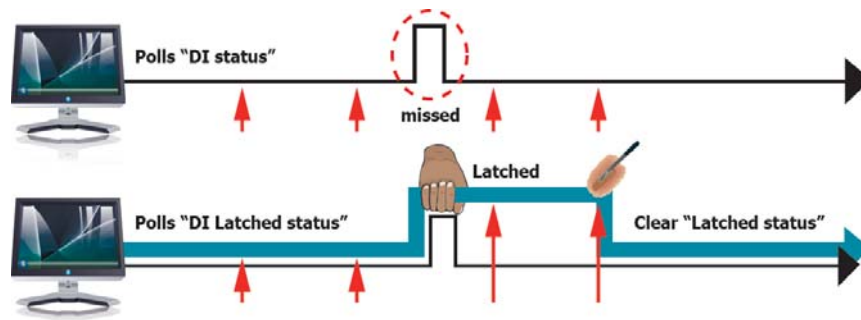

● 16-bit Counter

The DI module automatically counts the DI signal in the background. The signal under 100Hz can be detected and counted.



❖ Overvoltage Protection

Many of our analog input modules provide high overvoltage protection for the analog input channels. When user picks wrong line accidentally or high voltage spike is applied to the analog input terminals, the module will not be broken and can still get the correct readings. This feature improves the reliability, reduces maintenance frequency, and makes the whole system more robust.

❖ Open Wire Detection

Thermocouple, RTD, and thermistor sensors are essential in temperature control systems. However, without the ability to detect open wire conditions, these systems can become dangerous, potentially leading to severe damage or threats to life and property. If a sensor wire breaks and the controller is unaware of the fault, the system may continue heating the boiler, increasing the risk of fire or explosion. Our thermocouple, RTD, and thermistor modules include open wire detection, ensuring greater safety and preventing such critical hazards.

❖ Over-current Protection

Excessive current or voltage in the current loop can potentially damage the current measurement module. To prevent this, the protection has been upgraded to handle ± 120 VDC and ± 1000 mA. This enhancement ensures that the module remains safe even with high current or voltage, allowing the system to continue operating normally.

❖ Virtual Channel-to-Channel Isolation

The "R" and "Z" versions of the analog input modules provide ± 400 VDC virtual isolation between channels, reducing the effects of noise from nearby channels in industrial environments. This feature effectively reduces leakage current to as low as $1 \mu\text{A}$, resulting in negligible interference. Examples of these modules include the I-87017RW, I-87017ZW, I-87018RW, I-87018ZW, I-87019RW, and I-87019ZW.

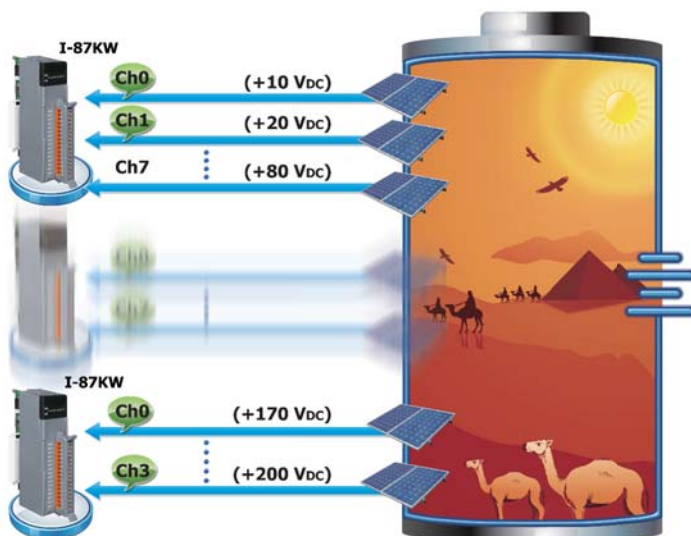

❖ Common Voltage Protection

The typical application is to monitor the charging status of the batteries in series. The voltage of each battery is +10 VDC so the first battery is +10 VDC, the second battery is +20 VDC etc. The differential voltage of the 20th battery is only +10 VDC between $\text{vin}+$ and vin- terminal, while the common voltage is up to 200 VDC. The inability to handle high common voltages will result in incorrect voltage readings. ICP DAS analog input modules are designed to support common voltages up to ± 200 VDC, making them ideal for industrial applications.

❖ ESD Protection

All I-8KW and I-87KW modules are designed to be immune to electrostatic discharge (ESD) by incorporating components that can clamp and withstand the high voltages specified in the IEC 61000-4-2 standard. These modules are robustly designed to resist noise, voltage spikes, and electrostatic interference. They successfully pass ± 4 KV ESD contact and ± 8 KV ESD air tests using a static electricity gun in our laboratory, ensuring reliable and stable operation in industrial environments.

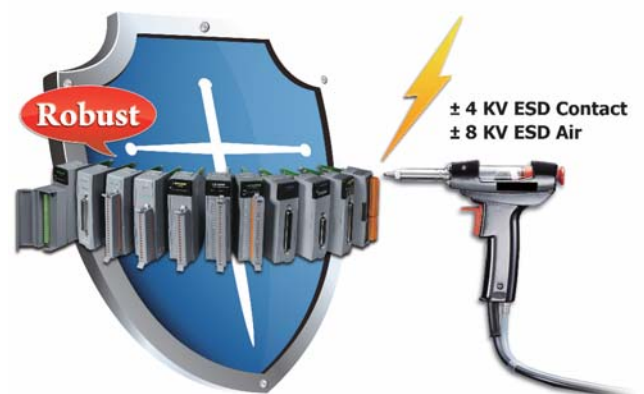

❖ 3000 VDC Isolation

The I-8KW and I-87KW modules feature 3000 VDC isolation between the field and internal logic circuits. This isolation protects the module's critical logic circuits from field noise and minimizes interference from adjacent slots, enhancing the module's robustness and reliability in industrial operations.

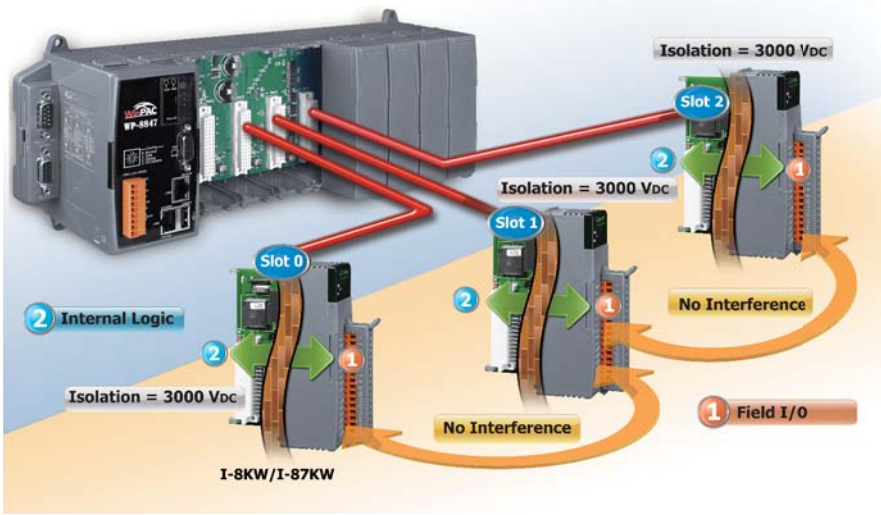

➔ High-speed Temperature Input Module

Model Name	Analog Input			
	Channels	Resolution	Sampling Rate	Sensor
I-8015W	8	16-bit	90 Hz/ch	2/3-Wire RTD (Pt100, Ni120, Cu50, Cu100)
I-8015W-12	12			
I-8018W/S	8	16-bit	100 Hz/ch	Thermocouple (J, K, T, E, R, S, B,N, C, L, M, LDIN43710)
I-8018W-16/S1	16			



I-8015W



I-8015W-12



I-8018W/S

= I-8018W + CN-1825 Daughter Board



I-8018W-16/S1

= I-8018W-16 + CN-1826 Daughter Board

➔ Analog Input Modules

Model Name	Analog Input				
	Channels	Resolution	Sampling Rate	Input Range	Sensor
I-87004W (*1)	4	12-bit	1 Hz	-	DS18B20 (-55 ~ +125°C)
I-87005W (*2)	8	16-bit	8 Hz	-	Thermistor
I-87013W	4	16-bit	10 Hz	-	RTD: Pt100, Pt1000, Cu50, Ni120
I-8014W	8/16	16-bit	250/45/25 kHz	±10 V, ±5 V, ±2.5 V, ±1.25 V, ±20 mA (with external 125 Ω resistor)	-
I-8014CW	8			±20 mA	-
I-87015W	7	16-bit	12 Hz	-	RTD: Pt100, Pt1000, Cu50, Cu100, Cu1000, Ni120
I-87015PW				-	
I-8017HW	8/16	14-bit	90/16 kHz	±10 V, ±5 V, ±2.5 V, ±1.25 V, ±20 mA (with external 125 Ω resistor)	-
I-8017HCW	8/16	14-bit	90/16 kHz	±10 V, ±5 V, ±2.5 V, ±1.25 V, ±20 mA (jumper)	-
I-8017DW					
I-87017W	8	16-bit	10/60 Hz	±10 V, ±5 V, ±1 V, ±0.5 V, ±150 mV, ±20 mA, 0 ~ 20 mA, 4 ~ 20 mA (with external 125 Ω resistor)	-
I-87017DW	8/16				
I-87017RW	8				
I-87017ZW	10/20	16-bit/ 12-bit	10/50 Hz	±10 V, ±5 V, ±1 V, ±0.5 V, ±150 mV, ±20 mA, 0 ~ 20 mA, 4 ~ 20 mA (jumper)	-
I-87017W-A5	8				
I-87017W-RMS	8	16-bit	10 Hz	0 ~ +10 Vrms, 0 ~ +5 Vrms, 0 ~ 1 Vrms, 0 ~ 500 mVrms, 0 ~ 150 mVrms	-
I-87017RCW	8	16-bit	10/60 Hz	0 ~ 20 mA, +4 ~ 20 mA, ±20 mA	-
I-87018W	8	16-bit	10 Hz	±2.5 V, ±1 V, ±500 mV, ±100 mV, ±50 mV, ±15 mV, ±20 mA (with external 125 Ω resistor)	Thermocouple (J, K, T, E, R, S, B, N, C, L, M)
I-87018RW					
I-87018PW-G/S	8				
I-87018ZW-G/S	10	±2.5 V, ±1 V, ±500 mV, ±100 mV, ±50 mV, ±15 mV, ±20 mA, 0 ~ 20 mA, 4 ~ 20 mA (with external 125 Ω resistor)			
I-87018ZW-G/S2					
I-87019RW	8	16-bit	8 Hz	±2.5 V, ±1 V, ±500 mV, ±100 mV, ±50 mV, ±20 mA (jumper)	
I-87019PW-G/S	8			±2.5 V, ±1 V, ±500 mV, ±100 mV, ±50 mV, ±15 mV, ±20 mA, 0 ~ 20 mA, 4 ~ 20 mA (jumper)	
I-87019ZW-G/S	10				
I-87019ZW-G/S2					



I-87018PW-G/S



I-87018ZW-G/S
= I-87018ZW + DB-1820



I-87019PW-G/S



I-87019ZW-G/S
= I-87019ZW + DB-1820



I-87018ZW-G/S2
= I-87018ZW + DN-1822
+ CA-252518D-1 (1.8 m)



I-87019ZW-G/S2
= I-87019ZW + DN-1822
+ CA-252518D-1 (1.8 m)

(*1): I-87004 has 4 ports, each port can link 20x DS18B20, total 80 sensors
(*2): I-87005 also includes 8 channel DO (Open Collector, sink, 700 mA)

➔ Analog Output Modules



Model Name	Analog Outputs					
	Channels	Resolution	Response Time	Output Range	Wiring Current Output	channel to channel Isolation
I-87022W	2	12-bit	10 ms per channel	0 ~ 10 V, ±10 V, 0 ~ 20 mA, 4 ~ 20 mA	Sink	Yes, 3 kv
I-87024W	4	14-bit		0 ~ 5 V, ±5 V, 0 ~ 10 V, ±10 V, 0 ~ 20 mA, 4 ~ 20 mA		-
I-87024RW		12-bit		0 ~ 20 mA, 4 ~ 20 mA	Source	
I-87024DW				16-bit		0 ~ 5 V, ±5 V, 0 ~ 10 V, ±10 V, 0 ~ 20 mA, 4 ~ 20 mA
I-87024CW		0 ~ 20 mA, 4 ~ 20 mA			Sink	Yes, 1 kv
I-87024UW	12-bit	0 ~ 20 mA, 4 ~ 20 mA		Source		Yes, 3 kv
I-87028CW	8	14-bit			0 ~ 5 V, ±5 V, 0 ~ 10 V, ±10 V, 0 ~ 20 mA, 4 ~ 20 mA	-
I-87028CDW		16-bit		0 ~ 10 V	-	
I-87028UW				12-bit		0 ~ 20 V
I-87028VW		14-bit		±10 V, ±20 mA	Sink	-
I-87028VW-20V			0 ~ 5 V, ±5 V, 0 ~ 10 V, ±10 V, 0 ~ 20 mA, 4 ~ 20 mA	Source		
I-8024W	4	16-bit	25 us per channel		±10 V, ±20 mA	Sink
I-8024UW	4	16-bit	105 us per channel	0 ~ 5 V, ±5 V, 0 ~ 10 V, ±10 V, 0 ~ 20 mA, 4 ~ 20 mA	Source	-
I-8028UW	8					

➔ Digital Input Modules

Model Name	Digital Input		
	Channels	Contact	ON Voltage Level
I-8040W	32	Wet	10 ~ 30 VDC
I-8040PW			19 ~ 30 VDC
I-8040PW-A1			3.5 ~ 30 VDC
I-8046W	16	Dry	Connect to GND
I-8048W (*)	8	Dry + Wet	4 ~ 30 VDC
I-8051W	16	Dry	Connect to GND
I-8052W	8	Wet	10 ~ 30 VDC
I-8053W	16		19 ~ 30 VDC
I-8053PW	16		3.5 ~ 30 VDC
I-8053W-A1	16		
I-8058W	8	AC, Differential	80 ~ 250 VAC
I-87040W	32	Wet	10 ~ 30 VDC
I-87040PW			19 ~ 30 VDC
I-87046W-G	16	Dry	Connect to GND
I-87051W-G			
I-87052W-G	8	AC, Differential	3.5 ~ 30 VDC
I-87058W-G			80 ~ 250 VAC
I-87059W-G			10 ~ 80 VAC
I-87053W-G			3.5 ~ 30 VDC
I-87053PW-G	16	Dry + Wet	19 ~ 30 VDC
I-87053W-A2			19 ~ 50 VDC
I-87053W-A5			68 ~ 150 VDC
I-87053W-AC1			10 ~ 80 VAC
I-87053W-E5			68 ~ 150 VDC

(*) : I-8048W is a 8-ch digital input interrupt module.

➔ Digital Output Modules

Model Name	Digital Output			
	Channels	Type	Sink/Source	Max. Load
I-8037W	16	Open Collector	Source (PNP)	100 mA
I-8041W	32		Sink (NPN)	100 mA
I-8041PW			Source (PNP)	100 mA
I-8041AW	16	Open Collector	Sink (NPN)	100 mA
I-8057W			700 mA	
I-8057PW			700 mA	
I-87037W	16	Open Emitter	Source (PNP)	700 mA
I-87041W	32	Open Collector	Sink (NPN)	100 mA
I-87041PW				200 mA
I-87057W				100 mA
I-87057PW				700 mA

Digital Modules

Model Name	Digital Input			Digital Output			
	Channels	Contact	ON Voltage Level	Channels	Type	Sink/Source	Max. Load
I-8042W	16	Wet	10 ~ 30 VDC	16	Open Collector	Sink (NPN)	100 mA
I-8050W (*)							100 mA
I-8054W							700 mA
I-8055W	8	Dry	Connect to GND	8			100 mA
I-87042W	16	Wet	3.5 ~ 30 VDC	16	Open Collector	Sink (NPN)	100 mA
I-87054W							700 mA
I-87055W	8	Dry	Connect to GND	8			100 mA

(*) : I-8050W is a 16-ch universal digital input/output module.

I-8017DW, I-87017DW
8/16 Channels
AI Module

**I-87024DW,
I-87028CDW,**
4/8 Channels AO
Module

I-8040W, I-87040W Series,
32-ch Isolated DI Module

I-8041W, I-87041W Series,
32-ch Isolated DO Module

**I-8042W, I-87042W Series, 16-ch
Isolated DI & 16-ch Isolated DO Module**

DN-37-381-A
Female DB37 to Screw Terminal Board
(Pitch= 3.81 mm) with DIN-rail Mounting
Dimensions: 99 mm × 81 mm
Include: CA-3710A (DB37 Male to Female
Cable, 90°, 1 M)

DN-37-A
Female DB37 to Screw Terminal Board
(Pitch= 5.08 mm) with DIN-rail Mounting
Dimensions: 144 mm × 72 mm
Include: CA-3710A (DB37 Male to Female
Cable, 90°, 1 M)

DN-8K32R CR
32-channel Relay (Form A, 3A) Output
Board (Pitch= 3.81 mm) with DIN-rail
Mounting
Dimensions: 174 mm × 118 mm
Include: CA-3705A
(DB37 Male to Female Cable, 90°, 0.5 M)

DN-8K16P16R
16-channel digital input terminal and
16-channel relay output board
(Pitch= 3.81 mm) with DIN-rail Mounting
Dimensions: 174 mm × 118 mm
Include: CA-3705A (DB37 Male to Female
Cable, 90°, 0.5 M)

Multi-Function/Strain Gauge Modules



Model Name	Analog Inputs		Analog Outputs	Digital Inputs	Digital Outputs
	Channels	Sampling Rate			
I-87016W	2 (Strain Gauges) (Full-bridge, Half-bridge, Quarter-bridge)	10 Hz	2 (Voltage, Current)	2 (Wet, Sink)	2 (Open Collector, Sink)
I-87026PW	6 (Voltage, Current)	10/60 Hz			
I-8026W		9 kHz			

Relay Modules



Model Name	Channels	Type	Contact	Load Current
I-8060W	6	Power Relay	Form C	0.5 A @ 125 VAC, 0.25 A @ 250 VAC, 2 A @ 30 VDC
I-8063W (*)	4	Power Relay	Form C	5 A(NO)/3 A(NC) @ 30 VDC 5 A(NO)/3 A(NC) @ 277 VAC
I-8064W	8	Power Relay	Form A	5 A @ 250 VAC, 5A @ 30 VDC
I-8068W	8	Power Relay	Form A x 4 Form C x 4	Form A: 5 A @ 250 VAC/28 VDC Form C: 5 A (NO) @ 277 VAC/30 VDC 3 A (NC) @ 277 VAC/30 VDC
I-8069W	8	PhotoMOS	Form A	1 A @ 60 VDC
I-87061W	16	Power Relay	Form A	10 A @ 250 VAC/24 VDC
I-87061PW				3 A @ 250 VAC/24 VDC
I-87063W (*)	4	Power Relay	Form C	5 A (NO)/3 A (NC) @ 30 VDC 5 A (NO)/3 A (NC) @ 277 VAC
I-87064W	8	Power Relay	Form A	5.0 A @ 250 VAC/30 VDC
I-87065W	8	AC SSR	Form A	1.0 A @ 265 VAC
I-87066W	8	DC SSR	Form A	1.0 A @ 30 VDC
I-87068W	8	PhotoMOS	Form A x 4 Form C x 4	Form A: 8 A @ 250 VAC/28 VDC Form C: 5 A (NO) @ 277 VAC/30 VDC 3 A (NC) @ 277 VAC/30 VDC
I-87068W-2A		Signal Relay		Form A: 2 A @ 30 VDC 0.24 A @ 220 VDC 0.25 A @ 250 VAC Form C: 2 A @ 30 VDC 0.24 A @ 220 VDC 0.25 A @ 250 VAC
I-87069W	8	PhotoMOS	Form A	0.13 A, 350 V Max. at DC/AC
I-87069PW				1.0 A, 80 V Max. at DC/AC

(*): I-8063W and I-87063W also have 4 DI (Wet contact, sink and source)

Counter/Frequency/PWM Modules



Model Name	Counter/Frequency Input					PWM Output	
	Channels	Counter	Signal	Speed	Frequency Accuracy	Channels	Type
I-87082W	2	32-bit	Up	100 kHz	1 Hz	2	Open Collector
I-8084W	4/8	32-bit	Up, CW/CCW, A/B, Pulse/Dir	250 kHz	+/-0.025 %	-	-
I-87084W					+/-0.02 %	-	-
I-8088W	-	-	-	-	-	8	PWM Duty: 0.1 ~ 99.9% Freq: 1 ~ 500 KHz
I-87088W	8	32-bit	Up	1 MHz	-		

The diagram illustrates the DN-8P8C/S module and its connections. On the left, a fan and light bulb are shown with a blue arrow pointing to the module, labeled '+3.5 to +50 V PWM Output'. Below them, a motor is shown with a green arrow pointing to the module, labeled '+3.5 to +50 V Counter Input'. The module itself is shown with connectors CN1, CN2, CON1, and DB-8820. A cable CA-2520D is also shown. To the right, a red plus sign indicates compatibility with modules I-87088W, I-8088W, CAN-2088C, and CAN-2088D.



USB I/O Products

- 6.1 USB-2000 and USB-2200 I/O Modules - - - - - P 104
- 6.2 USB-4000 I/O Modules - - - - - P 108
- 6.3 USB-87Pn I/O Expansion Units - - - - - P 110

USB I/O Products

USB technology has become essential in modern computers and laptops, providing easy connections for both data and power. The ICP DAS USB I/O modules are designed to be compact, portable, and plug-and-play, providing a variety of I/O functions that make it easy to set up projects for various applications. These modules are ideal for building PC-based control systems, conducting laboratory research, or performing tests.

Features:

❖ LED Indicators for Easy Diagnostics

LED indicators provide instant visual feedback on power and I/O status, as well as error identification, allowing users to quickly determine if the device is functioning properly. This feature greatly simplifies and speeds up the troubleshooting process.

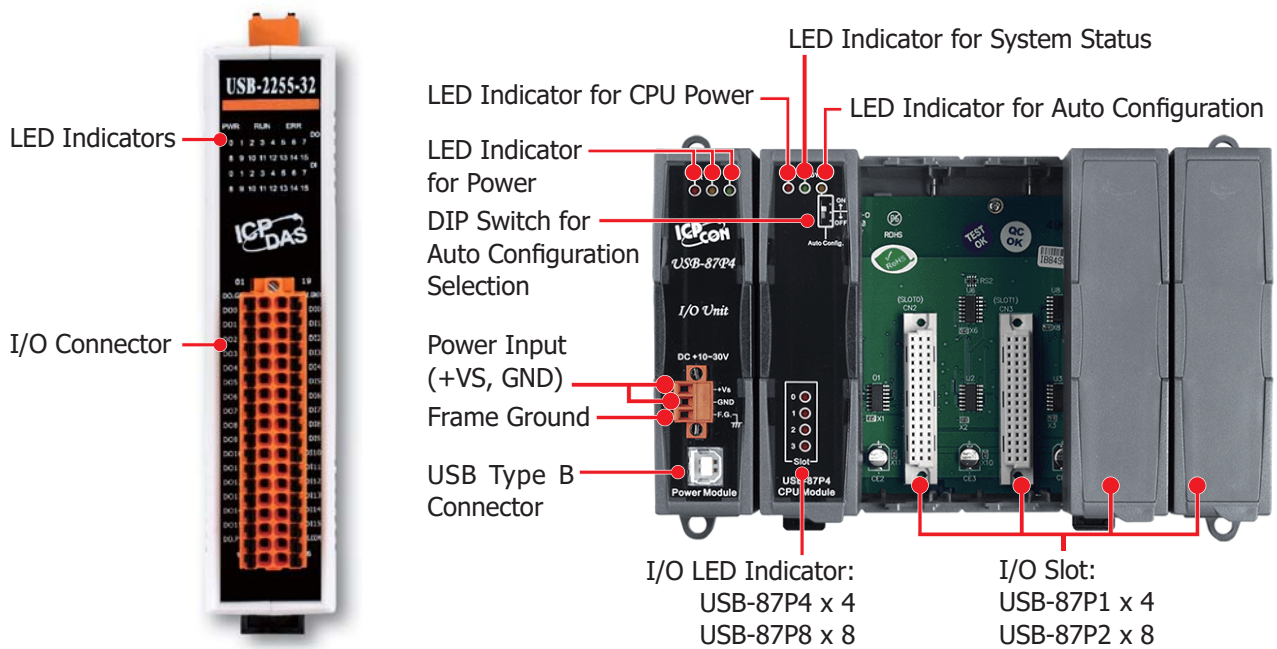

❖ Lockable USB Cable for Stable Connection

Our lockable USB cable provides a stable connection in environments where cables can be accidentally pulled or bumped. It minimizes interruptions caused by accidental disconnections, increasing productivity.

Ferrite cores in USB cables reduce electromagnetic interference (EMI), protect connected devices from voltage spikes, and ensure stable data transfer in noisy environments.







		
<p>CA-USB-AC2-L018 Cable within cores for USB-2200</p>	<p>CA-USB15 Cable within cores for USB-2000 and USB-87Pn</p>	<p>CA-USB-AM1-L015 Cable within cores for USB-4000</p>

❖ Dual Watchdog with Power-on and Safe Values

To ensure system reliability, stability, and continuous operation, this module incorporates a Dual Watchdog design. The hardware watchdog automatically resets the MCU if it detects a module freeze, preventing it from stopping working. This reset loads the AO/DO values according to user-defined power-on settings. The software watchdog monitors communication activity between the host controller and the module. If the watchdog timeout occurs, the module switches its outputs to predefined safe values to prevent incorrect operation.



Product Lines Comparison:

Product Line	USB-2200	USB-2000	USB-4000	USB-87Pn
Pictures				
Page	P.104	P.104	P.108	P.110
USB Connector	Type C	Type B	Micro	Type B
Daisy-Chain Wiring	Yes (USB)	-	-	-
Lockable Cable	Yes	Yes	Yes	Yes
Board ID	Yes	Yes	Yes	-
Protocol	Proprietary	Proprietary	Modbus RTU	DCON (ASCII format)
Driver	Built-in USB Mass Storage driver for Windows / Linux	Built-in USB HID driver for Windows / Linux	Virtual COM driver for Windows 10	Virtual COM driver for Windows, Linux
Power Supply	+10 ~ +30 VDC (Redundant Power)	USB Port	USB Port	+10 ~ +30 VDC
Redundant Power	Yes	-	-	-
Speed	480 Mbps (USB 2.0 High-Speed)	12 Mbps (USB 2.0 Full-Speed)	12 Mbps (USB 2.0 Full-Speed)	12 Mbps (USB 2.0 Full-Speed)
I/O Slots	-	-	-	1 / 2 / 4 / 8
Dimensions (Units: mm)	31 x 166 x 129 56 x 180 x 144	33 x 110 x 96 31 x 147 x 126	113 x 169 x 29 113 x 169 x 54	64 x 120 x 110 (Min.) 312 x 132 x 111 (Max.)
Utility	USB I/O Utility	USB I/O Utility	USB-4018H Utility	DCON Utility Pro
SDK Sample	VB, C++, C#.Net, VB.Net, LabVIEW, Python, Linux driver	VB, C++, C#.Net, VB.Net, LabVIEW, Python, Linux driver	Modbus SDK, VB, C++, C#.Net, VB.Net, LabVIEW, Python, InduSoft, Linux, OPC server	VB, C++, C#.Net, VB.Net, LabVIEW, Python, InduSoft, Linux, OPC server

6.1 USB-2000 and USB-2200 I/O Modules

The USB-2000 I/O modules can be powered through a USB port, eliminating the need for an external power supply. A single USB cable provides both data transfer and power, simplifying wiring and installation. These modules provide a variety of digital and analog I/O functions, with all digital inputs supporting selectable sink or source signals and can also operate as 32-bit counters. Analog inputs provide high-speed data acquisition up to 10 kS/s. With their versatile I/O capabilities, these modules are ideal for automation systems and real-time applications such as vibration and current measurement.

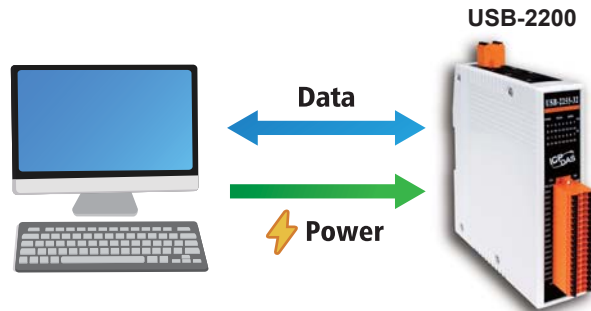

Features:

❖ High Channel Count for Cost Reduction

Integrating up to 64 digital I/O channels in a single module, this product optimizes space and reduces costs by reducing the number of modules required. It improves system performance by facilitating communication with fewer modules and allowing centralized control of I/O operations. The high channel count design also results in a lower price per channel.

❖ Board ID for Easy Device Identification

The USB-2000 and USB-2200 modules are equipped with a built-in rotary switch (default value 0) that allows you to set a unique board ID for each module. This is particularly useful when multiple modules are used in the same system, as it helps to identify the device number of each module. In addition, no software changes are required when replacing a module with another of the same model and board ID.



❖ Daisy-Chain USB Wiring for Easy Installation (USB-2200)

The USB-2200 modules have a built-in 2-port USB 2.0 hub that supports daisy-chain topologies, allowing multiple modules to be integrated into a single system while freeing up computer USB ports. This feature simplifies cabling and significantly reduces the cost of USB hubs. However, because USB 2.0 provides only 500mA of power, an external power supply is required when multiple modules are daisy-chained.

Note: The USB host can support up to five levels of hubs.

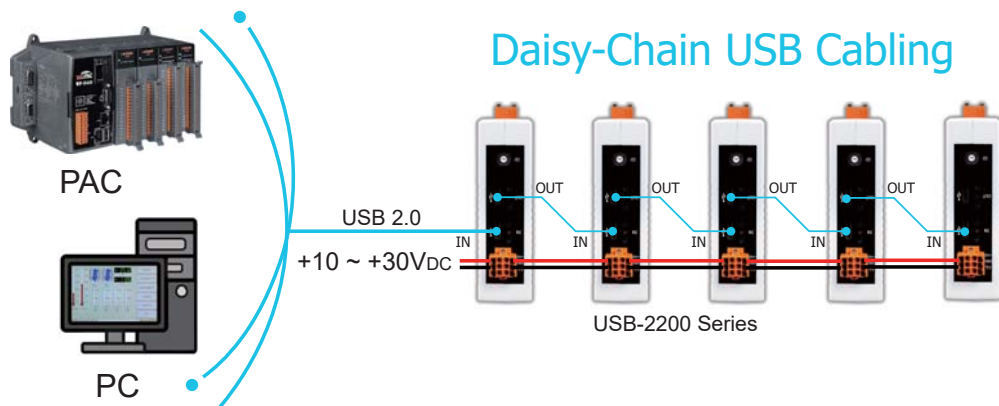

❖ Redundant Power Input for Increased Reliability (USB-2200)

The USB-2200 modules support two power inputs with a voltage range of +10 to +30 VDC for enhanced redundancy. If one power supply fails, the other will seamlessly take over. The modules can function properly with only one power source and can also be powered from a USB 2.0 port when not using the daisy-chain feature.

❖ SDK and Demo Programs

We provide an API library and demo source code for Windows and Linux users to easily and quickly develop programs that access these USB I/O modules using various tools (VB, C++, C#.Net, VB.Net, LabVIEW, Python, Linux driver).

❖ USB I/O Utility for Easy Configuration and Test

The software supports all ICP DAS USB I/O modules, simplifies I/O control and testing, and allows for immediate data acquisition without programming.

- > Automatically Scans All I/O Modules
- > Quickly Configures and Tests I/O Modules
- > Completely and Accurately Logs I/O Data for Analysis

❖ Plug-and-Play for Windows and Linux Systems



These modules support the built-in USB HID or Mass Storage driver for Windows and Linux, making the module plug-and-play without the need to install additional drivers.

More Features

- Selectable Dry/Wet Contact Inputs via Wires
- All Digital Inputs Act as 32-bit Counters (500 Hz)
- 16-bit High Resolution ADC for Accurate Measurement
- Overvoltage protection up to 240 Vrms
- LED Indicators for Easy Diagnostics
- Dual Watchdog with Power-On and Safe Values
- USB Powered Directly (No External Power Supply)
- Rugged Design with ± 4 kV ESD Protection
- Up to 3750 VDC Field-to-Logic High Voltage Isolation
- Wide Operating Temperature Range for Industrial Use
- Wide Power Input Range for Stable Operation
- USB 2.0 Full-Speed Compliant
- Support 32/64-bit Windows 7/8/10/11 and Linux
- Easy Firmware Update via USB

Selection Guide:

☑ USB Analog I/O

Model Name	Analog Input						Analog Output		
	Channels	Resolution	Type	Range	Isolation	Sampling Rate	Channels	Resolution	Range
 USB-2019	8	16-bit	Voltage, Current	± 15 mV, ± 50 mV, ± 100 mV, ± 150 mV, ± 500 mV, ± 20 mA, $0 \sim +20$ mA, $+4 \sim +20$ mA, ± 1 V, ± 2.5 V, ± 5 V, ± 10 V. Thermocouple: J, K, T, E, R, S, B, N, C, L, M, L(DIN43710)	3000 VDC	10 Hz	-	-	-
 USB-AR400	4	24-bit	IEPE	± 1.25 V, ± 2.5 V, ± 5 V, ± 10 V	-	256k Hz (per channel)	-	-	-

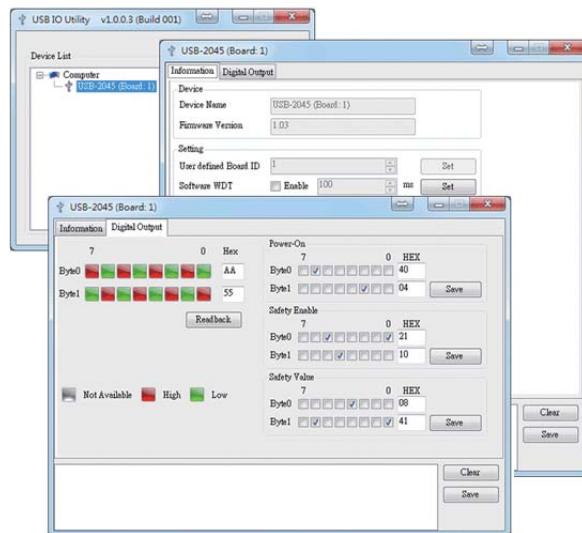
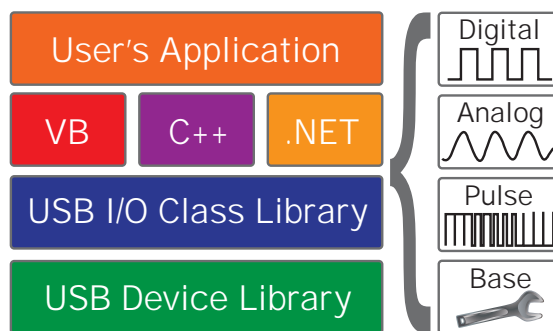







 USB Multifunction I/O

Model Name	Analog Input			Analog Output		Digital Input		Digital Output		
	Channels	Resolution	Sampling Rate	Channels	Resolution	Channels	Type	Channels	Type	Rating
 USB-2026	5	14/12	10/200 Hz	2	12	2	Dry: Source	2	OC, Sink	700 mA









 USB Digital I/O

Model Name	Digital Input		Digital Output		
	Channels	Type	Channels	Type	Rating
 USB-2045	-	Dry: Source	16	Open Collector, Sink	700 mA/Channel
 USB-2045-32	-	Dry: Source	32	Open Collector, Sink	500 mA/Channel
 USB-2051	16	Dry: Source Wet: Sink/Source	-	-	-
 USB-2051-32	32	Dry: Source Wet: Sink/Source	-	-	-
 USB-2055	8	Dry: Source Wet: Sink/Source	8	Open Collector, Sink	700 mA/Channel
 USB-2055-32	16	Dry: Source Wet: Sink/Source	16	Open Collector, Sink	600 mA/Channel
 USB-2060	6	Dry: Source Wet: Sink/Source	6	Power Relay, Form A (SPST N.O)	5 A
 USB-2064	-	-	8	Form A (SPST N.O.)	5 A
 USB-2064-16	-	-	16	Form A (SPST N.O.)	3 A
 USB-2068-18	10	Dry: Source Wet: Sink/Source	8	Signal Relay, Form C (DPDT)	2 A @ 30 VDC 0.24 A @ 220 VAC



 Daisy-Chained USB Digital I/O

Model Name	Digital Input		Digital Output		
	Channels	Type	Channels	Type	Rating
 USB-2245U-32	-	-	32	Push-Pull, Sink/Source (NPN/PNP)	50 VDC @ 600 mA/Channel
 USB-2245U-64	-	-	64	Push-Pull, Sink/Source (NPN/PNP)	50 VDC @ 500 mA/Channel
 USB-2251-32	32	Dry: Source Wet: Sink/Source	-	-	-
 USB-2251-64	64		-	-	-
 USB-2255-32	16	Dry: Source Wet: Sink/Source	16	Open Collector, Sink	600 mA/Channel
 USB-2255-64	32		32	Open Collector, Sink	500 mA/Channel

Daisy-Chained USB Relay Output

Model Name		Digital Input		Digital Output		
		Channels	Type	Channels	Type	Rating
	USB-2261-16	-	-	16	Form A (SPST N.O)	250 VAC @ 3 A /Channel 24 VDC @ 3 A /Channel
	USB-2261-32	-	-	32		
	USB-2261A-16	-	-	16	AC-SSR	265VDC @ 1 A /Channel
	USB-2261A-32	-	-	32		
	USB-2261B-16	-	-	16	DC-SSR	30 VDC @ 1A /Channel
	USB-2261B-32	-	-	32		
	USB-2261C-16	-	-	16	PhotoMOS Relay	80 VDC/VAC @ 1 A /Channel
	USB-2261C-32	-	-	32		
	USB-2260-24	16	Dry: Source Wet: Sink/Source	8	Form A (SPST N.O)	250 VAC @ 3 A /Channel 24 VDC @ 3 A /Channel
	USB-2260-48	32		16		
	USB-2260A-24	16		8	AC-SSR	265 VAC @ 1A /Channel
	USB-2260A-48	32		16		
	USB-2260B-24	16		8	DC-SSR	30 VDC @ 1A /Channel
	USB-2260B-48	32		16		
	USB-2260C-24	16		8	PhotoMOS Relay	80 VDC/VAC @ 1 A /Channel
	USB-2260C-48	32		16		

Daisy-Chained USB Analog I/O

Model Name		Analog Input				Analog Output			
		Channels	Resolution	Type	Range	Sampling Rate	Channels	Resolution	Range
	USB-2217	8	16-bit	Voltage Current	±2.5 V, ±5 V, ±10 V, 0 ~ +20 mA, ±20 mA, +4 ~ +20 mA	10k Hz (per channel)	-	-	-
	USB-2217H	8	16-bit	Voltage Current		200k Hz (per channel)	-	-	-
	USB-2224	-	-	-	-	-	4	16-bit	±5 V, ±10 V, ±20 mA, 0 ~ +20 mA, +4 ~ +20 mA

USB Pulse I/O

Model Name		Interface	Pulse Input		
			Channels	Input Frequency	Isolation
	USB-2084	USB 2.0	4 Up/Down (CW/CCW) 4 Dir/Pulse (Bi-direction) 4 A/B Phase (Quadrant Counting) 8 Up Counter, Frequency	TTL: 500 KHz maximum Isolated: 250 KHz maximum	2500 VDC

6.2 USB-4000 I/O Modules

The USB-4000 series high-speed USB I/O modules support the Modbus RTU protocol and provide a virtual COM port interface over USB. Both Modbus RTU and COM port are widely used in industrial automation systems, enabling seamless integration with various SCADA and HMI systems. In addition, the USB-4018H utility allows users to easily configure and test the modules without any coding. This versatility makes it suitable for a wide range of applications, including measurement and automated test systems.

Features:

❖ High Channel Count for Cost Reduction

Integrating up to 16 analog inputs in a single module, this product optimizes space and reduces costs by reducing the number of modules required. It improves system performance by facilitating communication with fewer modules. The high channel count design also results in a lower price per channel, allows for centralized cabling, and is easy to maintain.

❖ Support Various Thermocouple Types (USB-4018H series)

Designed specifically for high-speed thermocouple measurements, the USB-4018H series supports a wide range of thermocouple types, including J, K, T, E, R, S, B, N, C, L, M, and L DIN 43710. This module provides highly accurate measurements with automatic cold junction compensation for each channel. This module supports standard thermocouple connectors, allowing for easy integration and quick connections. This ensures stable and accurate temperature readings.

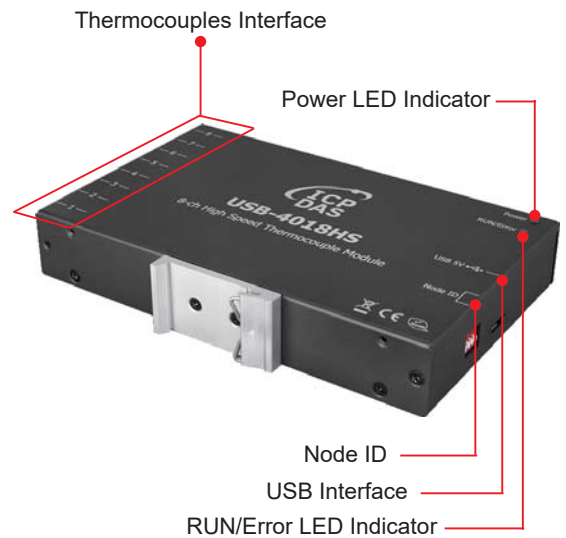
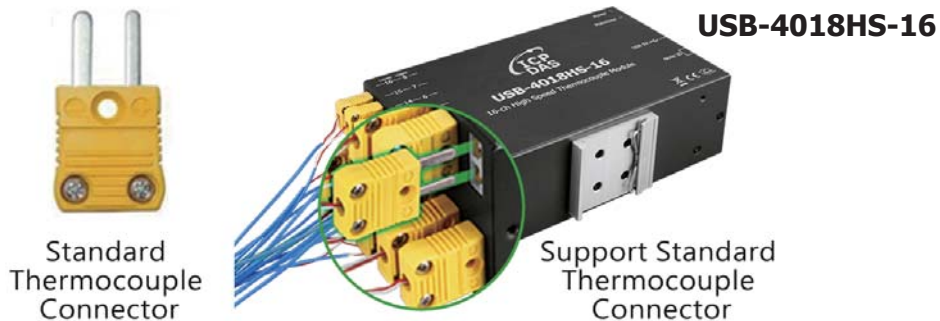

❖ Node ID (Board ID) for Easy Device Identification

The default setting for Node ID switches 1 through 4 is off (value 0). For systems with multiple USB-4018H modules, configure the DIP switches to assign a unique Node ID (from 0 to 15) to each module. If you replace a module with the same model and Node ID, you don't need to reinstall the driver, the COM port number remains the same, and no software changes are required.

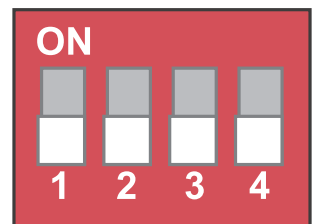

❖ 3000 VDC Field-to-Logic High Voltage Isolation

With built-in 3000 VDC field-to-logic isolation that shields the internal logic from external noise and improves the reliability of the system.

❖ Various Mountings for Stable and Easy Installation

Support DIN-Rail, Combine, Upright and Lay Flat wall mounts. These mounts provide stable installation, easy maintenance, and are ideal for space-constrained applications.



DIN-Rail Mounting

USB-4018HS + Standard accessories
USB-4018HS-16 + Standard accessories



Combine-Wall Mounting

USB-4018HS x 2 + ASO-0057



Upright - Wall Mounting

USB-4018HS + ASO-0015
USB-4018HS-16 + ASO-0023



Lay Flat - Wall Mounting



USB-4018HS + ASO-0059
USB-4018HS-16 + ASO-0059

More Features

- 8/16 Channel Analog Inputs
- 16-bit High Resolution ADC for Accurate Measurement
- High Speed Thermocouple Measurement
- USB 2.0 Full-Speed (12 Mbps)
- USB Powered Directly (No External Power Supply)
- LED Indicators for Easy Diagnostics
- Wide Operating Temperature (-25°C to +75°C)
- Software Utility for Easy Configuration and Test
- eLogger HMI for Building Small Data Logger Applications
- OPC Server for Seamless SCADA/HMI Integration
- Virtual COM Driver for 32/64-bit Windows 7/10
- Modbus RTU Protocol for Easy Application Integration
- nModbus SDK for Modbus Programs Development

Selection Guide:

✓ USB Analog I/O

Model Name	Interface	Analog Input			
		Channels	Resolution	Input Type	Isolation
 USB-4018	USB 2.0	8	16-bit	Thermocouple : J, K, T, E, R, S, B, N, C, L, M, L(DIN43710)	3000 VDC
 USB-4018HS-16	USB 2.0	16			

6.3 USB-87Pn I/O Expansion Units

The USB-87Pn expansion units feature a multi-slot backplane for flexible I/O configurations using high-profile I-87KW modules, supporting analog I/O, digital I/O, counters, and more. These units include easy-to-use features such as hot-swap capability, auto-configuration, and LED indicators for diagnostics. These I-87KW modules support dual watchdog with programmable power-on and safe values for increased reliability. We offer a variety of SDKs and demos, including DLLs, LabVIEW drivers, InduSoft drivers, Linux drivers, and an OPC server, for easy integration of the I-87KW I/O modules into industrial automation systems. See Chapter 5.2 for details on the I-87KW I/O modules.



Features:

❖ Hot-Swap and Auto-Configuration for Easy Maintenance

The USB-87Pn expansion unit allows I-87KW I/O modules to be replaced or added without powering down the entire system. I-87KW modules can be pre-configured and the settings can be stored in the non-volatile memory of the USB-87Pn. When the USB-87Pn is powered on or an I-87KW module is plugged in, it automatically checks and restores the configurations for each I-87KW module connected to it. The Auto-Configuration allows for easy maintenance without the need for a PC or laptop.

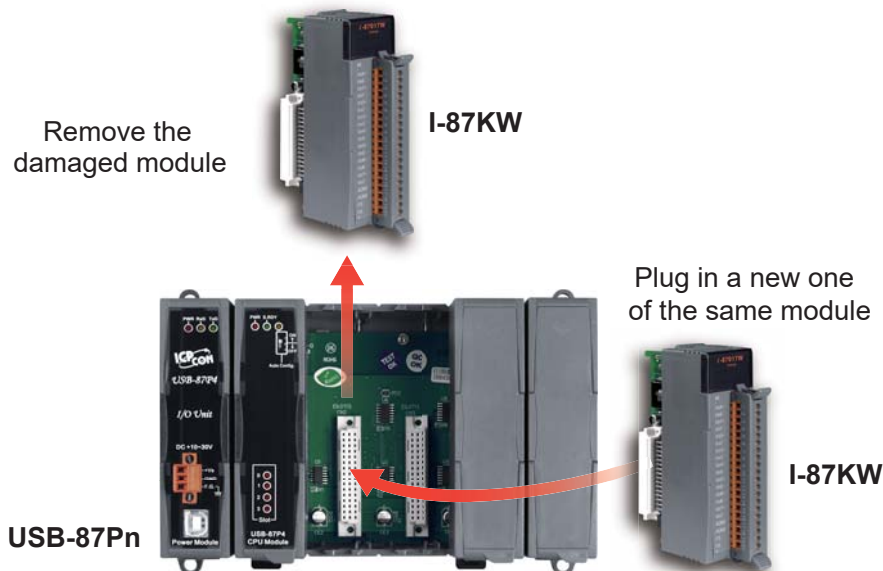

❖ Easy Duplicate System

With the DCON Utility Pro you can save the settings of the I-87KW modules in a configuration file on your PC. This file can later be loaded and written to another USB-87Pn unit, allowing easy and quick duplication of multiple USB-87Pn units with the same configuration. In addition, the configuration file serves as a valuable backup or reference for your projects.



❖ Virtual COM Driver for Easy Integration

USB-87Pn units support virtual COM port interface over USB communication. The COM port is widely used in industrial automation, making these units easy to integrate into systems.

❖ DCON Protocol for Easy to Use

DCON is a simple command/response protocol used to communicate with I-87KW modules plugged into a USB-87Pn unit. The protocol is written in an easy-to-use ASCII format.

More Features

- Multiple Slots for Flexible I/O Configurations Using I-87KW Modules
- USB Port Built-in 3000 VDC Isolation Protection
- Wide Range Power Input (+10 ~ +30 VDC)
- Wide Operating Temperature (-25°C to +75°C)
- DIN-Rail and Wall Mountings for Stable and Easy Installation
- Rugged Design with ± 4 kV ESD Protection
- DCON Utility Pro for Easy Test, Configuration and Backup Settings
- eLogger HMI for Building Small Data Logger Applications
- OPC Server for Easy SCADA/HMI Integration
- DLL Library and Demo Programs for Easy Development
- Support LabVIEW, Python, InduSoft and Linux system

Selection Guide:



Model Name	Interface	Description
 USB-87P1 USB-87P2 USB-87P4 USB-87P8	USB 2.0	I/O Expansion Unit with 1/2/4/8 slots, support I-87KW series I/O modules



Related Products

- 7.1 EtherCAT I/O Modules - - - - - P 113
- 7.2 Fieldbus I/O Products - - - - - P 117
 - 7.2.1 CANopen Modules - - - - - P 118
 - 7.2.2 DeviceNet Modules - - - - - P 122
 - 7.2.3 PROFIBUS Modules - - - - - P 125
 - 7.2.4 PROFINET Modules - - - - - P 128
 - 7.2.5 EtherNet/IP Modules - - - - - P 130
 - 7.2.6 BACnet Modules - - - - - P 132
- 7.3 Wireless I/O Products - - - - - P 133
 - 7.3.1 Wi-Fi Modules - - - - - P 134
 - 7.3.2 ZigBee Modules - - - - - P 137
 - 7.3.3 RF Modules - - - - - P 141

7.1 EtherCAT I/O Modules

EtherCAT is a high-speed, real-time industrial communication protocol designed for precise synchronization and efficient data transmission. It overcomes the limitations of traditional communication modules, such as lower performance and complex Local Bus wiring. With excellent scalability and flexibility, it supports various digital and analog signals, making it ideal for factory automation, machine control, and smart manufacturing. By simplifying wiring and enhancing system stability, EtherCAT reduces installation time and costs while easily integrating diverse control and monitoring devices, providing a reliable solution for high-performance industrial automation.

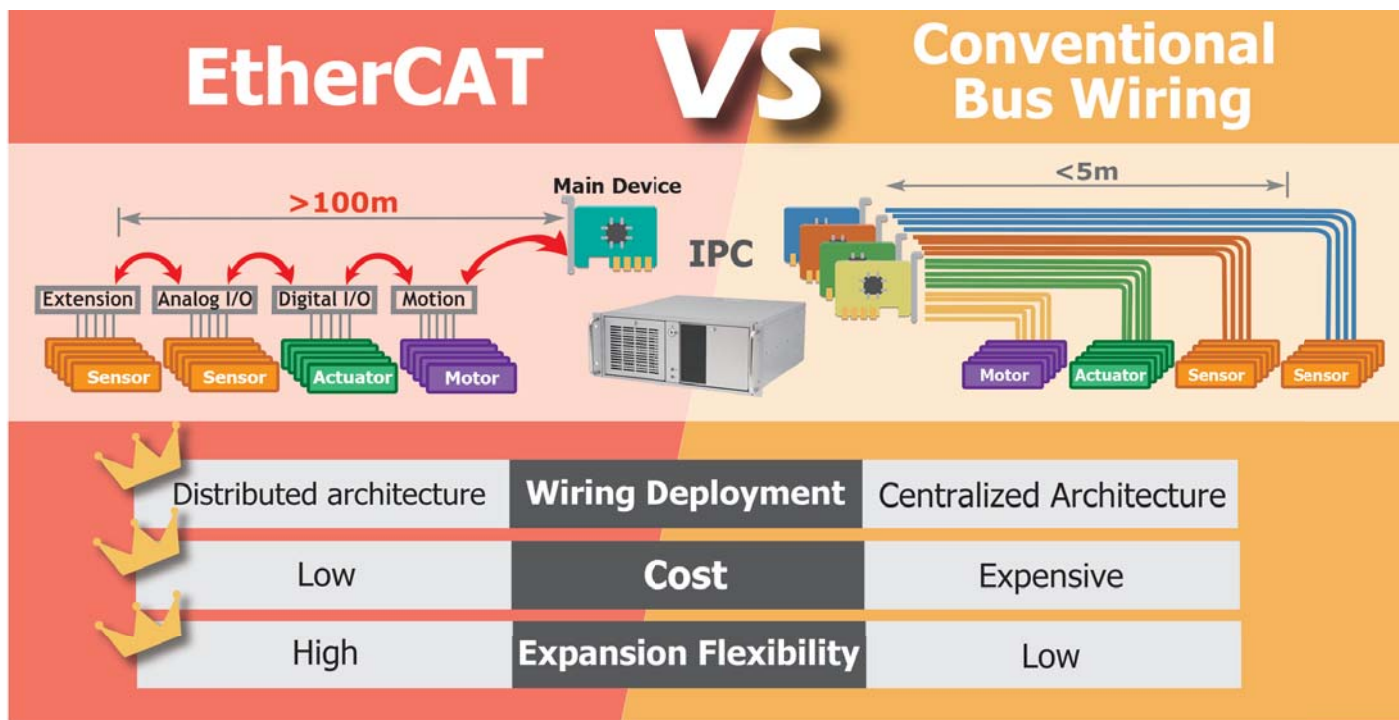





- High-Speed Performance:**
 EtherCAT offers extremely fast data processing capabilities, achieving control cycles as short as 100 μ s, meeting the demands of real-time applications.
- Efficient and Multi-Channel Processing:**
 It can read and write data from multiple slave devices simultaneously. For example, 2000 channels can be read and written within 50 μ s.
- Synchronization Accuracy:**
 Using Distributed Clocks technology, EtherCAT achieves time synchronization within less than 1 μ s, making it ideal for motion control and precision automation applications.

- Flexible Topology:**
 Supports various topologies, including linear, star, ring, and tree configurations, offering more flexibility in system design.
- Easy Wiring and Setup:**
 Based on standard Ethernet hardware, no special network equipment or IP address configuration is needed, significantly reducing setup and maintenance costs.
- Strong Compatibility:**
 Supports interoperability with devices from multiple manufacturers, making it easier to integrate existing systems and expand functionality.

ICP DAS offers a diverse range of EtherCAT modules, including the economical and stable ECAT-2000 series, the efficient and reliable EC2 distributed modules, the EC1 plug-in modules that save wiring and installation time, and the compact and highly flexible EC4 slim modules with expandability, catering to a wide range of needs from simple I/O control to complex motion control. These products provide exceptional performance and high stability through EtherCAT communication, making them an ideal choice



Comparison table for ICP DAS SubDevice :

Picture				
Product Line	ECAT-2000 Series	EC1 Series	EC2 Series	EC4 Series
Type	Distributed	Plug-in	Distributed	Distributed
Casing	Plastic	Metal(Anti-interference)		Plastic
Interface	RJ45 x 2	ICP DAS plug-in terminal	RJ45 x 2	RJ45 x 2 (coupler)
Performance	1 ms (Typical)	100 μs (Typical)		
I/O points	DIO: max. 32 AI: max. 16 AO: max. 8	DIO: max. 32 AI: max. 16 AO: max. 8		DIO: max. 16*12 AI: max. 8*12 AO: max. 4*12
FOE online update	-	V		
Explicit Device ID	-	V		
Connector	Detachable	-	Detachable	
Lockable RJ45	-	user-designed	V	-
Dimensions (WxLxH)	33 x 127 x 108 mm 31 x 157 x 126 mm	20 x 98 x 84 mm	83 x 112 x 65 mm	17 x 98 x 72 mm 24 x 98 x 72 mm

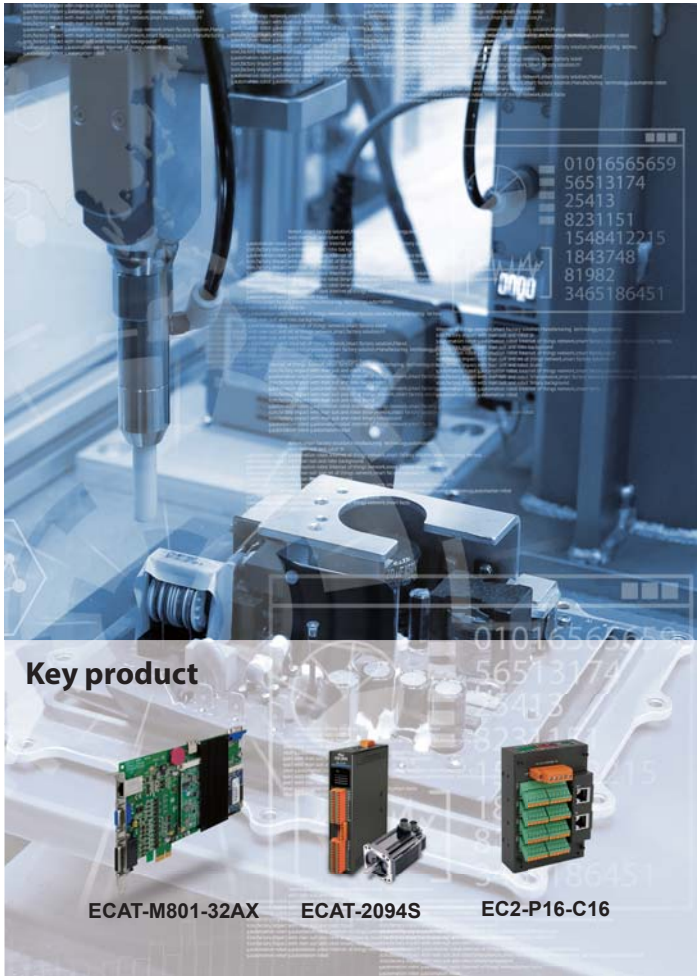

IC Testing & Sorting Machine

EtherCAT features easy development, high expansion and wiring-saving that can easily improve system performance and save space

The ICP DAS EtherCAT Main Device Card ECAT-M801, paired with five ECAT-2094DS stepper motor controllers/Driver and two EC2-P16C16 Digital IO modules, successfully achieves 20-axis control for IC testing and sorting machines. This solution significantly enhances control performance while reducing the machine's footprint, providing reliable and efficient support for high-precision automated testing and sorting applications.

Automation of EV Battery Production Line

Increased Production Capacity and Security with multiple EtherCAT Gateways

As electric vehicles grow rapidly, power battery technology is key. A leading China brand leverages its expertise and patents to standardize high-quality battery production, boosting efficiency and cutting costs. To automate battery processing, they adopted EtherCAT for productivity and high-density layouts. Using ECAT-2610, they integrated Modbus RTU robotic arms into the system, ensuring seamless coordination, efficiency, and safety in production.



Key product

ECAT-2610

Hard Disk Manufacturing Inspection

Efficient product inspection through EtherCAT encoder modules

In hard disk manufacturing, ensuring data reliability is crucial. Before assembly, flash chips undergo quality inspection, and during assembly, tests like stress and reliability are performed. A leading manufacturer uses the ECAT-2073I EtherCAT Three-Channel Incremental Encoder Counter, leveraging EtherCAT's high-speed communication to greatly boost testing capacity and efficiency. With three high-speed channels, strong anti-noise performance, and versatile counting modes, it ensures precise motor control and detects screw failures during production.

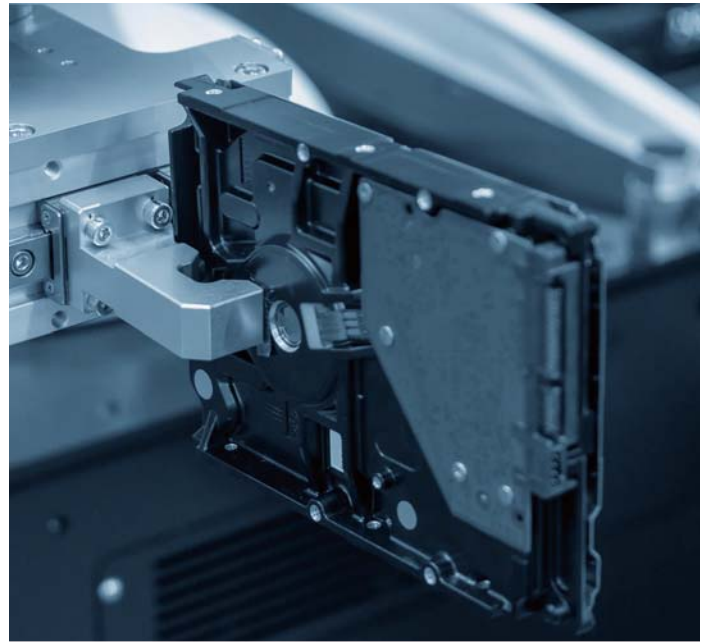

Key product



ECAT-2073



Key product



EMP-9000 Series



ECAT-2094DS



ECAT-2016N

Remotely Controlled Manipulators

Improve performance and reduce complex wiring and system size through EtherCAT communication

The motion simulator serves industries like logistics, oil and gas, OEMs, skill development, research, and defense, offering a safe environment for training novice drivers. Initially, the platform used a bulky IPC and multi-axis cards. To reduce weight, size, and wiring complexity, the user switched to the ICP DAS EMP-9051-16 EtherCAT controller, paired with the ECAT-2094DS stepper motor controller and ECAT-2016N load sensor module, providing force feedback to the steering wheel and simulating real driving scenarios.

7.2 Fieldbus I/O Products

Fieldbus is an industrial network system designed for real-time distributed control and communication between field devices such as sensors, actuators, and controllers. Compared to traditional point-to-point wiring, Fieldbus utilizes a digital communication network that enhances efficiency, simplifies wiring complexity, and improves system diagnostics.

To facilitate seamless connectivity and data exchange among various industrial automation devices, ICP DAS offers a wide range of communication products that support widely used Fieldbus protocols and interfaces.



Fieldbus Features and Comparison

- **Real-Time Data Exchange**

Enable fast and deterministic communication for real-time control.

- **Scalability**

Fieldbus networks can be expanded easily by adding new devices without major rewiring.

- **Better Process Control**

Provides synchronization, event reporting, and alarm management.

- **Interoperability**

Standardized protocols allow devices from different manufacturers to work together.

Feature	CANopen	DeviceNet	PROFIBUS	PROFINET	EtherNet/IP	BACnet/IP
Wiring Medium	Twisted Pair		RS-485	Ethernet		
Max. Speed	1 Mbps	500 kbps	12 Mbps	100 Mbps	-	-
Max. Nodes	127	64	126	256+	256+	65535
Real-Time	Medium		High	Very High	High	Medium
Topology	Bus		Bus / Tree	Star / Tree		Star
Advantages	Simple, Low Cost	Robust	Reliable, High-Speed	Real-Time, High-Speed	Wide Adoption	BA Standard

7.2.1 CANopen Modules

ICPDAS provides a wide range of CANopen products, including master cards, slave I/Os, and gateways to meet our customers' needs. CAN-2000C and CAN-8x23 series are CANopen I/O modules that adhere to the CANopen specifications CiA-301 and CiA-401. The input data from the modules can trigger events or Timer Trigger based on timers. Each I/O module provides EDS files (including Object Dictionary, SDO, PDO SYNC, and more) compliant with the CANopen master interface communication standard.

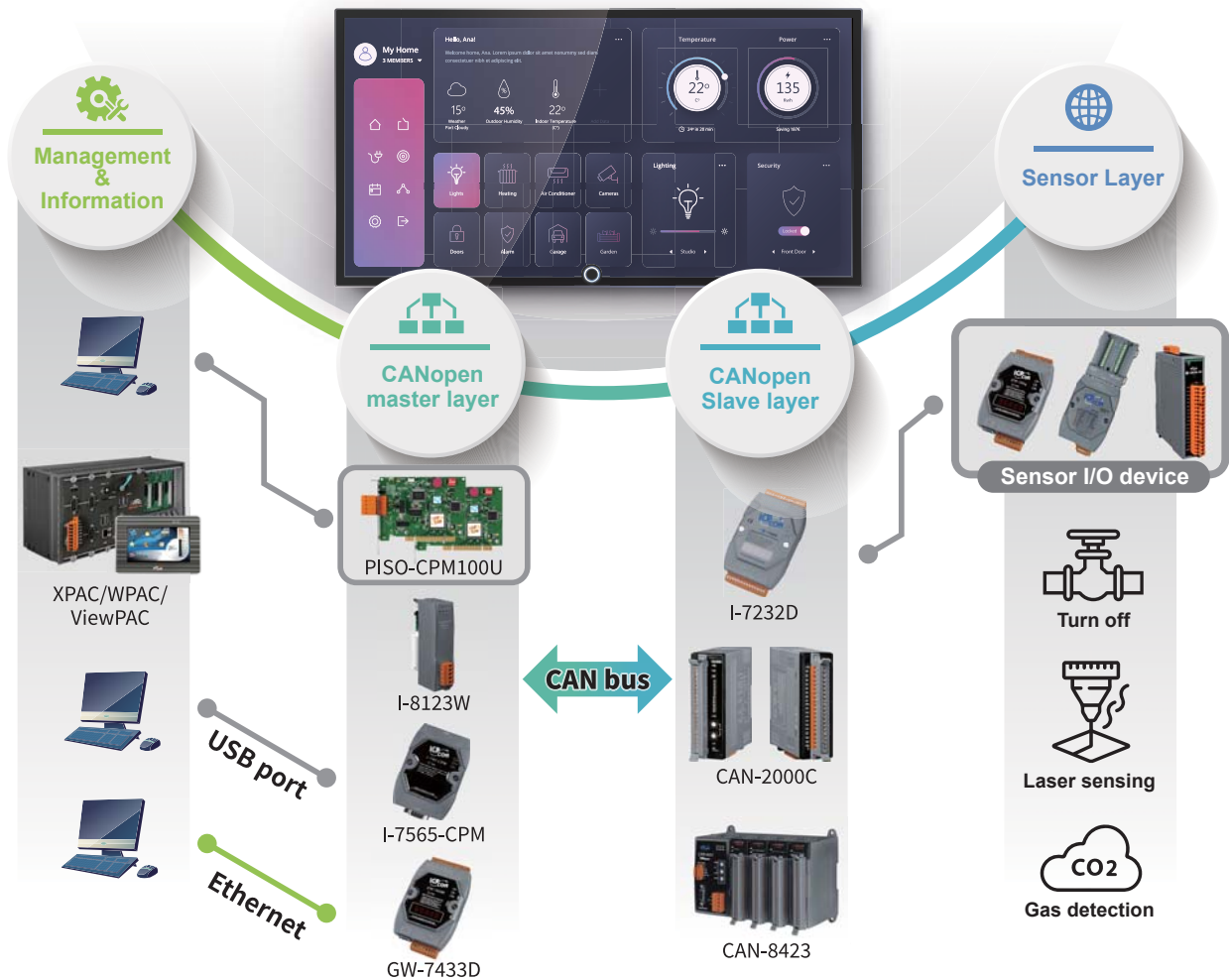

CANopen Features and Advantages:

CANopen is a standardized embedded network protocol based on the CAN bus, known for its flexibility, high security, and reliability. CANopen enhances real-time and synchronization capabilities and offers various sub-protocols for different device applications. This has expanded its application scope to include transportation vehicles and medical devices.

Stability

CANopen is a communication protocol based on the CAN bus, which is highly interferential and secure.

Wide Applications

CANopen is the standard protocol widely use in automatic factory, hospitals, transportation with demand for stability

Object Dictionary Based

Object Dictionary is vital in CANopen, enabling the master controller to control devices by reading and writing data.

CANopen communication Objects:

- **NMT**

Manage device status and connectivity.

- **SYNC**

Synchronizes cyclic data exchange between nodes

- **SDO**

Setting up the Read Object Dictionary.

- **EMCY**

Sending Error Message

- **PDO**

Enables real-time I/O data transmission

- **Event & Timer**

Input data from I/O modules trigger by timers.

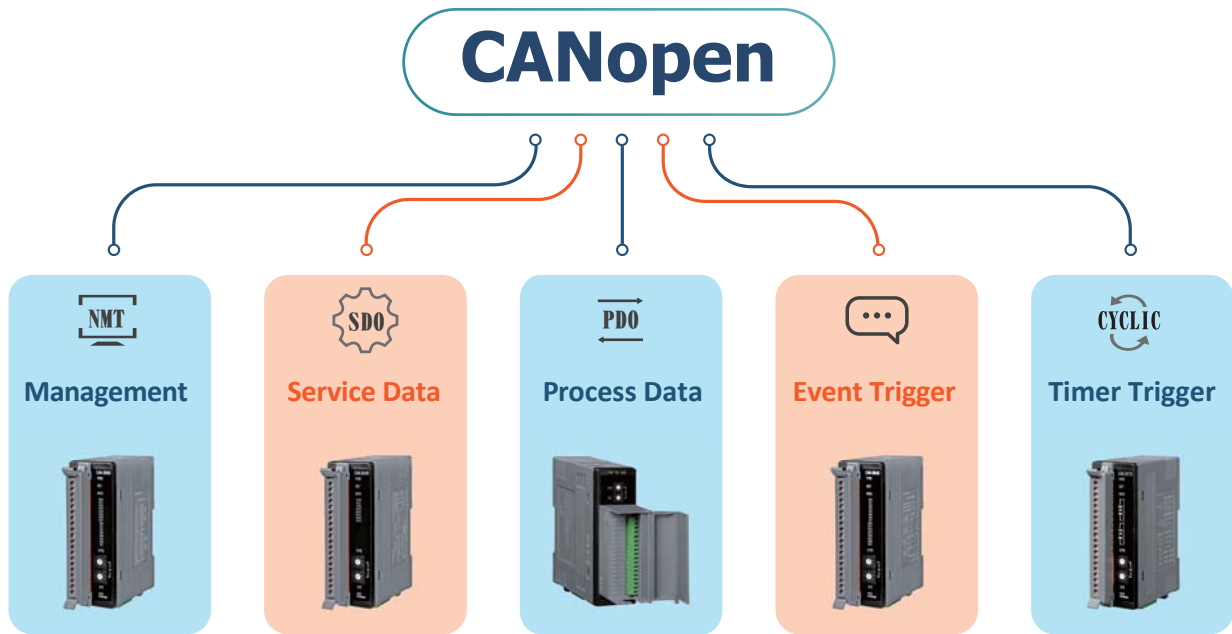

Application:

Internal wind tower equipment, including variable frequency units, uses robust CANopen communication with strong interference resistance. Each wind tower is equipped with CANopen I/Os and a GW-7433D gateway, allowing the control center to monitor the wind tower status using Modbus TCP commands.

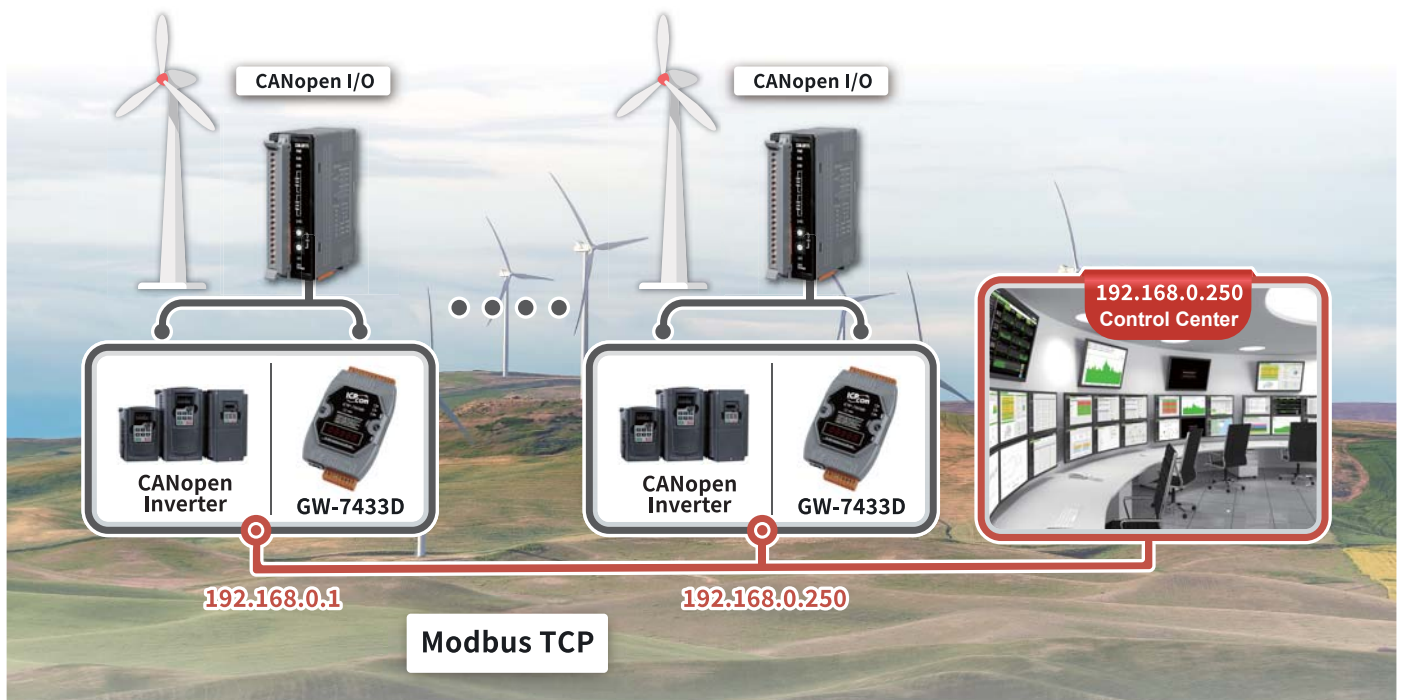

Selection Guides:

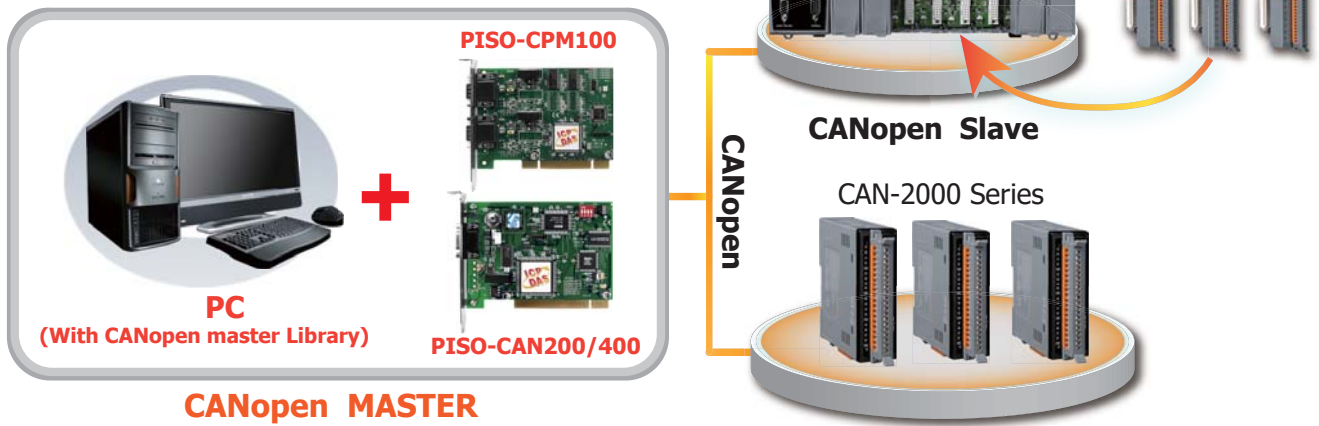

✓ CANopen Analog I/O

Model Name		Analog Input			Analog Output	
		CH.	Input Range	Sensor	CH.	Output Range
	CAN-2015C	8	-	RTD: Pt100, Pt1000, Ni120, Cu100, Cu1000	-	-
	CAN-2017C	8	±10 V, ±5 V, ±1 V, ±500 mV, ±150 mV, ±20 mA	-	-	-
	CAN-2018C/S	8	±2.5 V, ±1 V, ±500 mV, ±100 mV, ±50 mV, ±15 mV, ±20 mA	Thermocouple (J, K, T, E, R, S, B, N, C)	-	-
	CAN-2019C/S	10	±10 V, ±5 V, ±2.5 V, ±2 V, ±500 mV, ±100 mV, ±50 mV, ±15 mV, ±20 mA		-	-
	CAN-2019C/S2			-	-	
	CAN-2024C	-	-	-	4	0 ~ +5 V, ±5 V, 0 ~ +10 V, ±10 V, 0 ~ 20 mA, +4 ~ 20 mA

✓ CANopen Digital I/O

Model Name		Digital Input / Counter			Digital Output		
		CH.	Contact	Sink / Source	CH.	Type	Output Range
	CAN-2053C	16	Wet	Sink / Source	-	-	700 mA
	CAN-2054C	8			8	Sink	
	CAN-2055C	8			8	Source	
	CAN-2057C	-	-	-	16	Sink	
	CAN-2060C	4	Dry / Wet	Sink / Source	4	Relay(FormA)	5 A





 CANopen Multifunction I/O

Model		AI		AO		DI		DO	
		CH.	Type	CH.	Type	CH.	Type	CH.	Type
	CAN-2022C	2	±10 V, ±5 V, ±2.5 V, ±1.25 V, ±1 V, ±500 mV, ±250 mV	2	0 ~ +5 V, 0 ~ +10 V, ±5 V, ±10 V	4	Wet (Sink)	4	Sink
	CAN-2026C	6	±10 V, ±5 V, ±1 V, ±500 mV, ±150 mV, ±20 mA	2		2		1	

 CANopen Counter / PWM I/O

Model		Counter Input			PWM Output		
		CH.	Signal	Resolution / Speed	CH.	Load	Resolution / Speed
	CAN-2084C	4/8	Up, Up/Down, Dir/Pulse, A/B Phase, Frequency	32 bit / 250 kHz	-	-	-
	CAN-2088C	6	Up Counter	32 bit / 500 kHz	8	1 mA	16 bit / 500 kHz

 CANopen Remote I/O Unit

Model		Slot	Module Supports
	CAN-8123-G	1	<p>I-8KW & I-87KW I/O Modules (See Chapter 5.2)</p> 
	CAN-8223-G	2	
	CAN-8423-G	4	
	CAN-8823-G	8	

7.2.2 DeviceNet Modules

ICPDAS provides a wide range of DeviceNet products, including master cards, slave I/Os, and gateways to meet our customers' needs. CAN-2000D and CAN-8x24 series are DeviceNet I/O modules that adhere to the DeviceNet specifications Volume I/II Release 2.0. The input data from the modules can auto-respond when changing on data from Event Trigger or Timer Trigger. Each I/O module provides EDS files for DeviceNet master, so that DeviceNet master can easily read status from the I/O modules.

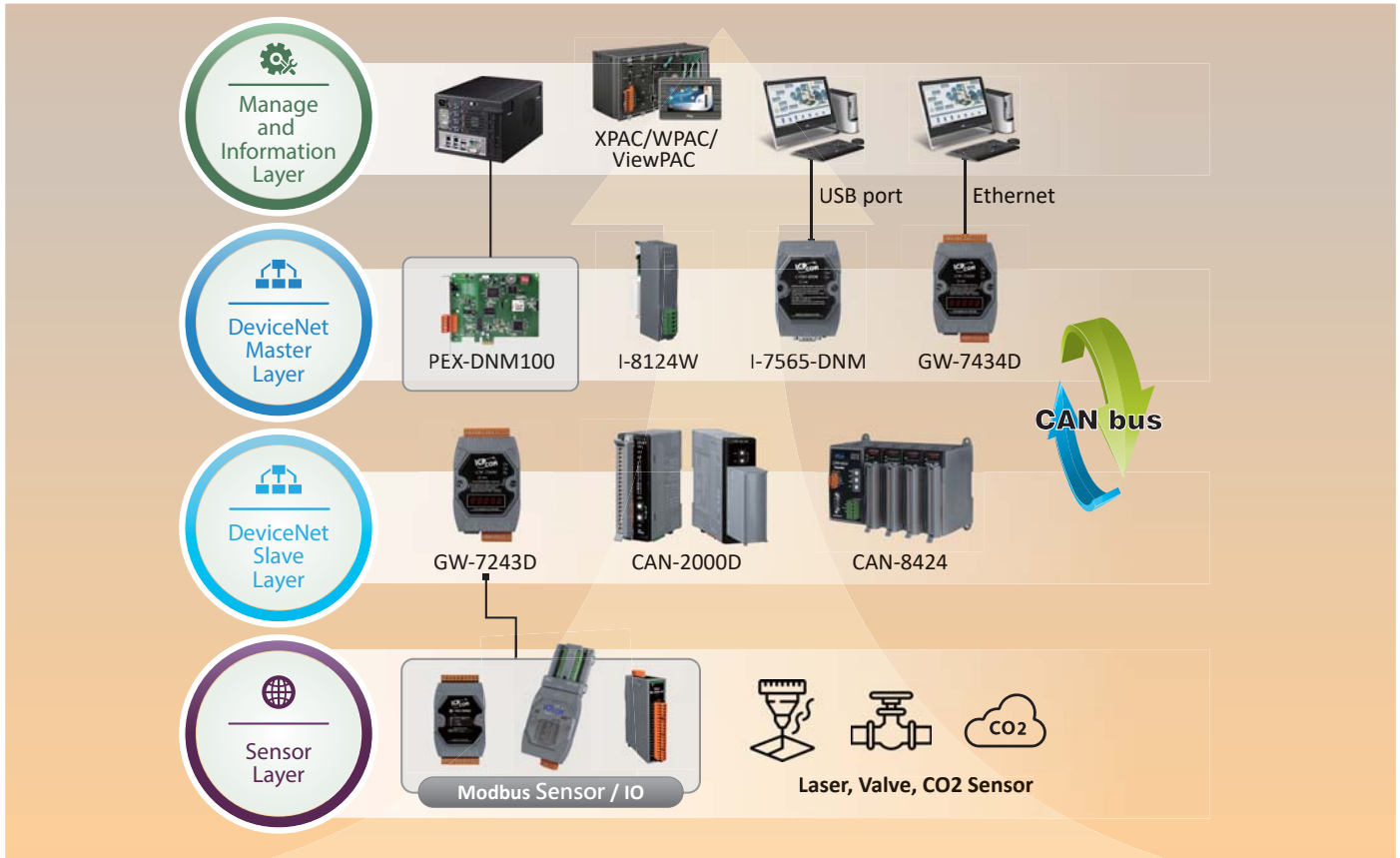

DeviceNet Features and Advantages:

DeviceNet is an open communication protocol that enables various industrial devices to work together and share information in real time on the DeviceNet network.

Stable CAN bus

DeviceNet is a communication protocol based on CAN bus, which can maintain high security and excellent communication performance in harsh environments full of noise.

Wide Range of Applications

DeviceNet has been widely used in various fields, even in complex semiconductor manufacturing, it is the most common application, which shows its excellent stability.

Connection-based

DeviceNet is a connection-based protocol. The main control terminal must establish a connection with the device first. After the connection is established, in addition to providing a data exchange between the device and the controller, it also establishes network management and online debugging mechanism.

DeviceNet and ODVA

DeviceNet is a standard communication protocol used in automation technology and is currently maintained by the Open DeviceNet Vendors Association (ODVA).

DeviceNet communication Objects:

DeviceNet establishes a fast IO connection, which can quickly exchange IO data in Explicit way on the network. Poll is the rapid exchange of input and output data between master and slave nodes. Bit-strobe is a connection method in which the master node sends a request to multiple slave nodes, and the slave nodes transmit the input data to the master node. Change of state (event-triggered) or Cyclic (time-triggered) is a communication method in which the master or slave node sends IO data, and then the receiving node responds to the acknowledgement message.

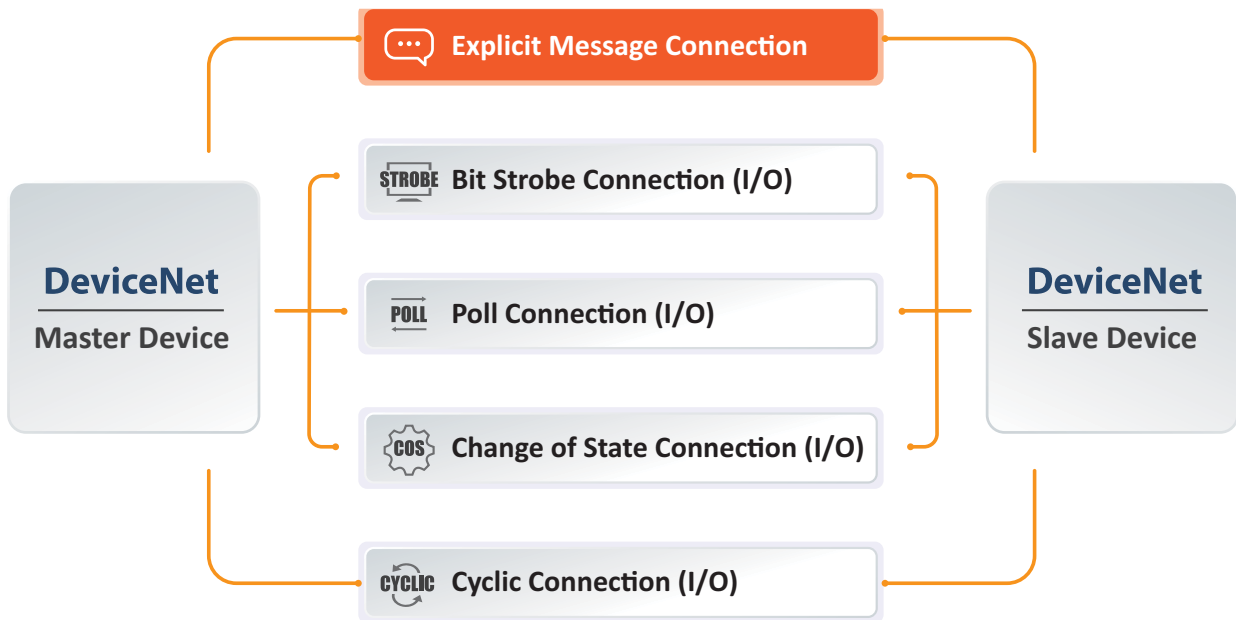

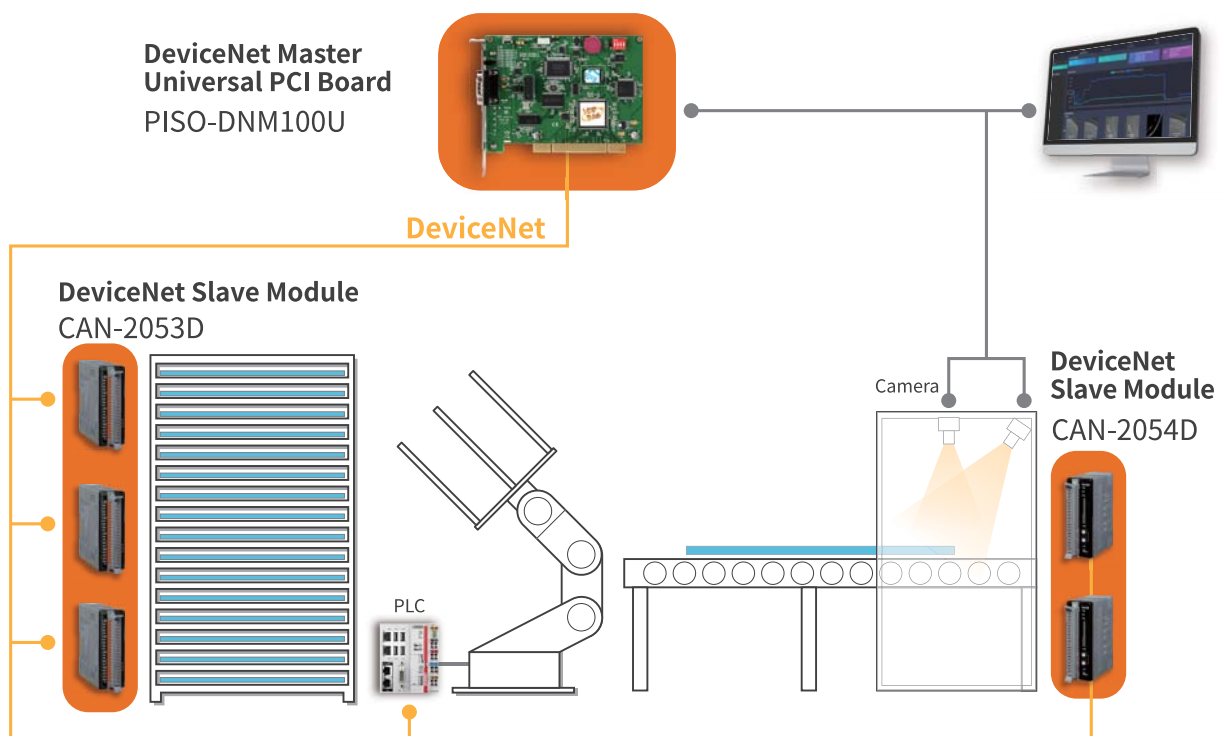

Application:

The system is designed to inspect glass for defects like bubbles or cracks. A robot arm places the glass on a conveyor for visual inspection. This arm, controlled by a Beckhoff PLC with a DeviceNet interface, operates with a custom program. To integrate multiple micro switches and sensors into the DeviceNet network, ICP DAS CAN-2053D I/O modules are used, saving space and simplifying integration.



Selection Guides:

✓ DeviceNet Analog I/O

Model	Analog Input			Analog Output	
	CH.	Input Range	Sensor	CH.	Output Range
 CAN-2018D/S	8	$\pm 2.5\text{ V}$, $\pm 1\text{ V}$, $\pm 500\text{ mV}$, $\pm 100\text{ mV}$, $\pm 50\text{ mV}$, $\pm 15\text{ mV}$, $\pm 20\text{ mA}$	Thermocouple (J, K, T, E, R, S, B, N, C)	-	-
 CAN-2017D/S	8	$\pm 10\text{ V}$, $\pm 5\text{ V}$, $\pm 1\text{ V}$, $\pm 500\text{ mV}$, $\pm 150\text{ mV}$, $\pm 20\text{ mA}$	-	-	-
CAN-2024D	-	-	-	4	0 ~ +5 V, $\pm 5\text{ V}$, 0 ~ +10 V, $\pm 10\text{ V}$, 0 ~ +20 mA, +4 ~ +20 mA



✓ DeviceNet Digital I/O

Model	Digital Input / Counter			Digital Output		
	CH.	Contact	Sink / Source	CH.	Type	Max. Load
 CAN-2053D	16	Wet	Sink / Source	-	-	700 mA
CAN-2054D	8			8	Sink	
CAN-2055D	8			8	Source	
CAN-2057D	-	-	-	16	Sink	5 A
CAN-2060D	4	Wet / Dry	Sink / Source	4	Relay (Form A)	

✓ DeviceNet Counter / PWM I/O

Model	Counter Input			PWM Output		
	CH.	Signal	Resolution / Speed	CH.	Load	Resolution / Speed
 CAN-2088D	8	Up Counter	32 bit / 500 kHz	8	-	16 bit / 500 kHz

✓ DeviceNet Remote I/O Unit

Model	Slot	Module Supports
 CAN-8124-G	1	I-8KW & I-87KW I/O Modules (See Chapter 5.2)
 CAN-8224-G	2	
 CAN-8424-G	4	

7.2.3 PROFIBUS Modules

PROFIBUS, introduced in 1989 by BMBF, is a leading fieldbus standard with over 31 million devices installed by 2009, including 5.4 million in process industries. It is suitable for both fast, time-critical applications and complex communication tasks. ICP DAS offers various PROFIBUS DP I/Os like the PROFI-5000 and PROFI-8x55 series, supporting AI, AO, DI, DO, PWM, and more. These modules can be easily configured using GSD files in any PROFIBUS Configurator, simplifying system integration.

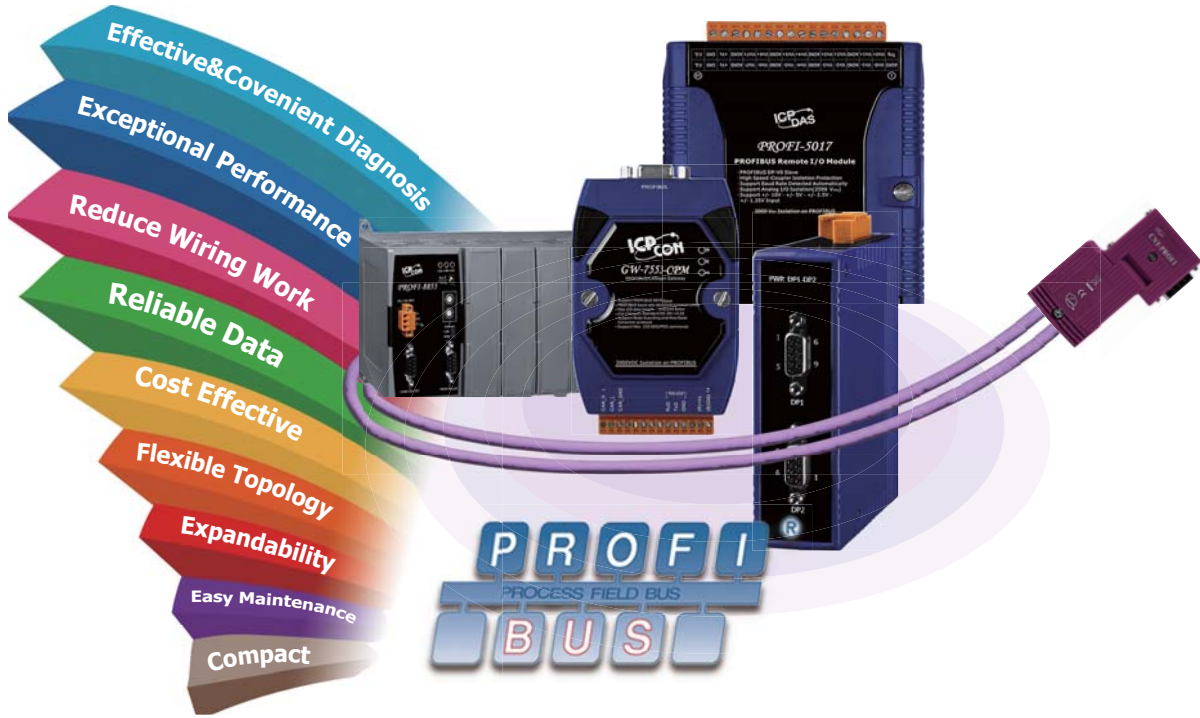

PROFIBUS Module Features:

- ❖ **Standardized Communication**
A standardized open protocol that supports a wide range of applications.
- ❖ **High-Speed Data Transfer**
PROFIBUS DP can operate at speeds up to 12 Mbps, which is highly beneficial for applications requiring rapid operations and data exchange.
- ❖ **Multiple Master**
A "token" is passed between masters, and whichever master is holding the token has the exclusive ability to communicate with slave devices on the network.
- ❖ **Comprehensive Diagnostics**
Offers comprehensive diagnostic capabilities. It allows for monitoring and maintenance of network health.

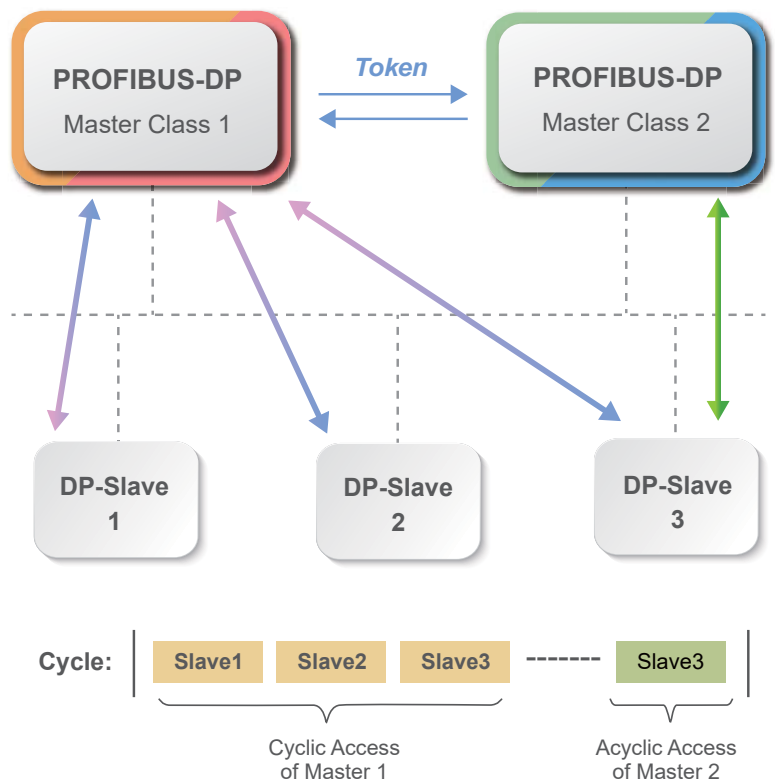

PROFIBUS Benefits:

Benefits in Perspectives



Plant Sites

- Cutting-Edge Technology
- Seamless Migration
- Effortless Upgrades
- Cost-Effective Enhancements
- Extended Operational Lifespan



Managers

- Optimized Costs
- Agile & Efficient Production
- Superior Product Quality
- Enhanced Safety Standards
- Maximized ROI

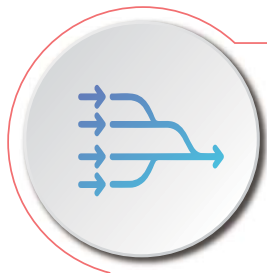

Engineers

- Minimal Wiring & Hardware
- Accelerated Engineering
- Broad Vendor Selection
- Streamlined Commissioning
- Simplified Documentation



Operators

- Full Transparency to Sensor Level
- Enhanced Maintenance Efficiency
- Optimized Asset Management
- Minimized Plant Downtime
- Increased Production Flexibility

Applications:



Process Automation in Chemical Industry

- Ensures accurate real-time measurement of pressure, temperature, and flow.
- Operates safely in hazardous environments.
- Enables centralized control and monitoring via DCS and SCADA.
- Provides real-time device health feedback to prevent failures and optimize maintenance.



Factory Automation in Automotive Field

- Supports fast cyclic updates with deterministic communication for real-time control.
- Provides millisecond response times for assembly lines.
- Advanced diagnostics allow early fault detection, preventing costly downtimes.
- Easy configuration and scalability with standardized device profiles (GSD files).



Water Treatment for Infrastructure

- Connects field devices like pumps, valves, and flow meters to a central control room.
- Integrates power monitoring systems to reduce energy consumption in pumping stations.
- Operates reliably in electrically noisy environments, ensuring stable communication.
- Supports thousands of I/O points across distributed locations.

Selection Guides:





✓ PROFIBUS Analog I/O

Model		Analog Input			Analog Output	
		CH.	Input Range	Sensor	CH.	Output Range
	PROFI-5017	8	±10 V, ±5 V, ±2.5 V, ±1.25 V	-	-	-
	PROFI-5017C	8	0 ~ 20 mA	-	-	-
	PROFI-5018/S	10	±15 mV, ±50 mV, ±100 mV, ±500 mV, ±1 V, ±2.5 V, ±20 mA, 0 ~ 20 mA, 4 ~ 20 mA	Thermocouple: J, K, T, E, R, S, B, N, C	-	-
	PROFI-5024	-	-	-	4	±10 V, 0 ~ 20 mA, 4 ~ 20 mA

✓ PROFIBUS Digital I/O

Model		Digital Input / Counter			Digital Output		
		CH.	Contact	Sink / Source	CH.	Type	Max. Load
	PROFI-5045	-	-	-	24	Sink	650 mA
	PROFI-5050	16	Dry	Sink / Source	8	Sink	30 mA
	PROFI-5051	24	Wet	Sink / Source	-	-	-
	PROFI-5052	12			-	-	-
	PROFI-5053	24	Dry	-	-	-	-
	PROFI-5055	8	Wet	Sink / Source	8	Sink	650 mA
	PROFI-5060	8			4	Relay (Form C)	2 A

✓ PROFIBUS Remote I/O Unit

Model	Slot	Module Supports
	PROFI-8155-G PROFI-8255-G	 I-8KW & I-87KW I/O Modules (See Chapter 5.2)
	PROFI-8455-G	
	PROFI-8855-G	

7.2.4 PROFINET Modules

ICP DAS offers hardware solutions tailored for diverse PROFINET applications, addressing challenges in data acquisition, communication protocol conversion, and interface conversion. These solutions enable seamless completion of PROFINET application projects. The PFN-2000 series comprises PROFINET analog and digital I/O modules, which users can effortlessly configure with any PROFINET engineering tool using the GSDML file.

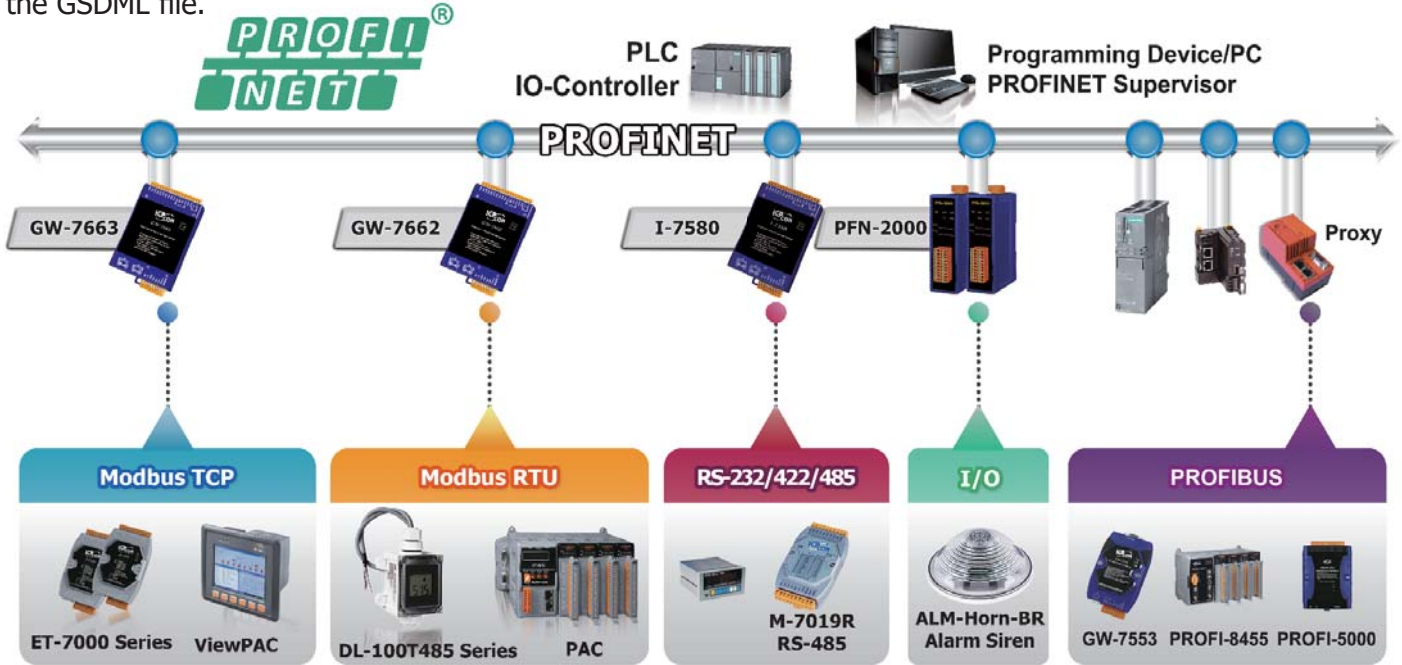

PROFINET Communication Channels:

PROFINET's combination of high performance and openness stems from its data channel design. It includes a reasonable design of three communication channels, which can realize the transmission of various data on one network cable and perform their respective functions effectively according to the application requirements.

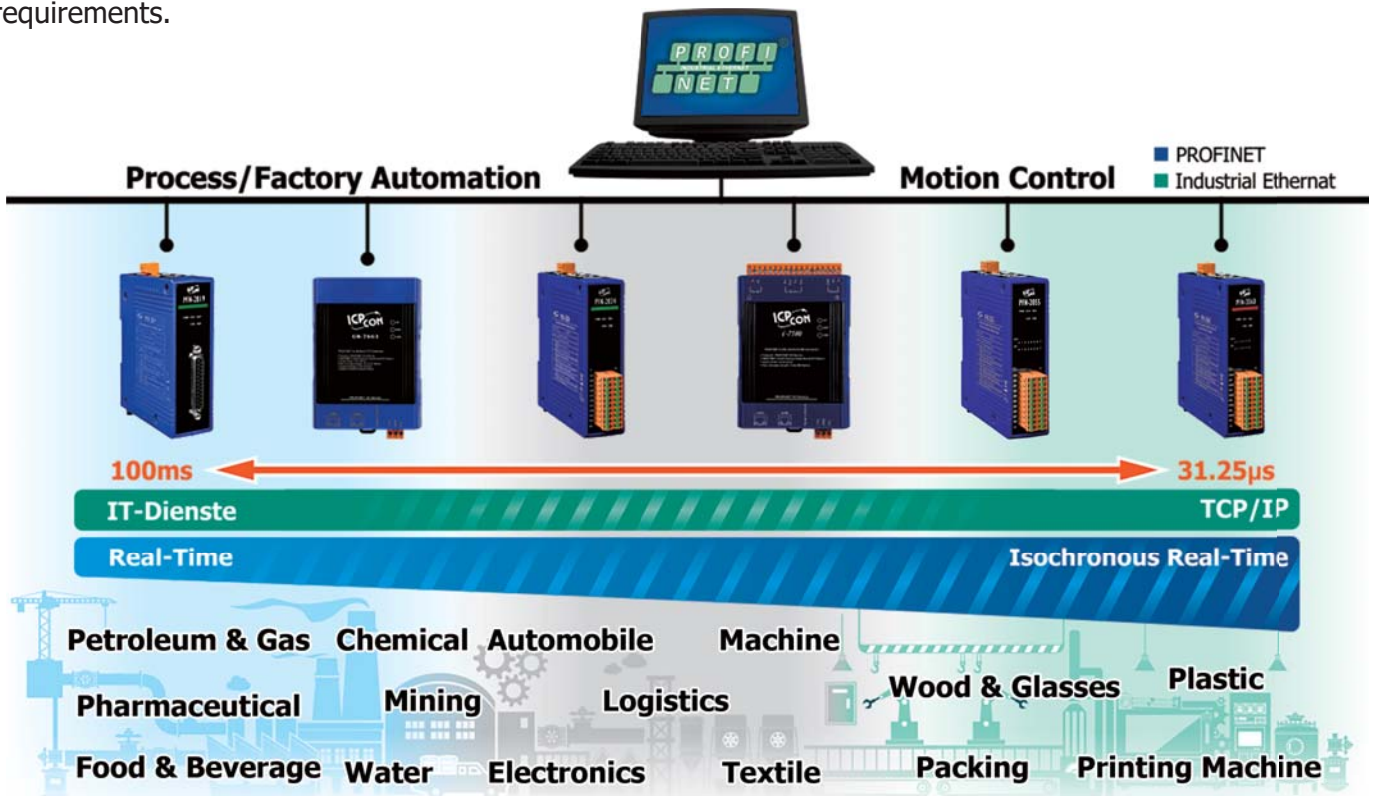

PROFINET Features:

PROFINET is an open Industrial Ethernet standard developed by the PROFIBUS Organization (PI). It enables seamless vertical integration between field and enterprise levels and supports real-time automation for various industrial applications, including factory automation, process automation, safety systems, and motion control. Additionally, PROFINET allows the integration of existing field bus systems like PROFIBUS DP, PROFIBUS PA, AS-Interface, INTERBUS, and DeviceNet without modifying field devices, protecting prior investments.

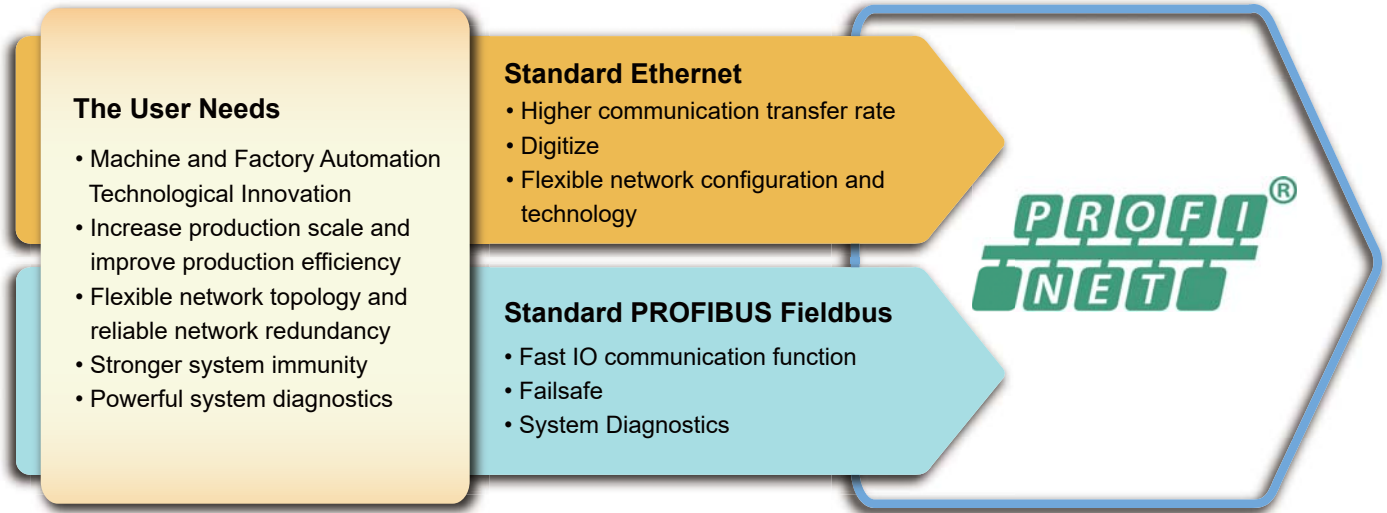

Selection Guides:

PROFINET Analog I/O

Model		Analog Input			Analog Output	
		CH.	Input Range	Sensor	CH.	Output Range
	PFN-2019/S	10	±15 mV, ±20 mA, ±50 mV, ±100 mV, ±500 mV, 0 ~ +20 mA, +4 ~ +20 mA, ±1 V, ±2.5 V	Thermocouple (J, K, T, E, R, S, B, N, C)	-	-
	PFN-2024	-	-	-	4	0 ~ 5 V, ±5 V, 0 ~ 10 V, ±10 V, 0 ~ 20 mA, 4 ~ 20 mA

PROFINET Digital I/O

Model		Digital Input / Counter			Digital Output		
		CH.	Contact	Sink / Source	CH.	Type	Max. Load
	PFN-2042	-	-	-	16	Sink	700 mA
	PFN-2051	16	Dry / Wet	Dry: Source Wet: Sink / Source	-	-	-
	PFN-2052	8	Wet	Sink / Source	-	-	-
	PFN-2053	16	Dry	Source	-	-	-
	PFN-2055	8	Dry / Wet	Dry: Source Wet: Sink / Source	8	Sink	700 mA
	PFN-2060	6			6	Relay (Form A)	2 A @ 30 VDC 0.6 A @ 125 VAC

7.2.5 EtherNet/IP Modules

The EIP-2000 is an industrial remote I/O module series supporting the EtherNet/IP protocol. Users can seamlessly integrate these modules into the Ethernet network from the industrial floor to the enterprise. The EIP-2000 allows daisy chain connection which permits the flexibility in locating devices, eases installation and lowers infrastructure costs. All the modules can be deployed in the network topologies such as star, line or ring. The isolation design protects the EIP-2000 against the harmful interference.

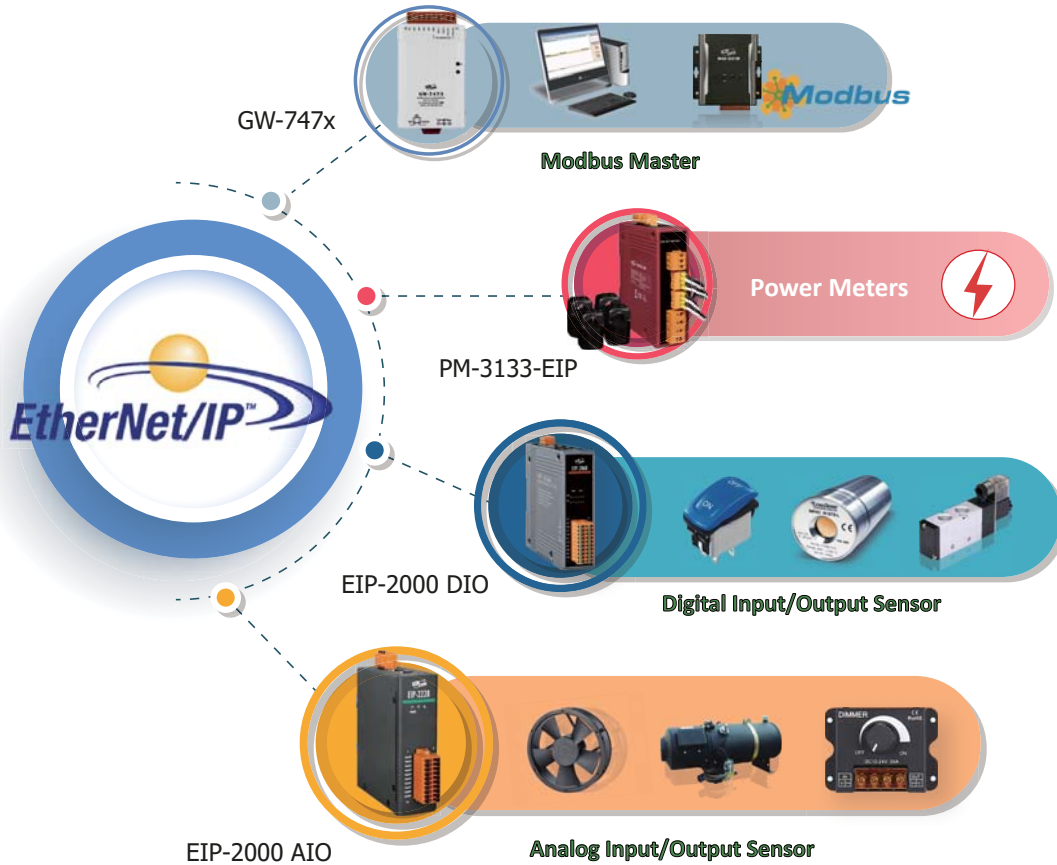

Applications:

In the screw factory, screws and other components need to be counted at the same time. ICP DAS provides GW-7473 and EIP-2000 module solutions, so that the user does not need to use PLC as the EtherNet/IP scanner. The EIP-2000 module can receive I/O status messages and publish the messages to GW-7473. Users can use Modbus RTU or Modbus TCP on the PC to read the data.

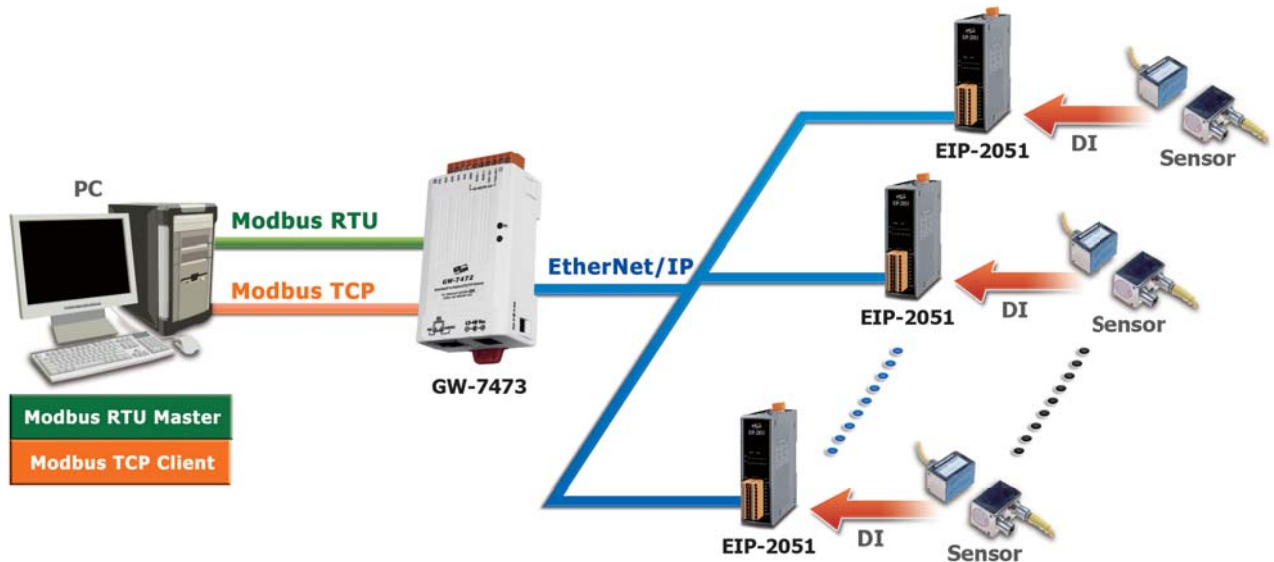

EtherNet/IP Features:

❖ Topology



EIP-2000 supports Star/Bus/Daisy-Chain/Ring topology connections. It is convenient to deploy the EtherNet/IP network and its applications.

❖ Utility

ICPDAS offers the EIP-2000 Utility for configuring and testing EIP-2000 series I/O modules, enabling easy EtherNet/IP I/O monitoring without a PLC.

Selection Guides:

✓ EtherNet/IP Analog Input Modules

Model	CH.	Input Range	Sensor	Resolution	Sampling
 EIP-2017	8/16	±150 mV, ±500 mV, ±1 V, ±5 V, ±10 V, ±20 mA, 0 ~ +20 mA, +4 mA ~ +20 mA	-	16-bit	10 Hz
 EIP-2217			-	Normal: 16-bit Fast: 12-bit	Normal: 20 Hz Fast: 200 Hz
 EIP-2019/S	8	±15 mV, ±50 mV, ±100 mV, ±150 mV, ±500 mV, ±1 V, ±2.5 V, ±5 V, ±10 V, ±20 mA, 0 ~ +20 mA, +4 ~ +20 mA	Thermocouple (B, C, E, J, K, N, R, S, T)	16-bit	10 Hz

✓ EtherNet/IP Analog Output Modules

Model	CH.	Input Range	Resolution	Response Time
 EIP-2228	8	0 ~ +5 VDC, ±5 VDC, 0 ~ +10 VDC, ±10 VDC, 0 ~ 20 mA, 4 ~ 20 mA	12-bit	1 ms per channel

✓ EtherNet/IP Digital I/O

Model	Digital Input / Counter			Digital Output		
	CH.	Contact	Sink / Source	CH.	Type	Max. Load
 EIP-2042	-	-	-	16	Sink	700 mA
EIP-2051	16	Dry / Wet	Sink / Source	-	-	-
EIP-2055	8	Dry / Wet	Sink / Source	8	Sink	700 mA
EIP-2060	6			6	Relay (Form A)	5 A

7.2.6 BACnet Modules

BACnet (Building Automation and Control Networks) was designed to allow communication of building automation and control systems for applications such as heating, ventilating, and air-conditioning and their associated equipment. The BNET-2310M is a multifunctional BACnet/IP IO module, featuring 4 AI channels, 2 AO channels, 4 DI channels, and 4 DO channels. The module contains multiple BACnet objects, including Device, AI, AO, BI, and BO, and supports various BIBBS (such as DS-RP-B, DS-RPM-B, DS-WP-B, DS-WPM, DS-COV-B, etc.).

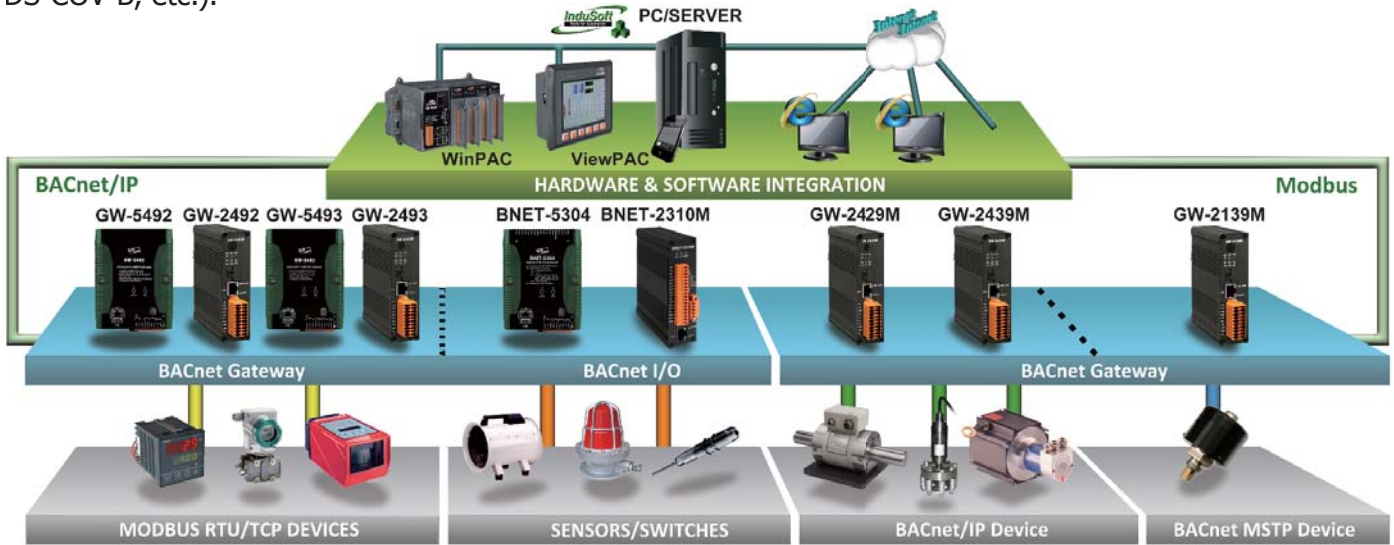

BACnet/IP I/O Features:

❖ Standard Protocol

Follows ASHRAE Standard 135, ensuring interoperability across different systems.

❖ Scalability & Interoperability

Supports small to large-scale systems
Allows integration of devices from multiple manufacturers without compatibility issues.

❖ Read/Write Object Properties

Including Device / AI / AO/ BI / BO, and various BIBBS supported.

❖ Web-based Tool

The module has a built-in web server, allowing users to easily and securely configure the module remotely via a web interface.

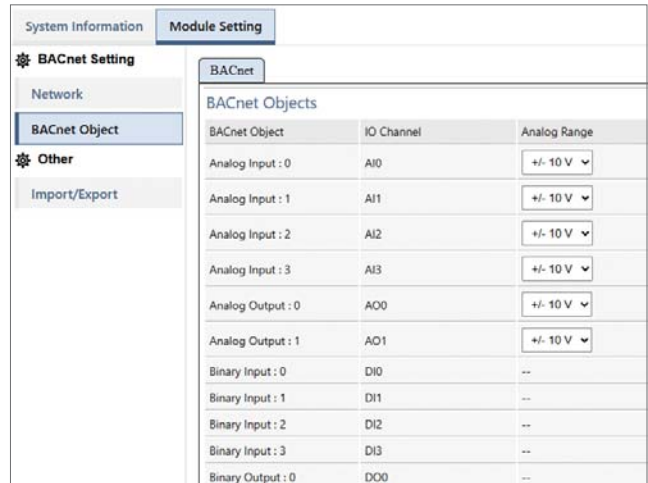

Selection Guides:

BACnet/IP Multifunction I/O

Model	AI		AO		DI		DO	
	CH.	Type	CH.	Type	CH.	Type	CH.	Type
 BNET-2310M	4	±1 V, ±2.5 V, ±5 V, ±10 V	2	0 ~ +5 V, 0 ~ +10 V, ±5 V, ±10 V	4	Dry (Source)	4	Source

7.3 Wireless I/O Products

Wireless communication technologies convert serial communication and Ethernet from industrial equipment into **Wi-Fi**, **ZigBee**, and **Sub-GHz** wireless methods for seamless data transmission. These solutions effectively handle communication in large areas and environments where wiring is challenging due to terrain constraints. By eliminating the need for wired infrastructure, wireless I/O technologies enable flexible, scalable, and cost-effective solutions for industrial automation, smart buildings, and IoT applications.

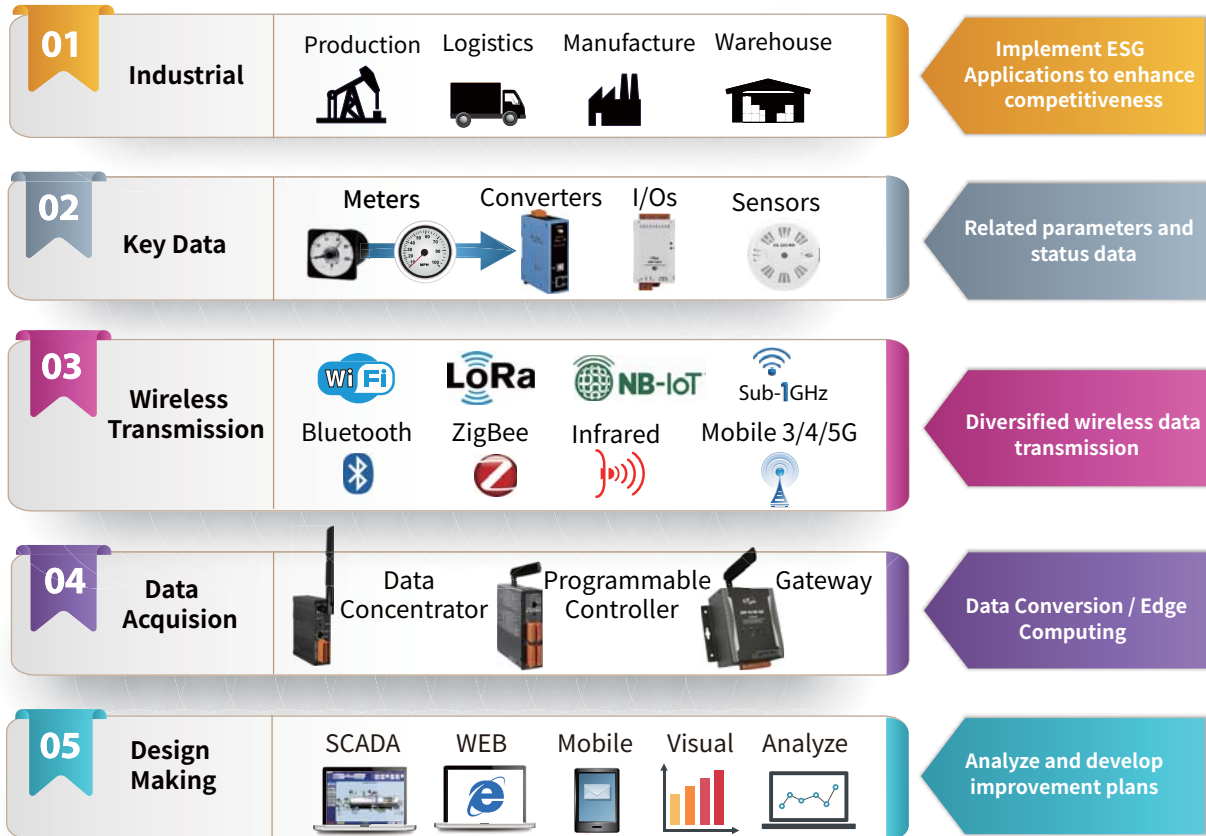

Wireless Module Features

By leveraging Wi-Fi, ZigBee, and Sub-GHz, businesses and industries can achieve enhanced automation, energy efficiency, and cost savings while ensuring reliable, real-time data transmission.

Wi-Fi

- Full-Duplex Data Transmission
- High-speed Data Rates
- Reliable & Secure Connectivity

IEEE 802.11a/b/g/n
Wi-Fi I/O MODULE

ZigBee

- Mesh Networking for Extended Coverage
- Low Power Consumption
- Secure private network

IEEE 802.15.4
ZigBee I/O MODULE

Sub-1GHz

- Excellent Penetration Through Obstacles
- Resistant Signal Disruptions
- Star Topology

433 / 920 MHz
RF MODULE

Each wireless technology has its own characteristics and is suitable for different scenarios. The suitability comparison and application scenarios of various types of wireless are as follows:

Type	Frequency Band	Dist.	Data Rate	Consumption	Topology
Wi-Fi	2.4 GHz / 5 GHz	50 M	High	High	Star
ZigBee	2.4 GHz	700 M	Medium	Low	Star / Mesh / Cluster Tree
Sub-1GHz	433 MHz / 920 MHz	700 M	Low	Medium	Star



7.3.1 Wi-Fi Modules

Wi-Fi has become an important wireless communication technology due to its wide coverage, fast transmission speed, low cost, self-deployment, and ease of use. In order to allow data in industrial sites to be connected to Ethernet through Wi-Fi without being restricted by wiring conditions, ICP DAS has launched a variety of Wi-Fi products, including APs, converters, gateways and I/O modules.

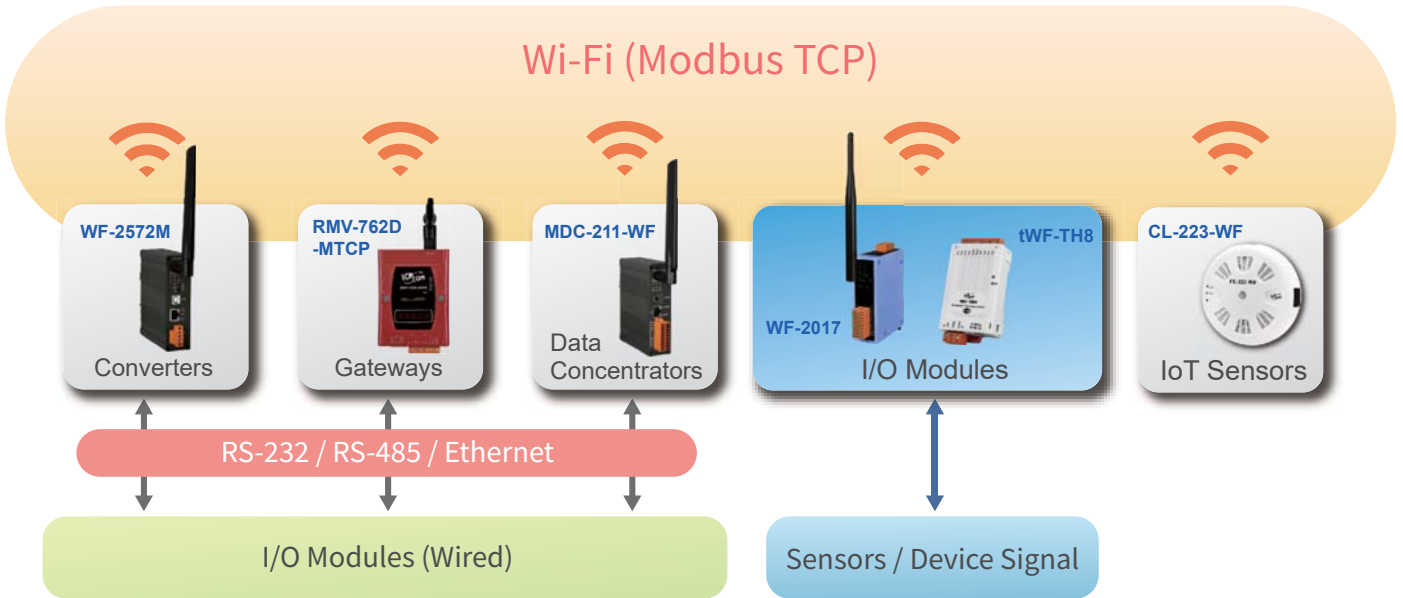
SCADA / Controllers / Work Stations



Wi-Fi I/O Modules Comparison Table

Product Line	WF-2000	WF-2200	tWF
Pictures			
Wi-Fi Frequency	2.4 GHz	2.4 / 5 GHz	2.4 GHz
Standard	IEEE 802.11 b/g/n	IEEE 802.11 a/b/g/n	IEEE 802.11 b/g/n
Mode	Infrastructure & Limit AP		
Encryption	WEP / WPA / WPA2-PSK		
Protocol	Modbus TCP/UDP		Modbus TCP
Software Utility	Windows	Windows / Web Browser	
Antenna	External		Internal
Form Factor	Slim Type		Tiny Size
DIN-Rail Space	3.3 cm		5.2 cm

Features:

❖ Reduced Cabling Cost

Eliminates the need for extensive wiring, reducing installation and maintenance costs. Ideal for remote or hard-to-reach locations where wiring is impractical.

❖ Integration with IoT

Supports smart manufacturing by connecting sensors, controllers, and industrial systems to IoT platforms. Achieve facilitates predictive maintenance, analytics, and automation.

❖ Flexibility & Scalability



Easy to add or relocate devices without major infrastructure changes. Reduces the need for physical access to hazardous or restricted areas.

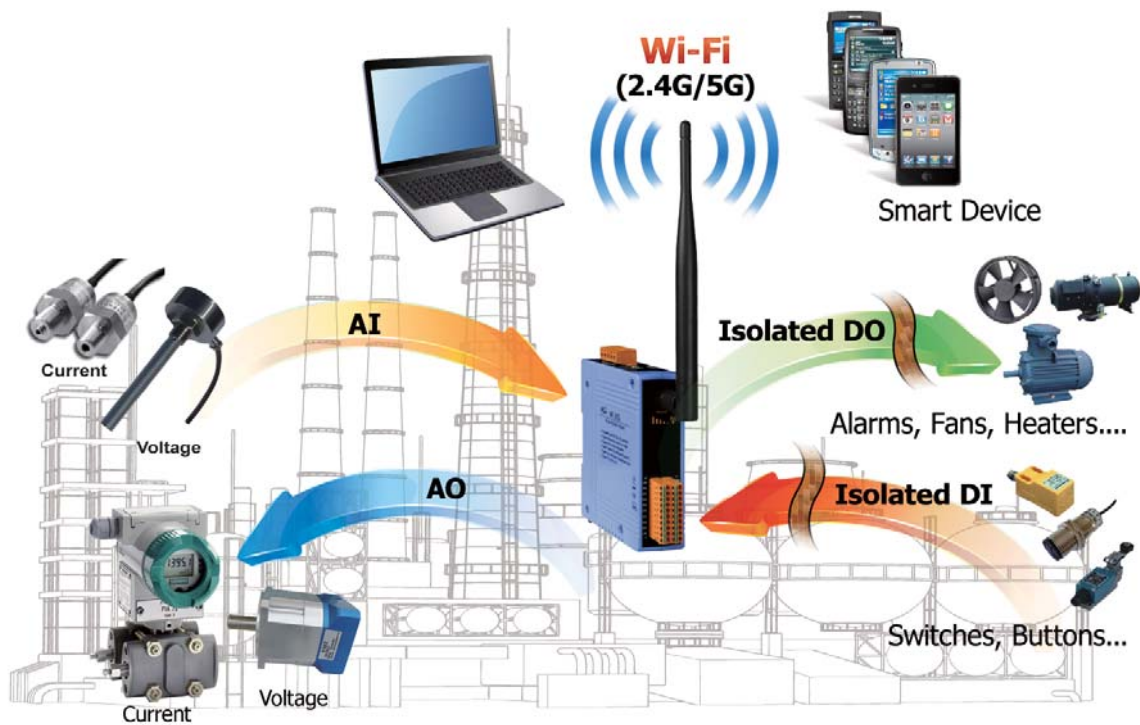

❖ Supports Industrial Protocol

Supports common industrial communication standards (Modbus TCP/IP). Enables seamless integration with existing SCADA, PLCs, and automation systems.

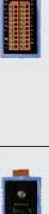



Selection Guides:



Model	Freq.	CH.	Type	Sensor
 WF-2015	2.4 GHz	6	-	RTD: Pt100, PT1000, Ni120, Cu50, Cu100, Cu1000
 WF-2017		8 (DIFF) / 16 (SE)	$\pm 20 \text{ mA}$, $\pm 150 \text{ mV}$, $\pm 500 \text{ mV}$, $0 \sim +20 \text{ mA}$, $+4 \sim +20 \text{ mA}$, $\pm 1 \text{ V}$, $\pm 5 \text{ V}$, $\pm 10 \text{ V}$	-
 WF-2019/S		10	$\pm 15 \text{ mV}$, $\pm 20 \text{ mA}$, $\pm 50 \text{ mV}$, $\pm 100 \text{ mV}$, $\pm 500 \text{ mV}$, $\pm 1 \text{ V}$, $\pm 2.5 \text{ V}$, $\pm 5 \text{ V}$, $\pm 10 \text{ V}$	Thermocouple: J, K, T, E, R, S, B, N, C

Model	Freq.	CH.	Type	Sensor
 WF-2215	2.4 / 5 GHz	6	-	RTD: Pt100, PT1000, Ni120, Cu50, Cu100, Cu1000
 tWF-AD5	2.4 GHz	5	±1.25 V, ±2.5 V, ±5 V, ±10 V	Thermistor
tWF-TH8		8		

 **Wi-Fi Digital & Relay I/O**

Model	Freq.	DI/Counter			DO		
		CH.	Type	Sink/Source	CH.	Type	Max. Load
 WF-2042	2.4 GHz	-	-	-	16	Source	700 mA
WF-2051		16	Dry / Wet	Dry: Source Wet: Sink/ Source	-	-	-
WF-2055		8			8	Sink	700 mA
WF-2060		6			6	Relay (Form A)	5 A
 WF-2251	2.4 / 5 GHz	16			-	-	-
WF-2255		8	8	Sink	700 mA		
WF-2260		6	6	Relay (Form A)	5 A		
 tWF-PD4R3	2.4 GHz	4	Dry	Sink	3	Relay (Form A)	5 A
tWF-PD4SR2A		4			2	AC SSR	1.5 A
tWF-PD4SR2D		4			2	DC SSR	1 A
tWF-PD8		8			-	-	-
tWF-R6		-			-	-	6

 **Wi-Fi Multifunction I/O**

Model	Freq.	AI		AO		DI		DO	
		CH.	Type	CH.	Type	CH.	Type	CH.	Type
 WF-2026	2.4 GHz	5	0 ~ +20 mA, +4 ~ +20 mA, ±20 mA, ±150 mV, ±500 mV, ±1 V, ±5 V, ±10 V	2	0 ~ +5 V, 0 ~ +10 V, ±5 V, ±10 V, 0 ~ +20 mA, +4 ~ +20 mA	2	Dry (Source)	3	Sink
 WF-2226	2.4 / 5 GHz	5		2		2		3	
 tWF-DA1PD2R	2.4 GHz	-	-	1	0 ~ +10 V, 0 ~ +20 mA	2		1	Relay (Form A)

7.3.2 ZigBee Modules

ZigBee is a wireless network protocol that is developed for automation-orientation. Based on WPAN (Wireless Personal Area Network), the IEEE802.15.4 network regular can operate under ISM wireless frequency and organized as a universal, low cost, self-organizing mesh network which can apply in fields such as Industrial Control, Embedded Sensing, Medical Data Acquisition, Toxic gas monitoring and personnel intrusion alarm, and Building / Home Automation.



Type of ZigBee Devices

❖ ZigBee Coordinator (Master):

Only one Coordinator in a ZigBee network. The coordinator is responsible for initiating and managing the network. It assigns addresses to devices, and maintains information about the network topology.

❖ ZigBee Router (Slave):



Router can be used as a repeater while in operating. The main function is to transmit and transfer data between devices.

❖ ZigBee End Device (Slave):

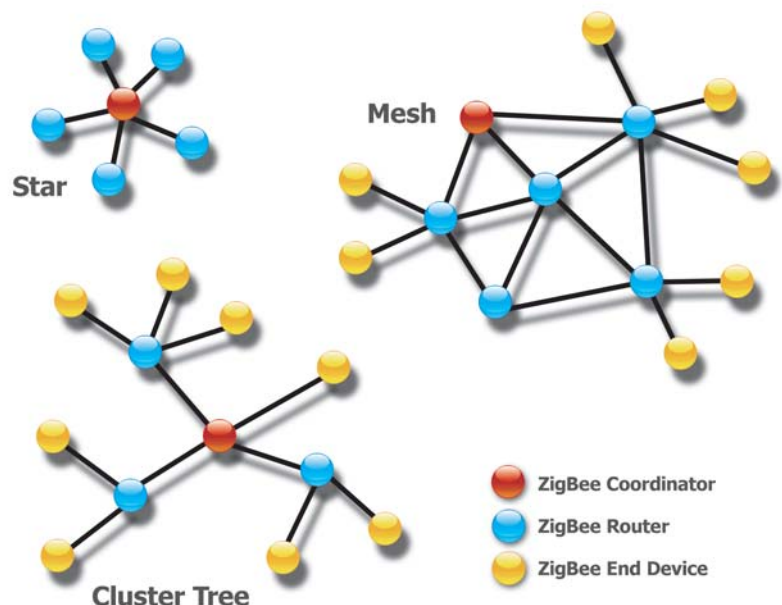
This type of devices communicates with the parent node (including coordinator, router) with the most streamlined functions.



ZigBee I/O Modules Comparison Table

Product Line	ZT-2000	ZT-2000-IOG	ZT-2000-IOP
Pictures			
Antenna / LOS	2.4 GHz, 5 Omni-Directional / 700 m		
Standard	ZigBee 2007 Pro		
Module Type	Slave (Router)	Full Function (Coordinator / Router)	Host (Coordinator)
Pair Connection	No	Yes	Yes
Protocol	DCON / Modbus RTU	-	-

Applications:

ZigBee is a low-power wireless communication technology that was developed for use in industrial automation control. It is based on the IEEE 802.15.4 standard, which specifies the physical and media access control layers for wireless personal area networks (WPANs). ZigBee technology is widely used in automation systems, such as smart lighting, climate control, and security systems, as well as in industrial and commercial applications, such as monitoring and control of machines and equipment.

Street Lamp Monitoring System

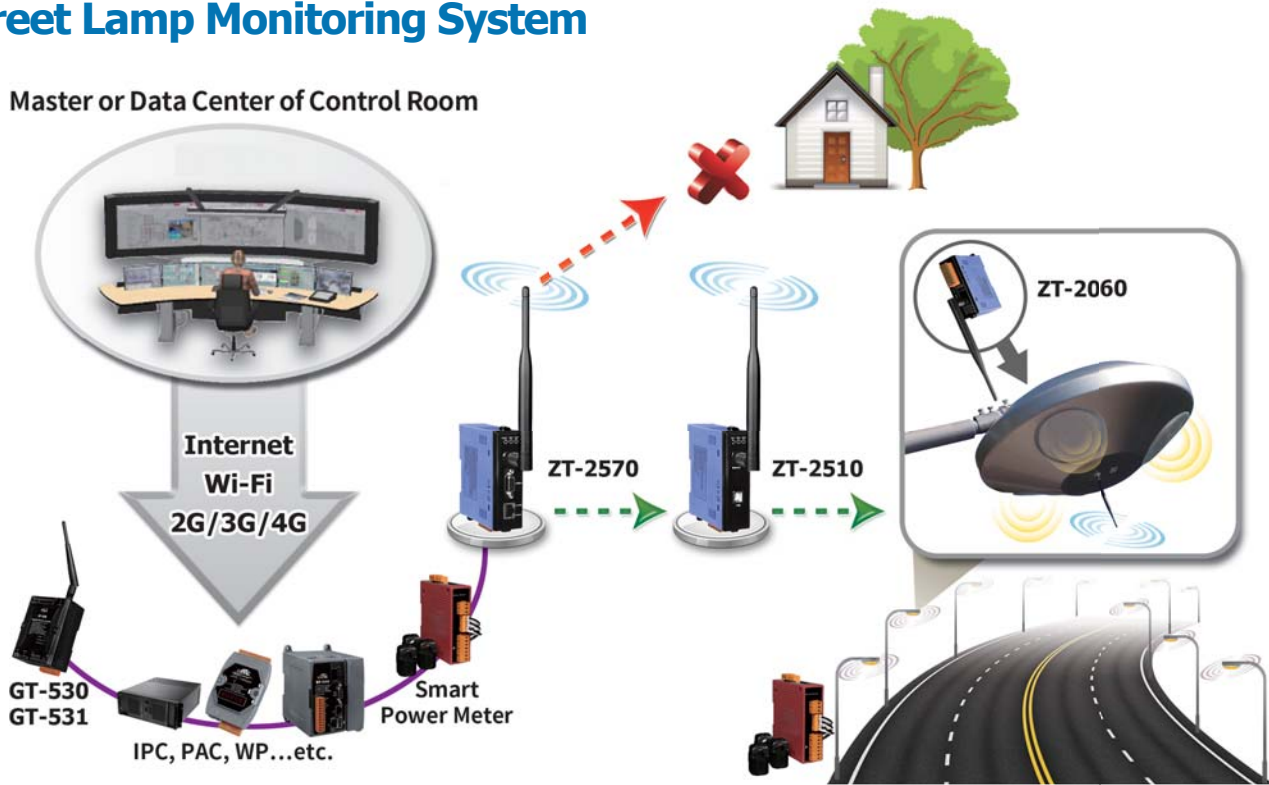



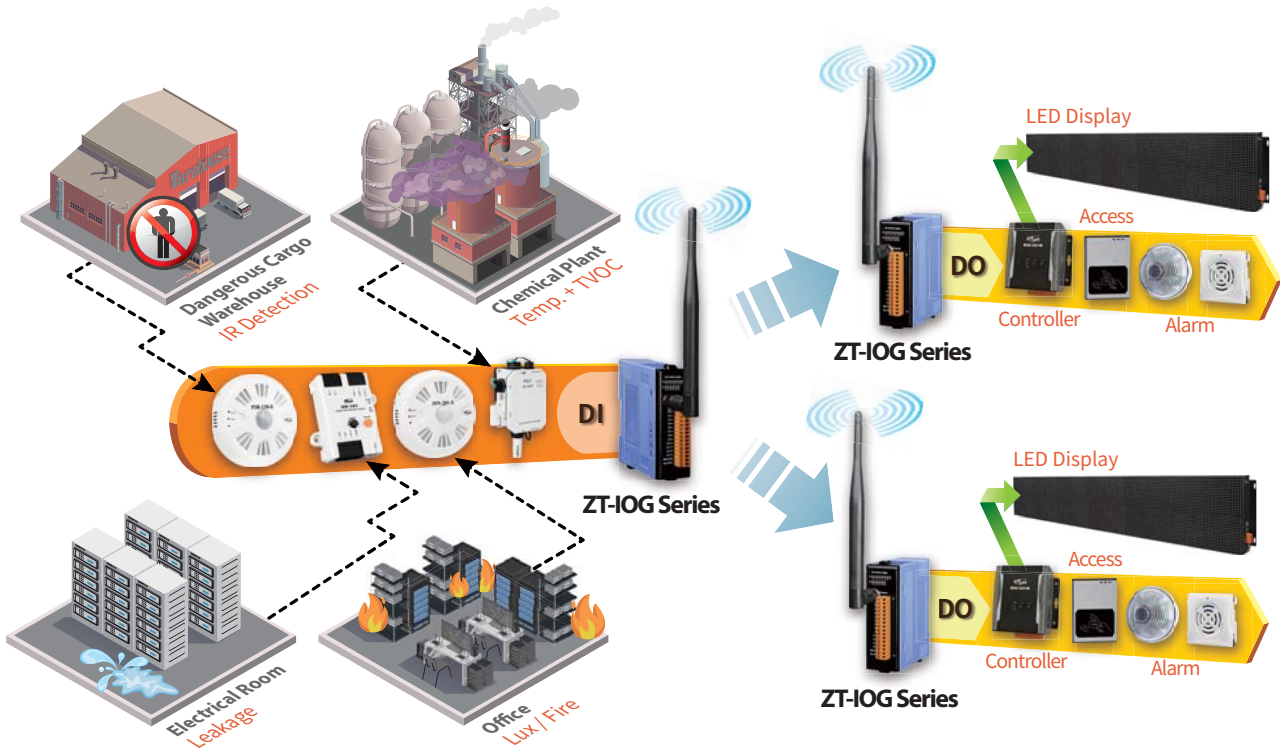

Environmental Monitoring System





Selection Guides:

ZigBee Analog I/O (Router)

Model		Analog Input			Analog Output	
		CH.	Input Range	Sensor	CH.	Output Range
	ZT-2005-C8	8	-40 ~ +105 °C	10 K Thermistor	-	-
	ZT-2015	6	-	Pt100, Pt1000, Ni120, Cu100, Cu1000	-	-
	ZT-2017	8	±10 V, ±5 V, ±1 V, ±500 mV, ±150 mV, ±20 mA	-	-	-
	ZT-2017C	8	±20 mA, 0 ~ +20 mA, +4 ~ +20 mA	-	-	-
	ZT-2018/S	8	±15mV, ±50mV, ±100mV, ±500mV, ±1V, ±2.5V, ±20mA, 0~20mA, 4~20mA	Thermocouple(J, K, T, E, R, S, B, N, C, L, M, LDIN43710)	-	-
	ZT-2024	-	-	-	4	0 ~ +5 V, ±5 V, 0 ~ +10 V, ±10 V, 0 ~ 20 mA, 4 ~ 20 mA





ZigBee Digital I/O (Router)

Model		Digital Input / Counter			Digital Output		
		CH.	Contact	Sink / Source	CH.	Type	Max. Load
	ZT-2042	-	-	-	4	Relay (Form A)	5 A
		-	-	-	4	Sink	700 mA
	ZT-2043	-	-	-	14	Sink	700 mA
	ZT-2052	8	Wet	Sink / Source	-	-	-
ZT-2053	14	Dry / Wet	-		-	-	
ZT-2055	8	Dry / Wet	8		Sink	650 mA	
ZT-2060	6	Wet	4		Relay	5 A	
	tZT-P4C4	4	Wet	Source	4	Sink	700 mA





 ZigBee Multifunction I/O (Router)

Model	Module Type	AI		AO		DI		DO	
		CH.	Type	CH.	Type	CH.	Type	CH.	Type
 ZT-2026	Router	4	±10 V, ±5 V, ±1V, ±500 mV, ±150 mV, ±20 mA	2	0 ~ +5 V, 0 ~ +10 V, ±5 V, ±10 V	2	Wet (Sink)	2	Sink

 ZigBee Digital I/O (Full Function)

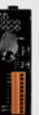
Model	Digital Input / Counter			Digital Output		
	CH.	Contact	Sink / Source	CH.	Type	Max. Load
 ZT-2043-IOG	-	-	-	14	Sink	700 mA
 ZT-2053-IOG	14	Dry / Wet	Sink / Source	-	-	-
 ZT-2055-IOG	8	Dry / Wet	Sink / Source	8	Sink	700 mA
 ZT-2060-IOG	6	Wet	Sink / Source	4	Relay	5 A

 ZigBee Digital I/O (Coordinator)

Model	Digital Input / Counter			Digital Output		
	CH.	Contact	Sink / Source	CH.	Type	Max. Load
 ZT-2052-IOP	8	Wet	Sink / Source	-	-	-
 ZT-2053-IOP	14	Dry / Wet	Sink / Source	-	-	-
 ZT-2055-IOP	8	Dry / Wet	Sink / Source	8	Sink	700 mA
 ZT-2060-IOP	4	Wet	Sink / Source	4	Relay	5 A

7.3.3 RF Modules

RFU-IO is a RF wireless I/O unit that uses the Modbus communication protocol. It can be equipped with an ICPDAS XV series I/O module. A remote Modbus master can use a wireless converter to convert Modbus commands into RF signals to control the I/O module on the RFU-IO, thereby implementing a wireless I/O solution.

RF Module Communication Advantages

Flexible Diffraction

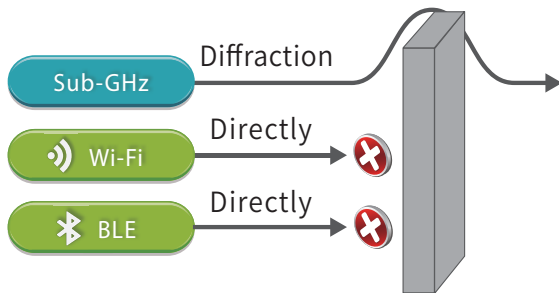

Low-Interference Frequency

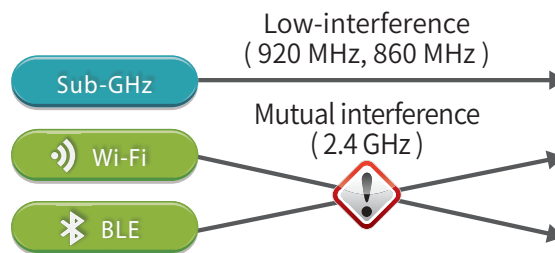

Good Transmissibility

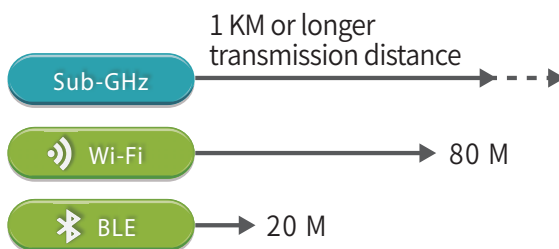

Low Power Consumption

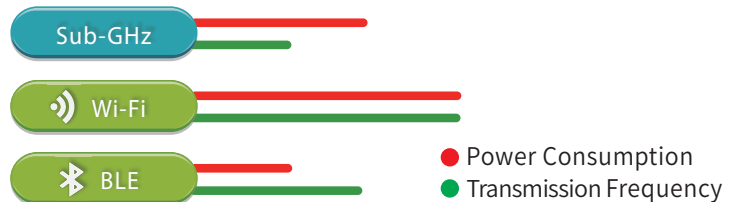

Application:

Using the Pair-connection mode of RFU-IO-433, the DI status point of the remote device can trigger the DO of the paired RFU-IO-433 to output simultaneously, and display the real-time status of the device on the display panel in the monitoring room. The user can handle the situation by reading the information on the display panel and realize remote monitoring.

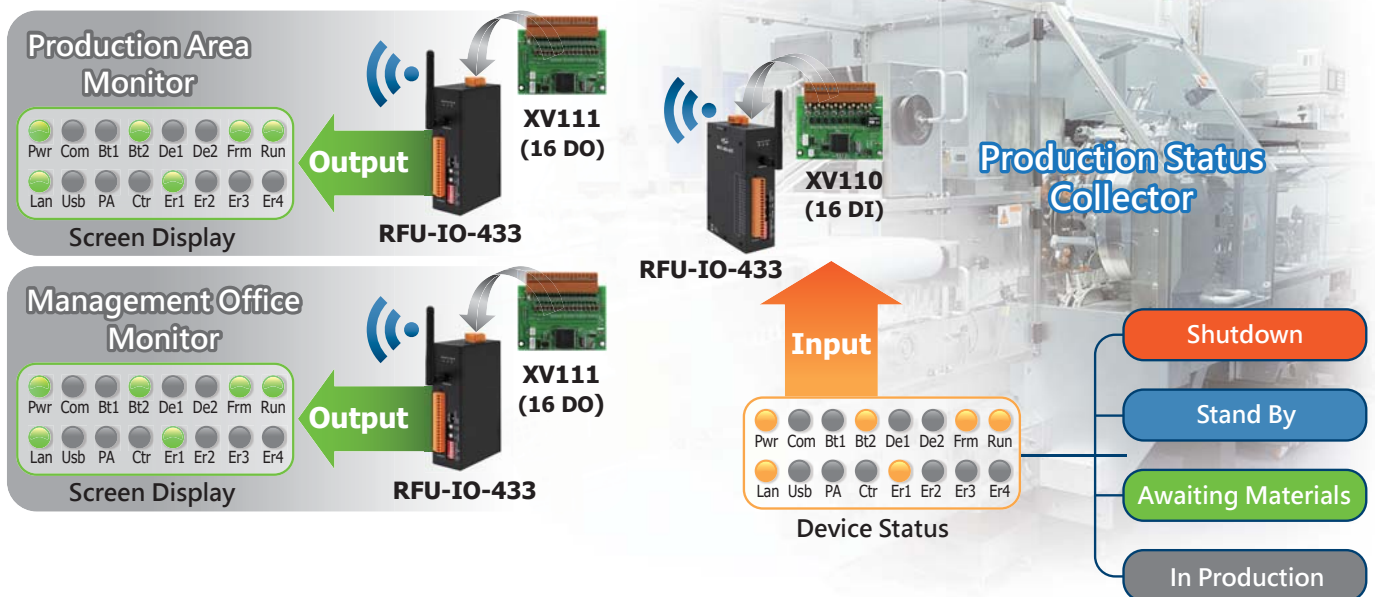

Selection Guides:

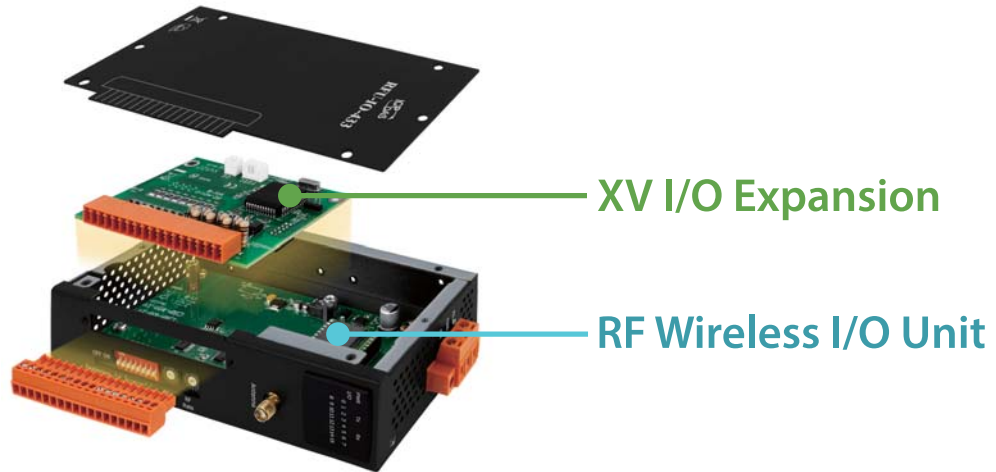

✓ RF I/O Unit

Model	RFU-IO-433	RFU-IO-920
Radio Frequency	433.1 MHz ~ 434.6 MHz	920 MHz ~ 925 MHz
Transmission Distance (LoS)	300 m	
Baud Rate	5 k ~ 500 kbps	
Channels / Group ID	16 / 0 ~ 3	
Protocol	Modbus RTU	

✓ XV Digital I/O Expansion Boards

Model	Connection Mode	Digital Input			Digital Output	
		CH.	Type	Sink / Source	CH.	Type
XV107	Normal & Pair	8	Wet	Source	8	Sink
XV107A		8		Sink	8	Source
XV110		16	Dry/Wet	Sink/Source	-	-
XV111		-	-	-	16	Sink
XV111A		-	-	-	16	Source
XV116		5	Wet	Sink/Source	2/4	Signal Relay / Power Relay

✓ XV Multifunction I/O Expansion Boards

Model	Module Type	AI		AO		DI		DO	
		CH.	Type	CH.	Type	CH.	Type	CH.	Type
XV303	Normal & Pair	-	-	4	0 ~ +5 V, 0 ~ +10 V, ±5 V, ±10 V, 0 ~ +20 mA, +4 ~ +20 mA	4	Wet	4	Relay (Form A)

Model	Module Type	AI		AO		DI		DO	
		CH.	Type	CH.	Type	CH.	Type	CH.	Type
XV305	Normal & Pair	4	±1 V, ±2.5 V, ±15 mV, ±20 mA, 0 ~ +20 mA, +4 ~ +20 mA, ±50 mV, ±100 mV, ±500 mV Thermocouple: J, K, T, E, R, S, B, N, C	-	-	4	Wet	4	Relay (Form A)
XV306		4	±1 V, ±2.5 V, ±5 V, ±10 V, ±20 mA, 0 ~ +20 mA, +4 ~ +20 mA	-	-				
XV307		-	-	-	0 ~ +5 V, ±10 V, 0 ~ +10 V, ±5 V, 0 ~ +20 mA, +4 ~ +20 mA				
XV308	Normal	8	±1 V, ±2.5 V, ±5 V, ±10 V, ±20 mA, 0 ~ +20 mA, 4 ~ +20 mA	-	-	8*	Dry / Wet	8	Sink (NPN)
XV310	Normal & Pair	4		2	0 ~ +5 V, ±10 V, 0 ~ +10 V, ±5 V, 0 ~ +20 mA, +4 ~ +20 mA	4	Dry	4	Source (PNP)
XV315	Normal	3	RTD: Pt100, Pt1000, Ni120, Cu50, Cu100, Cu1000	3	0 ~ +10 VDC, 0 ~ +20 mA, +4 ~ +20 mA	4**	Wet	-	-

Note: * Universal Digital Input and Digital Output=8 (By Wire Connection)
** Supports 3 kHz counter

XV Digital I/O Expansion Boards

Model	Connection Mode	CH.	Encoder	Counter	Frequency	Resolution	Max. Counting Rate
XV484	Normal	4/8	CW/CCW, Dir/Pulse	Up, Up/Down	Yes	32-bit	200 kHz

XV Digital I/O Expansion Boards

Model	Connection Mode	CH.	Type	Output	Load	Sink/Source	Max. Rate
XV488	Normal	4/8	PWM	Internal Power	+5 VDC	Sink, Source	500 kHz
				External Power	+3.5 ~ +50 VDC	Sink	



IloT 1 Software . Controller / Server

- Cloud Management Software: IoTstar
- SCADA System Software: AVEVA Edge
- Condition Monitoring Solution: ExoWISE
- Edge Controller WISE Series:
- Communication Server: UA Series
- MQTT Communication Server: BRK Series



IloT 3 Environmental Monitoring / Mini Weather Station

- Smart Environmental Monitoring: CL Series
- Air Box: DL Series
- Mini Weather StationMotion: DLW Series
- Detector: PIR Series
- Industrial Sensor Network Detection: iSN Series
- Wireless Environmental Solution: iWSN/iXN/iSOS Series

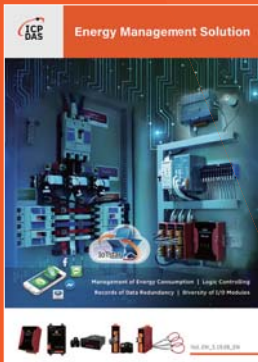

Energy Management Solution

- InduSoft SCADA Software
- Smart Power Meter Concentrator
- Smart Power Meter
- True RMS Input Module
- TouchPAD Devices - VPD Series



Industrial Fieldbus

- RS-485
- Industrial Ethernet
- Profinet
- CAN bus
- CANopen
- DeviceNet
- J1939
- PROFIBUS
- HART
- EtherNet/IP
- BACnet



ZigBee Wireless Product Solutions

- ZigBee Wireless Network Applications
- ZigBee Converters
- ZigBee Repeater
- ZigBee Bridge
- ZigBee I/O Group Module
- ZigBee I/O Module
- ZigBee Modbus Data Concentrator
- Accessories



UA Series / BRK Series: IloT Cloud Solution

- IloT Cloud Solution Products
- IloT Communication Server: UA-2000/5000/7000 Series
- MQTT Communication Server: BRK-2000 Series
- OPC UA I/O Module: U-7000 Series



WISE - Intelligent IloT Edge Controller & I/O Module

- WISE IloT Edge Controller & I/O Module
- Cloud Management Applications
- Product Specification
- Solution Integration



Smart Building, Smart Home Automation

- Video Intercom & Access Control
- Touch HMI - TouchPAD Series
- Smart Lighting Control
- Energy Saving - PM/PMC Series
- Environmental - DL/CL Series
- Motion Detector - PIR Series
- Wi-Fi Wireless - WF Series
- Infrared Wireless - IR Series
- ZigBee Wireless - ZT Series
- IloT Server & Concentrator
- LED Display - iKAN Series



Headquarters in Taiwan (Hsinchu)

+886-3-597-3366

ICP DAS CO., LTD.

info@icpdas.com / sales@icpdas.com



www.icpdas.com