



Industrial Communication & Networking Products Catalog

Vol. ICNP 2.0.00

ICP DAS

Industrial Communication & Networking Products Catalog

Vol. ICNP 2.0.00





Table of Contents

1 Introduction

- ▶ 1-1 Industrial Communication & Networking Products -----1-1-1

2 Multi-port Serial Cards

- ▶ 2-1 Overview -----2-1-1
- ▶ 2-2 Serial Communication Cards -----2-2-1
- ▶ 2-3 Applications -----2-3-1

3 Serial Device Server

- ▶ 3-1 Overview -----3-1-1
- ▶ 3-2 Palm-size Programmable Serial-to-Ethernet Device Server --3-2-1
- ▶ 3-3 Palm-size Serial-to-Ethernet Device Server -----3-3-1
- ▶ 3-4 IP67 Programmable Serial-to-Ethernet Device Server -----3-4-1
- ▶ 3-5 Modular Programmable Serial-to-Ethernet Device Server ---3-5-1
- ▶ 3-6 Programmable Serial-to-Fiber Device Server -----3-6-1
- ▶ 3-7 Tiny Serial-to-Ethernet Device Server & Modbus Gateway --3-7-1
- ▶ 3-8 Programmable Serial Device Server with LAN Switch -----3-8-1
- ▶ 3-9 Programmable Modbus to Ethernet Gateway -----3-9-1

4 Converters, Repeaters, Hubs and Splitter

- ▶ 4-1 RS-485 Network Configuration -----4-1-1
- ▶ 4-2 RS-422/485 Repeaters -----4-2-1
- ▶ 4-3 RS-485 Repeater/Hub/Splitter -----4-3-1
- ▶ 4-4 RS-232/422/485 Converters -----4-4-1
- ▶ 4-5 Intelligent Communication Controllers -----4-5-1
- ▶ 4-6 USB to RS-232/422/485 Converters -----4-6-1
- ▶ 4-7 RS-232/422/485 to Fiber Optic Converter -----4-7-1

5 Fieldbus Solutions

- ▶ 5-1 Overview -----5-1-1
- ▶ 5-2 CAN Bus Introduction & Products -----5-2-1
- ▶ 5-3 CANopen Introduction & Products -----5-3-1
- ▶ 5-4 DeviceNet Introduction & Products -----5-4-1
- ▶ 5-5 J1939 Introduction & Products -----5-5-1
- ▶ 5-6 PROFIBUS Introduction & Products -----5-6-1
- ▶ 5-7 HART Introduction & Products -----5-7-1
- ▶ 5-8 EtherNet/IP Introduction & Products -----5-8-1
- ▶ 5-9 BACnet Introduction & Products -----5-9-1

6 Ethernet Switches

- ▶ 6-1 Overview -----6-1-1
- ▶ 6-2 Product Showcase -----6-2-1

7 Accessories

- ▶ 7-1 Cables -----7-1-1
- ▶ 7-2 Power Supplies -----7-2-1
- ▶ 7-3 Terminal Boards & Connector -----7-3-1

8 Wireless Networking Solutions

- ▶ 8-1 Overview -----8-1-1
- ▶ 8-2 WLAN Products -----8-2-1
- ▶ 8-3 DSSS RF Products -----8-3-1
- ▶ 8-4 2G/3G Products -----8-4-1
- ▶ 8-5 ZigBee Products -----8-5-1
- ▶ 8-6 GPS Products -----8-6-1
- ▶ 8-7 Infrared Products -----8-7-1
- ▶ 8-8 Wireless Applications -----8-8-1

Trademark

The trademarks, trade names, logos, service marks and the product names ("Marks") mentioned in this document are properties of ICP DAS or other third parties. The user is not permitted to use the Marks without the prior written consent of ICP DAS or such third parties which may own the Marks.

Introduction

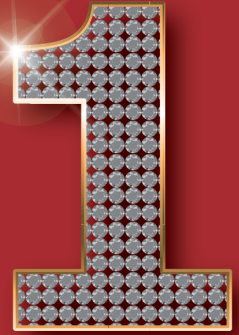

1-1 Industrial Communication & Networking Products -----1-1-1

- RS-485 Bus Repeater, Converter and Hub -----1-1-1
- USB to RS-232/422/485/CAN Bus Converters -----1-1-2
- Multi-port RS-232/422/485 Communication Cards -----1-1-2
- Programmable Serial to Ethernet Device Server -----1-1-2
- Ethernet Switch -----1-1-2
- Fieldbus in Industrial Automation -----1-1-3



1-1 Industrial Communication & Networking Products

1

1

Introduction



<p>I-7540D Ethernet to CAN Bus Converter</p> 	<p>PDS-700 Serial to Ethernet Gateway</p> 	<p>VXC-114U/D2 Multi-port Serial Card</p> 	<p>I-7520/7520A RS-232 to RS-485 Converter</p> 	<p>tM-7561 USB to Isolated RS-485 Converter</p> 	<p>I-7530A Serial to CAN Bus Converter</p> 
---	--	--	---	--	---

• Multi-port RS-232/422/485 Communication Cards



The VXC/VEX series card features Universal PCI (3.3 V and 5 V) or PCI Express interface, provides multiple RS-232 or RS-422/485 communication ports and offers 128-byte hardware FIFO for each port. The VXC/VEX series card enables user to install additional communication ports on PCs, and supports 32-bit and 64-bit Windows 7/Vista/2003/XP. Users can select a specified COM port number manually by setting COM-Selector (DIP switch), or let the driver to choose an available number automatically.

It's the best choice for time-critical and reliable communications and controls in industrial environments, like communication with PLC, machine, meter, console management of devices, laboratory instruments and Modem link, etc.

Chapter 2

• Programmable Serial to Ethernet Device Server



Programmable Device Server (PDS) is Serial-Device to Ethernet gateway. It connects RS-232/422/485 serial devices, such as PLC, bar code reader, RFID reader, meters and motion controllers... etc., to Ethernet that usually is the existing network in office and factory.

VxComm Driver creates virtual COM ports on 32-bit and 64-bit Windows 7/Vista/2003/XP and maps them to physical serial ports on PDS remotely. User's serial programs need only to change to the virtual COM port to get the access of serial devices that are allocated in the Internet or Ethernet network via the PDS.

Chapter 3

• Repeater, Converter, Splitter and Hub



RS-485 is an electrical specification of a two-wire, half-duplex and multipoint serial communications channel. Since it uses a differential balanced line over twisted pair (like RS-422), it can span relatively long distances (up to 4,000 feet (1,200 m)). RS-485 is widely used in the computer automation systems, such as building automation, machine automation and factory automations etc. Used for low cost low-speed data communications, it requires minimal wiring, and shares the wiring among several nodes.

ICP DAS provides total solutions on RS-485 bus, such as addressable RS-485 to RS-232/422 converter, RS-485 repeater, RS-232 to RS-485 converter, USB to RS-485 converter, RS-232/422/485 to fiber optic converter and RS-485 Hub... etc.

Chapter 4

• USB to RS-232/422/485/CAN Bus Converters



Universal Serial Bus (USB) is designed to allow many peripherals to be connected by using a single standard interface socket, and to improve the plug-and-play capabilities by hot swapping. In brief, devices can be connected and/or disconnected without rebooting the computer or turning off the device.

Currently USB ports are standard interface to external devices on many computers. By using ICP DAS USB converters, users can access industrial RS-232/422/485 serial devices and CAN bus devices through the existing USB ports easily.

Chapter 4

• Ethernet Switch



Ethernet is an ideal medium to transport large volumes of data, at fast speed, across great distances. Previously, multiple networks carrying specific protocols were installed side by side to carry out unique tasks. This inevitably led to project costs increasing as additional fiber optic or copper cables were installed to deal with the increasing volume of data. Using Ethernet, a single fiber optic cable can carry multiple protocols.

A switch, like a hub, has to forward and receive packets from one network or device to another. The switch forwards all packets, but if this is the case it shall have similar behavior to a hub. It becomes more intelligent if the switch only forwards packets which needs to travel from one network or device to another.

Chapter 6

• **Fieldbus in Industrial Automation**

Fieldbus is an industrial network system for real-time distributed control. It is a way to connect instruments in a manufacturing plant. Fieldbus works on a network structure which typically allows daisy-chain, star, ring, branch, and tree network topologies. Fieldbus reduces both the length and the number of cables required. Fieldbus has many major advantages to all applications of automation. The technology of fieldbus is mature and well accepted in various fields in markets. ICP DAS has focused on these fieldbus products for several years and offers various fieldbus solutions in different industrial applications, covering the entire scope of process and manufacturing automation: CAN bus, CANopen, DeviceNet, J1939, PROFIBUS, HART, EtherNet/IP and BACnet applications



ICP DAS's Fieldbus Development Services group has been involved in the design and development of industrial fieldbus and industrial Ethernet products for several years. Besides providing the various fieldbus products, the rich experience and expertise helps the customer to arrange the proper system architecture and to solve the problems occurred during setting up a system. By using the certified IC and certification tool, all products are reliable and compatible with other manufacturers' products.

Chapter 5

• **Wireless Networking**



Industrial Wireless Communication creates new prospects for automation. In the harsh environment, chemicals, vibrations, or moving parts could potentially damage cabling. Industrial Wireless Communication system substantially reduces cost and time for the installation and maintenance of the large number of cable, thus makes plants setup and reconfiguration easy and safe.

ICP DAS provides a great variety of wireless products with modular and universal solution specially designed for industrial harsh environment.

Chapter 8

Multi-port Serial Cards



2-1 Overview	-----	2-1-1
2-2 Serial Communication Cards	-----	2-2-1
2-3 Applications	-----	2-3-1

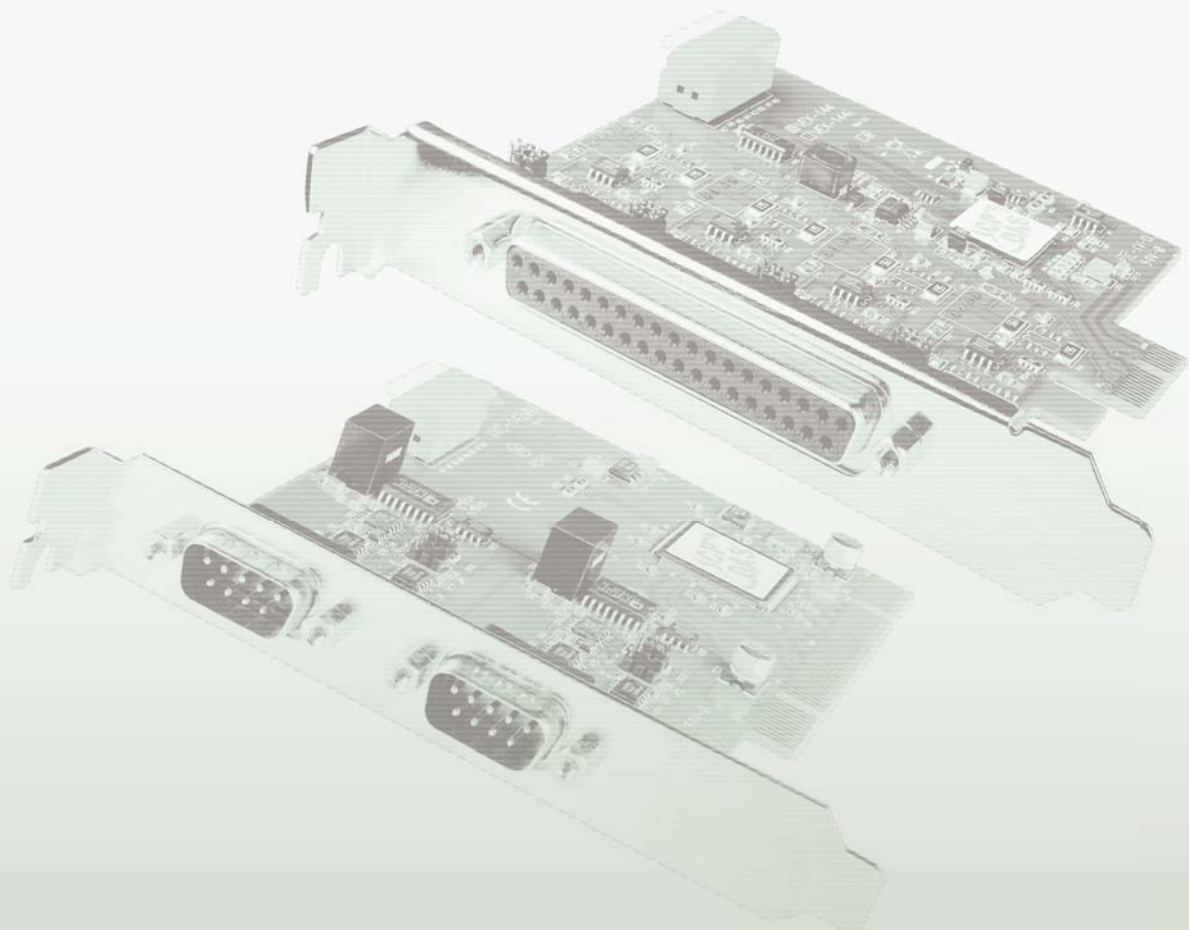

2-1 Overview

2

1

Multi-port Serial Cards

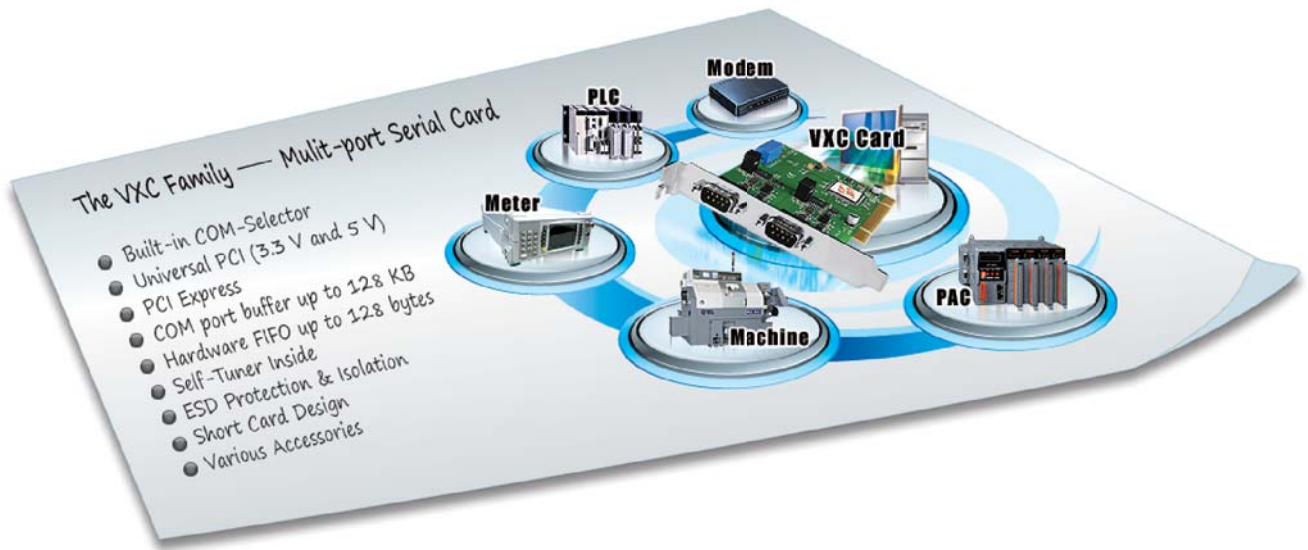

• Overview

The VXC/VEX multi-port serial card enables user to increase additional communication ports on PCs. It's the on-top-of-the-list choice while you are managing to connect lots of outer devices through your PC; every VXC/VEX card ensures you smooth communication in both time-critical applications and industrial fields. With simply a VXC card, it has never been that easy to integrate a PC with lots of devices, such as PLCs, machines, meters, controller devices, laboratory instruments, modems, card readers, serial printers, RFID readers, bar code readers, sensors, etc.

• Features

COM-Selector

Each VXC/VEX card is equipped with a COM-Selector (DIP switch) for the COM port number selection. It supports two selection modes: Auto- and Manual-mode. The Auto-mode is the default setting (DIP switch is set as 0), and the uncertain COM port number will be assigned automatically by OS. The COM port number can be different after the PC reboot, and then may cause failures of an automation system. The Manual-mode of the COM-selector (DIP switch is set as 1 ~ 255) can force the card to use user-defined COM port number and eliminates the Auto-mode issues above. It's an important and innovative feature of the VXC/VEX family.

The Manual-mode of the COM-Selector provides the following advantages:

- Simplifies the COM port number selection without configuration utility.
- Specifies the COM port number directly, regardless of which PCI slot is plugged in.
- Avoids the confusion of uncertain COM port number that other PnP COM port devices use.
- Easy to replace a broken card just with the same DIP switch setting.



Easy COM Port Selection by DIP switch

ESD Protection

The VXC/VEX cards offer TVS diode ESD protection technology, protecting your system from being damaged by the high potential voltages.

Under normal operating conditions, the TVS diode presents high impedance (appears as an open circuit) to the protected component. When the voltage is beyond the limits, the TVS diode junction avalanches providing a low impedance path for the transient current. As a result, the transient current is diverted away from the protected components and shunted through the TVS diode. The device returns to a high impedance state after the transient threat passed.

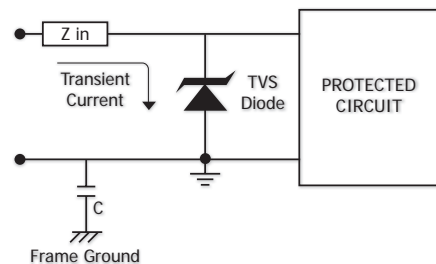

Self-Tuner

The VXC/VEX card is equipped with a "Self-Tuner" chip to control the sending/receiving direction of RS-485 ports automatically.

Without the help of Self-Tuner, users need to enable RS-485 transmitter before sending, and disable the transmitter after finish sending. The timing to enable and disable transmitter (direction control) is the major issue on many communication problems, and it is very difficult to debug.

The built-in Self-Tuner on VXC/VEX cards effectively gets rid of this direction control issue and also simplifies software programming for communication applications.

Isolation

Some VXC/VEX cards offer photo isolation to protect your computer and equipment against damages in harsh environment.

Photo coupler is a device that uses a short optical transmission path to transfer a signal between elements of a circuit, typically a transmitter and a receiver. This keeping them electrically isolated — since the signal goes from an electrical signal to an optical signal, the electrical contact along the path is broken.

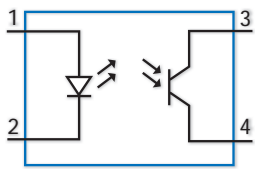
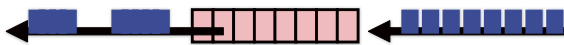

Photo Coupler Operation

It can help cutting down on ground loops, common mode voltages and block voltage spikes, provide electrical isolation, and offer significant protection from serious over-voltage conditions in one circuit affecting the other.

Hardware FIFO up to 128 bytes

FIFO stands for "First In, First Out", an abstraction in ways of organizing and manipulating data relative to time and prioritization. FIFO is used for buffering and flow control while data come from hardware to software. When using hardware FIFO (buffer), a little delay on software or operating system will not lose data at all.



Software gets data in dynamic timing.

Hardware puts data in fixed speed.

VXC/VEX Cards are equipped with 16- or 128-byte hardware FIFO for each port. Large hardware FIFO is useful to prevent data lost when your system works on heavy loading, and even helpful while you are running on a multi-task operating system, such as Windows, Linux... etc.

COM port buffer up to 128 KB

The VXC card driver for Windows features an up to 128 KB buffer for each port (default is 4 KB). It's practical for large file transmission.

Short Card Design

The "Short Card" design is suitable for compact-sized computer, especially for IPC (Industrial Personal Computer) and servers.

Universal PCI (3.3 V and 5 V)

The Universal PCI card works with both new 3.3 V PCI bus that has been widely-used in servers, and traditional 5 V PCI bus. The universal PCI interface will be the standard for every card from ICP DAS in the near future.

PCI Express

PCI Express (PCIe) is a computer expansion bus standard. A key difference between PCIe and earlier PC buses is a topology based on point-to-point serial links, rather than a shared parallel bus architecture. Conceptually, the PCIe bus can be thought of as a 'high-speed serial replacement' of the older PCI/PCI-X bus.

Various Accessories

There are a lot of optional accessories for the VXC/VEX cards, such as RS-232 cables and daughter boards. These tools make wiring much easily than ever.



DB-9 Cable



DB-9 Daughter Board



DB-9 Cable



DB-37 to 4-port DB-9 Cable



DB-37 Connector



DB-9 Connector

• Wiring Note for RS-232 and RS-422/485 Devices

RS-232 Wiring

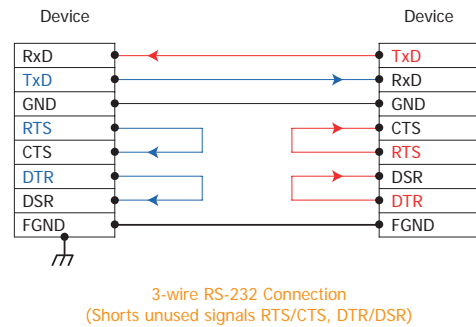
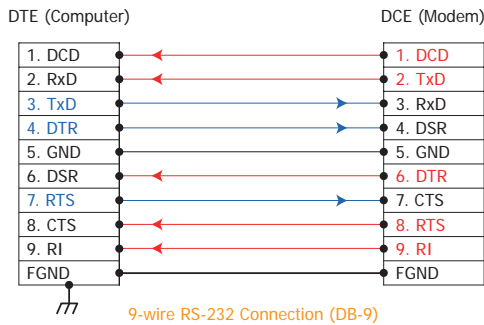

Note:

1. For 3-wire RS-232 connections, it is recommended to short unused signals such as RTS/CTS and DTR/DSR, since some systems may still check the CTS and DSR status.
2. FGND is the frame ground that soldered to DB-9 metal shield.

RS-485 Wiring

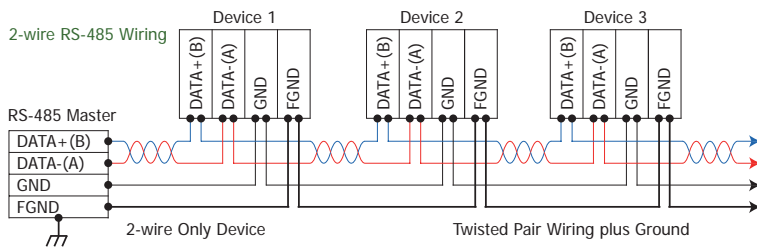

RS-422 Wiring

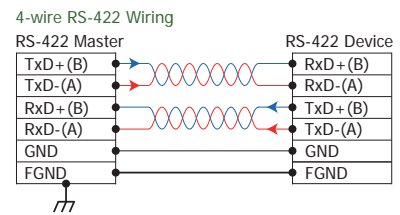

Note:

1. For non-isolated RS-422/485 ports, you should connect all signal grounds of RS-422/485 devices together. This reduces common-mode voltage between devices.
2. Twisted-pair cable must be used for the DATA+/- wires.
3. Both two ends of the cable may require a termination resistor connected across the two wires (DATA+ and DATA-). Typically 120 Ω resistors are used.

• Selection Guide



Universal PCI

Model Name	COM-Selector	RS-232	RS-422/485	Self-Tuner	Isolation	ESD Protection	Max. Speed (bps)	FIFO Size (bytes)	Connector	Page
VXC-112AU	Yes	2	–	–	–	–	115.2 K	128	Male DB-9	2-2-1
VXC-112iAU	Yes	2	–	–	2.5 kV	+/-4 kV	115.2 K	128	Male DB-9	2-2-1
VXC-142AU	Yes	–	2	Yes	–	–	115.2 K	128	Male DB-9	2-2-3
VXC-142iAU	Yes	–	2	Yes	2.5 kV	+/-4 kV	115.2 K	128	Male DB-9	2-2-3
VXC-182iU	Yes	1	1	Yes	2.5 kV	+/-4 kV	115.2 K	128	Male DB-9	2-2-5
VXC-114U	Yes	4	–	–	–	–	115.2 K	128	Female DB-37	2-2-2
VXC-114iAU	Yes	4	–	–	2.5 kV	+/-4 kV	115.2 K	128	Female DB-37	2-2-2
VXC-144U	Yes	–	4	Yes	–	–	115.2 K	128	Female DB-37	2-2-4
VXC-144iU	Yes	–	4	Yes	2.5 kV	+/-4 kV	115.2 K	128	Female DB-37	2-2-4
VXC-164AU	Yes	4		Yes	–	–	115.2 K	128	Female DB-37	2-2-6
VXC-118U	Yes	8	–	–	–	–	115.2 K	256	Female DB-62	2-2-7
VXC-118iU	Yes	8	–	–	2.5 kV	+/-4 kV	115.2 K	256	Female DB-62	Call
VXC-148U-5w	Yes	–	8	Yes	–	–	115.2 K	256	Female DB-62	2-2-8
VXC-148iU-5w	Yes	–	8	Yes	2.5 kV	+/-4 kV	115.2 K	256	Female DB-62	Call



PCI Express

Model Name	COM-Selector	RS-232	RS-422/485	Self-Tuner	Isolation	ESD Protection	Max. Speed (bps)	FIFO Size (bytes)	Connector	Page
VEX-112	Yes	2	–	–	–	–	115.2 K	128	Male DB-9	2-2-1
VEX-112i	Yes	2	–	–	2.5 kV	+/-4 kV	115.2 K	128	Male DB-9	2-2-1
VEX-142	Yes	–	2	Yes	–	–	115.2 K	128	Male DB-9	2-2-3
VEX-142i	Yes	–	2	Yes	2.5 kV	+/-4 kV	115.2 K	128	Male DB-9	2-2-3
VEX-114	Yes	4	–	–	–	–	115.2 K	128	Female DB-37	2-2-2
VEX-114i	Yes	4	–	–	2.5 kV	+/-4 kV	115.2 K	128	Female DB-37	2-2-2
VEX-144	Yes	–	4	Yes	–	–	115.2 K	128	Female DB-37	2-2-4
VEX-144i	Yes	–	4	Yes	2.5 kV	+/-4 kV	115.2 K	128	Female DB-37	2-2-4
VEX-118	Yes	8	–	–	–	–	115.2 K	256	Female DB-62	2-2-7
VEX-118i	Yes	8	–	–	2.5 kV	+/-4 kV	115.2 K	256	Female DB-62	Call
VEX-148-5w	Yes	–	8	Yes	–	–	115.2 K	256	Female DB-62	2-2-8
VEX-148i-5w	Yes	–	8	Yes	2.5 kV	+/-4 kV	115.2 K	256	Female DB-62	Call

2-2 Serial Communication Cards

VXC-112AU/VXC-112iAU **NEW**

VXC-112AU/VXC-112iAU

VEX-112/VEX-112i

VEX-112/VEX-112i **NEW**

Serial Communication Card with 2 RS-232 ports



Features ▶▶▶▶

- Built-in COM-Selector
- Provides 2 RS-232 ports
- +/-4 kV ESD Protection for i versions
- Supports PCI Express bus for VEX series
- 128 KB Software Buffer (max.) for Each Port Under Windows
- Short Card Design
- 2500 V_{rms} Isolation for i versions
- Supports 3.3 V/5 V PCI bus for VXC series
- 128-byte Hardware FIFO for Each Port
- RoHS compliant & no Halogen

Hardware Specifications

Models	VXC-112AU	VXC-112iAU	VEX-112	VEX-112i
Communication Port				
COM1, COM2	RS-232 (TxD, RxD, RTS, CTS, DTR, DSR, DCD, RI, GND)			
UART	16C950 compatible			
Baud Rate	50 ~ 115200 bps			
Data Bit	5, 6, 7, 8			
Stop Bit	1, 1.5, 2			
Parity	None, Even, Odd, Mark, Space			
FIFO	Internal 128 bytes			
Isolated	-	2500 V _{rms}	-	2500 V _{rms}
General				
Bus Type	Universal PCI, 3.3 V/5 V, 33 MHz, 32-bit, Plug and Play		PCI Express x1, Plug and Play	
COM-Selector	Yes (8-bit DIP switch)			
Connector	2 x DB-9 (Male)			
Power Consumption	100 mA @ 5 V	480 mA @ 5 V	120 mA @ 5 V	440 mA @ 5 V
Operating Temperature	0 °C ~ +50 °C			
Storage Temperature	-20 °C ~ +70 °C			
Humidity	0 ~ 90% RH, non-condensing			
Dimensions (L x W x D)	134 mm x 90 mm x 22 mm		109 mm x 94 mm x 22 mm	

Software

- Driver for 32-bit and 64-bit Windows XP/2003/Vista/7
- Driver for Linux

Pin Assignments

Pin Assignment	Terminal	No.	Pin Assignment
GND	05	09	RI
DTR	04	08	CTS
TxD	03	07	RTS
RxD	02	06	DSR
DCD	01		

Male DB-9 Connector

Ordering Information

VXC-112AU CR	Universal PCI, Serial Communication Card with 2 RS-232 ports (RoHS)
VXC-112iAU CR	Universal PCI, Serial Communication Card with 2 Isolated RS-232 ports (RoHS)
VEX-112 CR	PCI Express, Serial Communication Card with 2 RS-232 ports (RoHS)
VEX-112i CR	PCI Express, Serial Communication Card with 2 Isolated RS-232 ports (RoHS)

Accessories

CA-0910F	9-Pin Female-Female D-Sub Cable 1 m
CA-0915	9-Pin Male-Female D-Sub Cable, 1.5 m
CA-PC09F	9-Pin Female D-Sub Connector with Plastic Cover
DN-09-2F	I/O Connector Block with DIN-Rail Mounting and Two 9-Pin Male Header. Includes CA-0910F x 2 (9-Pin Female-Female D-Sub Cable 1 m)

VXC-114U/VXC-114iAU **NEW**

VXC-114U/VXC-114iAU

VEX-114/VEX-114i

VEX-114/VEX-114i **NEW**

Serial Communication Card with 4 RS-232 ports



Features ▶▶▶▶

- Supports 3.3 V/5 V PCI bus for U versions
- 128-byte Hardware FIFO for Each Port
- +/-4 kV ESD Protection for i versions
- Supports PCI Express x1 for VEX series
- 128 KB Software Buffer (max.) for Each Port Under Windows
- Built-in COM-Selector
- Short Card Design
- Provides 2 RS-232 ports
- 2500 V_{rms} Isolation for i versions
- RoHS compliant & no Halogen

Hardware Specifications

Models	VXC-114U	VXC-114iAU	VEX-114	VEX-114i
Communication Port				
COM1 ~ COM4	RS-232 (TxD, RxD, RTS, CTS, DTR, DSR, DCD, RI, GND)			
UART	16C950 compatible			
Baud Rate	50 ~ 115200 bps			
Data Bit	5, 6, 7, 8			
Stop Bit	1, 1.5, 2			
Parity	None, Even, Odd, Mark, Space			
FIFO	Internal 128 bytes			
Isolated	-	2500 V _{rms}	-	2500 V _{rms}
General				
Bus Type	Universal PCI, 3.3 V and 5 V, 33 MHz, 32-bit, Plug and Play		PCI Express x1, Plug and Play	
COM-Selector	Yes (8-bit DIP switch)			
Connector	DB-37 (Female)			
Power Consumption	120 mA @ 5 V	880 mA @ 5 V	120 mA @ 5 V	880 mA @ 5 V
Operating Temperature	0 °C ~ +50 °C			
Storage Temperature	-20 °C ~ +70 °C			
Humidity	0 ~ 90% RH, non-condensing			
Dimensions (L x W x D) (Unit: mm)	142 x 84 x 22	133 x 93 x 22	110 x 110 x 22	

Pin Assignments

Pin Assignment	Terminal	No.	Pin Assignment
N.C.	01	20	RI3
DCD3	02	21	DTR3
GND	03	22	DSR3
CTS3	04	23	RTS3
RxD3	05	24	TxD3
RI4	06	25	DCD4
DTR4	07	26	GND
DSR4	08	27	CTS4
RTS4	09	28	RxD4
TxD4	10	29	RI2
DCD2	11	30	DTR2
GND	12	31	DSR2
CTS2	13	32	RTS2
RxD2	14	33	TxD2
RI1	15	34	DCD1
DTR1	16	35	GND
DSR1	17	36	CTS1
RTS1	18	37	RxD1
TxD1	19		

RS-232 Female DB-37 Connector

Pin Assignment	Terminal	No.	Pin Assignment
GND	05	09	RI
DTR	04	08	CTS
TxD	03	07	RTS
RxD	02	06	DSR
DCD	01		

RS-232 Female DB-37 to Male DB-9 Connector

Software

- Driver for 32-bit and 64-bit Windows XP/2003/Vista/7
- Driver for Linux

Ordering Information

VXC-114U CR	Universal PCI, Serial Communication Card with 4 RS-232 ports (RoHS). Includes One CA-4002 Connector
VXC-114U/D2 CR	Universal PCI, Serial Communication Card with 4 RS-232 ports (RoHS). Includes One CA-9-3715D Cable
VXC-114iAU CR	Universal PCI, Serial Communication Card with 4 Isolated RS-232 ports (RoHS). Includes One CA-4002 Connector
VXC-114iAU/D2 CR	Universal PCI, Serial Communication Card with 4 Isolated RS-232 ports (RoHS). Includes One CA-9-3715D Cable
VEX-114 CR	PCI Express, Serial Communication Card with 4 RS-232 ports (RoHS). Includes One CA-4002 Connector
VEX-114/D2 CR	PCI Express, Serial Communication Card with 4 RS-232 ports (RoHS). Includes One CA-9-3715D Cable
VEX-114i CR	PCI Express, Serial Communication Card with 4 Isolated RS-232 ports (RoHS). Includes One CA-4002 Connector
VEX-114i/D2 CR	PCI Express, Serial Communication Card with 4 Isolated RS-232 ports (RoHS). Includes One CA-9-3715D Cable

Accessories

CA-4002	37-Pin Male D-Sub Connector with Plastic Cover
CA-9-3715D	Male DB-37 to 4-port Male DB-9 Cable, 1.5 M (180°)
CA-9-3705	Male DB-37 to 4-port Male DB-9 Cable, 0.3 M (90°)

2

2

Multi-port Serial Cards

VXC-142AU/VXC-142iAU **NEW**

VXC-142AU/VXC-142iAU

VEX-142/VEX-142i

VEX-142/VEX-142i **NEW**

Serial Communication Card with 2 RS-422/485 ports



Features ▶▶▶▶

- Built-in COM-Selector
- Provides 2 RS-422/485 ports
- +/-4 kV ESD Protection for i versions
- Supports 3.3 V/5 V PCI bus for U versions
- RoHS compliant & no Halogen
- Supports pull-high/-low jumpers on RS-485 port
- Short Card Design
- 2500 V_{rms} Isolation for i versions
- 128-byte Hardware FIFO for Each Port
- Supports PCI Express bus for VEX series
- Automatic RS-485 Direction Control

Hardware Specifications

Models	VXC-142AU	VXC-142iAU	VEX-142	VEX-142i
Communication Port				
COM1, COM2	RS-422/485	The RS-422 and RS-485 cannot be used simultaneously		
	RS-422	TxD+, TxD-, RxD+, RxD-, RTS+, RTS-, CTS+, CTS-, GND		
	RS-485	Data+, Data-, GND (Automatic RS-485 Direction Control)		
UART	16C950 compatible			
Baud Rate	50 ~ 115200 bps			
Data Bit	5, 6, 7, 8			
Stop Bit	1, 1.5, 2			
Parity	None, Even, Odd, Mark, Space			
FIFO	Internal 128 bytes			
Isolated	-	2500 V _{rms}	-	2500 V _{rms}
General				
Bus Type	Universal PCI, 3.3 V and 5 V, 33 MHz, 32-bit, Plug and Play		PCI Express x1, Plug and Play	
COM-Selector	Yes (8-bit DIP switch)			
Connector	2 x Male DB-9			
Power Consumption	100 mA @ 5 V	480 mA @ 5 V	120 mA @ 5 V	440 mA @ 5 V
Operating Temperature	0 °C ~ +50 °C			
Storage Temperature	-20 °C ~ +70 °C			
Humidity	0 ~ 90% RH, non-condensing			
Dimensions (L x W x D)	134 mm x 90 mm x 22 mm		110 mm x 94 mm x 22 mm	

Software

- Driver for 32-bit and 64-bit Windows XP/2003/Vista/7
- Driver for Linux

Pin Assignments

Pin Assignment	Terminal	No.	Pin Assignment
GND/VEE	05	09	CTS-(A)
RxD-(A)	04	08	CTS+(B)
RxD+(B)	03	07	RTS+(B)
TxD+(B)/Data+(B)	02	06	RTS-(A)
TxD-(A)/Data-(A)	01		

RS-422/485 Male DB-9 Connector

Ordering Information

VXC-142AU CR	Universal PCI , Serial Communication Card with 2 RS-422/485 ports (RoHS)
VXC-142iAU CR	Universal PCI , Serial Communication Card with 2 Isolated RS-422/485 ports (RoHS)
VEX-142 CR	PCI Express, Serial Communication Card with 2 RS-422/485 ports (RoHS)
VEX-142i CR	PCI Express, Serial Communication Card with 2 Isolated RS-422/485 ports (RoHS)

Accessories

CA-0910F	9-Pin Female-Female D-Sub Cable 1 m
CA-0915	9-Pin Male-Female D-Sub Cable, 1.5 m
CA-PC09F	9-Pin Female D-Sub Connector with Plastic Cover
DN-09-2F	I/O Connector Block with DIN-Rail Mounting and Two 9-Pin Male Header. Includes CA-0910F x 2 (9-Pin Female-Female D-Sub Cable 1 m)

VXC-144U/VXC-144iU **NEW**

VXC-144U/VXC-144iU

VEX-144/VEX-144i

VEX-144/VEX-144i **NEW**

Serial Communication Card with 4 RS-422/485 ports



Features ▶▶▶▶

- 128-byte Hardware FIFO for Each Port
- Supports 3.3 V/5 V PCI Bus for U versions
- +/-4 kV ESD Protection for i versions
- Supports pull-high/-low jumpers on RS-485 port
- Supports PCI Express x1 for VEX series
- Automatic RS-485 Direction Control
- Built-in COM-Selector
- Provides 2 RS-422/485 ports
- 2500 V_{rms} Isolation for i versions
- Short Card Design
- RoHS compliant & no Halogen

Hardware Specifications

Models	VXC-144U	VXC-144iU	VEX-144	VEX-144i
Communication Port				
COM1 ~ COM4	RS-422/485	The RS-422 and RS-485 cannot be used simultaneously		
	RS-422	TxD+, TxD-, RxD+, RxD-, RTS+, RTS-, CTS+, CTS-, GND		
	RS-485	Data+, Data-, GND (Automatic RS-485 Direction Control)		
UART	16C950 compatible			
Baud Rate	50 ~ 115200 bps			
Data Bit	5, 6, 7, 8			
Stop Bit	1, 1.5, 2			
Parity	None, Even, Odd, Mark, Space			
FIFO	Internal 128 bytes			
Isolated	-	2500 V _{rms}	-	2500 V _{rms}
General				
Bus Type	Universal PCI, 3.3 V and 5 V, 33 MHz, 32-bit, Plug and Play		PCI Express x1, Plug and Play	
COM-Selector	Yes (8-bit DIP switch)			
Connector	Female DB-37			
Power Consumption	120 mA @ 5 V	880 mA @ 5 V	120 mA @ 5 V	880 mA @ 5 V
Operating Temperature	0 °C ~ +50 °C			
Storage Temperature	-20 °C ~ +70 °C			
Humidity	0 ~ 90% RH, non-condensing			
Dimensions (L x W x D) (Unit: mm)	142 x 84 x 22	142 x 95 x 22	114 x 101 x 22	

Software

- Driver for 32-bit and 64-bit Windows XP/2003/Vista/7
- Driver for Linux

Ordering Information

VXC-144U CR	Universal PCI, Serial Communication Card with 4 RS-422/485 ports (RoHS). Includes One CA-4002 Connector
VXC-144iU CR	Universal PCI, Serial Communication Card with 4 Isolated RS-422/485 ports (RoHS). Includes One CA-4002 Connector
VEX-144 CR	PCI Express, Serial Communication Card with 4 RS-422/485 ports (RoHS). Includes One CA-4002 Connector
VEX-144i CR	PCI Express, Serial Communication Card with 4 Isolated RS-422/485 ports (RoHS). Includes One CA-4002 Connector

Accessories

CA-4002	37-Pin Male D-Sub Connector with Plastic Cover
CA-9-3715D	Male DB-37 to 4-port Male DB-9 Cable, 1.5 M (180°)
CA-9-3705	Male DB-37 to 4-port Male DB-9 Cable, 0.3 M (90°)

Pin Assignments

Pin Assignment	Terminal	No.	Pin Assignment
N.C.	01	20	CTS3- (A)
TxD3- (A)/Data3- (A)	02	21	RxD3- (A)
GND	03	22	RTS3- (A)
CTS3+ (B)	04	23	RTS3+ (B)
TxD3+ (B)/Data3+ (B)	05	24	RxD3+ (B)
CTS4- (A)	06	25	TxD4- (A)/Data4- (A)
RxD4- (A)	07	26	GND/VEE4
RTS4- (A)	08	27	CTS4+ (B)
RTS4+ (B)	09	28	TxD4+ (B)/Data4+ (B)
RxD4+ (B)	10	29	CTS2- (A)
TxD2- (A)/Data2- (A)	11	30	RxD2- (A)
GND/VEE2	12	31	RTS2- (A)
CTS2+ (B)	13	32	RTS2+ (B)
TxD2+ (B)/Data2+ (B)	14	33	RxD2+ (B)
CTS1- (A)	15	34	TxD1- (A)/Data1- (A)
RxD1- (A)	16	35	GND/VEE1
RTS1- (A)	17	36	CTS1+ (B)
RTS1+ (B)	18	37	TxD1+ (B)/Data1+ (B)
RxD1+ (B)	19		

RS-422/485 Female DB-37 Connector

Pin Assignment	Terminal	No.	Pin Assignment
GND/VEE	05	09	CTS- (A)
RxD- (A)	04	08	CTS+ (B)
RxD+ (B)	03	07	RTS+ (B)
TxD+ (B)/Data+ (B)	02	06	RTS- (A)
TxD- (A)/Data- (A)	01		

RS-422/485 Female DB-37 to Male DB-9 Connector

VXC-182iU *NEW*

Serial Communication Card with 1 Isolated RS-422/485 port and 1 RS-232 port



Features ▶▶▶▶

- Built-in COM-Selector
- Provides 1 RS-422/485 port and 1 RS-232 Port
- 2500 V_{rms} Isolated RS-422/485 Port
- Supports 3.3 V/5 V PCI bus, Plug and Play
- Up to 128 KB Software FIFO for Each Port Under Windows
- Short Card Design
- +/-4 kV ESD Protection
- 128-byte Hardware FIFO for Each Port
- Automatic RS-485 Direction Control
- RoHS compliant & no Halogen

Hardware Specifications

Communication Port		
COM1	RS-422/485	The RS-422 and RS-485 cannot be used simultaneously
	RS-422	TxD+, TxD-, RxD+, RxD-, RTS+, RTS-, CTS+, CTS-, GND (with 2.5 kV Isolation)
	RS-485	Data+, Data-, GND (with 2.5 kV Isolation)
COM2		RS-232 (TxD, RxD, RTS, CTS, DTR, DSR, DCD, RI, GND)
UART		16C950 compatible
Baud Rate		50 ~ 115200 bps
Data Bit		5, 6, 7, 8
Stop Bit		1, 1.5, 2
Parity		None, Even, Odd, Mark, Space
FIFO		Internal 128 bytes
General		
Bus Type		Universal PCI, 3.3 V and 5 V, 33 MHz, 32-bit, Plug and Play mechanism
COM-Selector		Yes (8-bit DIP switch)
Connector		2 x DB-9 (Male)
Power Consumption		200 mA @ 5 V
Operating Temperature		0 °C ~ +50 °C
Storage Temperature		-20 °C ~ +70 °C
Humidity		0 ~ 90% RH, non-condensing
Dimensions (L x W x D)		134 mm x 90 mm x 22 mm

Software

- Driver for 32-bit and 64-bit Windows XP/2003/ Vista/7
- Driver for Linux

Ordering Information

VXC-182iU CR	Universal PCI Bus, Serial Communication Card with 1 Isolated RS-422/485 port and 1 RS-232 port (RoHS)
--------------	---

Accessories

CA-0910F	9-Pin Female-Female D-Sub Cable 1 m
CA-0915	9-Pin Male-Female D-Sub Cable, 1.5 m
CA-090910	9-Pin Female D-Sub Cable for RS-422 Connector, 1 m
CA-PC09F	9-Pin Female D-Sub Connector with Plastic Cover
DN-09-2F	I/O Connector Block with DIN-Rail Mounting and Two 9-Pin Male Header. Includes CA-0910F x 2 (9-Pin Female-Female D-Sub Cable 1 m)

Pin Assignments

Pin Assignment	Terminal	No.	Pin Assignment
GND/VEE	05	09	CTS-(A)
RxD-(A)	04	08	CTS+(B)
RxD+(B)	03	07	RTS+(B)
TxD+(B)/Data+(B)	02	06	RTS-(A)
TxD-(A)/Data-(A)	01		

RS-422/485 Male DB-9 Connector

Pin Assignment	Terminal	No.	Pin Assignment
GND	05	09	RI
DTR	04	08	CTS
TxD	03	07	RTS
RxD	02	06	DSR
DCD	01		

COM2: RS-232 Male DB-9 Connector

VXC-164AU *Available soon*

Serial Communication Card with 4 RS-232/422/485 ports



Features ▶▶▶▶

- Supports 3.3 V/5 V PCI Bus
- 128-byte Hardware FIFO for Each Port
- Supports Pull-high/-low jumpers on RS-485 port
- Supports COM-Selector (DIP Switch)
- Automatic RS-485 Direction Control
- Provides 4 RS-232/422/485 ports
- Short Card Design
- RoHS compliant & no Halogen

Hardware Specifications

Communication Port		
COM1 ~ COM4	RS-232	RS-232 (TxD, RxD, RTS, CTS, DTR, DSR, DCD, RI, GND)
	RS-422/485	The RS-422 and RS-485 cannot be used simultaneously
	RS-422	TxD+, TxD-, RxD+, RxD-, RTS+, RTS-, CTS+, CTS-, GND
	RS-485	Data+, Data-, GND (Automatic RS-485 Direction Control)
UART		16C950 compatible
Baud Rate		50 ~ 115200 bps
Data Bit		5, 6, 7, 8
Stop Bit		1, 1.5, 2
Parity		None, Even, Odd, Mark, Space
FIFO		Internal 128 bytes
General		
Bus Type		Universal PCI, 3.3 V and 5 V, 33 MHz, 32-bit, Plug and Play
COM-Selector		Yes (8-bit DIP switch)
Connector		Female DB-37
Power Consumption		120 mA @ 5 V
Operating Temperature		0 °C ~ +50 °C
Storage Temperature		-20 °C ~ +70 °C
Humidity		0 ~ 90% RH, non-condensing
Dimensions (L x W x D)		142 mm x 84 mm x 22 mm

Software

- Driver for 32-bit and 64-bit Windows XP/2003/ Vista/7
- Driver for Linux

Ordering Information

VXC-164AU CR	Universal PCI, Serial Communication Card with 4 RS-232/422/485 ports (RoHS). Includes one CA-4002 Connector
VXC-164AU/D2 CR	Universal PCI, Serial Communication Card with 4 RS-232/422/485 ports (RoHS). Includes one CA-9-3715D Cable

Accessories

CA-4002	37-Pin Male D-Sub Connector with Plastic Cover
CA-9-3715D	Male DB-37 to 4-port Male DB-9 Cable, 1.5 M (180°)
CA-9-3705	Male DB-37 to 4-port Male DB-9 Cable, 0.3 M (90°)

Pin Assignments

Pin Assignment		Terminal No.	Pin Assignment	
RS-232	RS-422/485		RS-422/485	RS-232
N.C.		01		
DCD3	TxD3-(A)/Data3-(A)	02	20	CTS3-(A)
GND		03	21	RxD3-(A)
CTS3	CTS3+(B)	04	22	RTS3-(A)
RxD3	TxD3+(B)/Data3+(B)	05	23	RTS3+(B)
RI4	CTS4-(A)	06	24	RxD3+(B)
DTR4	RxD4-(A)	07	25	TxD4-(A)/Data4-(A)
DSR4	RTS4-(A)	08	26	GND/VEE4
TRS4	RTS4+(B)	09	27	CTS4+(B)
TxD4	RxD4+(B)	10	28	TxD4+(B)/Data+(B)
DCD2	TxD2-(A)/Data2-(A)	11	29	CTS2-(A)
GND	GND/VEE2	12	30	RxD2-(A)
CTS2	CTS2+(B)	13	31	RTS2-(A)
RxD2	TxD2+(B)/Data2+(B)	14	32	RTS2+(B)
RI1	CTS1-(A)	15	33	RxD2+(B)
DTR1	RxD1-(A)	16	34	TxD1-(A)/Data1-(A)
DSR1	RTS1-(A)	17	35	GND/VEE1
RTS1	RTS1+(B)	18	36	CTS1+(B)
TxD1	RxD1+(B)	19	37	TxD1+(B)/Data1+(B)

RS-232/422/485 Female DB-37 Connector

Pin Assignment		Terminal No.	Pin Assignment	
GND/VEE			05	09
RxD-(A)		04	08	CTS+(B)
RxD+(B)		03	07	RTS+(B)
TxD+(B)/Data+(B)		02	06	RTS-(A)
TxD-(A)/Data-(A)		01		

RS-422/485 Female DB-37 to Male DB-9 Connector

Pin Assignment		Terminal No.	Pin Assignment	
GND			05	09
DTR		04	08	CTS
TxD		03	07	RTS
RxD		02	06	DSR
DCD		01		

RS-232 Female DB-37 to Male DB-9 Connector

VXC-118U *Available soon*

VXC-118U

VEX-118

VEX-118 *Available soon*

Serial Communication Card with 8 RS-232 ports



Features ▶▶▶▶

- Supports 3.3 V/5 V PCI Bus for VXC-118U
- PCI Express x1, Plug & Play for VEX-118
- Provides 8 RS-232 ports
- 256-byte Hardware FIFO for Each Port
- Built-in COM-Selector
- 128 KB software Buffer (max.) for each COM port under Windows
- Supports COM-Selector (DIP Switch)
- Short Card Design
- RoHS compliant & no Halogen

Hardware Specifications

Models	VXC-118U	VEX-118
Communication Port		
COM1 ~ COM8	RS-232	RS-232 (TxD, RxD, RTS, CTS, DTR, DSR, DCD, GND)
UART	16C950 compatible	
Baud Rate	50 ~ 115200 bps	
Data Bit	5, 6, 7, 8	
Stop Bit	1, 1.5, 2	
Parity	None, Even, Odd, Mark, Space	
FIFO	Internal 256 bytes	
General		
Bus Type	3.3 V/ 5 V Universal PCI, 32-bit, 33 MHz	PCI Express x1
COM-Selector	Yes (8-bit DIP switch)	
Connector	Female DB-62	
Power Consumption	120 mA @ 5 V	
Operating Temperature	0 °C ~ +60 °C	
Storage Temperature	-20 °C ~ +70 °C	
Humidity	0 ~ 90% RH, non-condensing	
Dimensions (L x W x D)	132 mm x 121 mm x 22 mm	

Pin Assignments

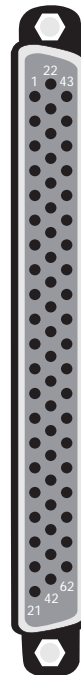

Terminal No.	Pin Assignment	Terminal No.	Pin Assignment	Terminal No.	Pin Assignment
01	TxD_0	22	RxD_0	43	CTS_0
02	DTR_0	23	DSR_0	44	RTS_0
03	RxD_1	24	DCD_0	45	GND
04	DSR_1	25	TxD_1	46	CTS_1
05	DCD_1	26	DTR_1	47	RTS_1
06	TxD_2	27	RxD_2	48	CTS_2
07	DTR_2	28	DSR_2	49	RTS_2
08	RxD_3	29	DCD_2	50	GND
09	DSR_3	30	TxD_3	51	CTS_3
10	DCD_3	31	DTR_3	52	RTS_3
11	RxD_4	32	GND	53	CTS_4
12	DSR_4	33	TxD_4	54	RTS_4
13	DCD_4	34	DTR_4	55	GND
14	TxD_5	35	RxD_5	56	CTS_5
15	DTR_5	36	DSR_5	57	RTS_5
16	RxD_6	37	DCD_5	58	GND
17	DSR_6	38	TxD_6	59	CTS_6
18	DCD_6	39	DTR_6	60	RTS_6
19	RxD_7	40	GND	61	CTS_7
20	DSR_7	41	TxD_7	62	RTS_7
21	DCD_7	42	DTR_7		

CON1

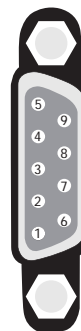

Terminal No.	Pin Assignment
01	DCD
02	RxD
03	TxD
04	DTR
05	GND
06	DSR
07	RTS
08	CTS
09	-

RS-232 Female DB-62 to Male DB-9 Connector

Software

- Driver for 32-bit Windows XP/2003/Vista/7
- Driver for 64-bit Windows XP/2003/Vista/7

Ordering Information

VXC-118U CR	Universal PCI, Serial Communication Card with 8 RS-232 ports. (RoHS)
VEX-118 CR	PCI Express, Serial Communication Card with 8 RS-232 ports. (RoHS)

VXC-148U-5w *Available soon*

VEX-148-5w *Available soon*

Serial Communication Card with 8 RS-422/485 ports



VXC-148U-5w

VEX-148-5w



Features ▶▶▶

- Supports 3.3 V/5 V PCI Bus for VXC-148U-5w
- PCI Express x1, Plug & Play for VEX-148-5w
- Provides 8 RS-422/485 ports
- 256-byte Hardware FIFO for Each Port
- Built-in COM-Selector
- 128 KB software Buffer (max.) for each COM port under Windows
- Supports COM-Selector (DIP Switch)
- Short Card Design
- RoHS compliant & no Halogen

Hardware Specifications

Models	VXC-148U-5w	VEX-148-5w
Communication Port		
COM1 ~ COM8	RS-422/485	The RS-422 and RS-485 cannot be used simultaneously
	RS-422	TxD+, TxD-, RxD+, RxD-, GND
	RS-485	Data+, Data-, GND
UART	16C950 compatible	
Baud Rate	50 ~ 115200 bps	
Data Bit	5, 6, 7, 8	
Stop Bit	1, 1.5, 2	
Parity	None, Even, Odd, Mark, Space	
FIFO	Internal 256 bytes	
General		
Bus Type	3.3 V/ 5 V Universal PCI, 32-bit, 33 MHz	PCI Express x1
COM-Selector	Yes (8-bit DIP switch)	
Connector	Female DB-62	
Power Consumption	120 mA @ 5 V	
Operating Temperature	0 °C ~ +60 °C	
Storage Temperature	-20 °C ~ +70 °C	
Humidity	0 ~ 90% RH, non-condensing	
Dimensions (L x W x D)	128 mm x 121 mm x 22 mm	

Pin Assignments

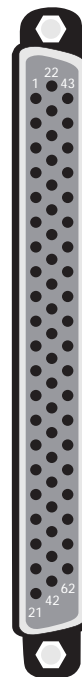

Terminal No.	Pin Assignment	Terminal No.	Pin Assignment	Terminal No.	Pin Assignment
01	RxD0+	22	TxD0+/Data0+	43	-
02	RxD0-	23	-	44	-
03	TxD1+/Data1+	24	TxD0-/Data0-	45	GND
04	-	25	RxD1+	46	-
05	TxD1-/Data1-	26	RxD1-	47	-
06	RxD2+	27	TxD2+/Data2+	48	-
07	RxD2-	28	-	49	-
08	TxD3+/Data3+	29	TxD2-/Data2-	50	GND
09	-	30	RxD3+	51	-
10	TxD3-/Data3-	31	RxD3-	52	-
11	TxD4+/Data4+	32	GND	53	-
12	-	33	RxD4+	54	-
13	TxD4-/Data4-	34	RxD4-	55	GND
14	RxD5+	35	TxD5+/Data5+	56	-
15	RxD5-	36	-	57	-
16	TxD6+/Data6+	37	TxD5-/Data5-	58	GND
17	-	38	RxD6+	59	-
18	TxD6-/Data6-	39	RxD6-	60	-
19	TxD7+/Data7+	40	GND	61	-
20	-	41	RxD7+	62	-
21	TxD7-/Data7-	42	RxD7-		

CON1

Software

- Driver for 32-bit Windows XP/2003/Vista/7
- Driver for 64-bit Windows XP/2003/Vista/7

Ordering Information

VXC-148U-5w CR	Universal PCI, Serial Communication Card with 8 RS-422/485 ports. (RoHS)
VEX-148-5w CR	PCI Express, Serial Communication Card with 8 RS-422/485 ports. (RoHS)

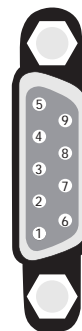

Terminal No.	Pin Assignment
01	TxD-/Data-
02	TxD+/Data+
03	RxD+
04	RxD-
05	GND
06	-
07	-
08	-
09	-

RS-422/485 Female DB-62 to Male DB-9 Connector

2-3 Applications

2

3

Multi-port Serial Cards

The Administration System of Parking Structure

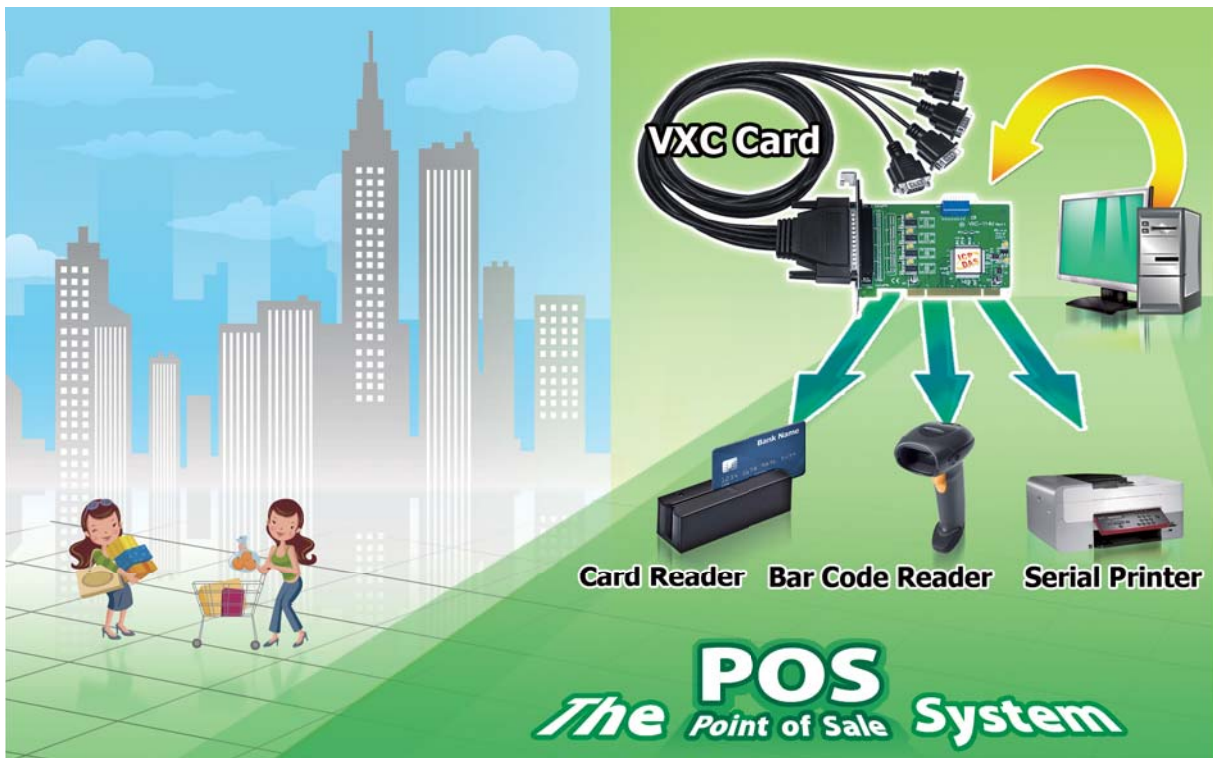
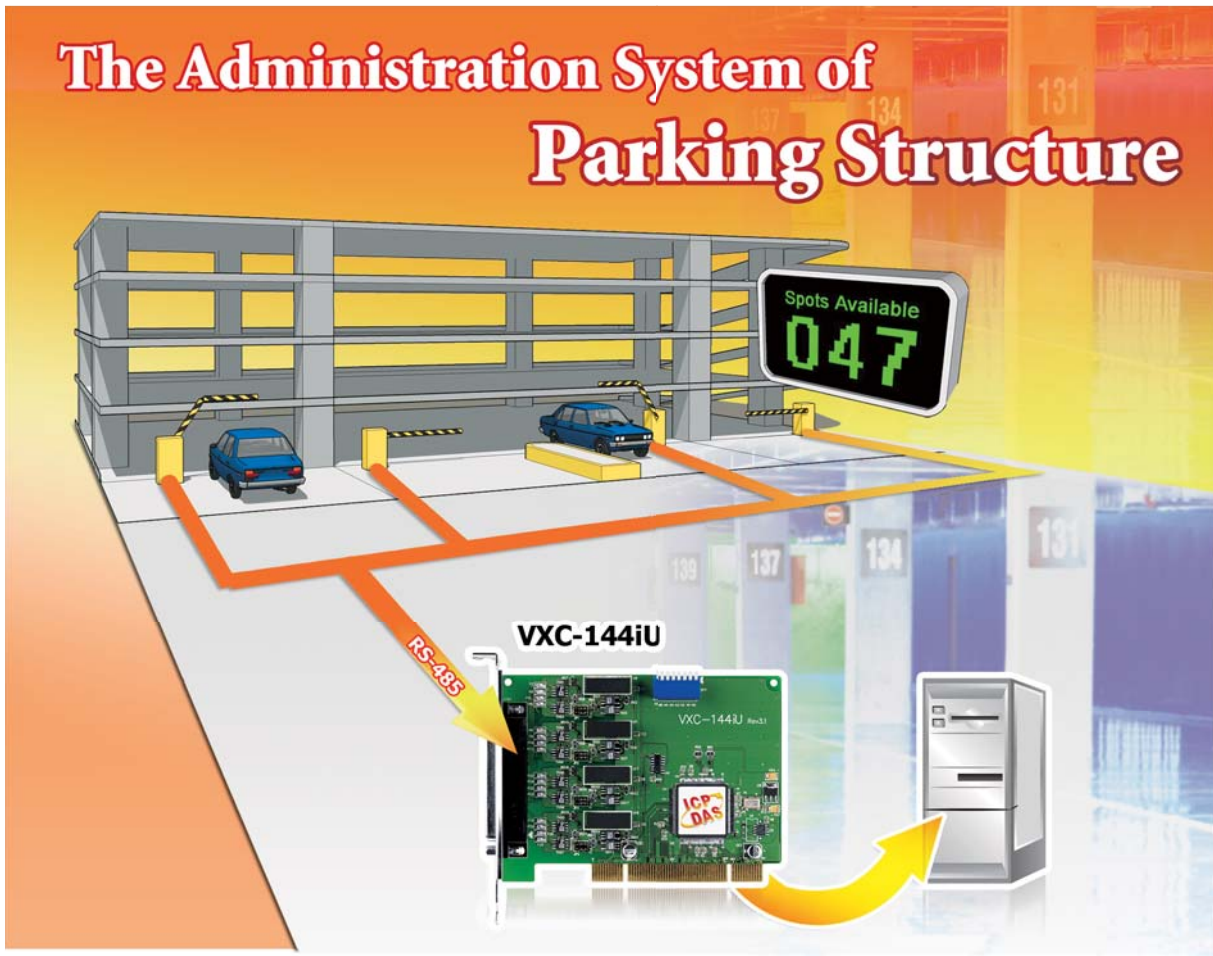

VXC/VEX Card

Battery Pool Test & Monitor

2
3

Multi-port Serial Cards

Entry Access Control

VXC/VEX Card

Weighing Machine & Labeler Control

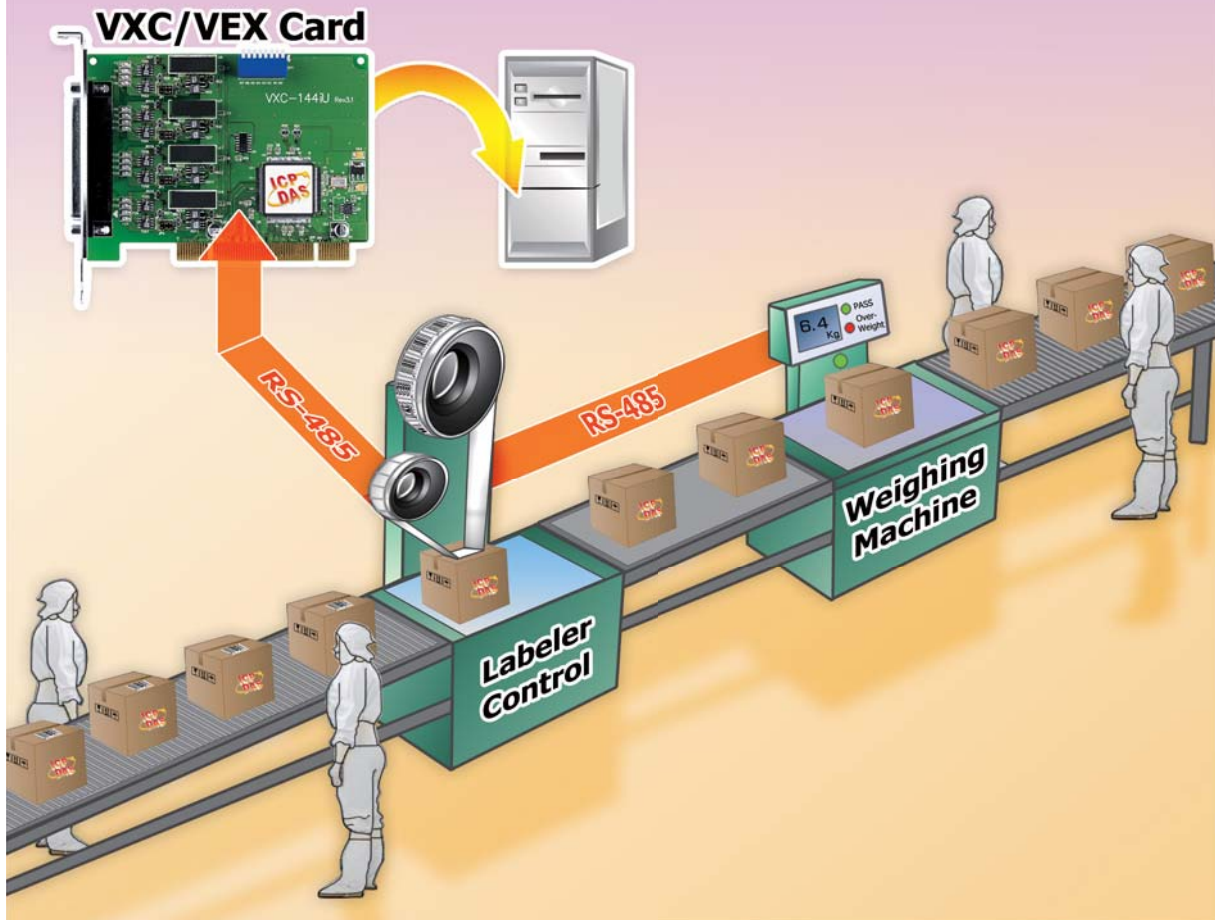

Pipeline Pressure Drop Monitor



Serial Device Server



3-1 Overview	3-1-1
3-2 Palm-size Programmable Serial-to-Ethernet Device Server	3-2-1
3-3 Palm-size Serial-to-Ethernet Device Server	3-3-1
3-4 IP67 Programmable Serial-to-Ethernet Device Server	3-4-1
3-5 Modular Programmable Serial-to-Ethernet Device Server	3-5-1
• Programmable Device Server with I/O Expansion Slot(s)	3-5-1
• Communication I/O Modules	3-5-6
3-6 Programmable Serial-to-Fiber Device Server	3-6-1
3-7 Tiny Serial-to-Ethernet Device Server & Modbus Gateway	3-7-1
3-8 Programmable Serial Device Server with LAN Switch	3-8-1
3-9 Programmable Modbus to Ethernet Gateway	3-9-1



3-1 Overview

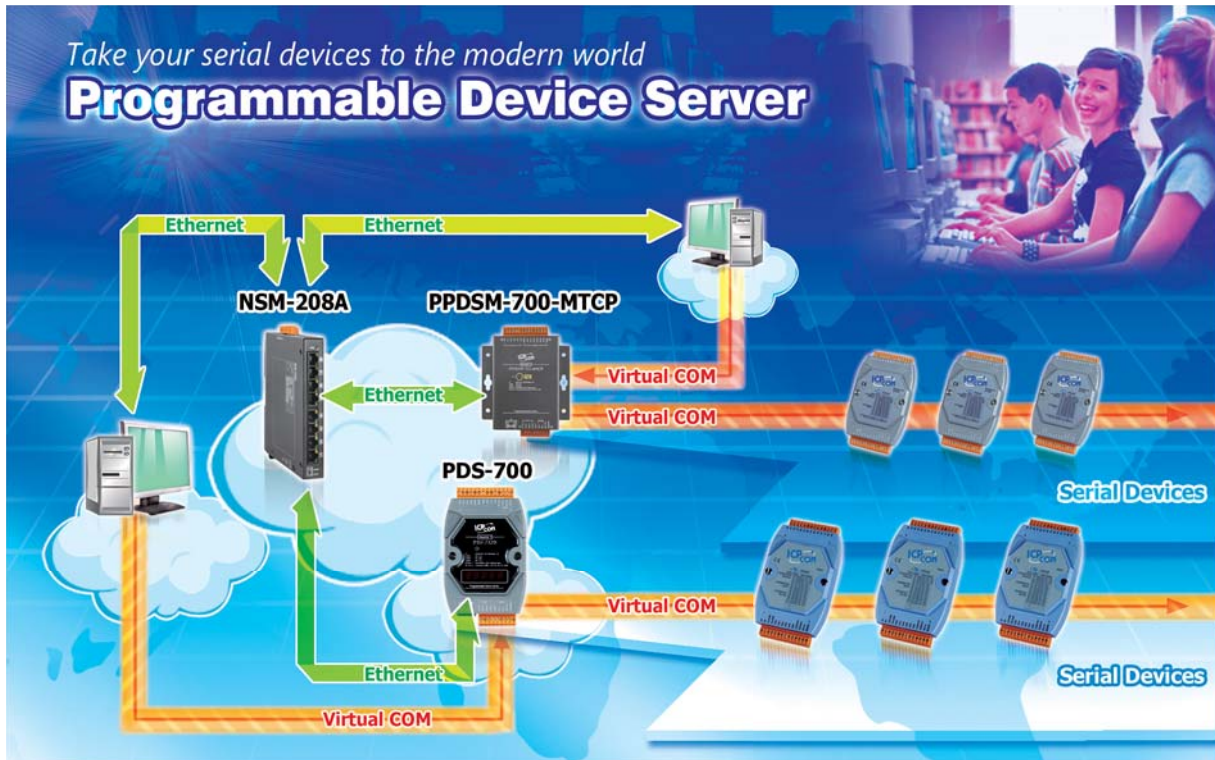

• Serial Devices to Ethernet Gateway

The ICP DAS Programmable Device Server is designed to bring network connectivity to your serial devices. The programmable features allow developers to quickly build custom applications that turn “dull” serial devices into “intelligent” devices right away without modifying their hardware or software configuration.

With extensive experience accumulated over many years, a great number of serial devices such as PLCs, bar code readers, RFID readers, meters and motion controllers, etc., have been widely used in various applications. As the advances in communication technologies in recent years, continue to drive optimization of data accessibility and remote operation ability, a wide variety of industries have begun to feel the urge to upgrade their latency serial communications to Ethernet network connections. The ICP DAS PDS series of products are your best choice for implementing this scenario in a robust, reliable and cost-effective way.

The VxComm Driver creates virtual COM port(s) on 32-bit and 64-bit Windows XP/2003/Vista/7 systems and maps them to the remote serial port(s) of the PDS/DS series. The user's serial client programs need to only be changed to the virtual COM port access the serial devices that are allocated on the Internet or Ethernet network via the PDS/DS series.



Easy Serial Device Networking with "transparency"

The most intuitive and easiest way to remotely control serial devices is to access those devices transparently via a network with no software modification required. The ICP DAS PDS product line offers two transparent applications:

■ **Socket Connections:**

Using a TCP/IP socket connection, client programs can exchange information with specific PDS/DS serial ports and talk to serial devices directly. For example, simply create a socket connection to the TCP/IP port 10001 (default) of the PDS/DS device and you can then access Port1 of the PDS/DS remotely. This is an OS-independent method and works well on most OS (operating systems) that provide socket functions.

■ **Virtual COM Ports:**

ICP DAS developed a specific function called "Virtual COM" that simulates PDS serial ports as fixed PC COM ports. Virtual COM ports appear to the system and applications as real ports. Once established, users can immediately enjoy the convenience that networking provides.



DynaCOM Technology

ICP DAS Virtual COM also supports an exclusive function - Dynamic Virtual COM Mapping (DynaCOM); if the system can only access limited or fixed numbers of COM Ports, specific PDS serial ports can be dynamically assigned to the corresponding COM port numbers.

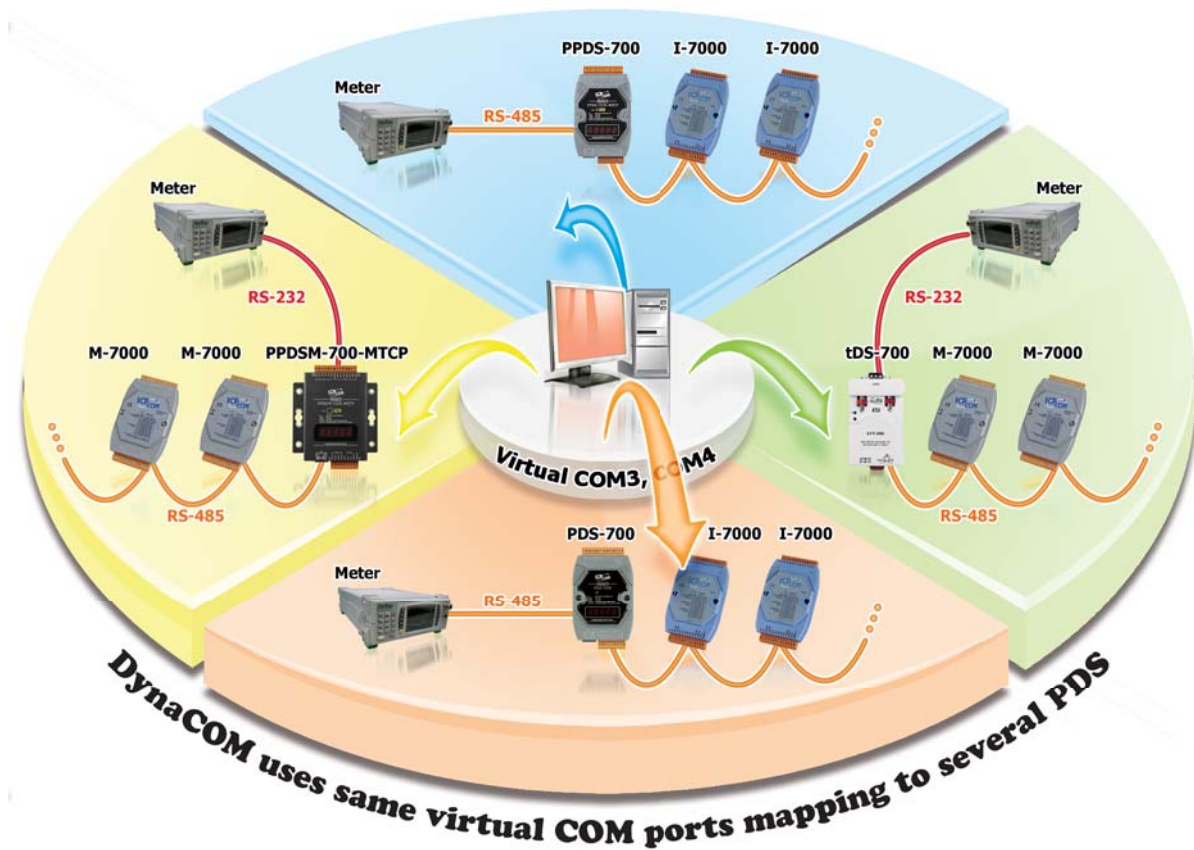

Programmable Enhanced "Device Servers"

The programmable features of the PDS series of products makes it possible to effectively implement exclusive protocols and exclusive communication mechanisms for complex PDS-based applications. This provides the following advantages:

- Effective network transmission:
Place your customized software on the PDS to directly perform processes locally. The effective data and information can be periodically sent back to the PC based on a schedule that can be planned in advance and the devices will work independently on-site, even when not connected to a network. Therefore, the design of system can be much more flexible. This also reduces the need to rely on the network, which is an inevitable factor for conventional DS (Device Server) as it has to keep on "talking" to the PC via the network to ensure the status maintains transparency.

- Previous development efforts can be duplicated:
Along with serial devices, you can place your customized or value-added software on the PDS to implement an intelligent Ethernet controller. This controller can then be used in applications for future projects, dramatically reducing programming requirements. In addition, your value-added software is embedded in the PDS, so if a computer system undergoes hardware replacement or upgrade, incompatibility issues don't need to be considered, which therefore reduces system maintenance work.

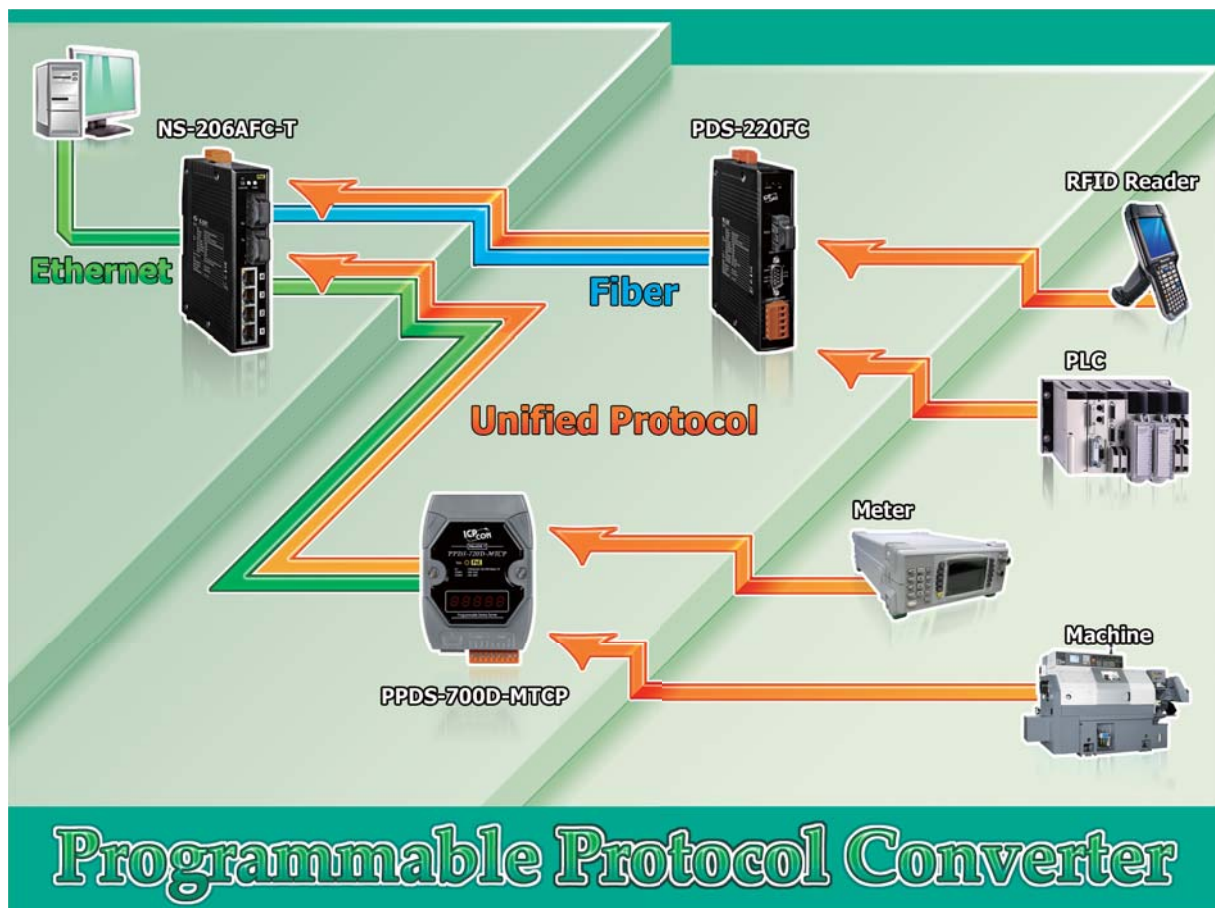

Virtual I/O Highly Integrates On-Site Messages

I/O acquisition is very important when performing on-site integration. The RS-485 port of PDS is able to be connected to I/O devices, like I-7000/M-7000 series, to offer abundant I/O functions for various purposes. For easier on-site integration, some PDS models also provide Digital I/O, which is also supported by the ICP DAS DCON utility, EZ Data Logger or other DCON client programs.

EZ Data Logger
 DCON Modbus TCP Modbus Serial
 Virtual Channel Definition Control Logic (VB Script)
 Alarm Notifier High/Low Alarm AIP Camera Viewer Data Trend
 Layout Database and Report

"Virtual I/O" is an extension of "Virtual COM" technology that simulates the PDS's digital I/Os control as a virtual COM port (Port I/O) application on the PC. You are now able to access the PDS's digital I/Os using the DCON protocol through the virtual COM port.

In addition, the DCON utility and EZ Data Logger also support control of the PDS's digital I/Os through the use of "Virtual I/O" technology, so you can monitor PDS's digital I/Os and complete the I/Os application in a convenient way.

3
1
Serial Device Server



ESD Protection and Frame Ground

The PDS series offers TVS diode ESD protection technology with a frame ground design that protects your system from being damaged by high potential voltages.

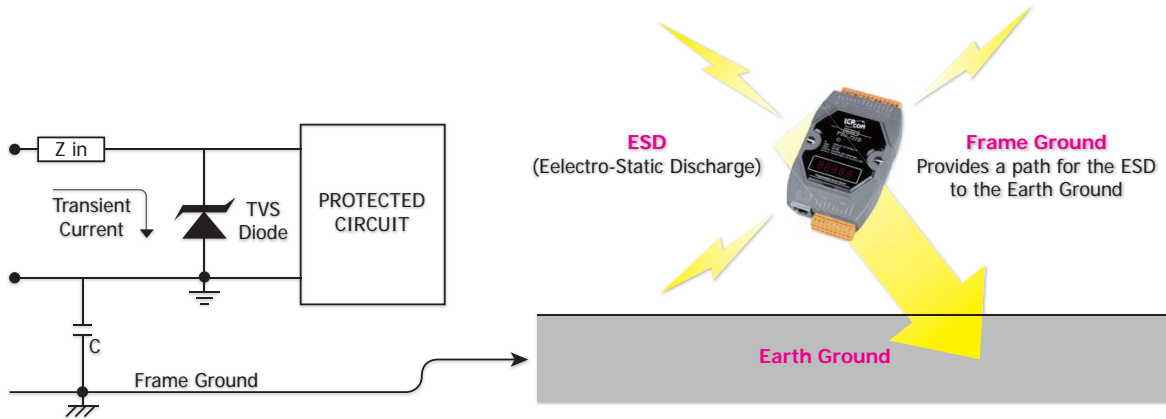

Under normal operating conditions, the TVS diode presents high impedance (appears as an open circuit) to the protected component. If the voltage exceeds the limitation, the TVS diode avalanches, providing a low impedance path for the transient current. As a result, the transient current is diverted away from the protected components and shunted through the TVS diode. The device returns to a high impedance state after the transient threat has passed.

Self-Tuner Inside

The PDS series is equipped with a "Self-Tuner" chip that automatically controls the sending/receiving direction of the RS-485 ports.

Without the presence of Self-Tuner, users need to enable the RS-485 transmitter before transmitting, and disable the transmitter after the transmission is complete. The time required to enable and disable the transmitter (direction control) is the major source of many communication issues, and it is very difficult to debug. The built-in Self-Tuner in the PDS effectively removes this direction control issue and also simplifies the software/firmware programming required for communication applications.

Easy Web Configuration

The PDS also contains a built-in web server that enables users to conveniently configure the PDS. A web browser, like IE or Firefox, can be used to connect to the PDS to modify the configuration, such as: IP address, subnet mask, gateway, DHCP client, UDP search, Web Server, Telnet Server, TCP ACK delay, Watchdog timeout, Master IP, Filter IP, COM port baud rate, data format and transfer mode, etc.

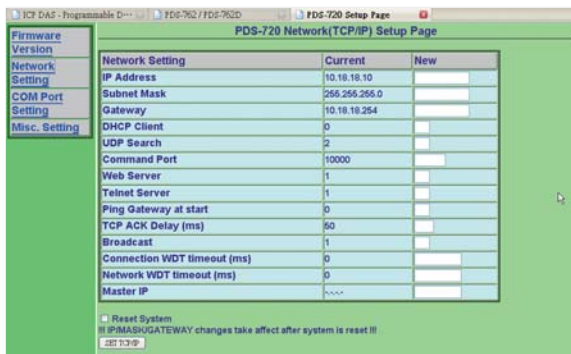

Master IP and Filter IP (White List)

The PDS can use a master IP setting that allows a client to configure the PDS and COM ports. This prevents the configuration of the PDS and COM ports from being changed by other clients.

The IP filter setting limits which client PCs are able to access the PDS module via specific IP addresses. Connections from other clients will be rejected by the PDS.

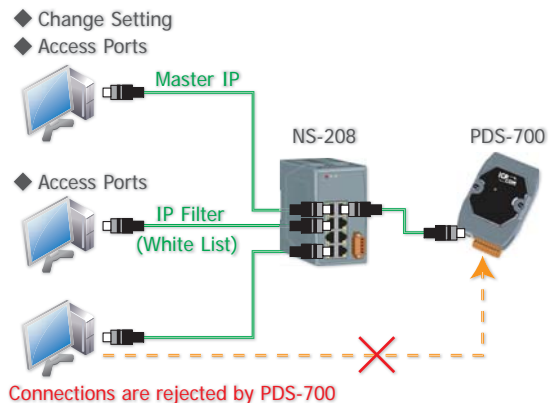



• Selection Guide







Comparison Table of Device Server and Modbus Gateway

Features	PPDS	PDS	DS	tDS	tGW
Virtual COM	Yes	Yes	Yes	Yes	–
Programmable	Yes	Yes	–	–	–
PoE	Yes	–	–	Yes	Yes
Modbus Gateway	Yes	–	–	–	Yes
Multi-client	Yes	Yes	Yes	–	–
Remarks	Professional	Powerful	Isolation for DS-715	Cost-effective, Entry-level	Cost-effective, Entry-level



✓ PPDS Series – Programmable Device Server and Modbus Gateway with PoE

Series	Ethernet	Virtual COM	Virtual I/O	Programmable	Modbus	Casing
 PPDS-700-MTCP	10/100 M, PoE	Yes	Yes	Yes	Yes	Fire-Retardant Plastic
 PPDSM-700-MTCP						Metal
 PPDS-700-IP67			–			IP67 Waterproof Plastic

✓ PDS Series – Programmable Device Server

Series	Ethernet	Virtual COM	Virtual I/O	Programmable	Modbus	Casing
 PDS-700	10/100 M	Yes	Yes	Yes	–	Fire-Retardant Plastic
 PDSM-700						Metal
 PDS-8x1	10/100 M Ethernet Switch		–			–
 PDS-8x2	Dual 10/100 M Ethernet					
 PDS-220Fx	100 Base-FX, Fiber					
 PDS-5000-MTCP	10/100 M Ethernet Switch	–	–	–	Yes	Fire-Retardant Plastic

✓ DS, tDS & tGW Series – Non-Programmable Device Server and Modbus Gateway

Series	Ethernet	Virtual COM	Virtual I/O	Multi-client	Modbus	Casing	Remarks
 DS-700	10/100 M	Yes	–	Yes	–	Fire-Retardant Plastic	Isolation for DS-715
 tDS-700	10/100 M, PoE			–			–
 tGW-700		–	–	Yes	Cost-effective		

3

1

Serial Device Server

3-2 Palm-size Programmable Serial-to-Ethernet Device Server

PDS-720(D)

PPDS-720(D)-MTCP

Programmable Device Server with 1 RS-232 port and 1 RS-485 port



PPDS-720D-MTCP PDS-720



PDS-782-25/D6

PDS-782D-25/D6

Programmable Device Server with 7 RS-232 ports and 1 RS-485 port



PDS(M)-700(D) Series

PPDS(M)-700(D)-MTCP Series

Programmable Device Server with 1 RS-232 port and 1 RS-485 port

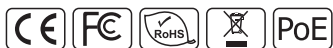

PPDS-700D-MTCP series PDSM-700D series



Features ▶▶▶▶

- Incorporates serial devices in an Ethernet network
- Provides Virtual COM for 32-bit and 64-bit Windows XP/2003/Vista/7
- Supports Modbus TCP to RTU/ASCII Gateway (for MTCP versions)
- Powerful programmable device server with lib and sample programs
- Built-in high performance MiniOS7 from ICP DAS
- Built-in watchdog timer suitable for use in harsh environments
- Built-in Self-Tuner on RS-485 Ports (automatic direction control)
- Supports +/- 4 kV ESD protection on serial ports
- Power reverse polarity protection and low power consumption
- 10/100 Base-TX Ethernet, RJ-45 Port (Auto-negotiating, auto MDI/MDI-X, LED indicator)
- Supports PoE (Power over Ethernet, for PPDS versions)
- Built-in 7-Segment 5-digit LED display (for D versions)
- Supports D/I, latched D/I and counter functions (for models with DIO)
- Supports Virtual I/O technology (for models with DIO)
- Supports IP filter (White List) for security control
- Supports multi-client and data sharing function
- Palm-size form factor with multiple serial ports and DIN-Rail mounting
- Made from fire-retardant materials (UL94-V0 Level)
- RoHS Compliant & no Halogen
- OEM/ODM service is available

Introduction

The PDS-700/PPDS-700-MTCP series is a family of Programmable Device Servers, also known as "Serial-to-Ethernet gateway", that are designed for linking RS-232/422/485 devices to an Ethernet network. The user-friendly VxComm Driver/Utility allows users to easily turn the built-in COM ports of the PDS-700/PPDS-700-MTCP series into standard COM ports on a PC. By virtue of its protocol independence, a small-core OS and high flexibility, the PDS-700/PPDS-700-MTCP series is able to meet the demands of every network-enabled application.

The PDS-700/PPDS-700-MTCP series includes a powerful and reliable Xserver programming structure that allows you to quickly and easily build your robust Ethernet applications. The built-in, high-performance MiniOS7 boots the PDS-700/PPDS-700-MTCP up in just one second and gives you fastest responses.

These modules also provide advanced features like data sharing and UDP flood attack protection as follows:

Data Sharing with Multiple Clients

M0: Transparent Mode (Multi-echo)

In transparent mode, the PDS sends data from a serial device to each client that is connected to the same serial port of the PDS. Thus, each connected client has a copy of the same data from the serial device.

M1: Slave Mode (Single-echo)

In slave mode, the PDS only sends data from a serial device to the client that requires the service. If there are no requirements from the client, then data will not be sent to the client. The PDS services each client individually when sharing data from the serial device, but the clients do not have a copy of the same data.

UDP Flood Attack Protection

A UDP flood attack is a denial-of-service (DoS) attack that sends a large number of UDP packets to a remote host. As a result, the affected system will be forced into replying to many packets, eventually causing the host to be unreachable by other clients.

The UDP function can be disabled on the PDS if the network suffers a flood attack or receives a large numbers of UDP packets from the network devices. This protects the PDS from UDP flood attacks.

The PPDS-700-MTCP series features true IEEE 802.3af compliant (classification, Class 1) Power over Ethernet (PoE) using a standard category 5 Ethernet cable to receive power from a PoE switch like the NS-205PSE. The PPDS-700-MTCP also works as a Modbus/TCP to RTU/ASCII gateway that supports most SCADA/HMI communications based on the Modbus/TCP protocol.

The removable onboard terminal block connector is designed for easy and robust wiring in industrial situations.

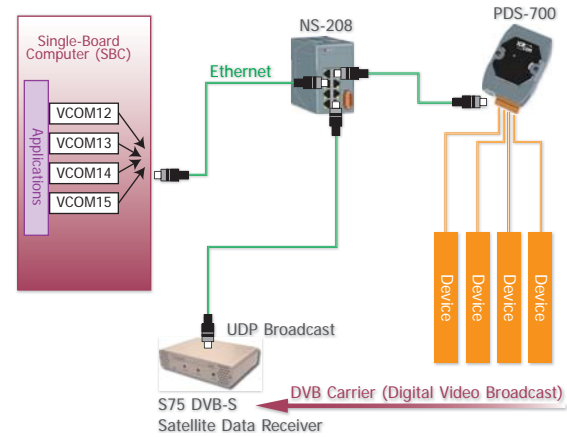
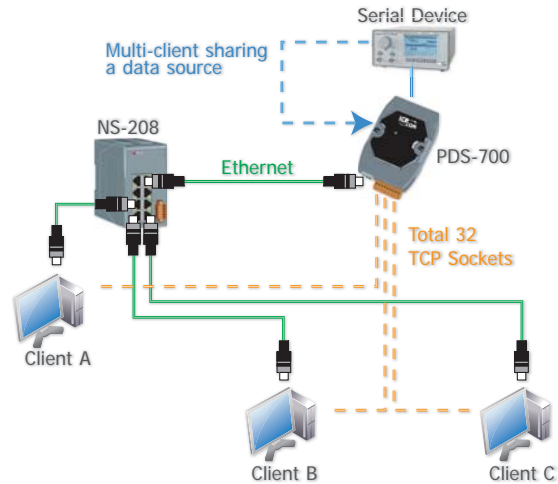

Applications

○ Factory Automation

○ Building Automation

○ Home Automation

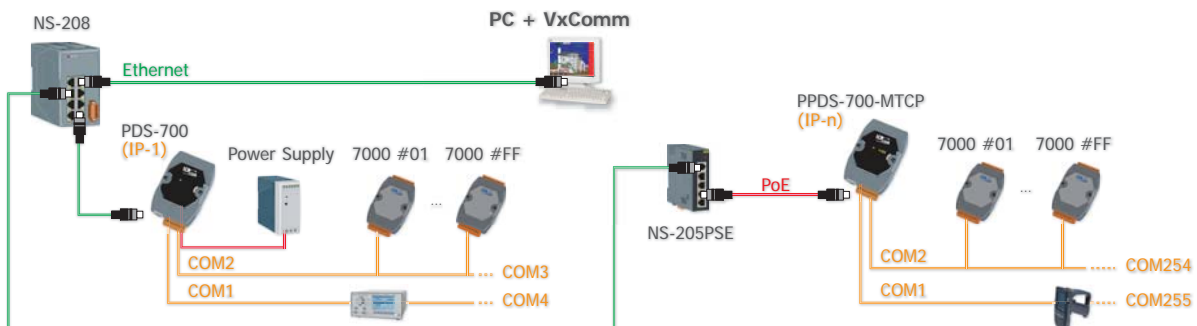

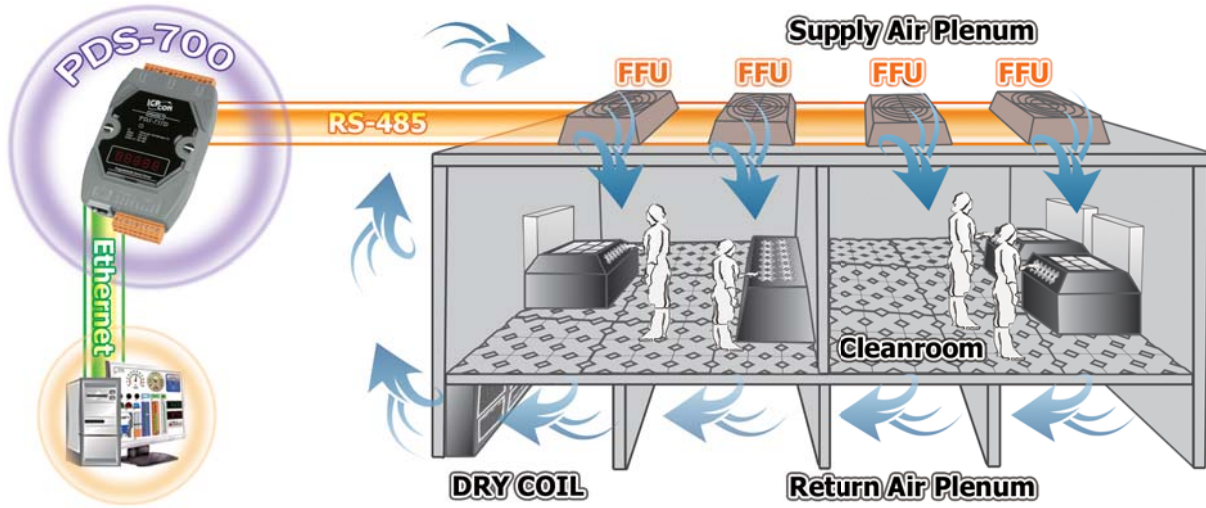

3

2

Serial Device Server

Selection Guide

Model Name	RS-232	RS-485	RS-422/ RS-485	DI/DO	Ethernet	COM1	COM2	COM3	COM4	COM5	COM6	COM7	COM8
PDS-720(D) PPDS-720(D)-MTCP	1	1	-	-	10/100 M	5-wire RS-232	2-wire RS-485	-	-	-	-	-	-
PDS(M)-721(D) PPDS(M)-721(D)-MTCP	1	1	-	6/7	10/100 M	5-wire RS-232	2-wire RS-485	-	-	-	-	-	-
PDS(M)-732(D) PPDS(M)-732(D)-MTCP	2	1	-	4/4	10/100 M	5-wire RS-232	2-wire RS-485	5-wire RS-232	-	-	-	-	-
PDS(M)-734(D) PPDS(M)-734(D)-MTCP	1	1	1	4/4	10/100 M	5-wire RS-232	2-wire RS-485	RS-422/ RS-485	-	-	-	-	-
PDS(M)-742(D) PPDS(M)-742(D)-MTCP	3	1	-	-	10/100 M	5-wire RS-232	2-wire RS-485	5-wire RS-232	9-wire RS-232	-	-	-	-
PDS(M)-743(D) PPDS(M)-743(D)-MTCP	3	1	-	4/4	10/100 M	5-wire RS-232	2-wire RS-485	3-wire RS-232	3-wire RS-232	-	-	-	-
PDS(M)-752(D) PPDS(M)-752(D)-MTCP	4	1	-	-	10/100 M	5-wire RS-232	2-wire RS-485	5-wire RS-232	5-wire RS-232	5-wire RS-232	-	-	-
PDS(M)-755(D) PPDS(M)-755(D)-MTCP	1	4	-	-	10/100 M	5-wire RS-232	2-wire RS-485	2-wire RS-485	2-wire RS-485	2-wire RS-485	-	-	-
PDS(M)-762(D) PPDS(M)-762(D)-MTCP	5	1	-	1/2	10/100 M	5-wire RS-232	2-wire RS-485	3-wire RS-232	3-wire RS-232	3-wire RS-232	3-wire RS-232	-	-
PDS(M)-782(D) PPDS(M)-782(D)-MTCP	7	1	-	-	10/100 M	5-wire RS-232	2-wire RS-485	3-wire RS-232	3-wire RS-232	3-wire RS-232	3-wire RS-232	3-wire RS-232	3-wire RS-232
PDS-782(D)-25/D6	7	1	-	-	10/100 M	5-wire RS-232	2-wire RS-485	3-wire RS-232	3-wire RS-232	3-wire RS-232	3-wire RS-232	3-wire RS-232	3-wire RS-232

Note:

1. The D version modules have a built-in 7-Seg. LED Display.
2. The M version modules use metal case.
3. The PPDS-700-MTCP series modules support PoE (Power over Ethernet) and Modbus Gateway.

System Specifications

CPU		
CPU	80186, 80 MHz or compatible	
SRAM	512 KB	
Flash Memory	Flash ROM: 512 KB; Erase unit is one sector (64 KB); 100,000 erase/write cycles	
EEPROM	16 KB; Data retention: 40 years; 1,000,000 erase/write cycles	
Built-in Watchdog Timer	Yes	
Communication Interface		
Ethernet	10/100 Base-TX, RJ-45 port (Auto-negotiating, auto MDI/MDI-X, LED indicator)	
PoE	IEEE 802.3af (PPDS(M)-700(D)-MTCP series only)	
COM Port Formats		
Data Bit	COM1 and COM2	7, 8
	COM3 ~ COM8	5, 6, 7, 8
Parity	None, Even, Odd, Mark, Space	
Stop Bit	COM1 ~ COM8	1, 2
Baud Rate	115200 bps max.	
LED Indicators		
5-digit 7 Segment	Yes (D versions only)	
System	Red	
PoE	Green (PPDS(M)-700(D)-MTCP series only)	
Power		
Protection	Power Reverse Polarity Protection	
Required Supply Voltage	PDS(M)-700(D) Series	+10 V _{DC} ~ +30 V _{DC} (non-regulated)
	PPDS(M)-700(D)-MTCP Series	PoE or +12 V _{DC} ~ +48 V _{DC} (non-regulated)
Power Consumption	D versions (LED display)	2.9 W
	Others	2.2 W
Mechanical		
Flammability	M versions (Metal case)	Metal
	Others	Plastic Fire-Retardant Materials (UL94-V0 Level)
Dimensions (W x H x D)	M versions (Metal case)	88 mm x 123 mm x 28 mm
	Others	72 mm x 123 mm x 35 mm
Installation	DIN-Rail or Wall mounting	
Environment		
Operating Temperature	-25 °C ~ +75 °C	
Storage Temperature	-40 °C ~ +80 °C	
Humidity	5 ~ 90% RH, non-condensing	

I/O Specifications

Digital Output		
Output Type	Open Collector (Sink/NPN)	
Load Voltage	30 V _{DC} , max.	
Load Current	100 mA, max.	
Isolated Voltage	Non-isolated	
Digital Input		
Input Type	Source (Dry Type), Common Ground	
Off Voltage Level	+1 V max.	
On Voltage Level	+3.5 ~ +30 V	
Isolated Voltage	Non-isolated	
Counters	Max. Count	16-bit (65535)
	Max. Input Frequency	100 Hz
	Min. Pulse Width	5 ms

Pin Assignments

PDS(M)-700(D) & PPDS(M)-700(D)-MTCP Series

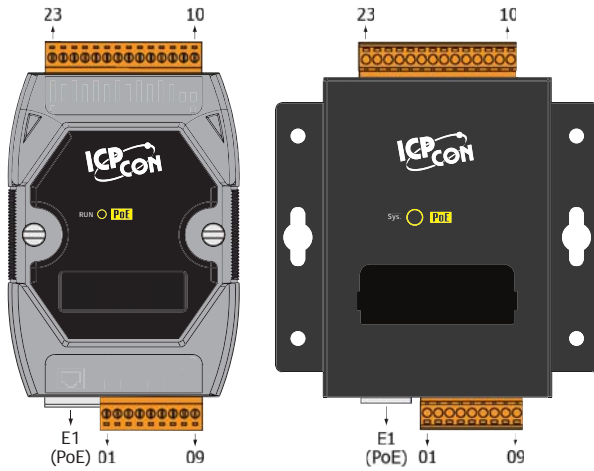

Terminal No.	Pin Assignment
E1	Link/Act
	10/100M
COM1	01 CTS1
	02 RTS1
	03 RxD1
	04 TxD1
COM2	05 INIT*
	06 D2+
COM2	07 D2-
	08 (R)+Vs
	09 (B)GND

PDS(M)-721(D) & PPDS(M)-721(D)-MTCP

Terminal No.	Pin Assignment
DI	23 DI0
	22 DI1
	21 DI2
	20 DI3
	19 DI4
DO	18 DI5
	17 DO.PWR
	16 DO0
	15 DO1
	14 DO2
	13 DO3
DO	12 DO4
	11 DO5
	10 DO6

PDS(M)-732(D) & PPDS(M)-732(D)-MTCP

Terminal No.	Pin Assignment
DO	23 DO3
	22 DO2
	21 DO1
	20 DO0
	19 DO.PWR
DI	18 GND
	17 DI3
	16 DI2
	15 DI1
COM3	14 DI0
	13 RxD3
	12 TxD3
	11 RTS3
	10 CTS3

PDS(M)-734(D) & PPDS(M)-734(D)-MTCP

Terminal No.	Pin Assignment
DO	23 DO3
	22 DO2
	21 DO1
	20 DO0
	19 DO.PWR
DI	18 GND
	17 DI3
	16 DI2
	15 DI1
COM3	14 DI0
	13 RxD3-
	12 RxD3+
	11 TxD3-/D3-
	10 TxD3+/D3+

PDS(M)-742(D) & PPDS(M)-742(D)-MTCP

Terminal No.	Pin Assignment
COM4	23 DI4
	22 DCD4
	21 DTR4
	20 DSR4
COM4	19 CTS4
	18 RTS4
	17 TxD4
	16 RxD4
COM3	15 GND4
	14 GND3
	13 RxD3
	12 TxD3
COM3	11 RTS3
	10 CTS3

PDS(M)-743(D) & PPDS(M)-743(D)-MTCP

Terminal No.	Pin Assignment
DO	23 DO3
	22 DO2
	21 DO1
	20 DO0
DI	19 DO.PWR
	18 GND
	17 DI3
COM3	16 DI2
	15 DI1
	14 DI0
COM4	13 TxD3
	12 RxD3
COM4	11 TxD4
	10 RxD4

PDS(M)-752(D) & PPDS(M)-752(D)-MTCP

Terminal No.	Pin Assignment
COM5	23 RxD5
	22 TxD5
	21 RTS5
	20 CTS5
COM4	19 GND
	18 RxD4
	17 TxD4
	16 RTS4
COM3	15 CTS4
	14 GND
	13 RxD3
	12 TxD3
COM3	11 RTS3
	10 CTS3

PDS(M)-755(D) & PPDS(M)-755(D)-MTCP

Terminal No.	Pin Assignment
COM5	23 DATA+
	22 DATA-
	21 --
COM4	20 --
	19 --
	18 --
COM4	17 DATA+
	16 DATA-
	15 --
COM3	14 --
	13 --
	12 --
COM3	11 DATA+
	10 DATA-

PDS(M)-762(D) & PPDS(M)-762(D)-MTCP

Terminal No.	Pin Assignment
DO	23 DO0
	22 DO1
	21 DO.PWR
DI	20 DI0
	19 GND
COM6	18 TxD6
	17 RxD6
	16 TxD5
COM5	15 RxD5
	14 GND
COM4	13 TxD4
	12 RxD4
COM3	11 TxD3
	10 RxD3

PDS(M)-782(D) & PPDS(M)-782(D)-MTCP

Terminal No.	Pin Assignment
COM8	23 TxD8
	22 RxD8
COM7	21 TxD7
	20 RxD7
COM6	19 GND
	18 TxD6
	17 RxD6
COM5	16 TxD5
	15 RxD5
COM4	14 GND
	13 TxD4
COM3	12 RxD4
	11 TxD3
COM3	10 RxD3

PDS-782(D)-25/D6

Pin Assignment	Terminal	No.	Pin Assignment
N/A	01	14	COM8_RxD
N/A	02	15	COM8_TxD
GND	03	16	COM7_RxD
N/A	04	17	COM7_TxD
GND	05	18	COM6_RxD
N/A	06	19	COM6_TxD
GND	07	20	COM5_RxD
N/A	08	21	COM5_TxD
GND	09	22	COM4_RxD
N/A	10	23	COM4_TxD
GND	11	24	COM3_RxD
N/A	12	25	COM3_TxD
GND	13		
		Shield	F.G.

25-Pin Male D-Sub Connector

Pin Assignment	Terminal	No.	Pin Assignment
GND	05	09	
--	04	08	--
TxD	03	07	--
RxD	02	06	--
--	01		

RS-232 Female DB-25 to Male DB-9 Connector

Wiring

2-wire RS-485 Wiring

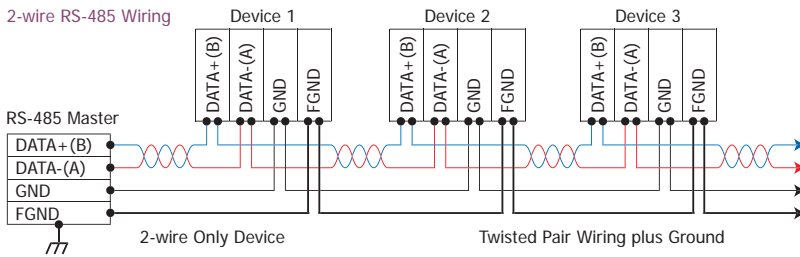

3-wire RS-232 Wiring

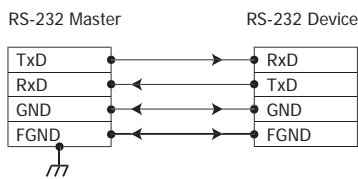

4-wire RS-422 Wiring

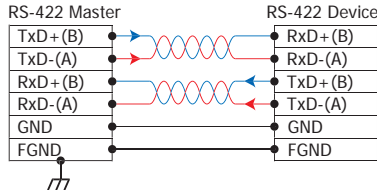

Output Type	DO Command as 1	DO Command as 0
Drive Relay	Relay ON 	Relay Off
	Resistance Load 	Resistance Load

Input Type	DI Value as 0	DI Value as 1
Relay Contact	Relay ON 	Relay Off
	Voltage < 1V	
TTL/CMOS Logic	Logic Level Low 	Logic Level High
	Voltage > 3.5V	
Open Collector	Open Collector On 	Open Collector Off

Ordering Information

Models							RS-232 RS-485 RS-422/485	DI/DO	Includes Cable	
PDS	M	- 7	D		CR					
P	PDS	M	- 7	D	- MTCP	CR				
PoE	Programmable Device Server	Metal		LED Display	Modbus/TCP	RoHS				
			P D S - 7 2 0	D		CR	1 RS-232 1 RS-485	-	1 CA-0910	
			P P D S - 7 2 0	D	-MTCP	CR				
			PDS	M	-721	D	CR	1 RS-232 1 RS-485	6/7	1 CA-0910
			PPDS	M	-721	D	-MTCP	CR		
			PDS	M	-732	D	CR	2 RS-232 1 RS-485	4/4	1 CA-0910
			PPDS	M	-732	D	-MTCP	CR		
			PDS	M	-734	D	CR	1 RS-232 1 RS-485	4/4	1 CA-0910
			PPDS	M	-734	D	-MTCP	CR	1 RS-422/485	
			PDS	M	-742	D	CR	3 RS-232 1 RS-485	-	1 CA-0910
			PPDS	M	-742	D	-MTCP	CR		
			PDS	M	-743	D	CR	3 RS-232 1 RS-485	4/4	1 CA-0910
			PPDS	M	-743	D	-MTCP	CR		
			PDS	M	-752	D	CR	4 RS-232 1 RS-485	-	1 CA-0910
			PPDS	M	-752	D	-MTCP	CR		
			PDS	M	-755	D	CR	1 RS-232 4 RS-485	-	1 CA-0910
			PPDS	M	-755	D	-MTCP	CR		
			PDS	M	-762	D	CR	5 RS-232 1 RS-485	1/2	1 CA-0910
			PPDS	M	-762	D	-MTCP	CR		
			PDS	M	-782	D	CR	7 RS-232 1 RS-485	-	1 CA-0910
			PPDS	M	-782	D	-MTCP	CR		
			P D S - 7 8 2	D	-25/D6	CR	7 RS-232 1 RS-485	-	1 CA-0910 1 CA-9-2505D	

Note:

1. PPDS(M)-700(D)-MTCP supports PoE and Modbus Gateway.
2. D versions support 7-segment 5-digit LED display.
3. M versions is equipped with metal case.

Accessories

GPSU06U-6	24 Vdc/0.25 A, 6 W Power Supply
MDR-20-24	24 Vdc/1 A, 24 W Power Supply with DIN-Rail Mounting
DIN-KA52F-48	48 Vdc/0.52 A, 25 W Power Supply with DIN-Rail Mounting
CA-0903	9-Pin Female D-Sub and RS-232 Connector Cable, 30 cm Cable
CA-0910	9-Pin Female D-Sub and 3-wire RS-232 Cable, 1 m Cable
CA-9-2505D	DB-25 Male (D-Sub) to 6-port DB-9 Male (D-Sub) Cable
NS-205 CR	Unmanaged 5-port Industrial Ethernet Switch (RoHS)
NS-205PSE CR	Unmanaged Ethernet Switch with 4 PoE Ports and 1 RJ-45 Uplink (RoHS)
DN-09-2	I/O Connector Block with DIN-Rail Mounting and Two 9-Pin Male Headers. Includes CA-0915 x 2 (9-Pin Male-Female D-Sub Cable 1.5 m)
DN-09-2F	I/O Connector Block with DIN-Rail Mounting and Two 9-Pin Male Headers. Includes CA-0910F x 2 (9-Pin Female-Female D-Sub Cable 1.0 m)

3-3 Palm-size Serial-to-Ethernet Device Server

DS-712 *NEW*

PPDS-712-MTCP *Available soon*

PPDS-712-MTCP DS-712

Serial-to-Ethernet Device Server with 1 RS-232 port



Features >>>

- Incorporate Serial Devices in an Ethernet network
- Virtual COM for 32-bit and 64-bit Windows XP/2003/Vista/7
- Watchdog Timer suitable for use in harsh environments
- 10/100 Base-TX, RJ-45 Port (Auto-negotiating, auto MDI/MDI-X, LED indicator)
- Built-in High Performance MiniOS7 from ICP DAS
- PPDS-712-MTCP supports Modbus/TCP and Modbus/RTU
- PPDS-712-MTCP supports PoE (IEEE 802.3af, Class 1)
- Made from fire-retardant materials (UL94-V0 Level)
- "Virtual COM" extends PC COM ports
- High Performance Device Server
- Power Reverse Polarity Protection
- RoHS Compliant & no Halogen
- Serial Port +/- 4 kV ESD Protection Circuit
- Low power consumption
- Palm-Size with DIN-Rail Mounting
- Male DB-9 Connector

Introduction

The DS-700 is a series of Serial-to-Ethernet Device Servers that are designed for linking RS-232/422/485 devices to an Ethernet network. By using the VxComm Driver/Utility, the built-in COM port of the DS-700 series can be virtualized to a standard PC COM port in Windows. By virtue of its protocol independence, a small size and flexibility, the DS-700 series meets the demands of virtually any network-enabled application.

The DS-712 is equipped with a male DB-9 connector and supports a 5-wire RS-232 port, while the DS-715 is equipped with a removable terminal block connector and supports a 4-wire RS-422 port or a 2-wire RS-485 port with 2000 V_{rms} isolation.

The DS-700 is a non-programmable device server, while the PPDS-700-MTCP is a programmable product. The PPDS-700-MTCP series features true IEEE 802.3af-compliant (classification, Class 1) Power over Ethernet (PoE) using a standard category 5 Ethernet cable to receive power from a PoE switch like the NS-205PSE. The PPDS-700-MTCP also works as a Modbus/TCP to Modbus/RTU gateway that supports most SCADA/HMI communications based on the Modbus/TCP protocol.

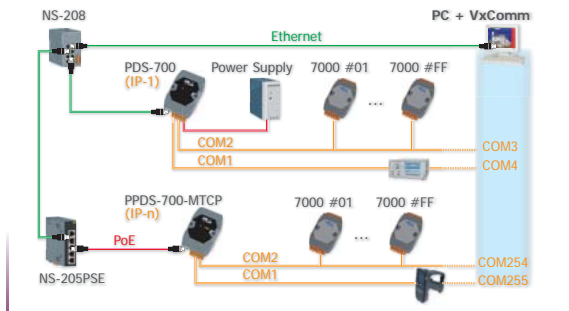

Applications

- Factory, Building and Home Automation

System Specifications

Models	DS-712	PPDS-712-MTCP
CPU		
CPU	80186, 80 MHz or compatible	
SRAM	512 KB	
Flash Memory	Flash ROM: 512 KB	
EEPROM	16 KB; Data retention: 40 years	
Built-in Watchdog Timer	Yes	
Communication Interface		
Non-isolated	COM1	RS-232 (TxD, RxD, RTS, CTS, GND)
Ethernet	10/100 Base-TX, RJ-45 port (Auto-negotiating, auto MDI/MDI-X, LED indicator)	
PoE	-	IEEE 802.3af
COM Port Formats		
Data Bit	7, 8	
Parity	None, Even, Odd, Mark, Space	
Stop Bit	1, 2	
Baud Rate	115200 bps max.	
LED Indicators		
L1	Run (Red)	
L2	Link/Act (Red)	
L3	10/100M (Orange)	
PoE	-	Green
Power		
Protection	Power Reverse Polarity Protection	
Required Supply Voltage	+12 Vdc ~ +48 Vdc (non-regulated)	PoE or +12 Vdc ~ +48 Vdc (non-regulated)
Power Consumption	2.0 W	2.2 W
Mechanical		
Flammability	Fire-Retardant Materials (UL94-V0 Level)	
Dimensions (W x H x D)	72 mm x 118 mm x 35 mm	
Installation	DIN-Rail or Wall mounting	
Environment		
Operating Temperature	-25 °C ~ +75 °C	
Storage Temperature	-40 °C ~ +80 °C	
Humidity	5 ~ 90% RH, non-condensing	

Pin Assignments

Terminal No.	Pin Assignment
E1	
01	N/A
02	N/A
03	N/A
04	N/A
05	INIT*
06	N/A
07	N/A
08	(R) +Vs
09	(B)GND



Pin Assignment	Terminal No.	Pin Assignment
GND	05	09
--	04	08
TxD	03	07
RxD	02	06
--	01	

COM1: Male DB-9 Connector

Wiring

3-wire RS-232 Wiring

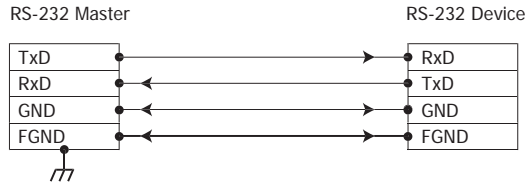

Dimensions (Unit: mm)

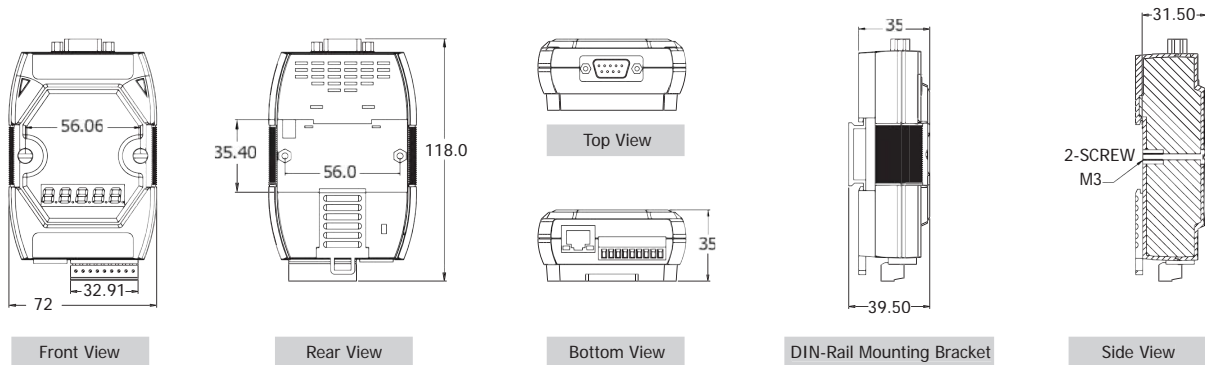

Ordering Information

DS-712 CR	Device Server with 1 RS-232 port (RoHS)
PPDS-712-MTCP CR	Programmable Device Server with PoE, Modbus/TCP and 1 RS-232 port (RoHS)

Accessories

GPSU06U-6	24 Vdc/0.25 A, 6 W Power Supply
MDR-20-24	24 Vdc/1 A, 24 W Power Supply with DIN-Rail Mounting
DIN-KAS2F-48	48 Vdc/0.52 A, 25 W Power Supply with DIN-Rail Mounting
CA-0915	9-Pin Male-Female D-Sub Cable, 1.5 m Cable
NS-205 CR	Unmanaged 5-port Industrial Ethernet Switch (RoHS)
NS-205PSE CR	Unmanaged Ethernet Switch with 4 PoE Ports and 1 RJ-45 Uplink (RoHS)
DN-09-2F	I/O Connector Block with DIN-Rail Mounting and Two 9-Pin Male Headers. Includes CA-0910F x 2 (9-Pin Female-Female D-Sub Cable 1.0 m)

DS-715 *NEW*

PPDS-715-MTCP *Available soon*

Serial-to-Ethernet Device Server with 1 RS-422/RS-485 port



PPDS-715-MTCP DS-715



Features ▶▶▶

- Incorporate Serial Devices in an Ethernet network
- Virtual COM for 32-bit and 64-bit Windows XP/2003/Vista/7
- Watchdog Timer suitable for use in harsh environments
- 10/100 Base-TX, RJ-45 Port (Auto-negotiating, auto MDI/MDI-X, LED indicator)
- Built-in High Performance MiniOS7 from ICP DAS
- PPDS-715-MTCP supports Modbus/TCP and Modbus/RTU
- PPDS-715-MTCP supports PoE (IEEE 802.3af, Class 1)
- Made from fire-retardant materials (UL94-V0 Level)
- "Virtual COM" extends PC COM ports
- High Performance Device Server
- Power Reverse Polarity Protection
- RoHS Compliant & no Halogen
- Serial Port +/-4 kV ESD Protection Circuit
- Self-Tuner ASIC Controller on the RS-485 Port
- Low power consumption
- Palm-Size with DIN-Rail Mounting

Introduction

The DS-700 is a series of Serial-to-Ethernet Device Servers that are designed for linking RS-232/422/485 devices to an Ethernet network. By using the VxComm Driver/Utility, the built-in COM port of the DS-700 series can be virtualized to a standard PC COM port in Windows. By virtue of its protocol independence, a small size and flexibility, the DS-700 series meets the demands of virtually any network-enabled application.

The DS-712 is equipped with a male DB-9 connector and supports a 5-wire RS-232 port, while the DS-715 is equipped with a removable terminal block connector and supports a 4-wire RS-422 port or a 2-wire RS-485 port with 2000 V_{rms} isolation.

The DS-700 is a non-programmable device server, while the PPDS-700-MTCP is a programmable product. The PPDS-700-MTCP series features true IEEE 802.3af-compliant (classification, Class 1) Power over Ethernet (PoE) using a standard category 5 Ethernet cable to receive power from a PoE switch like the NS-205PSE. The PPDS-700-MTCP also works as a Modbus/TCP to Modbus/RTU gateway that supports most SCADA/HMI communications based on the Modbus/TCP protocol.

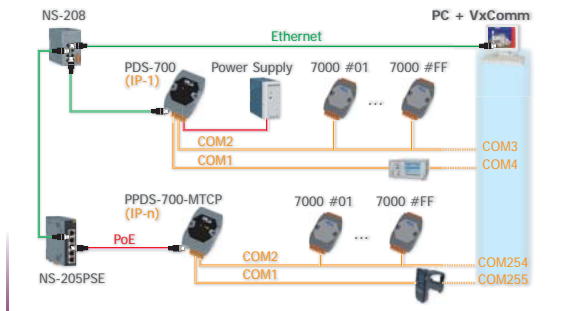

Applications

- Factory, Building and Home Automation

System Specifications

Models	DS-715	PPDS-715-MTCP
CPU		
CPU	80186, 80 MHz or compatible	
SRAM	512 KB	
Flash Memory	Flash ROM: 512 KB	
EEPROM	16 KB; Data retention: 40 years	
Built-in Watchdog Timer	Yes	
Communication Interface		
Isolated (2000 V _{rms})	COM1	RS-422 (TxD+, TxD-, RxD+, RxD-) RS-485 (D2+, D2-)
Ethernet	10/100 Base-TX, RJ-45 port (Auto-negotiating, auto MDI/MDI-X, LED indicator)	
PoE	-	IEEE 802.3af
COM Port Formats		
Data Bit	7, 8	
Parity	None, Even, Odd, Mark, Space	
Stop Bit	1, 2	
Baud Rate	115200 bps max.	
LED Indicators		
L1	Run (Red)	
L2	Link/Act (Red)	
L3	10/100M (Orange)	
PoE	-	Green
Power		
Protection	Power Reverse Polarity Protection	
Required Supply Voltage	+12 V _{dc} ~ +48 V _{dc} (non-regulated)	PoE or +12 V _{dc} ~ +48 V _{dc} (non-regulated)
Power Consumption	2.0 W	2.2 W
Mechanical		
Flammability	Fire-Retardant Materials (UL94-V0 Level)	
Dimensions (W x H x D)	72 mm x 124 mm x 35 mm	
Installation	DIN-Rail or Wall mounting	
Environment		
Operating Temperature	-25 °C ~ +75 °C	
Storage Temperature	-40 °C ~ +80 °C	
Humidity	5 ~ 90% RH, non-condensing	

Pin Assignments

Terminal No.	Pin Assignment
E1	
01	N/A
02	N/A
03	N/A
04	N/A
05	INIT*
06	N/A
07	N/A
08	(R)+Vs
09	(B)GND

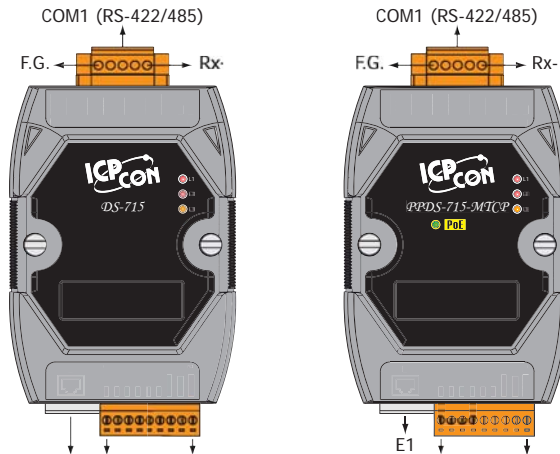

COM1 (RS-422/485)
F.G.
Tx+/D+
Tx-/D-
Rx+
Rx-

Wiring

2-wire RS-485 Wiring

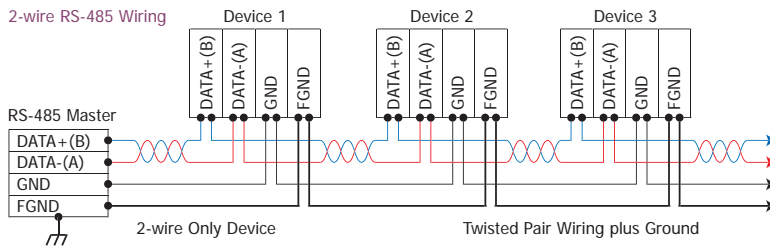

4-wire RS-422 Wiring

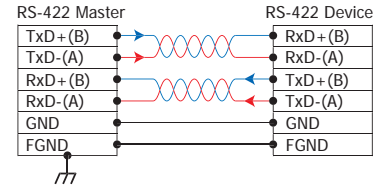

Dimensions (Unit: mm)

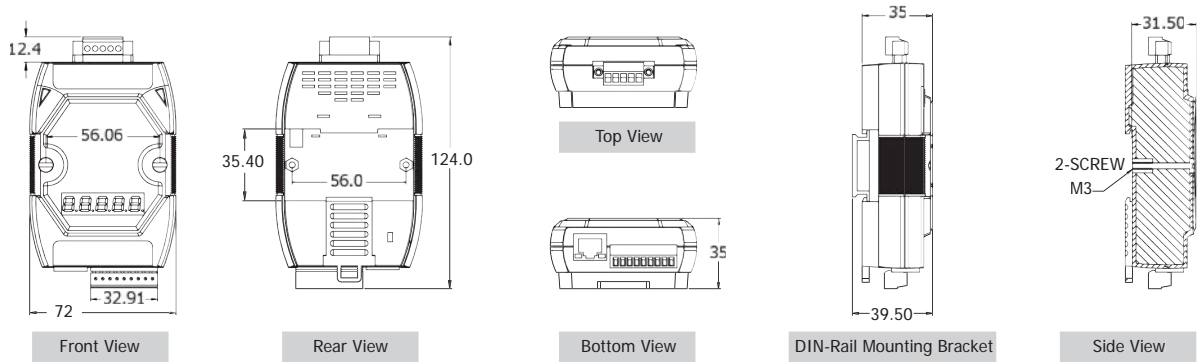

Ordering Information

DS-715 CR	Device Server with 1 Isolated RS-422/RS-485 port (RoHS)
PPDS-715-MTCP CR	Programmable Device Server with PoE, Modbus/TCP and 1 Isolated RS-422/485 port (RoHS)

Accessories

GPSU06U-6	24 Vdc/0.25 A, 6 W Power Supply
MDR-20-24	24 Vdc/1 A, 24 W Power Supply with DIN-Rail Mounting
DIN-KA52F-48	48 Vdc/0.52 A, 25 W Power Supply with DIN-Rail Mounting
NS-205 CR	Unmanaged 5-port Industrial Ethernet Switch (RoHS)
NS-205PSE CR	Unmanaged Ethernet Switch with 4 PoE Ports and 1 RJ-45 Uplink (RoHS)

3-4 IP67 Programmable Serial-to-Ethernet Device Server

PPDS-741-IP67(/DIN) *Available soon*

PPDS-742-IP67(/DIN) *Available soon*

PPDS-743-IP67(/DIN) *Available soon*

Programmable Device Server with 4 RS-232 or RS-485 ports, PoE and IP67 Casing



Features ▶▶▶▶

- Incorporate Serial Devices in an Ethernet network
- Virtual COM for 32-bit and 64-bit Windows XP/2003/Vista/7
- Watchdog Timer suitable for use in harsh environments
- 10/100 Base-TX, RJ-45 Port (Auto-negotiating, auto MDI/MDI-X, LED indicator)
- Built-in High Performance MiniOS7 from ICP DAS
- Self-Tuner ASIC Controller on the RS-485 Port
- Powerful Programmable Device Server
- Rugged RJ-45 Connector for anti-vibration and shock
- Plastic Casing with IP67 Waterproof
- Power Reverse Polarity Protection
- RoHS Compliant & no Halogen
- Serial Port +/-4 kV ESD Protection Circuit
- Low power consumption
- Supports PoE (IEEE 802.3af, Class 1)
- ODM Service is available

Introduction

The PPDS-700-IP67 series is a family of Programmable Device Servers, also known as "Serial-to-Ethernet gateway", that are designed for linking RS-232/422/485 devices to an Ethernet network. The user-friendly VxComm Driver/Utility allows users to easily turn the built-in COM ports of the PPDS-700-IP67 series into standard COM ports on a PC. By virtue of its protocol independence, a small-core OS and high flexibility, the PPDS-700-IP67 series is able to meet the demands of every network-enabled application.

The PPDS-700-IP67 series includes a powerful and reliable Xserver programming structure that allows you to design your robust Ethernet applications in one day. The built-in, high-performance MiniOS7 boots the PPDS-700-IP67 up in just one second and gives you fastest responses.

The PPDS-700-IP67 is a special design for the toughest applications. It can be directly mounted to any machine or convenient flat surface. The rugged packaging and IP67 connectors are rated to protect against water, oil, dust, vibration, and much more.

The PPDS-700-IP67 supports PoE (Power over Ethernet) function that allows power and data to be carried over a single Ethernet cable, so a device can operate solely from the power it receives through the data cable. This innovation allows greater flexibility in office design, higher efficiency in systems design, and faster turnaround time in set-up and implementation. When there is no PoE switch on site, the PPDS-700-IP67 accepts power input from a +12 V_{DC} ~ +48 V_{DC} adapter.

When using PoE devices such as the PPDS-700-MTCP, PPDS-700-IP67 and PET-7000 (Ethernet I/O module with PoE), you can select the ICP DAS "PoE" switch – "NS-205PSE" – as the power source. The NS-205PSE automatically detects whether the connected devices are PoE devices or not. This mechanism ensures that the NS-205PSE will work with both PoE and non-PoE devices simultaneously.

As a power source for PoE devices, the NS-205PSE requires a power input ranging from +46 V_{DC} ~ +55 V_{DC}.

Applications

Factory Automation

Transportation Automation

Chemical Industry Automation

Marine Automation



System Specifications

Models	PPDS-741-IP67(/DIN)	PPDS-742-IP67(/DIN)	PPDS-743-IP67(/DIN)
CPU			
CPU	80186, 80MHz or compatible		
SRAM	512 KB		
Flash Memory	Flash ROM: 512 KB; Erase unit is one sector (64 KB); 100,000 erase/write cycles		
EEPROM	16 KB; Data retention: 40 years; 1,000,000 erase/write cycles		
Watchdog Timer	Yes		
Communication Interface			
COM1	5-wire RS-232		
COM2	Isolated 2-wire RS-485		
COM3	Isolated 2-wire RS-485	5-wire RS-232	5-wire RS-232
COM4	Isolated 2-wire RS-485	Isolated 2-wire RS-485	5-wire RS-232
Ethernet	10/100 Base-TX, RJ-45 port (Auto-negotiating, Auto MDI/MDI-X, LED indicators), PoE (IEEE 802.3af, Class 1)		
COM Port Formats			
Data Bit	5, 6, 7, 8		
Parity	None, Even, Odd, Mark, Space		
Stop Bit	1, 2		
Baud Rate	115200 bps max.		
LED Indicators			
System	Red: Sys		
Ethernet	Green: Link/Act (E1), Orange: 10/100M (E1)		
COM1 ~ COM4	Green: RxD, Orange: TxD		
Power			
Protection	Power input reverse polarity protection		
Required Supply Voltage	+12 V _{DC} ~ +48 V _{DC} (non-regulated) or PoE (IEEE 802.3af, Class 1)		
Power Consumption	2.2 W		
Mechanical			
Flammability	Fire-Retardant Materials (UL94-V0 Level)		
Casing	Plastic casing with IP67 waterproof protection		
Dimensions (W x H x D)	85 mm x 76 mm x 137 mm (89 mm x 90 mm x 138 mm for /DIN versions)		
Installation	Wall mounting (DIN-Rail mounting for /DIN versions)		
Environment			
Operating Temperature	-10 °C ~ +60 °C		
Storage Temperature	-10 °C ~ +60 °C		
Humidity	100% RH for operating temperature -10 °C ~ +60 °C		
Note: 5-wire RS-232: TxD, RxD, CTS, RTS, GND Isolated 2-wire RS-485: DATA+, DATA-, GND; Self-Tuner Inside; 2500 V _{rms} Isolation			

Dimensions (Unit: mm)

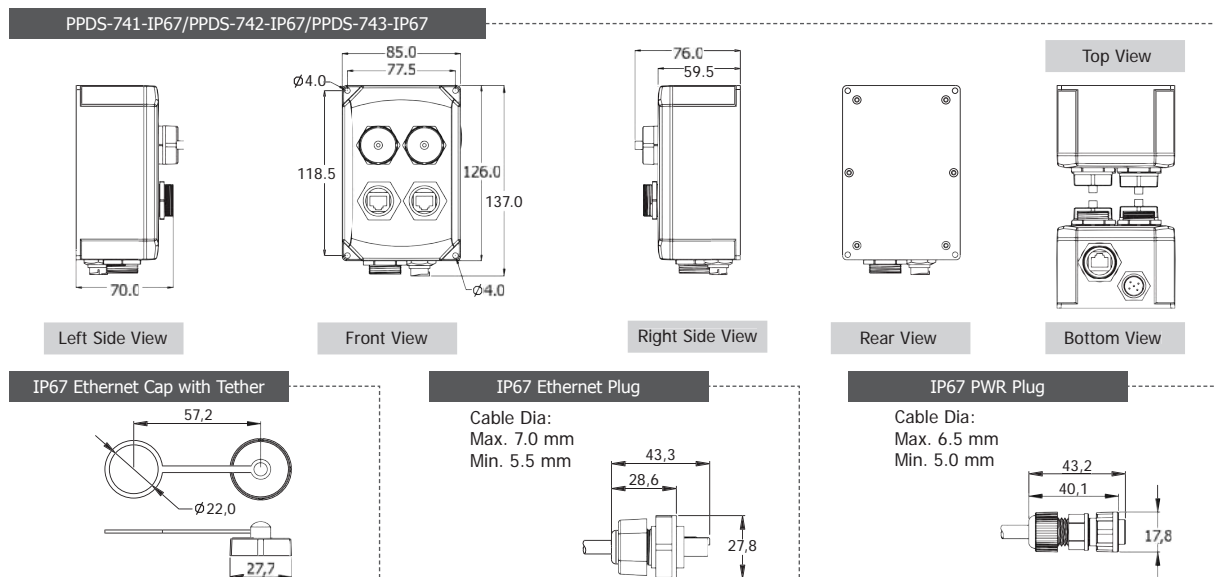

Pin Assignments

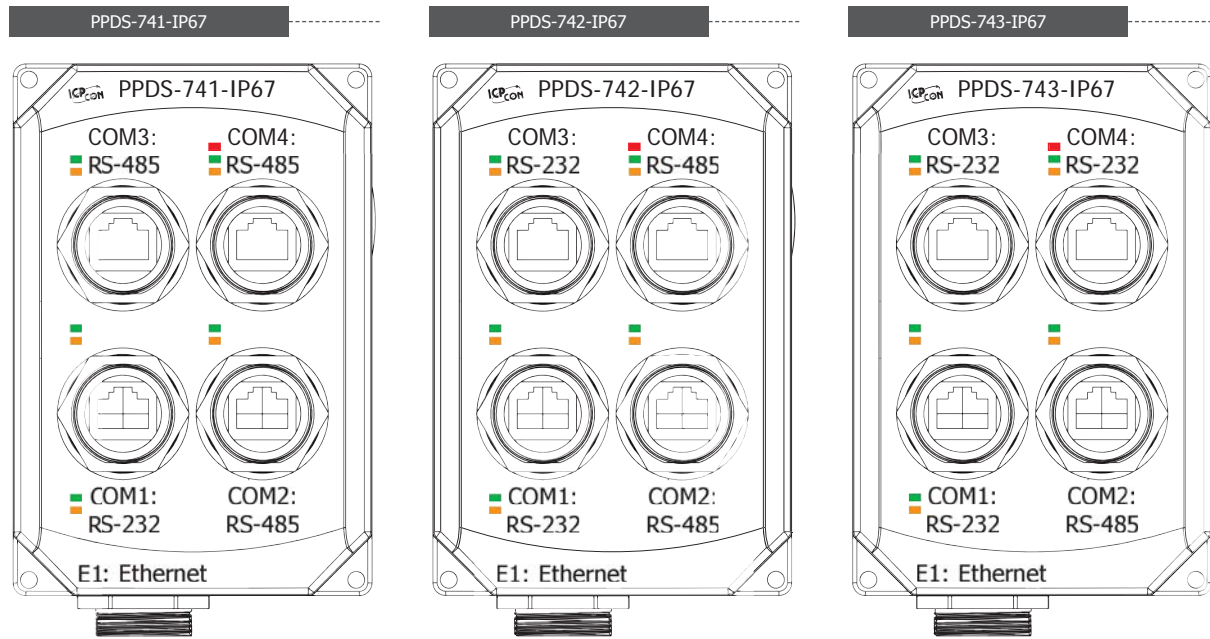

COM1 ~ COM4



Pin	5-wire RS-232	2-wire RS-485
1		
2	RTS	--
3	GND	GND
4	TxD	--
5	RxD	DATA+
6	--	DATA-
7	CTS	--
8		

DC +12 ~ +48 V_{DC}

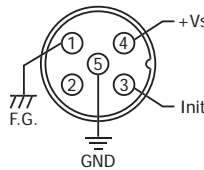

Pin	Name
1	F.G.
2	--
3	Init
4	+Vs
5	GND

LED Indicators

System	Color	Function
System	Red	Sys.
Ethernet	Green	Link/Act (E1)
	Orange	10/100M (E1)
COM1 ~ COM4	Green	RxD
	Orange	TxD

Ordering Information

PPDS-741-IP67 CR	Programmable Device Server with 1 RS-232 port, 3 RS-485 ports, PoE and IP67 Casing (RoHS)
PPDS-741-IP67/DIN CR	Programmable Device Server with 1 RS-232 port, 3 RS-485 ports, PoE, IP67 Casing and DIN-Rail Mounting (RoHS)
PPDS-742-IP67 CR	Programmable Device Server with 2 RS-232 ports, 2 RS-485 ports, PoE and IP67 Casing (RoHS)
PPDS-742-IP67/DIN CR	Programmable Device Server with 2 RS-232 ports, 2 RS-485 ports, PoE, IP67 Casing and DIN-Rail Mounting (RoHS)
PPDS-743-IP67 CR	Programmable Device Server with 3 RS-232 ports, 1 RS-485 port, PoE and IP67 Casing (RoHS)
PPDS-743-IP67/DIN CR	Programmable Device Server with 3 RS-232 ports, 1 RS-485 port, PoE, IP67 Casing and DIN-Rail Mounting (RoHS)

Accessories

GPSU06U-6	24 V _{DC} /0.25 A, 6 W Power Supply
MDR-20-24	24 V _{DC} /1 A, 24 W Power Supply with DIN-Rail Mounting
DIN-KA52F-48	48 V _{DC} /0.52 A, 25 W Power Supply with DIN-Rail Mounting
NS-205 CR	Unmanaged 5-port Industrial Ethernet Switch (RoHS)
NS-205PSE CR	Unmanaged Ethernet Switch with 4 PoE Ports and 1 RJ-45 Uplink (RoHS)

3-5 Modular Programmable Serial-to-Ethernet Device Server

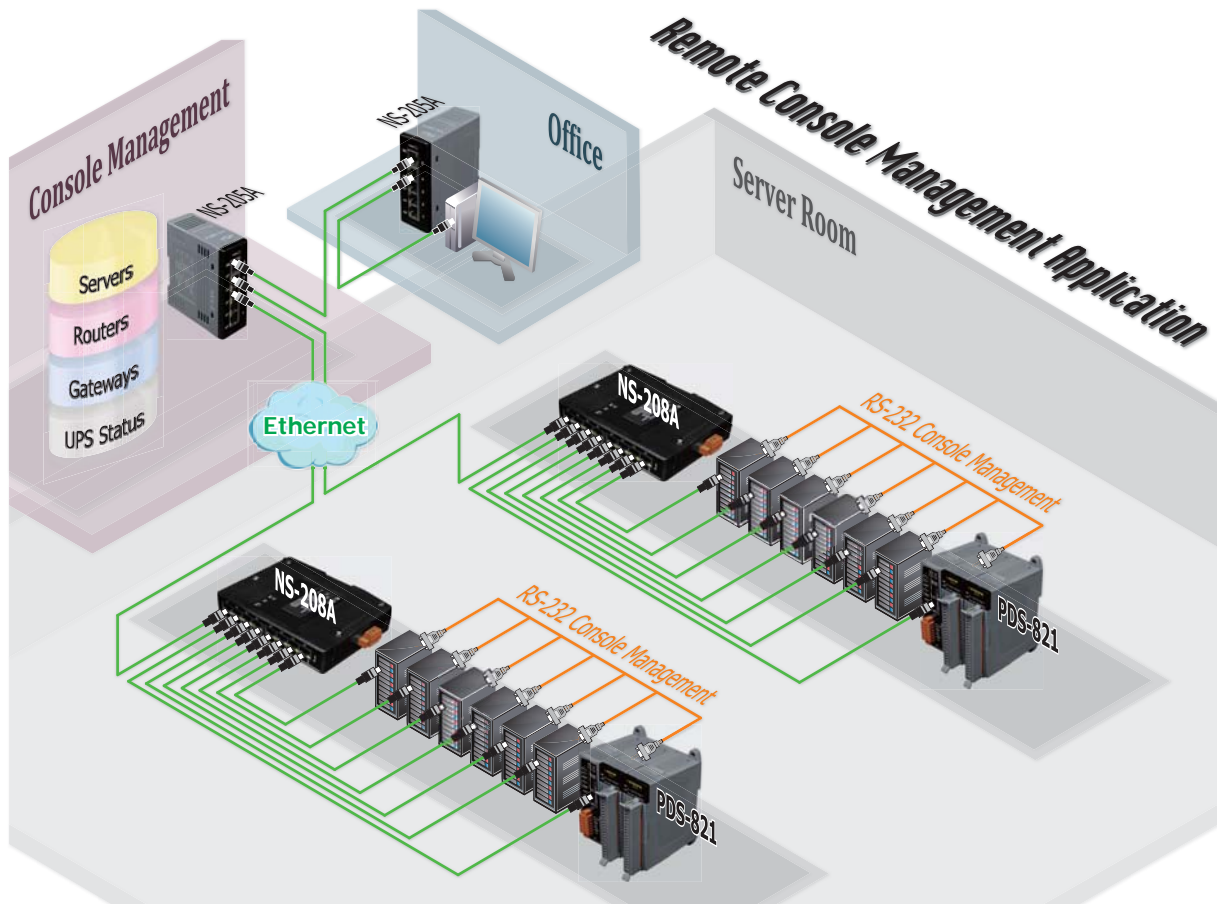

3

5

Serial Device Server

• Selection Guide

Model Name	Slots	CPU	RAM/ Flash Disk	Ethernet	Operating System	Console Port	(Optional) Max. Serial Ports	Page
PDS-811	1	80186, 80 MHz	512 KB/ 512 KB	2-port Ethernet Switch	MiniOS7	3-wire RS-232	4	3-5-2
PDS-821	2	80186, 80 MHz	512 KB/ 512 KB	2-port Ethernet Switch	MiniOS7	3-wire RS-232	8	3-5-2
PDS-842	4	PXA270, 520 MHz	64 MB/ 64 MB	Dual 10/100 M Ethernet	Linux	3-wire RS-232	16	3-5-4
PDS-882	8	PXA270, 520 MHz	64 MB/ 64 MB	Dual 10/100 M Ethernet	Linux	3-wire RS-232	32	3-5-4

• Optional Serial Modules

Model Name	Interface	Ports	FIFO	Isolation	Self-Tuner	Connector	Page
I-8112iW	9-wire RS-232	2	128 Bytes	2500 V _{rms}	–	DB-9	3-5-6
I-8114W	9-wire RS-232	4	128 Bytes	–	–	DB-37	3-5-8
I-8114iW	5-wire RS-232	4	128 Bytes	2500 V _{rms}	–	DB-37	3-5-8
I-8142iW	4-wire RS-422 2-wire RS-485	2	128 Bytes	2500 V _{rms}	Yes	Terminal Block	3-5-10
I-8144iW	4-wire RS-422 2-wire RS-485	4	128 Bytes	2500 V _{rms}	Yes	Terminal Block	3-5-10

PDS-811

PDS-821

Programmable Device Server with I/O Expansion Slot(s)



PDS-811

PDS-821



Features ▶▶▶

- Incorporate Serial Devices in an Ethernet network
- Virtual COM for 32-bit and 64-bit Windows XP/2003/Vista/7
- Watchdog Timer suitable for use in harsh environments
- 2-port 10/100 Base-TX Ethernet Switch (Auto-negotiating, auto MDI/MDI-X, LED indicator)
- ESD Protection and Frame Ground Design
- Built-in High Performance MiniOS7 from ICP DAS
- Made from fire-retardant materials (UL94-V0 Level)
- "Virtual COM" extends PC COM ports
- Programmable Internet/Ethernet Controller
- Power Reverse Polarity Protection
- 3-wire RS-232 Console Port
- RS-232 TxD/RxD LED Indicators
- System Status LED Indicator
- RoHS Compliant & no Halogen
- Low power consumption

Introduction

The PDS-811 and PDS-821 programmable device servers (PDS) are compact, modular, intelligent, rugged, and are designed for networking RS-232 and RS-422/485 serial devices to an Ethernet network. The PDS-811 has one I/O expansion slot, while PDS-821 has two I/O expansion slots that can be used to attach various 2- or 4-port serial communication modules. Therefore, a maximum of 4 serial ports can be installed on the PDS-811 or a maximum of 8 serial ports can be installed on the PDS-821.



Note: There is no serial module built-in to the PDS-811 or PDS-821 by default.

The PDS-811 and PDS-821 controllers are equipped with a 2-port 10/100 Base-TX Ethernet Switch that can be used to connect two network segments. The Ethernet Switch processes and routes data on the data-link layer (layer 2) of the OSI model to create a different collision domain per switch port. Using a switch allows you to attain dedicated bandwidth on point-to-point connections with every computer, and therefore run in full duplex mode with no collisions. Furthermore, the built-in 2-port Ethernet Switch on the PDS-811/821 enables network wiring to be simplified by cascading your Ethernet devices.

The PDS-8x1 series contains a built-in operating system, the MiniOS7, which offers a stable and high performance environment that is similar to DOS. The MiniOS7 can boot up the PDS-8x1 series within just one second, with the added benefit of no virus problems and a small footprint. Furthermore, the PDS-8x1 series is designed for low power consumption, maintenance elimination (no hard disk and no fan), and is constructed from fire-retardant materials (UL94-V0 level) with a robust case.



Applications

- Factory, Building and Home Automation

System Specifications

Models	PDS-811	PDS-821
CPU		
CPU	80186, 80 MHz or compatible	
SRAM	512 KB	
Flash Memory	512 KB	
EEPROM	16 KB	
NVRAM	-	
RTC (Real Time Clock)	-	
64-bit Hardware Serial Number	-	
Built-in Watchdog Timer	Yes	
I/O Expansion Slots	1 Slot	2 Slots
Communication Interface		
COM1 (Console)	RS-232 (TxD, RxD, GND)	
Ethernet	2-port 10/100 Base-TX Ethernet Switch (Auto-negotiating, auto MDI/MDI-X, LED indicator)	
COM Port Formats		
Speed	115200 bps max.	
Data Bit	7, 8	
Parity	None, Even, Odd	
Stop Bit	1	
LED Indicators		
TxD/RxD	Yes (for COM1 console port)	
System	Yes	
Power		
ESD Protection	Yes (with Frame Ground)	
Protection	Power Reverse Polarity Protection	
Required Supply Voltage	+10 Vdc ~ +30 Vdc (non-regulated)	
Power Consumption	0.6 A @ 5 V for CPU and Backplane, 1.0 A @ 5 V for Plug-in Modules, Total: 8 W	
Mechanical		
Flammability	Fire-Retardant Materials (UL94-V0 Level)	
Dimensions (W x L x H)	64 mm x 110 mm x 120 mm	95 mm x 110 mm x 132 mm
Installation	DIN-Rail mounting	DIN-Rail or Wall mounting
Environment		
Operating Temperature	-25 °C ~ +75 °C	
Storage Temperature	-40 °C ~ +80 °C	
Humidity	5 ~ 95% RH, non-condensing	

Dimensions (Unit: mm)

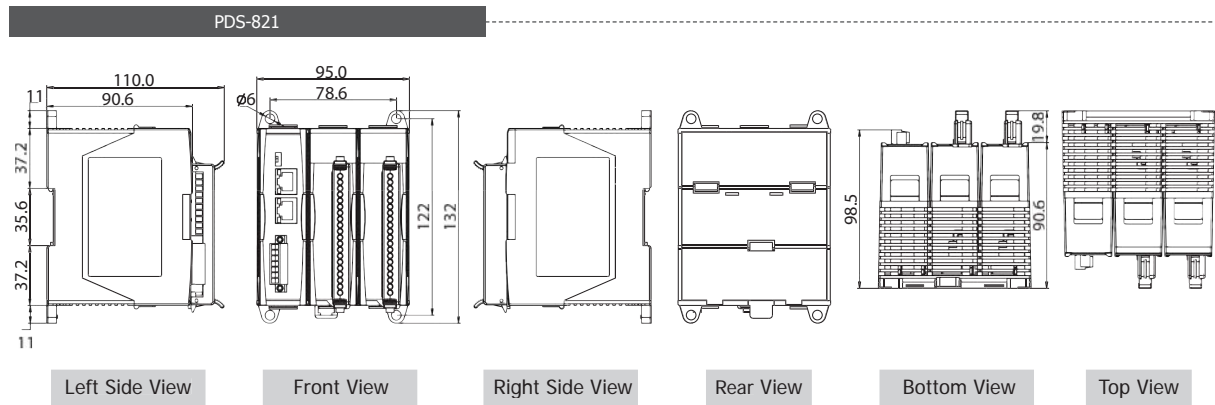
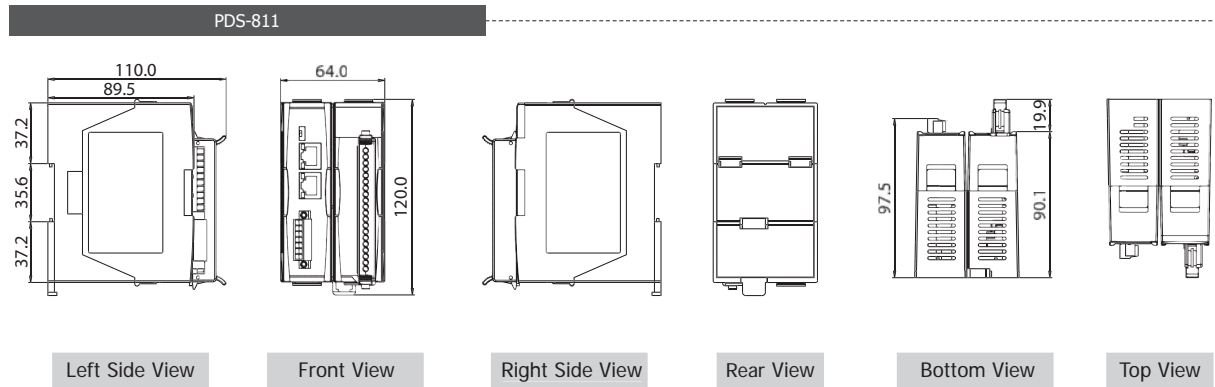

Pin Assignments

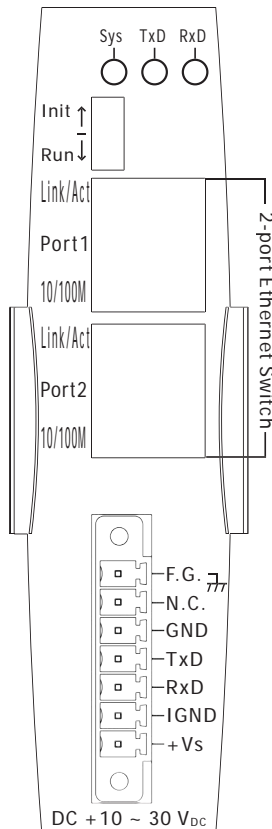

Ordering Information

PDS-811 CR	Programmable Device Server with 1 Expansion Slot (RoHS). Includes One CA-0910 Cable.
PDS-821 CR	Programmable Device Server with 2 Expansion Slots (RoHS). Includes One CA-0910 Cable.

Accessories

CA-0910	9-Pin Female D-Sub & 3-wire RS-232 Cable, 1 m Cable
MDR-20-24	24 Vdc/1 A, 24 W Power Supply with DIN-Rail Mounting
NS-205 CR	Unmanaged 5-port Industrial Ethernet Switch (RoHS)

PDS-842 *NEW*

PDS-882 *NEW*

Programmable Device Server with I/O Expansion Slot(s)



PDS-882



PDS-842

Features ▶▶▶

- Linux kernel 2.6.19 Inside
- Standard PDS-8x2 SDK for Windows and Linux operating systems
- Virtual COM for 32-bit and 64-bit Windows XP/2003/Vista/7
- Watchdog Timer suitable for use in harsh environments
- Dual-LAN, 10/100 Base-TX Ethernet (Auto-negotiating, auto MDI/MDI-X, LED indicator)
- Made from fire-retardant materials (UL94-V0 Level)
- Incorporate Serial Devices in an Ethernet network
- "Virtual COM" extends PC COM ports
- Programmable Internet/Ethernet Controller
- Power Reverse Polarity Protection
- DB-9 RS-232 console port
- ESD Protection and Frame Ground Design
- Low power consumption

Introduction

The PDS-842 and PDS-882 programmable device servers (PDS) are compact, modular, intelligent, rugged, and are designed for networking RS-232/422/485 serial devices to an Ethernet network. The PDS-842 has 4 I/O expansion slots, while the PDS-882 has 8 I/O expansion slots that can be used to attach various 2- or 4-port serial communication modules. Therefore, a maximum of 16 serial ports can be installed on the PDS-842 or a maximum of 32 serial ports can be installed on the PDS-882.



By using the PDS-842 or PDS-882, users can transparently access serial devices over the Internet.

This PDS, coupled with a large built-in RAM buffer, allows for fast transmission and prevents congestion of serial data on the network. A built-in powerful 32-bit RISC processor offers exceptional performance at low power consumption.

The PDS-842 and PDS-882 provides two Ethernet ports, which can be used to implement redundant Ethernet communication and separate Ethernet communication (one for global Internet, one for private Ethernet). To prevent the PDS-842 and PDS-882 from failing due to power loss, the power module is designed with two inputs, so that the module can continue working even if one power input fails, and, meanwhile, there is a relay output available for informing users about the power failure.

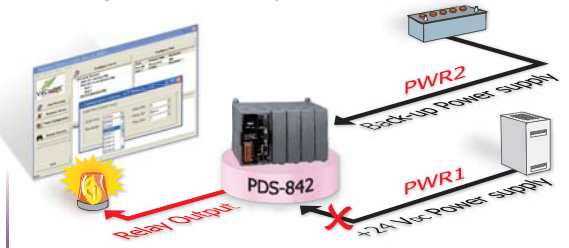

Applications

- Factory, Building and Home Automation

System Specifications

Models	PDS-842	PDS-882
CPU		
CPU	PXA270 or compatible (32-bit and 520 MHz)	
SRAM	64 MB	
Flash Memory	64 MB	
EEPROM	16 KB	
NVRAM	-	
RTC (Real Time Clock)	No	
64-bit Hardware Serial Number	Yes	
Built-in Watchdog Timer	Yes	
I/O Expansion Slots	4 Slots	8 Slots
Programmable LED Indicator	1	
Communication Interface		
COM1 (Console)	RS-232 (TXD, RXD, GND)	
COM2	RS-485 (D+, D-); 3000 Vdc isolated	
Ethernet	RJ-45 x 2, Dual 10/100 Base-TX Ethernet Controller (Auto-negotiating, auto MDI/MDI-X, LED indicator)	
COM Port Formats		
Speed	115200 bps max.	
Data Bit	7, 8	
Parity	None, Even, Odd	
Stop Bit	1	
Power		
ESD Protection	Yes (with Frame Ground)	
Protection	Power Reverse Polarity Protection	
Redundant Power Inputs	Yes, with one relay for warning alarm	
Required Supply Voltage	+18 Vdc ~ +48 Vdc (non-regulated)	
Power Consumption	8.4 W (0.35 A @ 24 Vdc)	9.1 W (0.38 A @ 24 Vdc)
Mechanical		
Flammability	Fire-Retardant Materials (UL94-V0 Level)	
Dimensions (W x L x H)	188 mm x 132 mm x 111 mm	312 mm x 132 mm x 111 mm
Installation	DIN-Rail or Wall mounting	
Environment		
Operating Temperature	-25 °C ~ +75 °C	
Storage Temperature	-30 °C ~ +85 °C	
Humidity	5 ~ 95% RH, non-condensing	

Dimensions (Unit: mm)

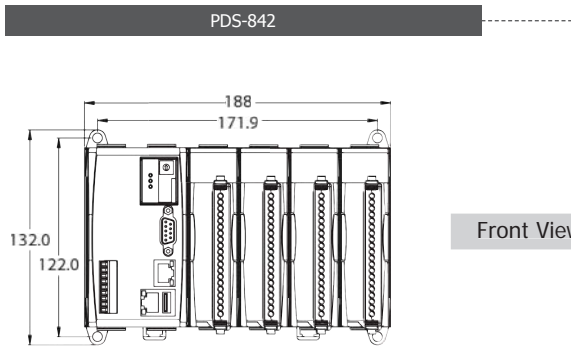

Front View

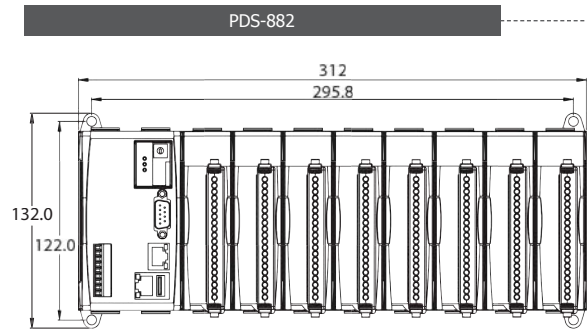

Bottom View

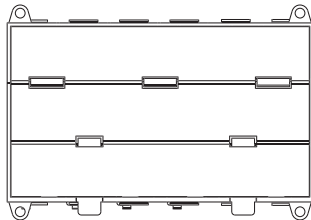
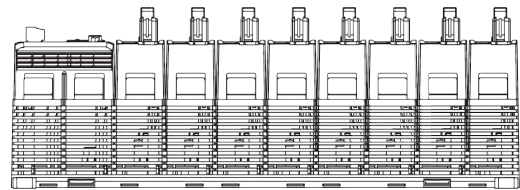
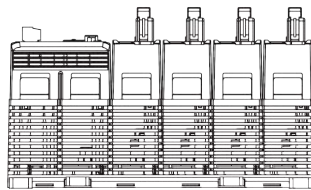

Rear View

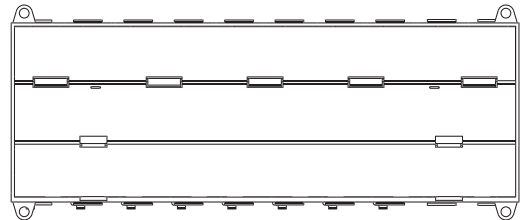

Pin Assignments

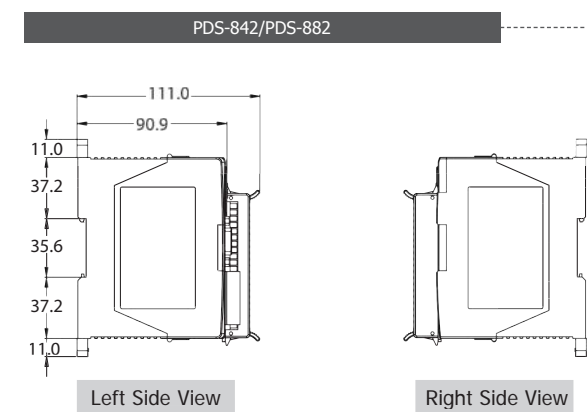
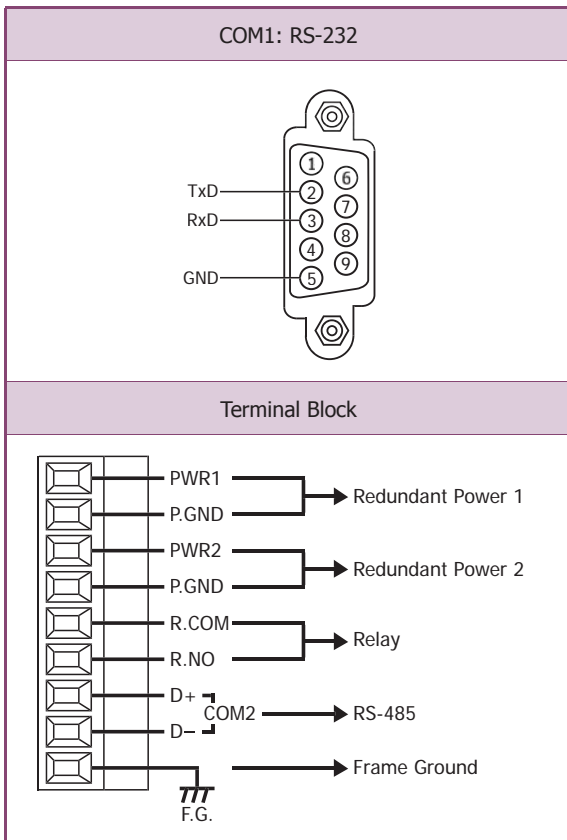

Ordering Information

PDS-842 CR	Programmable Device Server with 4 Expansion Slots (RoHS).
PDS-882 CR	Programmable Device Server with 8 Expansion Slots (RoHS).

Accessories

KA-52F	24 Vdc/1.04 A, 25 W Power Supply
DIN-KA52F	24 Vdc/1.04 A, 25 W Power Supply with DIN-Rail Mounting
MDR-60-24	24 Vdc/2.5 A, 60 W Power Supply with DIN-Rail Mounting
CA-0915	9-Pin Male-Female D-Sub Cable, 1.5 m Cable
NS-205 CR	Unmanaged 5-port Industrial Ethernet Switch (RoHS)

I-8112iW-G *NEW*

2-port Isolated RS-232 Module



Features ▶▶▶

- High-profile Module
- Serial Port with +/-4 kV ESD Protection
- Baud Rate of up to 115200 bps
- Low power consumption
- Made from fire-retardant materials (UL94-V0 Level)
- 2500 V_{rms} Isolation
- Internal 128-byte Hardware FIFO for each Port
- LED Indicators for TxD, RxD and Power Status
- RoHS Compliant & no Halogen

Introduction

The I-8112iW-G provides 2 isolated RS-232 serial ports. It is equipped with a 128-byte hardware FIFO for each port and offers speeds up to 115.2 kbps with support for full-duplex communication.

In the harsh industrial environment, the onboard ESD protection devices can divert this potentially damaging charge away from sensitive circuitry and protect the I-8112iW from permanent damage.

The serial communication modules are designed for use with intelligent devices like bar code readers, serial printers, intelligent sensors, instrumentation equipment, computers, and almost any device with an RS-232 port.

Applications

- Factory Automation
- Building Automation
- Home Automation

Software

- Supports interrupt driven software library
- Supports VxCOM library

System Specifications

LED Indicators	
Power	1 LED
TxD	2 LEDs
RxD	2 LEDs
Power	
Power Consumption	1.5 W
Mechanical	
Dimensions (W x L x H)	31 mm x 86 mm x 114 mm
Environment	
Operating Temperature	-25 °C ~ +75 °C
Storage Temperature	-30 °C ~ +80 °C
Humidity	10 ~ 95% RH, non-condensing

I/O Specifications

RS-232 Interface	
Number of Ports	2
Interface	TxD, RxD, RTS, CTS, DSR, DTR, DCD, RI, GND
Controller	16C950 Compatible
	Speed: 115200 bps max.
	Data Bit: 5, 6, 7, 8
	Stop Bit: 1, 1.5, 2
	Parity: None, Even, Odd, Mark, Space
	FIFO: Internal 128 bytes for each port
Interrupt	Shared Interrupt
Bus	Parallel I/O Module
Connector	DB-9 (Male)
Intra-module Isolated, Field to Logic	2500 V _{rms}
ESD Protection	+/-4 kV (Contact for each channel)

Wiring

DTE Device (Computer)			DTE to DCE Connections		DCE Device (Modem)		
Pin#	DB9	RS-232 Signal Names	Signal Direction		Pin#	DB9	RS-232 Signal Names
#1	Carrier Detector	DCD	←	→	#1	Carrier Detector	DCD
#2	Receive Data	RxD	←	→	#2	Transmit Data	TxD
#3	Transmit Data	TxD	→	←	#3	Receive Data	RxD
#4	Data Terminal Ready	DTR	→	←	#4	Data Set Ready	DSR
#5	Signal Ground/Common (SG)	GND	→	←	#5	Signal Ground/Common (SG)	GND
#6	Data Set Ready	DSR	→	←	#6	Data Terminal Ready	DTR
#7	Request to Send	RTS	→	←	#7	Clear to Send	CTS
#8	Clear to Send	CTS	→	←	#8	Request to Send	RTS
#9	Ring Indicator	RI	→	←	#9	Ring Indicator	RI
Soldered to DB9 Metal-Shield		FGND	→	←	Soldered to DB9 Metal-Shield		FGND

3-wire RS-232 Wiring

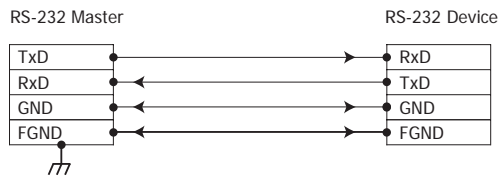

Pin Assignments

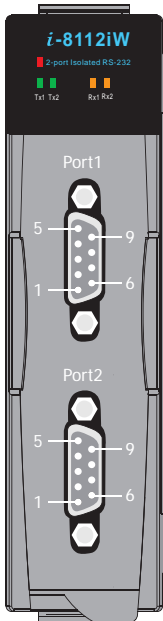

Pin Assignment	Terminal	No.	Pin Assignment
GND1	05	09	RI1
DTR1	04	08	CTS1
TxD1	03	07	RTS1
RxD1	02	06	DSR1
DCD1	01		



Pin Assignment	Terminal	No.	Pin Assignment
GND2	05	09	RI1
DTR2	04	08	CTS2
TxD2	03	07	RTS2
RxD2	02	06	DSR2
DCD2	01		

Dimensions (Unit: mm)

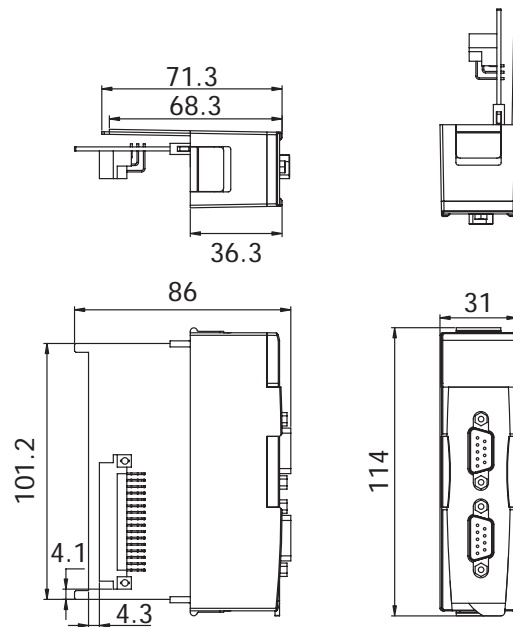

Ordering Information

I-8112iW-G CR	2-port Isolated RS-232 Module (RoHS)
---------------	--------------------------------------

Accessories

CA-0915	9-Pin Male-Female D-Sub Cable, 1.5 m
---------	--------------------------------------

I-8114W-G *NEW*

4-port RS-232 Module

I-8114iW-G *NEW*

4-port Isolated RS-232 Module



I-8114W

I-8114iW



Features ▶▶▶▶

- High-profile Module
- Serial Port with +/-4 kV ESD Protection
- Baud Rate of up to 115200 bps
- Low power consumption
- Made from fire-retardant materials (UL94-V0 Level)
- 2500 V_{rms} Isolation for I-8114iW
- Internal 128-byte Hardware FIFO for each Port
- LED Indicators for TxD, RxD and Power Status
- RoHS Compliant & no Halogen

Introduction

The I-8114W-G provides 4 non-isolated RS-232 serial ports, while the I-8114iW-G provides 4 isolated RS-232 serial ports. It is equipped with a 128-byte hardware FIFO for each port and offers speeds up to 115.2 kbps with support for full-duplex communication.

In the harsh industrial environment, the onboard ESD protection devices can divert this potentially damaging charge away from sensitive circuitry and protect the I-8114W/I-8114iW from permanent damage.

The serial communication modules are designed for use with intelligent devices like bar code readers, serial printers, intelligent sensors, instrumentation equipment, computers, and almost any device with an RS-232 port.

Applications

- Factory Automation
- Building Automation
- Home Automation

Software

- Supports interrupt driven software library
- Supports VxCOM library

System Specifications

Models	I-8142W	I-8144iW
LED Indicators		
Power	1 LED	
TxD	4 LEDs	
RxD	4 LEDs	
Power		
Power Consumption	1.25 W	1.75 W
Mechanical		
Dimensions (W x L x H)	31 mm x 85 mm x 114 mm	
Environment		
Operating Temperature	-25 °C ~ +75 °C	
Storage Temperature	-30 °C ~ +80 °C	
Humidity	10 ~ 95% RH, non-condensing	

I/O Specifications

Models	I-8114W	I-8114iW
RS-232 Interface		
Number of Ports	4	
Interface	TxD, RxD, RTS, CTS, DSR, DTR, DCD, RI, GND	TxD, RxD, RTS, CTS, GND
Controller	16C950 Compatible	
	Speed: 115200 bps max.	
	Data Bit: 5, 6, 7, 8	
	Stop Bit: 1, 1.5, 2	
	Parity: None, Even, Odd, Mark, Space	
	FIFO: Internal 128 bytes for each port	
Interrupt	Shared Interrupt	
Bus	Parallel I/O Module	
Connector	DB-37 (Female)	
Intra-module Isolated, Field to Logic	-	2500 V _{rms}
ESD Protection	+/-4 kV (Contact for each channel)	

Wiring

DTE Device (Computer)			DTE to DCE Connections		DCE Device (Modem)		
Pin#	DB9	RS-232 Signal Names	Signal Direction		Pin#	DB9	RS-232 Signal Names
#1	Carrier Detector	DCD	←	→	#1	Carrier Detector	DCD
#2	Receive Data	RxD	←	→	#2	Transmit Data	TxD
#3	Transmit Data	TxD	→	←	#3	Receive Data	RxD
#4	Data Terminal Ready	DTR	→	←	#4	Data Set Ready	DSR
#5	Signal Ground/Common (SG)	GND	→	←	#5	Signal Ground/Common (SG)	GND
#6	Data Set Ready	DSR	→	←	#6	Data Terminal Ready	DTR
#7	Request to Send	RTS	→	←	#7	Clear to Send	CTS
#8	Clear to Send	CTS	→	←	#8	Request to Send	RTS
#9	Ring Indicator	RI	→	←	#9	Ring Indicator	RI
Soldered to DB9 Metal-Shield			→	←	Soldered to DB9 Metal-Shield		
		FGND					FGND

3-wire RS-232 Wiring

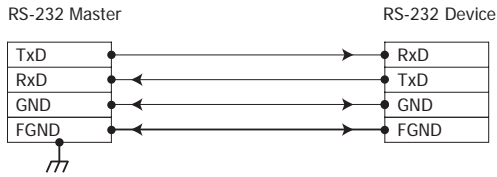

Pin Assignments

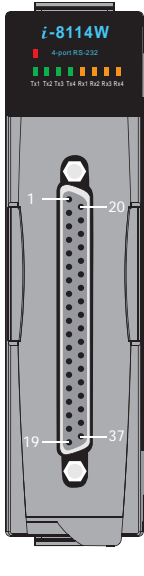

Pin Assignment	Terminal	No.	Pin Assignment
N.C.	01	20	RI3
DCD3	02	21	DTR3
GND3	03	22	DSR3
CTS3	04	23	RTS3
RxD3	05	24	TxD3
RI4	06	25	DCD4
DTR4	07	26	GND
DSR4	08	27	CTS4
RTS4	09	28	RxD4
TxD4	10	29	RI2
DCD2	11	30	DTR2
GND	12	31	DSR2
CTS2	13	32	RTS2
RxD2	14	33	TxD2
RI1	15	34	DCD1
DTR1	16	35	GND
DSR1	17	36	CTS1
RTS1	18	37	RxD1
TxD1	19		

37-Pin Female D-Sub Connector

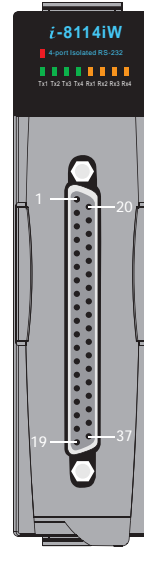

Pin Assignment	Terminal	No.	Pin Assignment
N.C.	01	20	N.C.
N.C.	02	21	N.C.
GND3	03	22	N.C.
CTS3	04	23	RTS3
RxD3	05	24	TxD3
N.C.	06	25	N.C.
N.C.	07	26	GND4
N.C.	08	27	CTS4
RTS4	09	28	RxD4
TxD4	10	29	N.C.
N.C.	11	30	N.C.
GND2	12	31	N.C.
CTS2	13	32	RTS2
RxD2	14	33	TxD2
N.C.	15	34	N.C.
N.C.	16	35	GND1
N.C.	17	36	CTS1
RTS1	18	37	RxD1
TxD1	19		

37-Pin Female D-Sub Connector

Dimensions (Unit: mm)

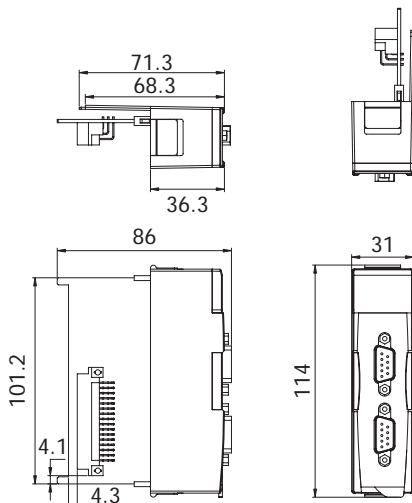

Ordering Information

I-8114W-G CR	4-port RS-232 Module (RoHS)
I-8114W-G/D2 CR	4-port RS-232 Module (RoHS) Includes One CA-9-3705 Cable
I-8114iW-G CR	4-port Isolated RS-232 Module (RoHS)
I-8114iW-G/D2 CR	4-port Isolated RS-232 Module (RoHS) Includes One CA-9-3705 Cable

Accessories

CA-4002	37-Pin Male D-Sub Connector with Plastic Cover
CA-9-3705	DB-37 Male (D-Sub) to 4-port DB-9 Male (D-Sub) Cable 0.3 m Cable for I-8114W-G/I-8114iW-G (90°)

I-8142iW-G *NEW*

2-port Isolated RS-422/485 Module

I-8144iW-G *NEW*

4-port Isolated RS-422/485 Module



I-8142iW

I-8144iW



Features ▶▶▶

- High-profile Module
- Serial Port with +/-4 kV ESD Protection
- Baud Rate of up to 115200 bps
- Built-in Self-Tuner or Auto-Direction Control
- Low power consumption
- 2500 V_{rms} Isolation
- Internal 128-byte Hardware FIFO for each Port
- LED Indicators for TxD, RxD and Power Status
- RoHS Compliant & no Halogen
- Made from fire-retardant materials (UL94-V0 Level)

Introduction

The I-8142iW-G provides 2 isolated RS-422/485 serial ports, while the I-8144iW-G provides 4 isolated RS-422/485 serial ports. It is equipped with a 128-byte hardware FIFO for each port and offers speeds up to 115.2 kbps with support for RS-422 full-duplex communication.

In the harsh industrial environment, the onboard ESD protection devices can divert this potentially damaging charge away from sensitive circuitry and protect the I-8142iW/I-8144iW from permanent damage.

The serial communication modules are designed for use with intelligent devices like bar code readers, serial printers, intelligent sensors, instrumentation equipment, computers, and almost any device with an RS-422/485 port.

Applications

- Factory, Building and Home Automation

Software

- Supports interrupt driven software library
- Supports VxCOM library

System Specifications

Models	I-8142W	I-8144iW
LED Indicators		
Power	1 LED	
TxD	2 LEDs	4 LEDs
RxD	2 LEDs	4 LEDs
Power		
Power Consumption	1.5 W (Without Resistor) 2 W (With 2 Resistors, 1/4 Watt, 120 Ω 5%)	1.75 W (Without Resistor) 3 W (With 4 Resistors, 1/4 Watt, 120 Ω 5%)
Mechanical		
Dimensions (W x L x H)	30 mm x 102 mm x 115 mm	
Environment		
Operating Temperature	-25 °C ~ +75 °C	
Storage Temperature	-30 °C ~ +80 °C	
Humidity	10 ~ 95% RH, non-condensing	

I/O Specifications

Models	I-8142iW	I-8144iW
RS-422/485 Interface		
Number of Ports	2	4
Interface	Isolated RS-422/485 (The RS-422 and RS-485 can not be used simultaneously) RS-422: TxD+, TxD-, RxD+, RxD-, GND RS-485: D+, D-, GND	
2-wire Cabling/ 4-wire Cabling	Belden 9841 (2P twisted-pair cable)/ Belden 9842 (4P twisted-pair cable), If different cables are used, the transmission distance may change	
Transfer Distance	Max. of 1,200 m at 9.6 kbps; Max. of 400 m at 115.2 kbps	
4-wire Cabling	Max. of 256 devices. in a single RS-485 network without using a repeater	
Controller	16C950 Compatible	
	Speed: 115200 bps max.	
	Data Bit: 5, 6, 7, 8	
	Stop Bit: 1, 1.5, 2	
	Parity: None, Even, Odd, Mark, Space	
	FIFO: Internal 128 bytes for each port	
Self-Tuner Asic inside	Yes	
Interrupt	Shared Interrupt	
Bus	Parallel I/O Module	
Connector	Removable 20-Pin Terminal Block	
Intra-module Isolated, Field to Logic	2500 V _{rms}	
ESD Protection	+/-4 kV (Contact for each channel)	

Wiring

2-wire RS-485 Wiring

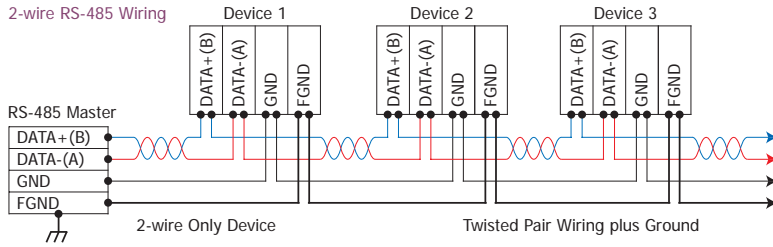

4-wire RS-422 Wiring

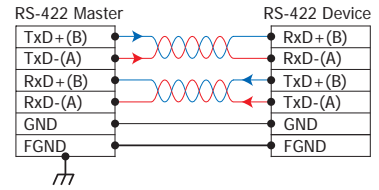

Pin Assignments

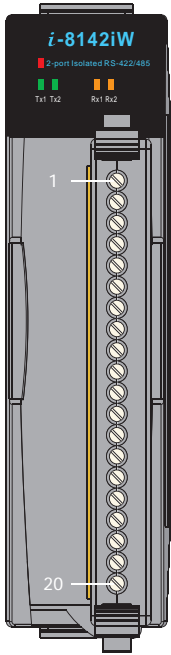

Terminal No.	Pin Assignment
01	D1+/TxD1+
02	D1-/TxD1-
03	RxD1+
04	RxD1-
05	GND1
06	D2+/TxD2+
07	D2-/TxD2-
08	RxD2+
09	RxD2-
10	GND2
11	N.C.
12	N.C.
13	N.C.
14	N.C.
15	N.C.
16	N.C.
17	N.C.
18	N.C.
19	N.C.
20	N.C.

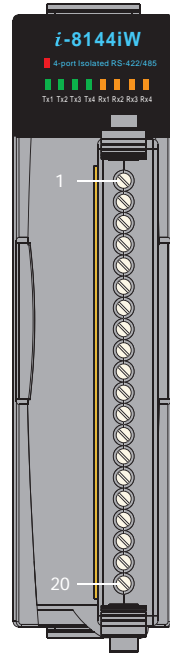

Terminal No.	Pin Assignment
01	D1+/TxD1+
02	D1-/TxD1-
03	RxD1+
04	RxD1-
05	GND1
06	D2+/TxD2+
07	D2-/TxD2-
08	RxD2+
09	RxD2-
10	GND2
11	D3+/TxD3+
12	D3-/TxD3-
13	RxD3+
14	RxD3-
15	GND3
16	D4+/TxD4+
17	D4-/TxD4-
18	RxD4+
19	RxD4-
20	GND4

Dimensions (Unit: mm)

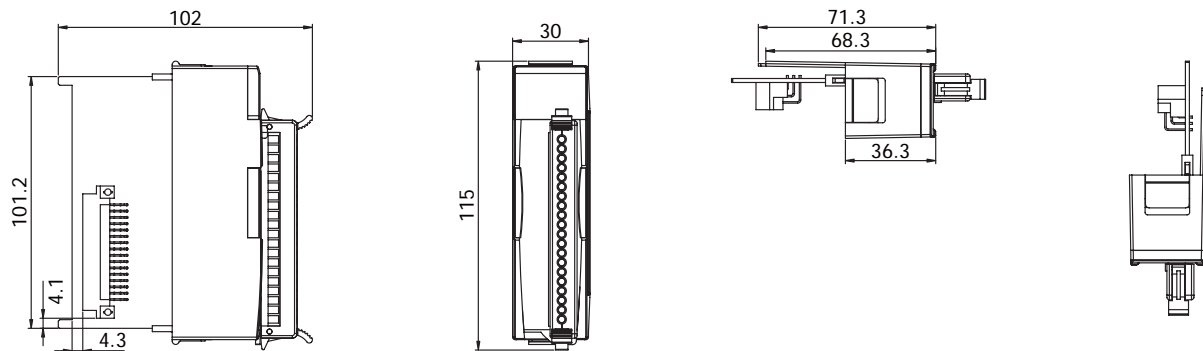

Ordering Information

I-8142iW-G CR	2-port Isolated RS-422/485 Module (RoHS)
I-8144iW-G CR	4-port Isolated RS-422/485 Module (RoHS)

Accessories

CA-4002	37-Pin Male D-Sub Connector with Plastic Cover
CA-9-3705	DB-37 Male (D-Sub) to 4-port DB-9 Male (D-Sub) Cable 0.3 m Cable for I-8114W-G/I-8114iW-G (90°)

3-6 Programmable Serial-to-Fiber Device Server

PDS-220Fx *NEW*

Programmable Device Server with 1 RS-232, 1 RS-422/485 and 1 Fiber ports



PDS-220FT



PDS-220FC
PDS-220FCS
PDS-220FCS-60

Features ▶▶▶▶

- Adds optical fiber connectivity to serial devices
- Virtual COM for 32-bit and 64-bit Windows XP/2003/Vista/7
- Watchdog Timer suitable for use in harsh environments
- Serial Port +/-4 kV ESD Protection Circuit
- RoHS Compliant & no Halogen
- 100 Base-FX (SC/ST connector)
- Low power consumption
- "Virtual COM" extends PC COM ports
- Powerful Programmable Device Server
- Power Reverse Polarity Protection
- Self-tuner ASIC Controller on the RS-485 port
- Built-in high performance MiniOS7 from ICP DAS
- ODM Service is available
- Made from fire-retardant materials (UL94-V0 level)

Introduction

The PDS-220Fx series is a family of Programmable Device Servers, also known as "Serial-to-Fiber gateway", that are designed for adding optical fiber connectivity to RS-232/422/485 devices.

The fiber-optic communications permits transmission over longer distances than other forms of communications because of the signals travel along them with less loss and no crosstalk. It has following important features:

- Immunity to electromagnetic interference (EMI) — Motors, relays, welders and other industrial equipment generate a tremendous amount of electrical noise that can cause major problems with copper cabling.
- High electrical resistance, making it safe to use near high voltage equipment or between areas with different earth potentials.
- No sparks — important in flammable or explosive gas environments.
- Not electromagnetically radiating, and difficult to tap without disrupting the signal — important in high-security environments.

Because of these reasons, optical fibers have largely replaced copper wire communications in core networks in the developed world.

The user-friendly VxComm Driver/Utility allows users to easily turn the built-in COM ports of the PDS-220Fx series into standard COM ports on a PC. By virtue of its protocol independence, a small-core OS and high flexibility, the PDS-220Fx series is able to meet the demands of every network-enabled application.

The PDS-220Fx series includes a powerful and reliable Xserver programming structure that allows you to design your robust Ethernet applications in one day. The built-in, high-performance MiniOS7 boots the PDS-220Fx up in just one second and gives you your fastest responses.

The PDS-220Fx is equipped with 1 RS-232 port and 1 RS-422/485 port. The removable onboard terminal block connector is designed for easy and robust wiring in industrial situations.

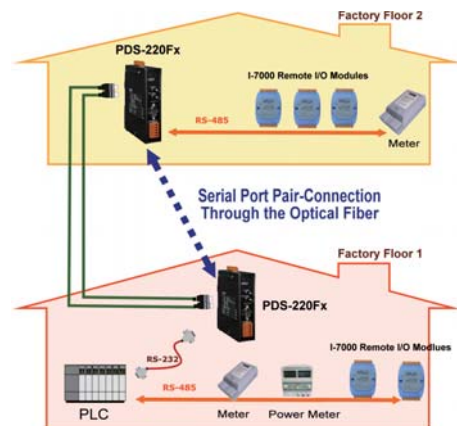
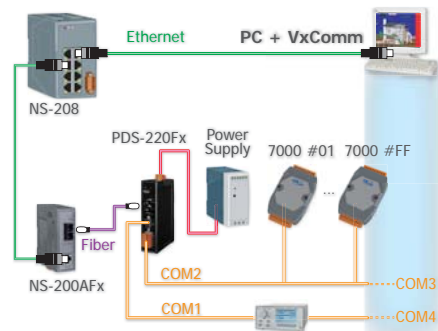



Applications

Factory Automation

Building Automation

Home Automation

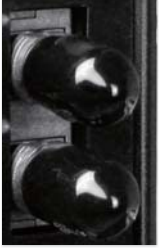
System Specifications

Models	PDS-220FT	PDS-220FC	PDS-220FCS	PDS-220FCS-60	
CPU					
CPU	80186, 80 MHz or compatible				
SRAM	512 KB				
Flash	512 KB; Erase unit is one sector (64 KB); 100,000 erase/write cycles				
EEPROM	16 KB; Data retention: 40 years; 1,000,000 erase/write cycles				
Built-in Watchdog Timer	Yes				
Init Pin	Yes				
Communication Interface					
COM1	Male DB-9, 5-wire RS-232 (RxD, TxD, CTS, RTS, GND); Note: +/- 4 kV ESD Protection				
COM2	Removable Terminal Block 2-wire RS-485 (D+, D-, GND) with Self-Tuner ASIC or 4-wire RS-422 (TxD+, TxD-, RxD+, RxD-, GND) Note: +/- 4 kV ESD Protection				
Fiber Port	100 Base-FX, ST connector		100 Base-FX, SC connector		
					
Mode	Fiber Cables	Multi-mode: 50/125, 62.5/125 or 100/140 μm		Single-mode: 8.3/125, 8.7/125, 9/125 or 10/125 μm	
	Wavelength	1300 or 1310 nm			
	Min. TX Output	-20 dBm		-15 dBm	-5 dBm
	Max. TX Output	-14 dBm		-8 dBm	-0 dBm
	Max. RX Sensitivity	-32 dBm		-34 dBm	-35 dBm
	Min. RX Overload	-8 dBm		-5 dBm	
	Budget	12 dBm		19 dBm	30 dBm
Distance	2 km, (62.5/125 μm recommended) for full duplex		30 km , (9/125 μm recommended) for full duplex	60 km , (9/125 μm recommended) for full duplex	
COM Port Formats					
UART	16C550 or compatible				
Data Bit	7, 8				
Parity	None, Even, Odd, Mark, Space				
Stop Bit	1, 2				
Baud Rate	115200 bps max.				
LED Indicators					
Link/Act	Green				
System	Red				
Power					
Power Input	+12 V _{DC} ~ +48 V _{DC} (non-regulated)				
Power Consumption	0.14 A @ 24 V _{DC}				
Protection	Power Reverse Polarity Protection				
Frame GND	Yes, for EMS Protection				
Mechanical					
Flammability	Fire-Retardant Materials (UL94-V0 Level)				
Dimensions (W x L x H)	31 mm x 121 mm x 157 mm		31 mm x 123 mm x 157 mm		
Installation	DIN-Rail mounting				
Environment					
Operating Temperature	-25 °C ~ +75 °C				
Storage Temperature	-30 °C ~ +85 °C				
Humidity	10 ~ 90% RH, non-condensing				

Pin Assignments

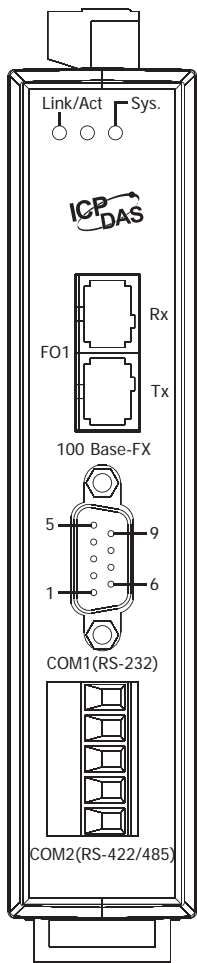

Pin Assignment	Terminal No.	Terminal No.	Pin Assignment
GND	05	09	--
--	04	08	CTS
TxD	03	07	RTS
RxD	02	06	--
--	01		

COM1: Male DB-9 Connector

Terminal No.	Pin Assignment
01	TxD+/D+
02	TxD-/D-
03	RxD+
04	RxD-
05	GND

COM2: Removable Terminal Block

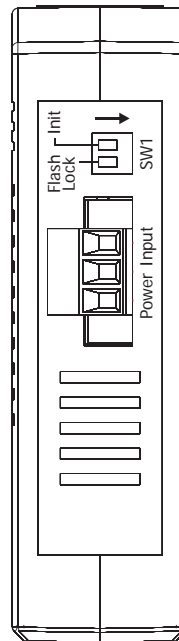

Terminal No.	Pin Assignment
03	PWR
02	P.GND
01	F.G.

Power Input: Removable Terminal Block

Ordering Information

PDS-220FT CR	Programmable Device Server with 1 RS-232, 1 RS-422/485 and 1 Multi-mode ST Fiber Port (RoHS)
PDS-220FC CR	Programmable Device Server with 1 RS-232, 1 RS-422/485 and 1 Multi-mode SC Fiber Port (RoHS)
PDS-220FCS CR	Programmable Device Server with 1 RS-232, 1 RS-422/485 and 1 Single-mode SC Fiber Port (RoHS)
PDS-220FCS-60 CR	Programmable Device Server with 1 RS-232, 1 RS-422/485 and 1 Single-mode SC Fiber Port (RoHS)

Accessories

GPSU06U-6 CR	24 V _{DC} /0.25 A, 6 W Power Supply
MDR-20-24 CR	24 V _{DC} /1 A, 24 W Power Supply with DIN-R
CA-0903	9-Pin Female D-Sub and RS-232 Connector Cable, 30 cm Cable
CA-0910	9-Pin Female D-Sub and 3-wire RS-232 Cable, 1 m Cable
NS-200AFT CR	Industrial 10/100 Base-T to 100 Base-FX Media Converter; 1 Multi-mode ST connector (RoHS)
NS-200AFC CR	Industrial 10/100 Base-T to 100 Base-FX Media Converter; 1 Multi-mode SC connector (RoHS)
NS-200AFCS CR	Industrial 10/100 Base-T to 100 Base-FX Media Converter; 1 Single-mode SC connector (RoHS)
NS-200AFCS-40T CR	Industrial 10/100 Base-T to 100 Base-FX Media Converter; 1 (40 km) Single-mode SC connector (RoHS)
NS-205 CR	Unmanaged 5-port Industrial Ethernet Switch (RoHS)
DIN-KA52F-48 CR	48V/0.52A, 25 W Power Supply with DIN-Rail Mounting (RoHS, for NS-205PSE)

3-7 Tiny Serial-to-Ethernet Device Server & Modbus Gateway

tDS-700 Series **NEW**

Tiny Serial-to-Ethernet Device Server

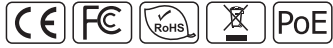

Features ▶▶▶

- Incorporates any RS-232/422/485 serial device in Ethernet
- VxComm Driver for 32/64-bit Windows XP/2003/Vista/7
- 10/100 Base-TX Ethernet, RJ-45 x1 (Auto-negotiating, auto MDI/MDIX, LED Indicators)
- Includes redundant power inputs: PoE and DC jack
- Allows easy firmware updates via the Ethernet
- Male DB-9 or terminal block connector for easy wiring
- RoHS Compliant & no Halogen
- Cost-effective Device Servers
- 32-bit MCU that efficiently handles network traffic
- Supports pair-connection (serial-bridge, serial-tunnel) applications
- Supports TCP, UDP, HTTP, DHCP, BOOTP and TFTP protocols
- Supports UDP responder for device discovery
- Allows automatic RS-485 direction control
- Provides an intuitive web configuration interface
- Tiny form-factor and low power consumption
- Made from fire-retardant materials (UL94-V0 Level)

Introduction

The tDS-700 is a series of Serial-to-Ethernet device servers designed to add Ethernet and Internet connectivity to any RS-232 and RS-422/485 device, and to eliminate the cable length limitation of legacy serial communication. By using the VxComm Driver/Utility, the built-in COM port of the tDS-700 series can be virtualized to a standard PC COM port in Windows. Therefore, users can transparently access or monitor serial devices over the Internet/Ethernet without software modification.

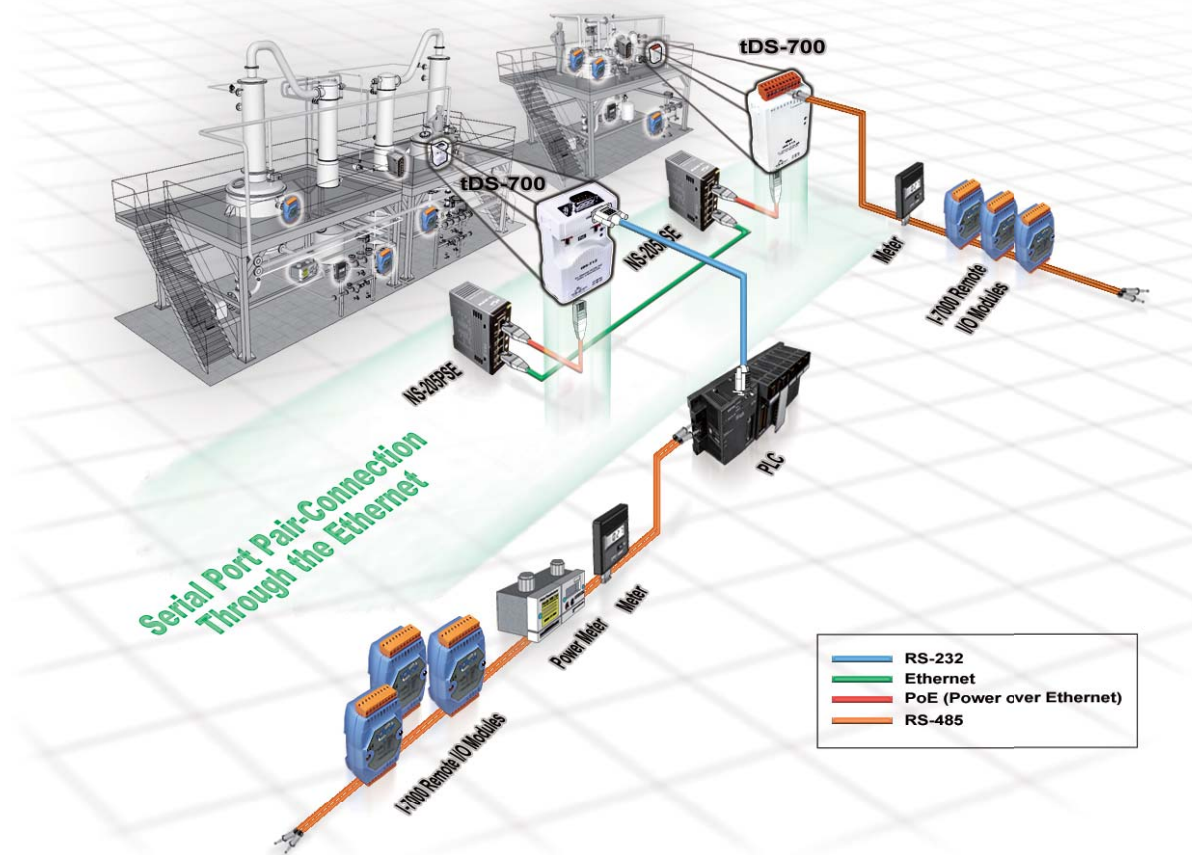

The VxComm Driver/Utility supports the most popular operating system in the world, including 32-bit and 64-bit Windows 7/Vista/2008/2003/XP. The virtual COM works transparently and is protocol independent, enabling perfect integration with your current central computer. The utility provides an easy configuration interface that can be used to quickly create and map virtual COM ports to one or several tDS-700 modules. In addition, the utility contains a built-in terminal program, so users can send/receive command/data via the terminal program for easy testing.

The tDS-700 device servers can be used to create a pair-connection application (as well as serial-bridge or serial-tunnel), and can then route data over TCP/IP between two serial devices, which is useful when connecting mainframe computers, servers or other serial devices that do not themselves have Ethernet capability. By virtue of its protocol independence and flexibility, the tDS-700 meets the demands of virtually any network-enabled application.

DHCP minimizes configuration errors caused by manual IP address configuration, such as address conflicts caused by the assignment of an IP address to more than one computer or device at the same time. The tDS-700 supports the DHCP client function, which allows the tDS-700 to easily obtain the necessary TCP/IP configuration information from a DHCP server. The tDS-700 also contains a UDP responder that transmits its IP address information in response to a UDP search from the VxComm Utility, making local management more efficient.

The tDS-700 features a powerful 32-bit MCU to enable efficient handling of network traffic. It also has a built-in web server that provides an intuitive web management interface to allow users to modify the settings of the module, including DHCP/Static IP, gateway/mask and serial ports.

Based on an amazing tiny form-factor, the tDS-700 achieves the maximum space savings that allows it to be easily installed anywhere, even directly attached to a serial device or embedded into a machine.

The tDS-700 series also contains a built-in CPU watchdog, which automatically resets the CPU if the built-in firmware is operating abnormally, or if there is no communication between the tDS-700 and the host for a predefined period of time (system timeout). This is an important feature that ensures the tDS-700 operates continuously, even in harsh environments.



The tDS-700 offers true IEEE 802.3af-compliant (classification, Class 1) Power over Ethernet (PoE) functionality using a standard category 5 Ethernet cable to receive power from a PoE switch such as the NS-205PSE. If there is no PoE switch on site, the tDS-700 will also accept power input from a DC adapter. The tDS-700 is designed for ultra-low power consumption, reducing hidden costs from increasing fuel and electricity prices, especially when you have a huge amount of device servers installed. Reducing the amount of electricity consumed by choosing energy-efficient equipment can have a positive impact on maintaining a green environment.

The tDS-712 is equipped with a male DB-9 connector, while other models are equipped with a removable terminal block connector to allow easy wiring, and also supports automatic RS-485 direction control when sending and receiving data.

The tDS-700 has the same basic Serial-to-Ethernet gateway and virtual COM functions as the PPDS-700-MTCP series, as shown in the right-hand-side comparison table.

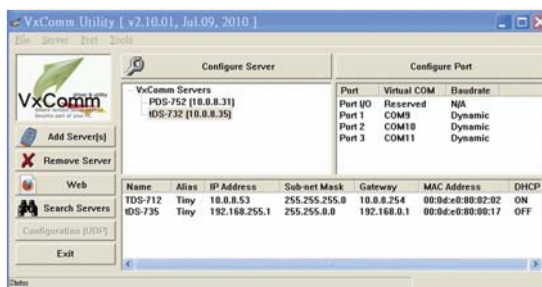

Comparison Table	tDS-700 Series	PPDS-700-MTCP Series
Ethernet	10/100 M, PoE	10/100 M, PoE
Programmable	-	Yes
Virtual COM	Yes	Yes
Virtual I/O	-	Yes
DHCP	Yes	Yes
Web Configuration	Yes	Yes
UDP Search	Yes	Yes
Modbus Gateway	-	Yes
Multi-client	-	Yes
Remarks	Cost-effective	-

Applications

- Factory Automation
- Home Automation
- Building Automation
- Remote Diagnosis and Management



3
7
Serial Device Server

1. Access serial device via Virtual COM ports

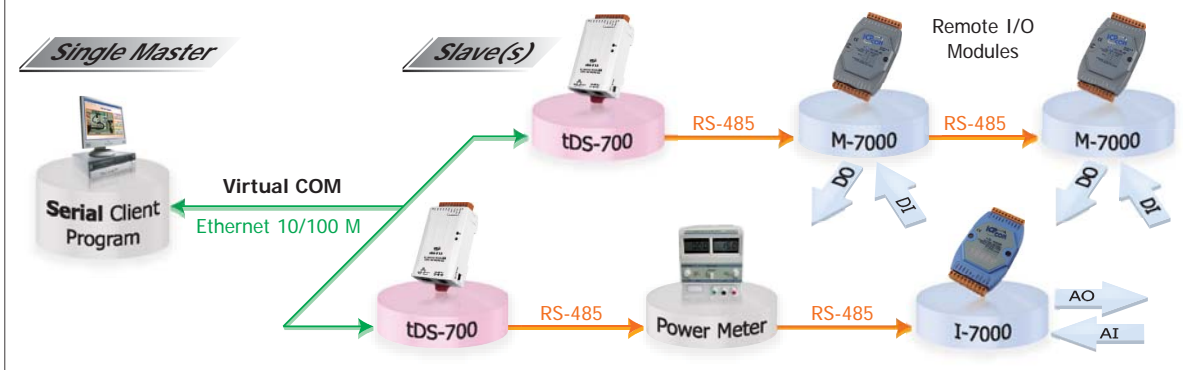

2. Access serial device via TCP/IP socket connection

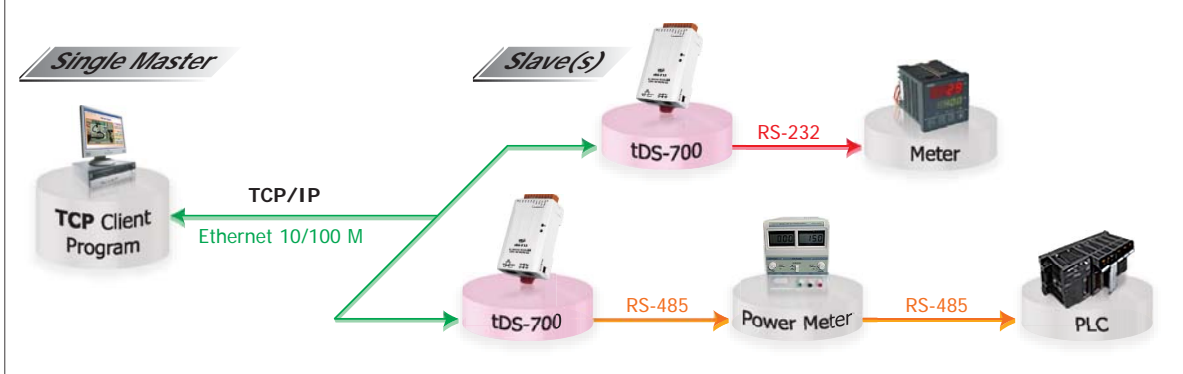

3. Serial converter application through pair-connection

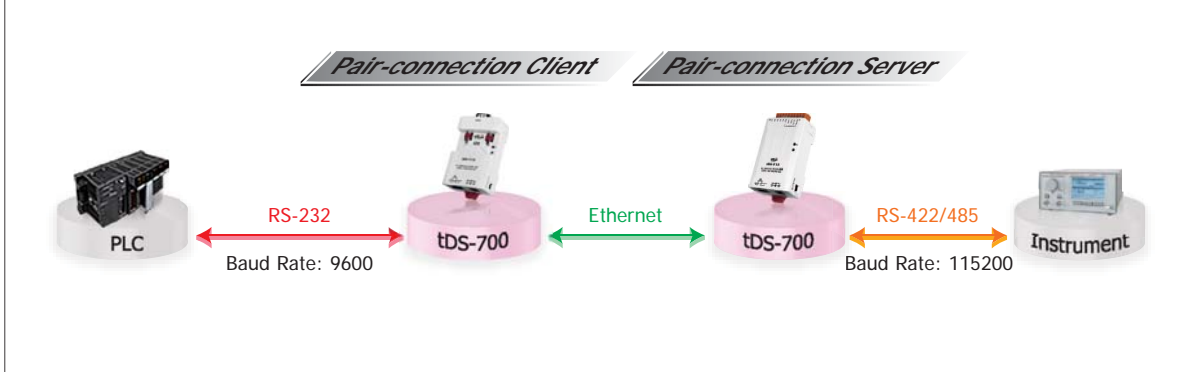

4. Virtual RS-485 bus application through pair-connection

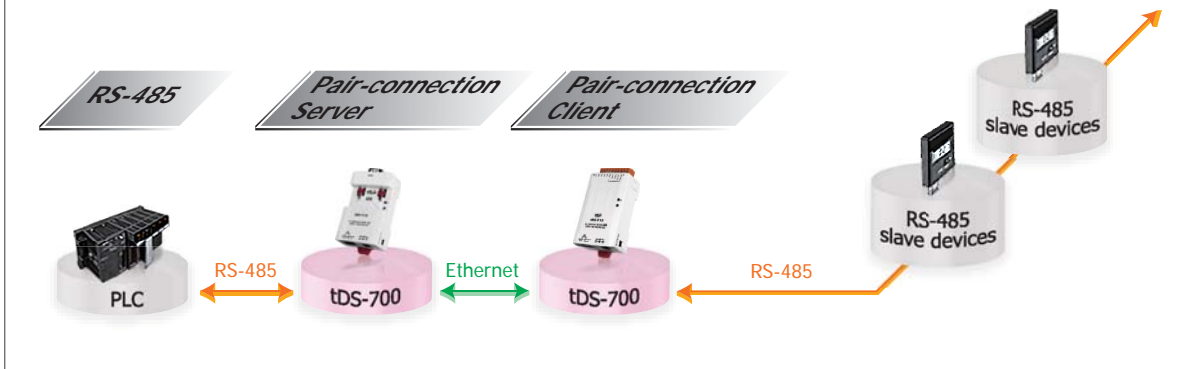

3

7

Serial Device Server

tGW-700 Series *NEW*

Tiny Modbus/TCP to RTU/ASCII Gateway



tGW-712

tGW-700 series



Features ▶▶▶

- Incorporates any RS-232/422/485 serial device in Ethernet
- Supports Modbus TCP to RTU/ASCII Gateway
- Supports Modbus RTU/ASCII to TCP Gateway
- 10/100 Base-TX Ethernet, RJ-45 x1 (Auto-negotiating, auto MDI/MDIX, LED Indicators)
- Includes redundant power inputs: PoE and DC jack
- Allows easy firmware updates via the Ethernet
- Male DB-9 or terminal block connector for easy wiring
- RoHS Compliant & no Halogen
- Cost-effective Device Servers
- 32-bit MCU that efficiently handles network traffic
- Supports pair-connection (serial-bridge, serial-tunnel) applications
- Supports TCP, UDP, HTTP, DHCP, BOOTP and TFTP protocols
- Supports UDP responder for device discovery
- Allows automatic RS-485 direction control
- Provides an intuitive web configuration interface
- Tiny form-factor and low power consumption
- Made from fire-retardant materials (UL94-V0 Level)

Introduction

Modbus has become a de facto standard industrial communication protocol, and is now the most commonly available means of connecting industrial electronic devices. Modbus allows for communication between many devices connected to the same RS-485 network, for example, a system that measures temperature and humidity and communicates the results to a computer. Modbus is often used to connect a supervisory computer with a remote terminal unit (RTU) in supervisory control and data acquisition (SCADA) systems.

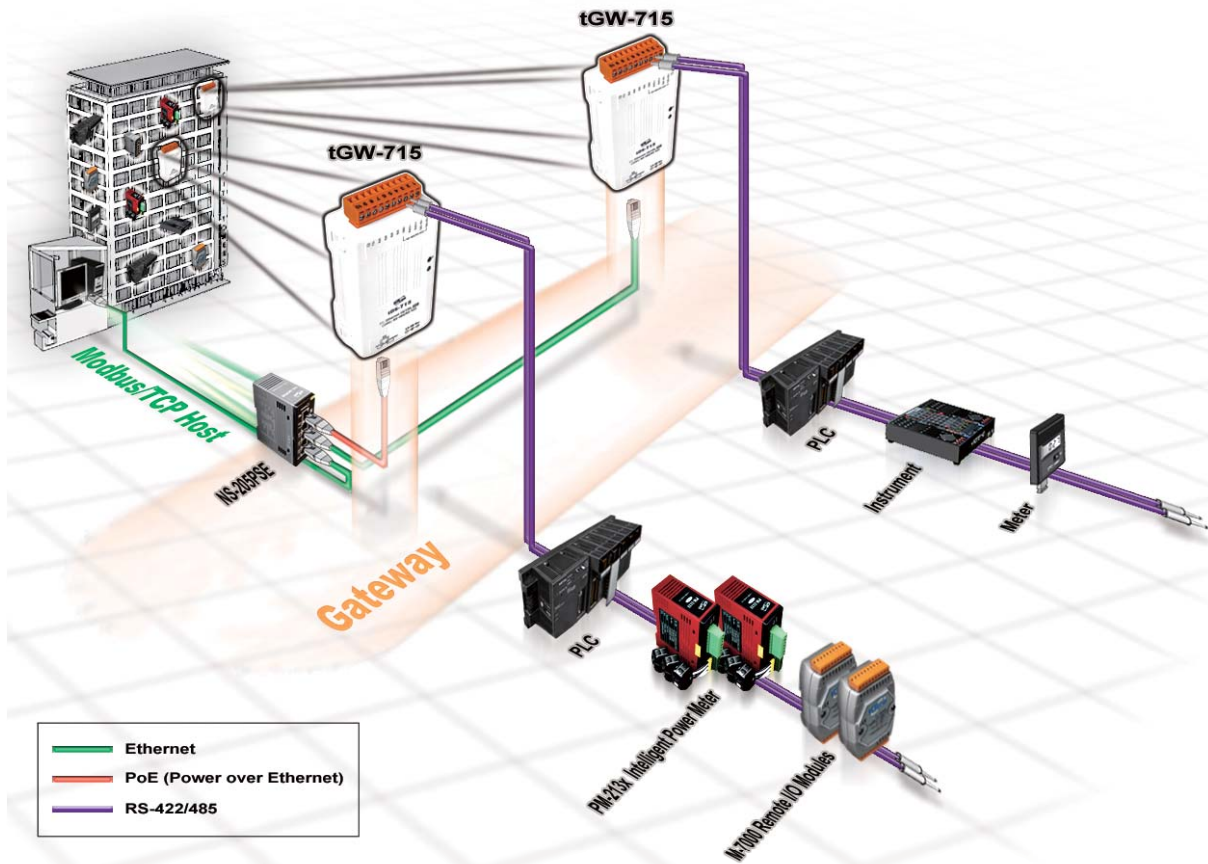

The tGW-700 module is a Modbus TCP to RTU/ASCII gateway that enables a Modbus/TCP host to communicate with serial Modbus RTU/ASCII devices through an Ethernet network, and eliminates the cable length limitation of legacy serial communication devices. The module can be used to create a pair-connection application (as well as serial-bridge or serial-tunnel application), and can then route data over TCP/IP between two serial Modbus RTU/ASCII devices, which is useful when connecting mainframe computers, servers or other serial devices that use Modbus RTU/ASCII protocols and do not themselves have Ethernet capability.

DHCP minimizes configuration errors caused by manual IP address configuration, such as address conflicts caused by the assignment of an IP address to more than one computer or device at the same time. The tGW-700 module supports the DHCP client function, which allows it to easily obtain the necessary TCP/IP configuration information from a DHCP server. The module also contains a UDP responder that transmits its IP address information in response to a UDP search from the eSearch utility, making local management more efficient.

The tGW-700 module features a powerful 32-bit MCU to enable efficient handling of network traffic, and also has a built-in web server that provides an intuitive web management interface that allows users to modify the configuration of the module, including the DHCP/Static IP, the gateway/mask settings and the serial port settings.

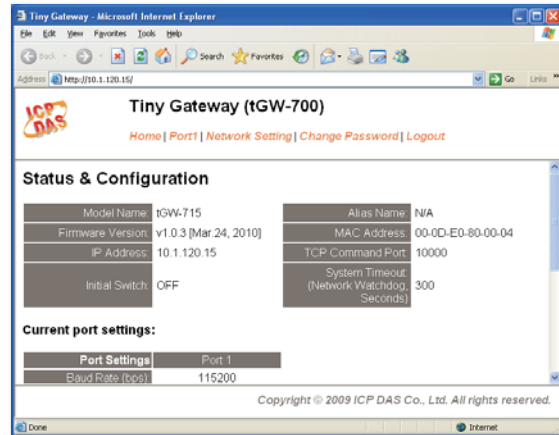

The module contains a dual watchdog, including a CPU watchdog (for hardware functions) and a host watchdog (for software functions). The CPU watchdog automatically resets the CPU if the built-in firmware is operating abnormally, while the host watchdog automatically resets the CPU if there is no communication between the module and the host (PC or PLC) for a predefined period of time (system timeout). The dual watchdog is an important feature that ensures the module operates continuously, even in harsh environments.



The tGW-700 module offers true IEEE 802.3af-compliant (classification, Class 1) Power over Ethernet (PoE) functionality using a standard category 5 Ethernet cable to receive power from a PoE switch such as the NS-205PSE. If there is no PoE switch on site, the module will also accept power input from a DC adapter. The tGW-700 module is designed for ultra-low power consumption, reducing hidden costs from increasing fuel and electricity prices, especially when you have a large number of modules installed. Reducing the amount of electricity consumed by choosing energyefficient equipment can have a positive impact on maintaining a green environment.

The module is equipped with a male DB-9 or a removable terminal block connector to allow easy wiring. Based on an amazing tiny form-factor, the tGW-700 achieves maximum space savings that allows it to be easily installed anywhere, even directly embedded into a machine. It also supports automatic RS-485 direction control when sending and receiving data, thereby improving the stability of the RS-485 communication.

Comparison Table	Ethernet	Programmable	Virtual COM	Virtual I/O	DHCP	Web Configuration	UDP Search	Modbus Gateway	Multi-client
tGW-700 Series	10/100 M, PoE	-	-	-	Yes	Yes	Yes	Yes	-
PPDS-700-MTCP Series	10/100 M, PoE	Yes	Yes	Yes	Yes	Yes	Yes	Yes	Yes

Applications

- Factory Automation
- Home Automation
- Building Automation
- Remote Diagnosis and Management

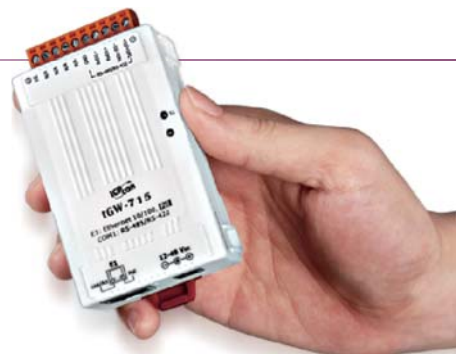

1. Modbus TCP to RTU/ASCII Gateway application

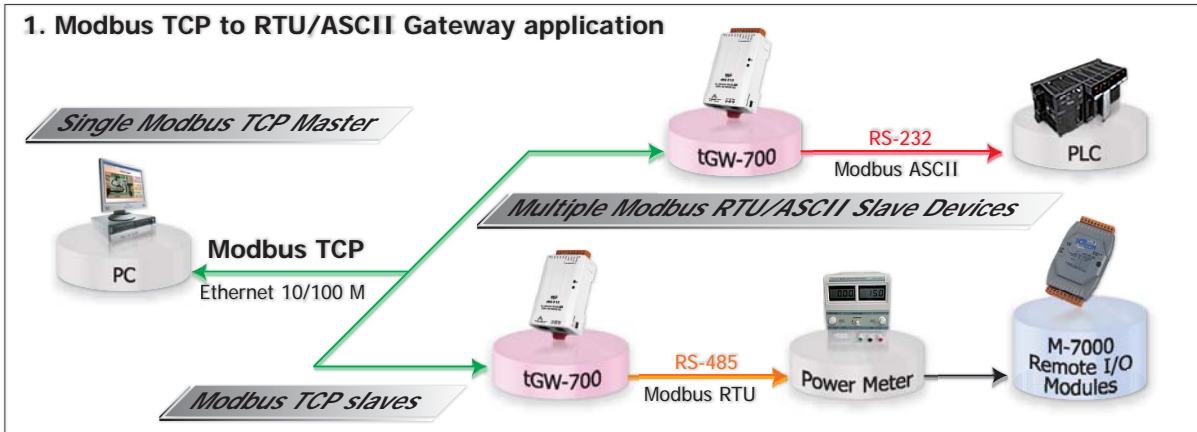

2. Modbus TCP to RTU/ASCII Gateway application (dual-port)

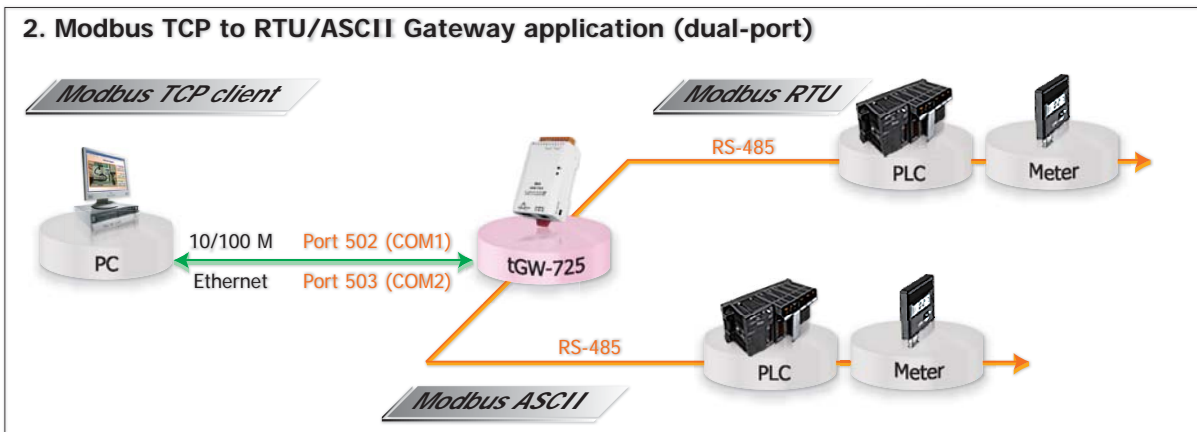

3. Modbus RTU/ASCII to TCP Gateway application (like pair-connection)

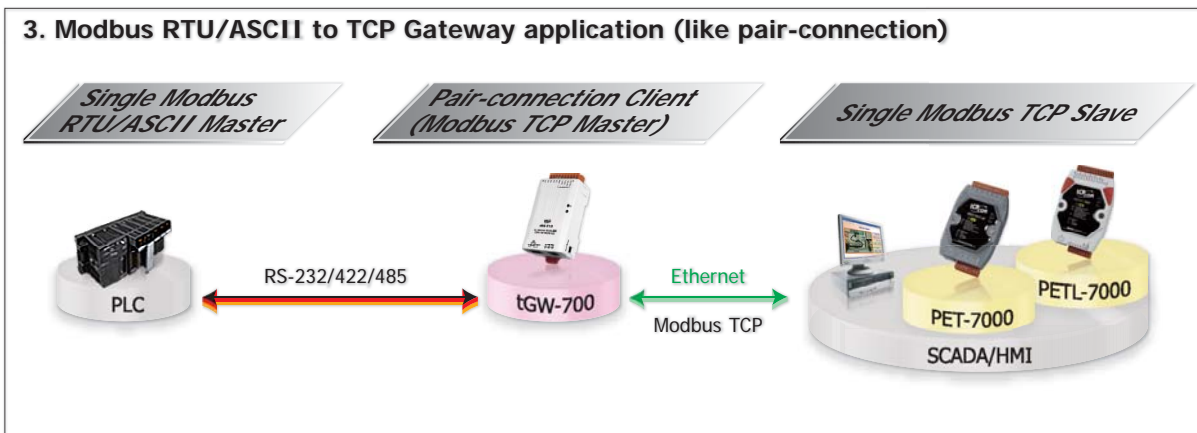

4. Virtual RS-485 bus application through pair-connection

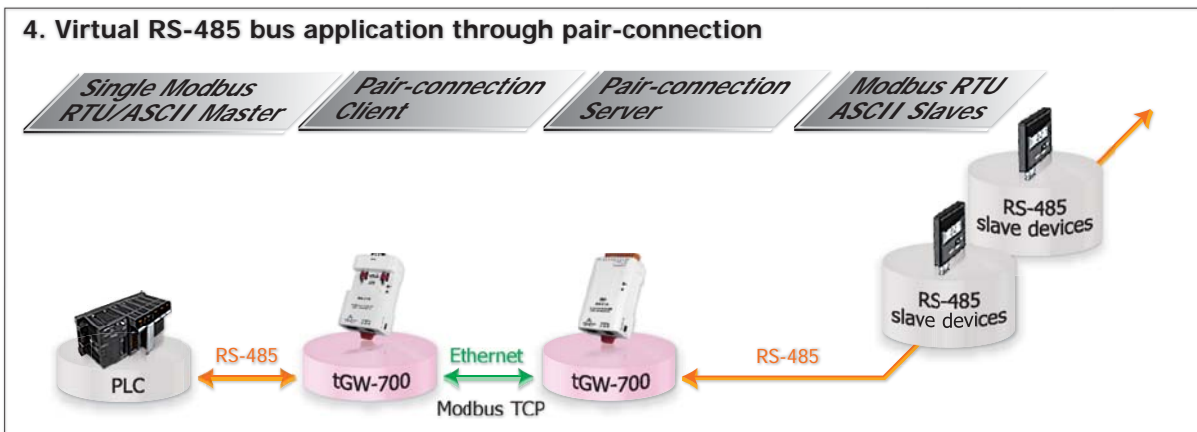

3
7
Serial Device Server

System Specifications

Models	tDS-712 tGW-712	tDS-722 tGW-722	tDS-732 tGW-732	tDS-715 tGW-715	tDS-725 tGW-725	tDS-735 tGW-735	tDS-718 tGW-718	tDS-724 tGW-724	tDS-734 tGW-734
System									
CPU	32-bit MCU								
Communication Interface									
Ethernet	10/100 Base-TX, 8-pin RJ-45 x 1, (Auto-negotiating, Auto-MDI/MDIX, LED indicator) PoE (IEEE 802.3af, Class 1)								
COM1	5-wire RS-232	5-wire RS-232	3-wire RS-232	2-wire RS-485	2-wire RS-485	2-wire RS-485	3-wire RS-232	2-wire RS-485	2-wire RS-485
				4-wire RS-422			4-wire RS-422		
COM2	-	5-wire RS-232	3-wire RS-232	-	2-wire RS-485	2-wire RS-485	-	5-wire RS-232	3-wire RS-232
COM3	-	-	3-wire RS-232	-	-	2-wire RS-485	-	-	3-wire RS-232
Self-Tuner	- Yes, automatic RS-485 direction control								
UART	16C550 or compatible								
COM Port Format									
Baud Rate	115200 bps Max.								
Data Bit	5, 6, 7, 8								
Parity	None, Odd, Even, Mark, Space								
Stop Bit	1, 2								
Power									
Power Input	PoE	IEEE 802.3af, Class 1							
	DC Jack	+12 ~ 48 Vdc							
Power Consumption	0.05 A @ 24 Vdc								
Connector	Male DB-9 x 1		10-Pin Removable Terminal Block x 1						
Mechanical									
Flammability	Fire-Retardant Materials (UL94-V0 Level)								
Dimensions (W x H x D)	52 mm x 90 mm x 27 mm			52 mm x 95 mm x 27 mm					
Installation	DIN-Rail mounting								
Environment									
Operating Temperature	-25 °C ~ +75 °C								
Storage Temperature	-30 °C ~ +80 °C								
Humidity	10 ~ 90% RH, non-condensing								
3-wire RS-232: RxD, TxD, GND (Non-isolated)									
5-wire RS-232: RxD, TxD, CTS, RTS, GND (Non-isolated)									
2-wire RS-485: DATA+, DATA-, GND (Non-isolated)									
4-wire RS-422: TxD+, TxD-, RxD+, RxD-, GND (Non-isolated)									

Pin Assignments

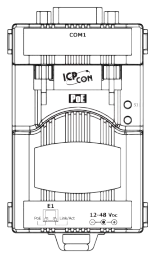

tDS-712/tGW-712	
09	N/A
08	CTS1
07	RTS1
06	N/A
05	GND
04	N/A
03	TxD1
02	RxD1
01	N/A

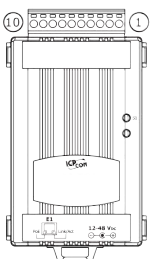

tDS-722/tGW-722	
10	F.G.
09	CTS2
08	RTS2
07	RxD2
06	TxD2
05	GND
04	CTS1
03	RTS1
02	RxD1
01	TxD1

tDS-732/tGW-732	
10	F.G.
09	GND
08	RxD3
07	TxD3
06	GND
05	RxD2
04	TxD2
03	GND
02	RxD1
01	TxD1

tDS-735/tGW-735	
10	F.G.
09	GND
08	D3-
07	D3+
06	GND
05	D2-
04	D2+
03	GND
02	D1-
01	D1+

tDS-718/tGW-718	
10	F.G.
09	N/A
08	GND
07	RxD1
06	TxD1
05	GND
04	RxD1-
03	RxD1+
02	TxD1-/D1-
01	TxD1+/D1+

tDS-715/tGW-715	
10	F.G.
09	N/A
08	N/A
07	N/A
06	N/A
05	GND
04	RxD1-
03	RxD1+
02	TxD1-/D1-
01	TxD1+/D1+

tDS-725/tGW-725	
10	F.G.
09	N/A
08	N/A
07	N/A
06	GND
05	D2-
04	D2+
03	GND
02	D1-
01	D1+

tDS-724/tGW-724	
10	F.G.
09	N/A
08	CTS2
07	RTS2
06	GND
05	RxD2
04	TxD2
03	GND
02	D1-
01	D1+

tDS-734/tGW-734	
10	F.G.
09	GND
08	RxD3
07	TxD3
06	GND
05	RxD2
04	TxD2
03	GND
02	D1-
01	D1+

Dimensions (Unit: mm)

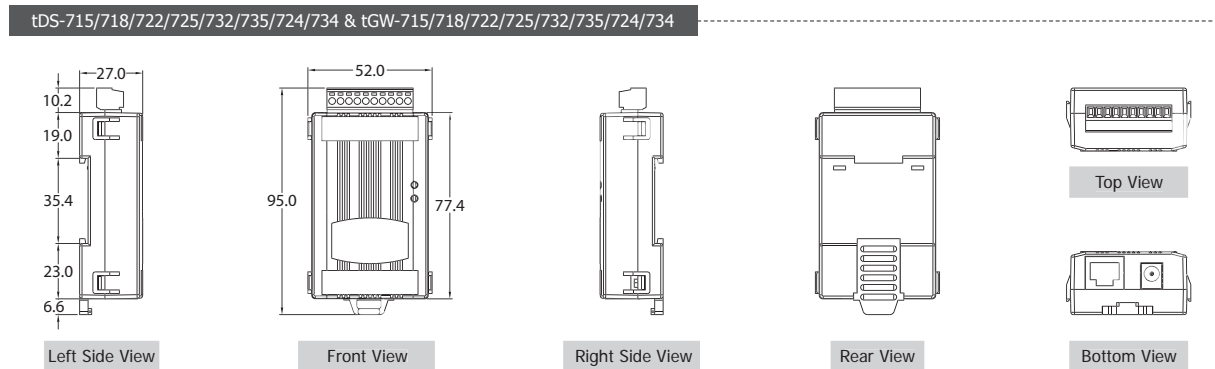
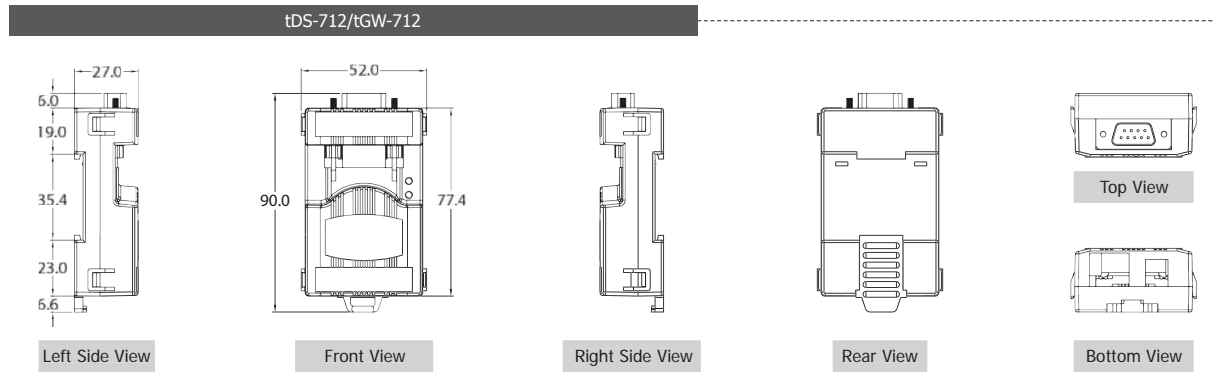

Ordering Information

tDS-700 Series	
tDS-712 CR	Tiny Device Server with PoE and 1 RS-232 Port (RoHS)
tDS-722 CR	Tiny Device Server with PoE and 2 RS-232 Ports (RoHS)
tDS-732 CR	Tiny Device Server with PoE and 3 RS-232 Ports (RoHS)
tDS-715 CR	Tiny Device Server with PoE and 1 RS-422/485 Port (RoHS)
tDS-725 CR	Tiny Device Server with PoE and 2 RS-485 Ports (RoHS)
tDS-735 CR	Tiny Device Server with PoE and 3 RS-485 Ports (RoHS)
tDS-718 CR	Tiny Device Server with PoE and 1 RS-232/422/485 Port (RoHS)
tDS-724 CR	Tiny Device Server with PoE, 1 RS-485 and 1 RS-232 Ports (RoHS)
tDS-734 CR	Tiny Device Server with PoE, 1 RS-485 and 2 RS-232 Ports (RoHS)
Includes: One CA-002 cable.	
tGW-700 Series	
tGW-712 CR	Tiny Modbus/TCP to RTU/ASCII Gateway with PoE and 1 RS-232 Port (RoHS)
tGW-722 CR	Tiny Modbus/TCP to RTU/ASCII Gateway with PoE and 2 RS-232 Ports (RoHS)
tGW-732 CR	Tiny Modbus/TCP to RTU/ASCII Gateway with PoE and 3 RS-232 Ports (RoHS)
tGW-715 CR	Tiny Modbus/TCP to RTU/ASCII Gateway with PoE and 1 RS-422/485 (RoHS)
tGW-725 CR	Tiny Modbus/TCP to RTU/ASCII Gateway with PoE and 2 RS-485 Ports (RoHS)
tGW-735 CR	Tiny Modbus/TCP to RTU/ASCII Gateway with PoE and 3 RS-485 Ports (RoHS)
tGW-718 CR	Tiny Modbus/TCP to RTU/ASCII Gateway with PoE and 1 RS-232/422/485 Port (RoHS)
tGW-724 CR	Tiny Modbus/TCP to RTU/ASCII Gateway with PoE, 1 RS-485 and 1 RS-232 Ports (RoHS)
tGW-734 CR	Tiny Modbus/TCP to RTU/ASCII Gateway with PoE, 1 RS-485 and 2 RS-232 Ports (RoHS)
Includes: One CA-002 cable.	

Accessories

CA-002	DC connector to 2-wire power cable, 0.3 M
CA-0915	Male DB-9 to Female DB-9 Cable, 1.5 m
CA-0910F	Female DB-9 to Female DB-9 Cable, 1.0 m
CA-0910N	DB-9 Female-Female 3-wire Null Modem Cable, 1M
CA-PC09F	DB-9 Female Connector with Plastic Cover
FRA05-S12-SU CR	12V/0.58A (max.) Power Supply (RoHS, for tDS/tGW-700)
DIN-KA52F CR	24V/1.04A, 25 W Power Supply with DIN-Rail Mounting (RoHS, for NS-205 and NS-205PSE-24V)
DIN-KA52F-48 CR	48V/0.52A, 25 W Power Supply with DIN-Rail Mounting (RoHS, for NS-205PSE)
NS-205 CR	Unmanaged 5-port Industrial Ethernet Switch (RoHS)
NS-205PSE CR	Unmanaged Ethernet Switch with 4 PoE Ports and 1 RJ-45 Uplink (RoHS)
NS-205PSE-24V CR	Unmanaged 5-port 10/100 Mbps PoE (PSE) Ethernet Switch; 24 Vdc Input (RoHS)

3-8 Programmable Serial Device Server with LAN Switch

PDS-5105D-MTCP NEW

Programmable Device Server with 10 RS-485 Ports,
2-port LAN Switch and LED Display



Features ▶▶▶

- Integrates any RS-485 serial device in an Ethernet Network
- Virtual COM extends the PC COM ports
- Virtual COM supports 32-bit and 64-bit Windows XP/2003/Vista/7
- Provides 10 RS-485 ports with Self-Tuner (Auto-direction control)
- +/- 2 kV ESD protection on serial ports
- RoHS compliant & no halogen
- 2-port 10/100 Base-TX Ethernet Switch with LAN Bypass
- Powerful programmable device server
- Watchdog timer suitable for use in harsh environments
- Power reverse polarity protection
- Built-in high performance MiniOS7 from ICP DAS
- ODM service is available
- Made from fire-retardant materials (UL94-V0 level)
- Low power consumption

Introduction

The PDS-5105D-MTCP is a Programmable Device Server, also known as a "Serial-to-Ethernet gateway" that is designed to allow Ethernet connectivity to be added to RS-232/485 devices.

The user-friendly VxComm Driver/Utility allows users to easily turn the built-in COM ports of the PDS-5105D-MTCP series into standard COM ports on a PC. By virtue of its protocol independence, specialized OS and high flexibility, the PDS-5105D-MTCP series is able to meet the demands of any network-enabled application.

The PDS-5105D-MTCP series includes a powerful and reliable Xserver programming structure that allows you to quickly develop custom robust Ethernet applications. The built-in, high-performance MiniOS7 boots the PDS-5105D-MTCP up in just one second and gives you the fastest response.

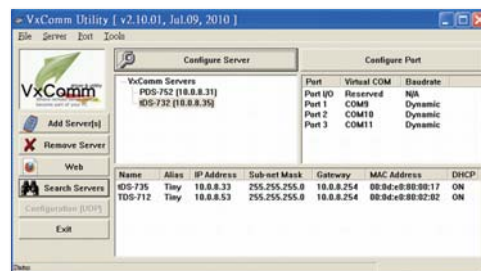

2-port Ethernet Switch with LAN Bypass

The PDS-5105D-MTCP is equipped with a 2-port 10/100Base-Tx Ethernet switch that simplifies network wiring by cascading Ethernet devices. Furthermore, the module features a LAN Bypass function allowing network traffic to be continued between two network segments (Ethernet port1 and port2). In cases where the module is offline due to software, hardware or power failure, the LAN Bypass function will be automatically activated, and the essential communications on the network can continue operating without interruption.

LAN Bypass Feature

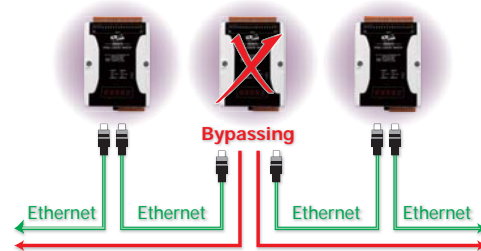

System Specifications

System	
CPU	80186 or compatible (16-bit and 80 MHz)
SRAM	512 KB
Flash Memory	512 KB; Erase unit is one sector (64 KB); 100,000 erase/write cycles
EEPROM	16 KB
Watchdog Timers	Yes (0.8 seconds)
Communication Ports	
Ethernet	2-port 10/100 Base-TX Ethernet Switch with LAN Bypass, RJ-45 x 2 (Auto-negotiating, Auto-MDI/MDIX, LED indicator)
COM1	RS-232 (TxD, RxD, GND)/RS-485 (D1+, D1-), Self-Tuner ASIC inside, non-isolated
COM2 ~ 10	RS-485 (Dx+, Dx-), Self-Tuner ASIC inside, non-isolated

COM Port Formats	
Baud Rate	115200 bps Max. @ 10 Ports, half-duplex, 80% loading
Data Bit	7, 8: for COM1 and COM2 5, 6, 7, 8: for COM3 ~ COM10
Parity	None, Odd, Even, Mark, Space
Stop Bit	1, 2: for COM1 ~ COM10
LED Indicators	
5-Digit 7 Segment	Yes
System	Red
Power	
Protection	Power Reverse Polarity Protection
Frame GND	Yes (for EMS Protection)
Input Range	+12 ~+48 Vdc (non-regulated)
Power Consumption	4.8 W
Mechanical	
Flammability	Fire-Retardant Materials (UL94-V0 Level)
Dimension (W x H x D)	91 mm x 123 mm x 52 mm
Installation	DIN-Rail mounting
Environment	
Operating Temperature	-25 °C ~ +75 °C
Storage Temperature	-30 °C ~ +85 °C
Humidity	5 ~ 95% RH, non-condensing

Applications

- Factory Automation
- Building Automation
- Home Automation

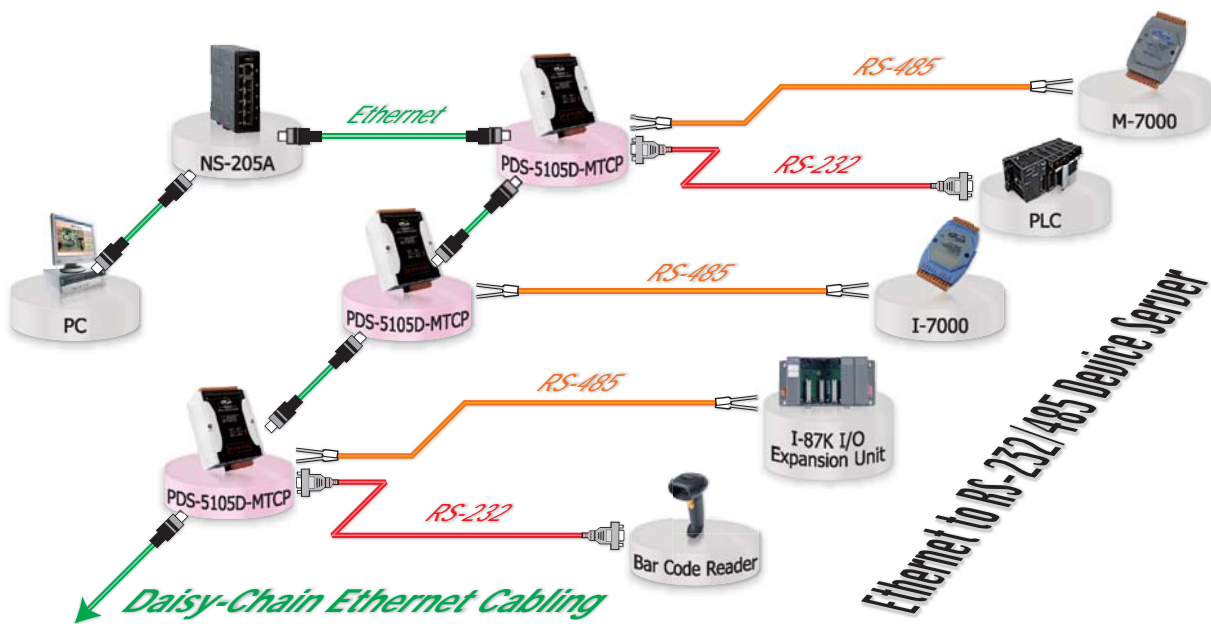

Ordering Information

PDS-5105D-MTCP CR	Programmable Device Server with 10 RS-485 Ports, 2-port LAN Switch and LED Display. (RoHS)
-------------------	--

Accessories

GPSU06U-6	24 Vdc/0.25 A, 6 W Power Supply
MDR-20-24	24 Vdc/1 A, 24 W Power Supply with DIN-Rail Mounting
CA-0903	9-Pin Female D-sub and RS-232 connector cable, 30 cm Cable
CA-0910	9-Pin Female D-sub and 3-wire RS-232 cable, 1 M Cable
NS-205 CR	Unmanaged 5-port Industrial Ethernet Switch (RoHS)
DIN-KA52F-48	48 Vdc/0.52 A, 25 W Power Supply with DIN-Rail Mounting

3-9 Programmable Modbus to Ethernet Gateway

μPAC-7186EX(D)-MTCP *NEW*

Modbus/RTU to Modbus/TCP Gateway



μPAC-7186EX-MTCP

μPAC-7186EXD-MTCP



Features ▶▶▶▶

- Incorporate Serial Devices in an Ethernet network
- "Virtual COM" extends PC COM ports
- 10/100 Base-TX (Auto-negotiating, auto MDI/MDI-X, LED indicator)
- Self-Tuner ASIC Controller on the RS-485 Port
- 5-digit LED Display (for versions with a display)
- Built-in High Performance MiniOS7 from ICP DAS
- Made from fire-retardant materials (UL94-V0 Level)
- Supports Modbus/TCP and Modbus/RTU
- Virtual COM for 32-bit and 64-bit Windows XP/2003/Vista/7
- Programmable Internet/Ethernet Controller
- Watchdog Timer suitable for use in harsh environments
- Power Reverse Polarity Protection Circuit
- RS-485 Port ESD Protection Circuit
- RoHS Compliant & no Halogen
- Low power consumption

Introduction

The Modbus communications protocol has become the de facto industry standard, and is now the most commonly available means of connecting industrial electronic devices.

Modbus allows for communication between many devices connected to the same network, for example a system that measures temperature and humidity and communicates the results to a computer. Modbus is often used to connect a supervisory computer with a remote terminal unit (RTU) in supervisory control and data acquisition (SCADA) systems.

The μPAC-7186EX(D)-MTCP uses a default firmware to become a single Modbus/TCP to multiple Modbus/RTU converter. You can simply use the Modbus Utility to configure the device and then set the connection between the SCADA or HMI software and the μPAC-7186EX(D)-MTCP.

The μPAC-7186EX(D)-MTCP can also link to legacy serial devices that don't support Modbus/RTU. To use this function, you need to install the VxComm driver on the host PCs and create virtual COM ports for the remote serial ports on the μPAC-7186EX(D)-MTCP. You can then directly access the remote serial devices via the virtual COM ports.

Using the Modbus SDK, users can develop their own custom Modbus firmware, allowing extra functions and integration of serial devices. In this way, the μPAC-7186EX(D)-MTCP becomes a powerful controller.

The μPAC-7186EX(D)-MTCP contains a built-in operating system, the MiniOS7, which offers a stable and high performance environment that is similar to DOS. The MiniOS7 can boot up the μPAC-7186EX(D)-MTCP within just one second, with the added benefit of no virus problems and a small footprint. Furthermore, the μPAC-7186EX(D)-MTCP is designed for low power consumption, maintenance elimination (no hard disk and no fan), and is constructed from fire-retardant materials (UL94-V0 level) with a robust case.

I/O Expansion Bus and Expansion Board

The μPAC-7186EX(D)-MTCP supports a single I/O expansion bus for plugging with a X-board. ICP DAS provides many optional X-boards for the μPAC-7186EX(D)-MTCP, which offers various I/O functions, such as D/I, D/O, A/D, D/A, Timer/Counter, UART, flash memory, battery backup SRAM and AsicKey... etc.

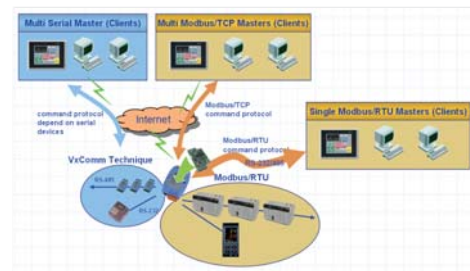
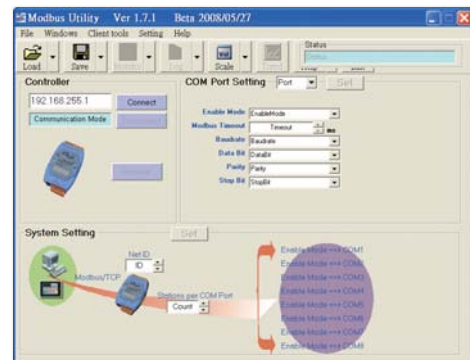

Applications

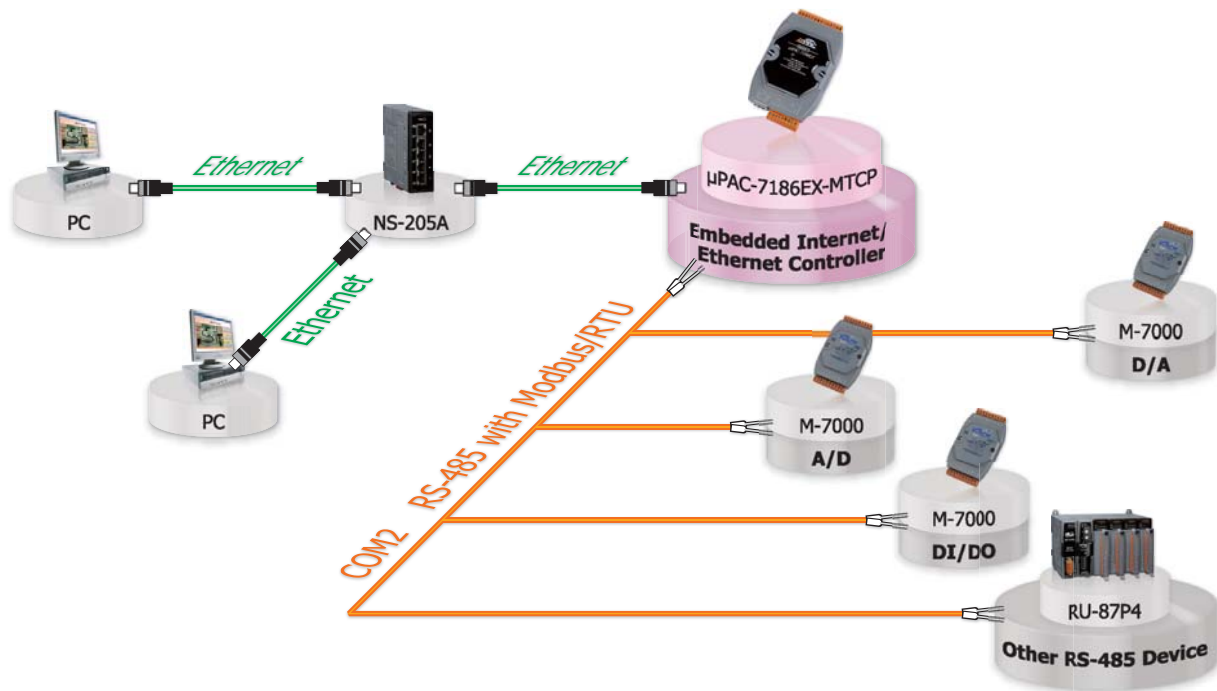

System Specifications

Models	μ PAC-7186EX-MTCP	μ PAC-7186EXD-MTCP
CPU		
CPU	80186, 80 MHz or compatible	
SRAM	512 KB	
Flash Memory	512 KB	
EEPROM	16 KB	
NVRAM	31 Bytes (battery backup, data valid for up to 10 years)	
RTC (Real Time Clock)	Yes	
Hardware Serial Number	Yes (64-bit)	
Built-in Watchdog Timer	Yes	
Communication Interface		
COM1	RS-232 (Tx, Rx, RTS, CTS, GND)	
COM2	RS-485 (D2+, D2-, GND)	
Ethernet	10/100 Base-TX, RJ-45 port (Auto-negotiating, auto MDI/MDI-X, LED indicators)	
COM Port Formats		
Speed	115200 bps max.	
Data Bit	7, 8	
Parity	None, Even, Odd	
Stop Bit	1	
LED Indicators		
5-Digit 7 Segment	–	Yes
System	Yes	
Power		
ESD Protection	Yes (with Frame Ground)	
Protection	Power Reverse Polarity Protection	
Required Supply Voltage	+10 V _{DC} ~ +30 V _{DC} (non-regulated)	
Power Consumption	1.5 W	2.5 W
Mechanical		
Flammability	Fire-Retardant Materials (UL94-V0 Level)	
Dimension (W x H x D)	72 mm x 123 mm x 35 mm	
Installation	DIN-Rail or Wall mounting	
Environment		
Operating Temperature	-25 °C ~ +75 °C	
Storage Temperature	-40 °C ~ +80 °C	
Humidity	5 ~ 95% RH, non-condensing	

Wiring

2-wire RS-485 Wiring

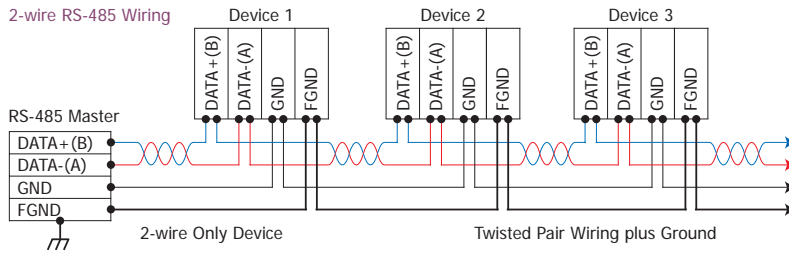

3-wire RS-232 Wiring

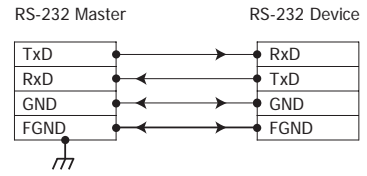

Pin Assignments

μPAC-7186EX(D)-MTCP

Terminal No.	Pin Assignment
E1	Link/Act
	10/100M
COM1	01 CTS1
	02 RTS1
	03 RxD1
	04 TxD1
05	INIT*
COM2	06 D2+
	07 D2-
08	(R)+Vs
09	(B)GND

I/O Expansion Bus

J1			
GND	01	02	GND
CLKOUTA	03	04	ARDY
INTO	05	06	INT1
VCC	07	08	RESET
GND	09	10	RESET\
TO0	11	12	TO1
TIO	13	14	TIO1
SCLK	15	16	DIO9
DIO4	17	18	DIO14
VCC	19	20	VCC

CON20A JDIP20P

J2			
MA0	01	02	AD0
MA1	03	04	AD1
MA2	05	06	AD2
MA3	07	08	AD3
MA4	09	10	AD4
MA5	11	12	AD5
MA6	13	14	AD6
MA7	15	16	AD7
INT4	17	18	WRITE\
CS\	19	20	READ\

CON20A JDIP20P

Dimensions (Unit: mm)

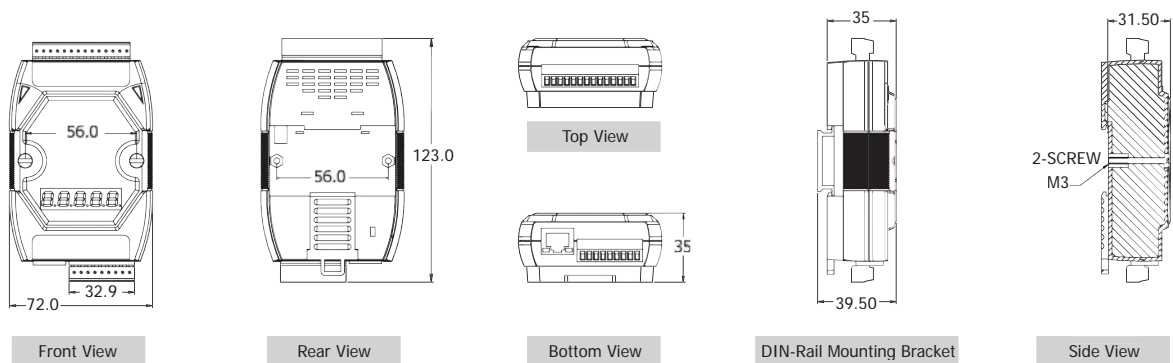

Ordering Information

μPAC-7186EX-MTCP CR	μPAC-7186EX with Default Modbus/TCP Firmware (RoHS)
μPAC-7186EXD-MTCP CR	μPAC-7186EXD with Default Modbus/TCP Firmware (RoHS)

Accessories

GPSU06U-6	24 Vdc/0.25 A, 6 W Power Supply
MDR-20-24	24 Vdc/1 A, 24 W Power Supply with DIN-Rail Mounting
CA-0903	9-Pin Female D-Sub and RS-232 Connector Cable, 30 cm Cable
CA-0910	9-Pin Female D-Sub and 3-wire RS-232 Cable, 1 m Cable
NS-205 CR	Unmanaged 5-port Industrial Ethernet Switch (RoHS)

Converters, Repeaters, Hubs and Splitter



4-1	RS-485 Network Configuration	4-1-1
4-2	RS-422/485 Repeaters	4-2-1
	• RS-485 Repeater	4-2-1
	• RS-422/485 Repeater	4-2-3
4-3	RS-485 Repeater/Hub/Splitter	4-3-1
4-4	RS-232/422/485 Converters	4-4-1
	• RS-232 to RS-485 Converter	4-4-1
	• RS-485 Star Wiring Hub	4-4-3
	• RS-232 to RS-422/485 Converter Card	4-4-5
	• RS-232 to RS-422/485 Converters	4-4-7
	• Isolated RS-232 to RS-232 Converter	4-4-9
4-5	Intelligent Communication Controllers	4-5-1
4-6	USB to RS-232/422/485 Converters	4-6-1
	• USB to RS-232 Converter	4-6-1
	• USB to RS-485 Converter	4-6-5
	• USB to RS-232/422/485 Converters	4-6-7
	• USB to RS-485 Active Star Wiring Converter	4-6-9
4-7	RS-232/422/485 to Fiber Optic Converter	4-7-1

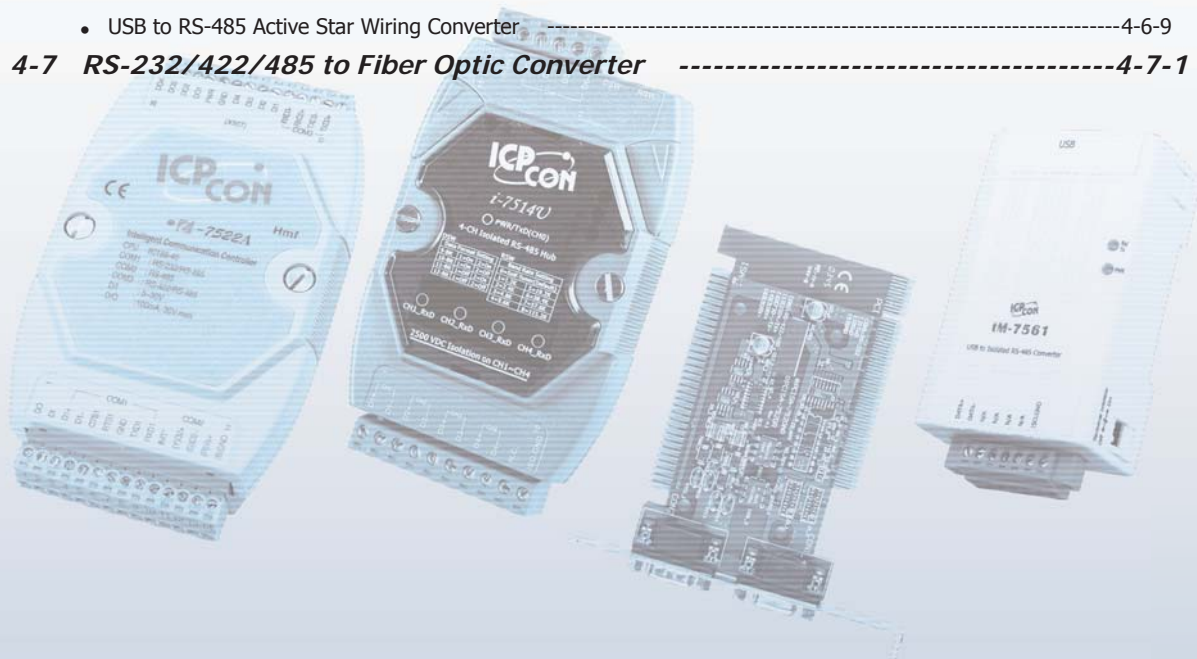

4-1 RS-485 Network Configuration

• ICP DAS Self-Tuner ASIC Features

- Supports Multiple Baud Rate
- Supports Multiple Data Format
- Automatic RS-485 Direction Control

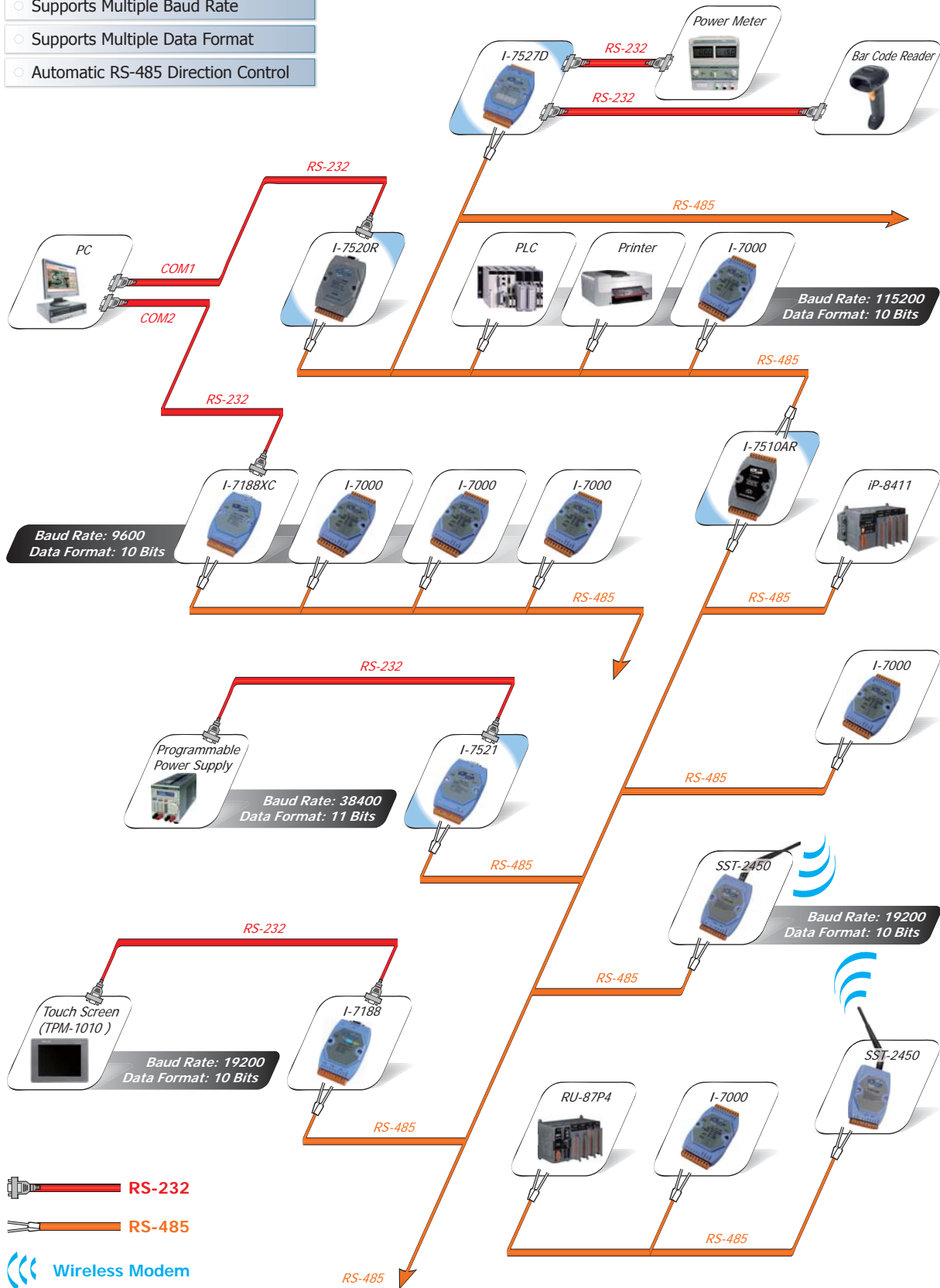

4
1

Converters, Repeaters, Hubs and Splitter

Bus Type

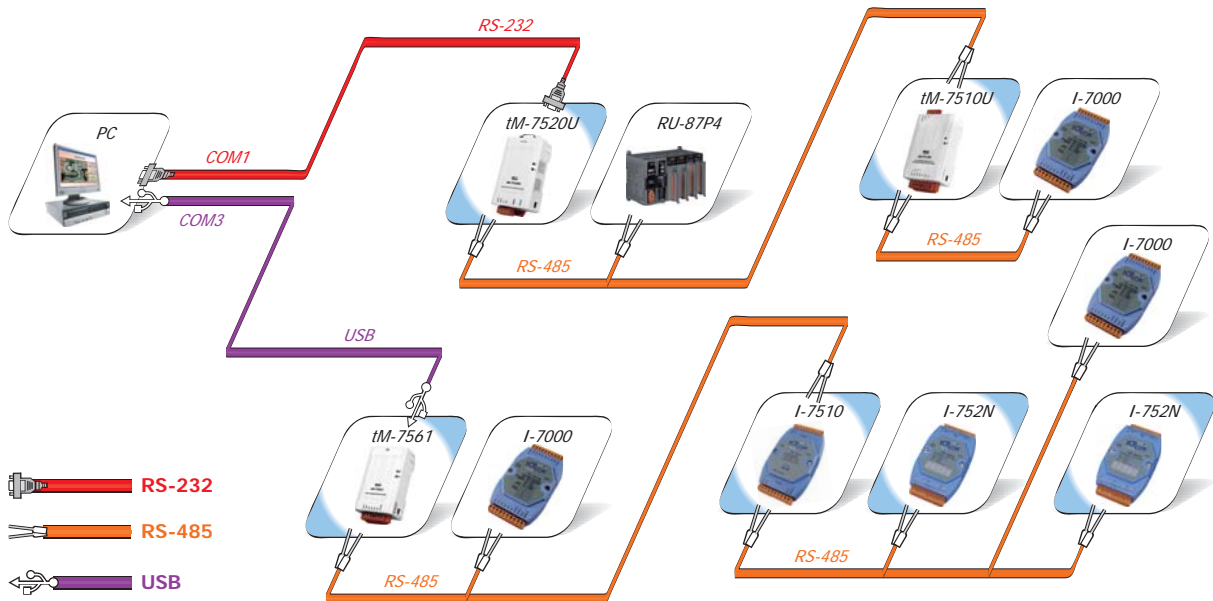

Star Type



High Quality Isolated RS-485 Repeater/Hub/Splitter

The maximum effective distance of RS-485 without repeater is 1200 meters (4000 feet) at baud rates up to 9.6 kbps and up to 32 (256) nodes can be connected. With the professional design, the repeater I-7510 solves the problem of signal weakening and extends the maximum effective distance by 1200 m and connects 32 (256) nodes more. And it has optical isolation design for lightning and surge protection. If the RS-485 topology is too complex to make the communication well, a RS-485 hub or splitter is recommended.

I-7520U4 and I-7514U are multichannel RS-485 repeater/hub/splitter. Each channel is independent and has optical isolation, short circuit and open circuit protection. Thus when one channel fails, it will not affect another channel of the hub. These features make it perfect to star type or mixed type topology in complex and large scale RS-485 network.

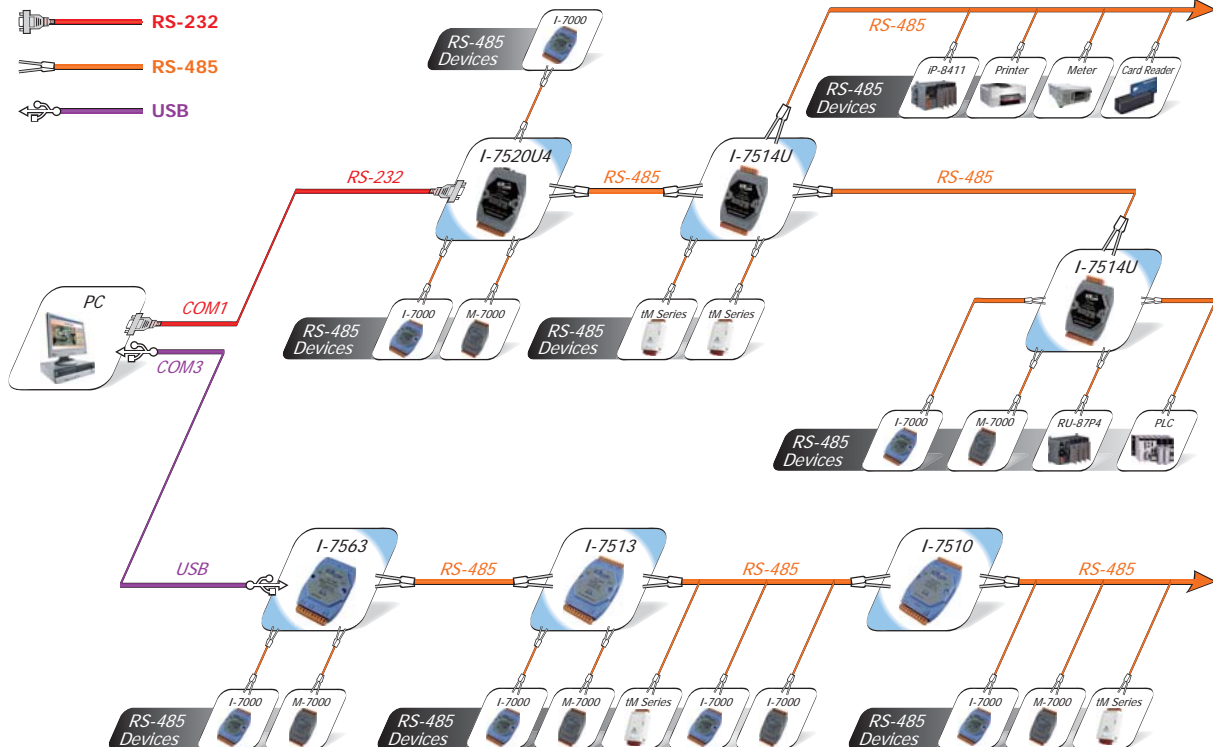

4-2 RS-422/485 Repeaters

tM-7510U **NEW**

Isolated RS-485 Repeater



Features ▶▶▶

- 2-way 2500 V_{DC} Isolation Protection
- ESD Protection for RS-485 Data Line
- Power Input, +10 ~ +30 V_{DC}
- Low power consumption
- Long-cable application
- Power and data flow indicator for troubleshooting
- Easy-to-use rotary switch for baud rate setting, 1200 ~ 115200 bps
- Operating Temperatures, -25 °C ~ +75 °C
- Tiny packaging fits on your DIN-Rail Mounting

4

2

Converters, Repeaters, Hubs and Splitter

Introduction

The tM-7510U repeater simply amplifies, or boosts, existing RS-485 signal to enable them to cover longer distances. It extends the communication distance by 4000 ft. (1200 m) or increases the maximum number of bus nodes. The module provides 2500 V_{DC} of isolation allowing you to separate and protect critical segments of the system from the rest of the RS-485 network.

The tM-7510U provides 2 modes of baud rate setting, one is Self-Tuner mode and the other is Fixed baud rate mode. The Self-Tuner mode can support multiple baud rate and multiple data format. The Self-Tuner design is exactly the same as I-7510 series. The Fixed baud rate mode offers a better quality for data transmission over long or lossy lines or electrically noisy environments.

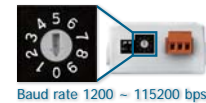

Baud rate 1200 ~ 115200 bps

Comparison Table of Repeater

Mode name	tM-7510U	I-7510
RS-485 Direction Control	Fixed baud rate setting and Automatic RS-485 Direction Control (Self-Tuner, default)	Automatic RS-485 Direction Control (Self-Tuner)
Baud rate	300 ~ 115200 bps for Self-Tuner 1200 ~ 115200 bps for Fixed baud rate setting	300 ~ 115200 bps
Dimensions (W x H x D)	52 mm x 95 mm x 27 mm	72 mm x 122 mm x 35 mm
Remarks	Entry-level Long-cable application	Entry-level

System Specifications

Interface	
Serial Interface	RS-485 Data+, Data-
Transmission Distance	Max. 1,200 m at 9.6 kbps; Max. 400 m at 115.2 kbps (Belden 9841 2P twisted-pair cable, if different cables are used, the transmission distance may change)
2500 V _{DC} Isolated Voltage	2-way Isolation
Connector	Removable 7-Pin Terminal Block x 1; Removable 3-Pin Terminal Block x 1
LED Indicators	
Power/Communication	Yes
Power	
Input Voltage Range	+10 V _{DC} ~ +30 V _{DC} (Non-isolated)
Power Consumption	0.6 W
Environment	
Operating Temperature	-25 °C ~ +75 °C
Storage Temperature	-30 °C ~ +75 °C
Humidity	10 ~ 90% RH, non-condensing

Applications

RS-485 to RS-485 Repeater (Only for half duplex application)

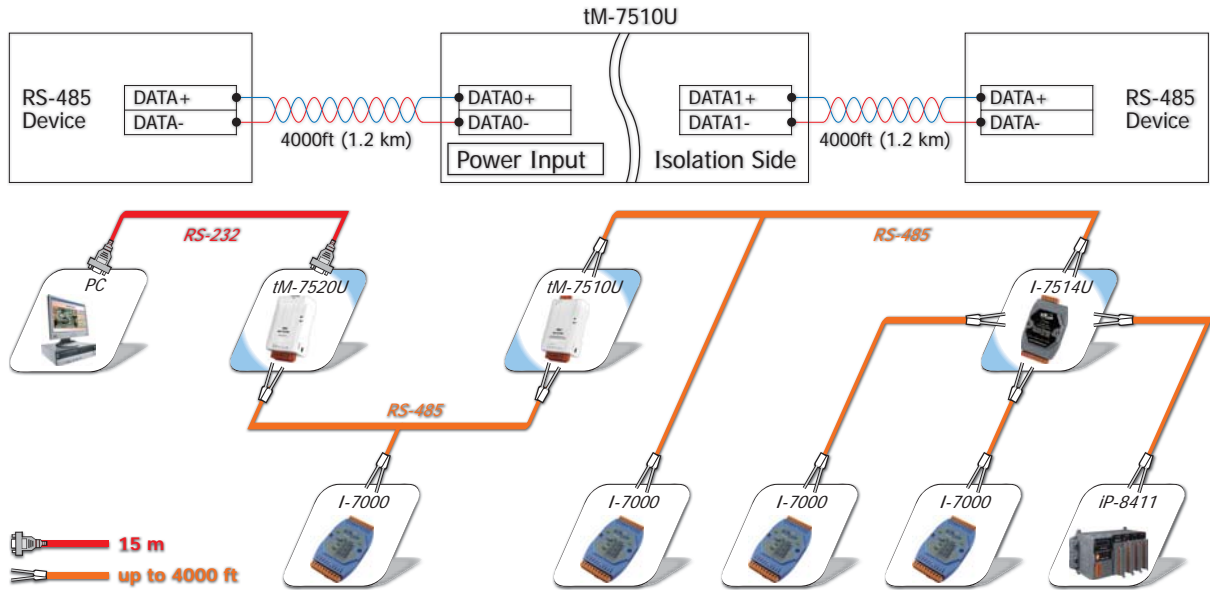

Pin Assignments

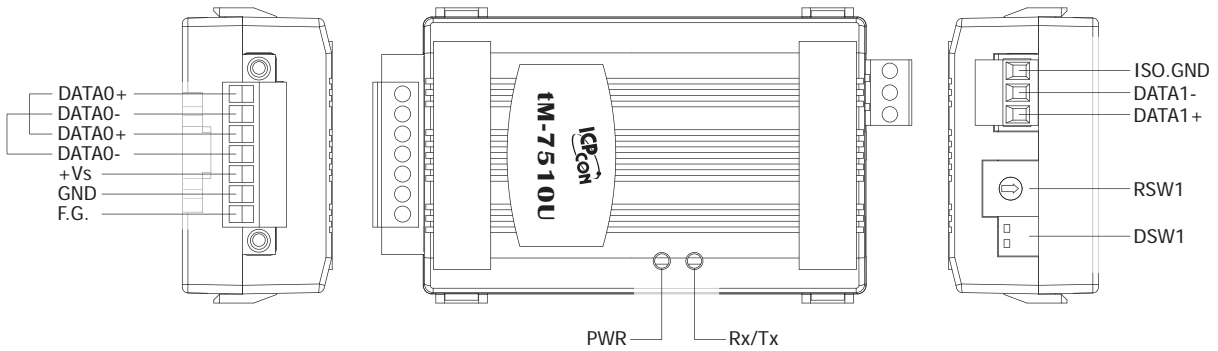

Dimensions (Unit: mm)

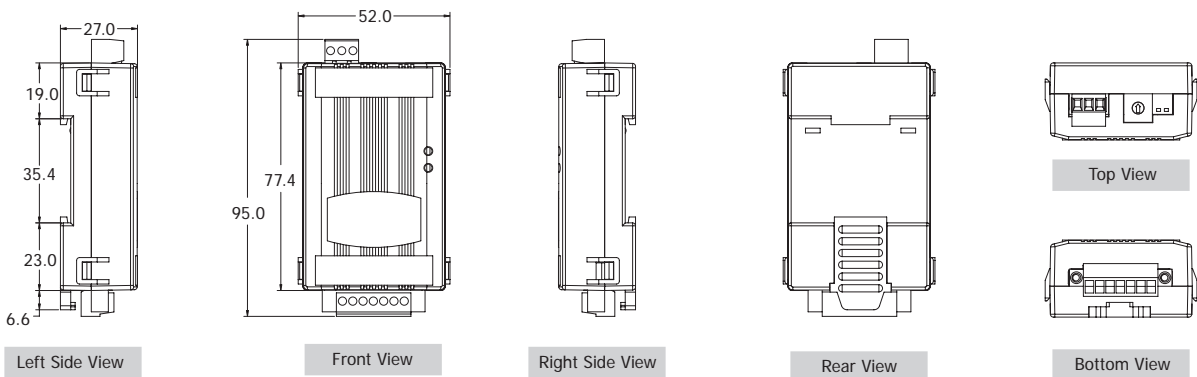

Ordering Information

tM-7510U CR	Isolated RS-485 Repeater (RoHS)
-------------	---------------------------------

Accessories

GPSU06U-6	24 Vdc/0.25 A, 6 W Power Supply
DIN-KA52F	24 Vdc/1.04 A, 25 W Power Supply with DIN-Rail Mounting

I-7510

Isolated RS-485 Repeater

I-7510A

Isolated RS-422/485 Repeater/Converter

I-7510AR

Three Way Isolated RS-422/485 Repeater/Converter

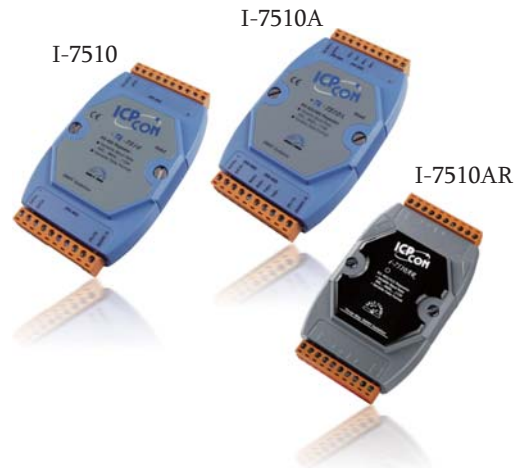
Features ▶▶▶

- Automatic RS-485 Direction Control
- 3-way 3000 V_{dc} Isolation Protection for I-7510AR
- Transmission Speed of up to 115200 bps
- Operating Temperatures, -25 °C ~ +75 °C
- 2-way 3000 V_{dc} Isolation Protection for I-7510/I-7510A
- ESD Protection for RS-485 Data Line
- Power Input, +10 ~ +30 V_{dc}
- DIN-Rail Mounting

Introduction

The I-7510/I-7510A provides 2-way optical isolation between one piece of RS-422/RS-485 equipment and the rest of the system. It can also be used as a repeater to extend the transmission of an existing network. Additionally, an RS-485 system can be expanded beyond the 256 node limitation imposed by the standard. It can also be used to convert a four-wire RS-422 signal into a 2-wire RS-485 signal, and vice versa.

The I-7510AR is exactly the same as the I-7510A, except for the isolation side. The isolation side of the I-7510A is located in the input interface circuit, but the isolation side of the I-7510AR is located in the input and output interface circuit. In other words the I-7510AR is 3-way isolation repeater module.

System Specifications

Models		I-7510	I-7510A	I-7510AR
Interface				
Serial Interface	RS-422	–	TxD+, TxD-, RxD+, RxD- The RS-422 and RS-485 cannot be used simultaneously	
	RS-485	Data+, Data-		
Transmission Distance		Max. 1,200 m at 9.6 kbps; Max. 400 m at 115.2 kbps (Belden 9841 2P twisted-pair cable, if different cables are used, the transmission distance may change)		
Self-Tuner Asic Inside		Yes		
Speed		300 ~ 115200 bps		
ESD Protection		Yes		
3000 V _{dc} Isolated Voltage		2-way Isolation		3-way Isolation
Connector		Removable 10-Pin Terminal Block x 2		
LED Indicators				
Power/Communication		Yes		
Power				
Input Voltage Range		+10 V _{dc} ~ +30 V _{dc} (Non-isolated)		
Power Consumption		2.16 W		
Mechanical				
Casing		Plastic		
Flammability		Fire-Retardant Materials (UL94-V0 Level)		
Dimensions (W x H x D)		72 mm x 122 mm x 35 mm		
Installation		DIN-Rail Mounting		
Environment				
Operating Temperature		-25 °C ~ +75 °C		
Storage Temperature		-30 °C ~ +75 °C		
Humidity		10 ~ 90% RH, non-condensing		

Applications

Applications for RS-422/485

RS-422 to RS-485 Converter (Only for half duplex application)

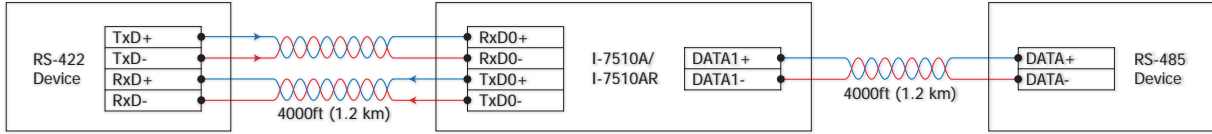

RS-485 to RS-485 Repeater (Only for half duplex application)

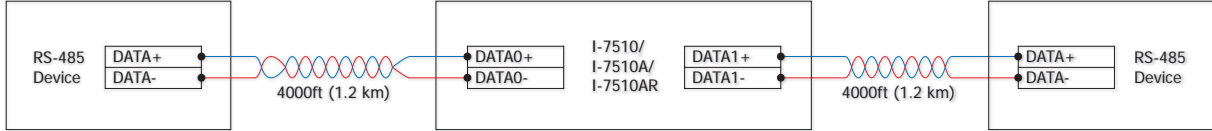

RS-422 to RS-422 Repeater

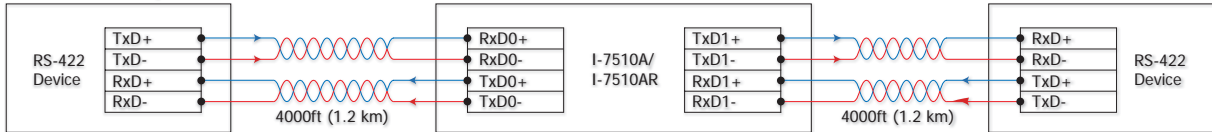

Application for 3-way isolation

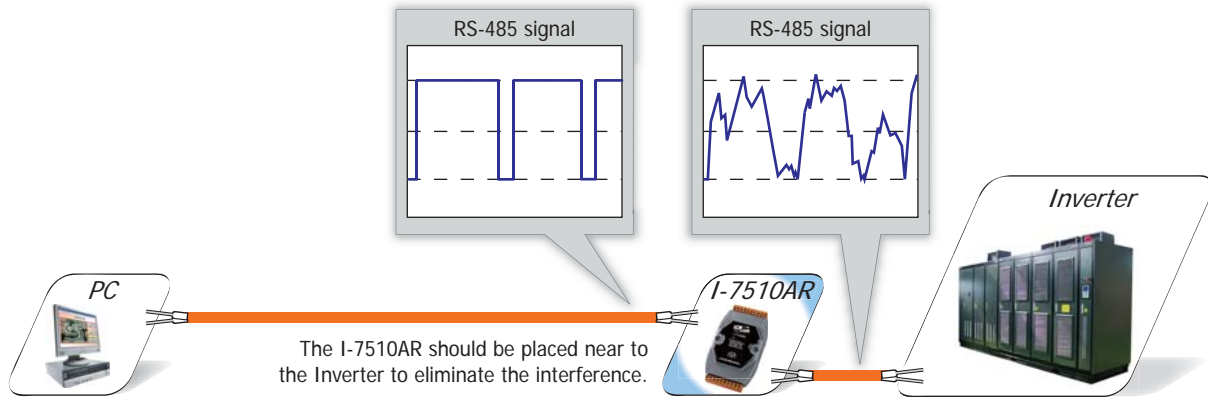

Pin Assignments

I-7510				I-7510A		I-7510AR		I-7510A/7510AR	
Terminal No.	Pin Assignment	Terminal No.	Pin Assignment	Terminal No.	Pin Assignment	Terminal No.	Pin Assignment	Terminal No.	Pin Assignment
01	DATA+	20	DATA1+	RS-485	01 DATA0+	20	DATA1+	RS-485	20 DATA1+
02	DATA-	19	DATA1-	02	DATA0-	19	DATA1-	19	DATA1-
03	--	18	--	03	--	18	--	18	--
04	--	17	--	04	RxD0+	17	TxD0+	17	TxD1+
05	--	16	--	05	RxD0-	16	TxD0-	16	TxD1-
06	--	15	--	06	TxD0+	15	RxD0+	15	RxD1+
07	--	14	--	07	TxD0-	14	RxD0-	14	RxD1-
08	--	13	--	08	--	13	--	13	--
09	(R)+Vs	12	--	09	(R)+Vs	12	(R)+Vs	12	--
10	(B)GND	11	--	10	(B)GND	11	(B)GND	11	--

Ordering Information

I-7510 CR	Isolated RS-485 Repeater (RoHS)
I-7510A CR	Isolated RS-422/485 Repeater/Converter (RoHS)
I-7510AR CR	Three Way Isolated RS-422/485 Repeater/Converter (RoHS)

Accessories

GPSU06U-6	24 Vdc/0.25 A, 6 W Power Supply
DIN-KA52F	24 Vdc/1.04 A, 25 W Power Supply with DIN-Rail Mounting

4-3 RS-485 Repeater/Hub/Splitter

I-7514U **NEW**

Isolated 4 Channels RS-485 Repeater/Hub/Splitter



Features ▶▶▶▶

- RS-485 Splitter
- True RS-485 Star Wiring Hub
- Power and data flow indicator for troubleshooting
- Easy-to-use rotary switch for fixed baud rate setting, 1200 ~ 115200 bps
- Independent RS-485 driver for each channel
- Automatic RS-485 Direction Control
- 120 Ω termination resistor for each channel
- Operating Temperatures, -25 °C ~ +75 °C
- DIN-Rail Mounting

Introduction

RS-485 Active Hub

The I-7514U is a 4-ch RS-485 active star wiring hub, it has 4 independent RS-485 output channels and one RS-485 input channel. Each output channel is equipped with an individual driver. The data from a master to the input channel will simultaneously be forwarded to all the four output channels.

Splitter

Data coming from the master input will be transmitted to all four RS-485 slave channels. But data coming from the slave channels will be returned to the master input only. Thus reduces the possibility of interference between each RS-485 slave loop and makes the RS-485 networks more robust and reliable.

Baud Rate Setting

The I-7514U provides 2 modes of baud rate setting, one is Self-Tuner mode and the other is fixed baud rate mode. The Self-Tuner mode can support multiple baud rate and multiple data format. The Self-Tuner design is exactly the same as I-7513 and I-7510 series. The Fixed baud rate mode offers a better quality for data transmission over long or lossy lines or electrically noisy environments.

RS-485 Short-Circuit

The Short-circuit protection can automatically shut off the breakdown channel, this kind of design can suffice to protect the communication system. When a connected RS-485 equipment breaks down, the breakdown channel will be isolated to ensure that other equipments work normally.

Termination resistors

In some critical environments, you may need to add termination resistors to prevent the reflection of serial signals. The I-7514U includes a jumper-selectable 120 Ω termination resistor for each channel (Default disable).

LED Indicators

The I-7514U has 6 LED to indicate the power status and network traffic. The TxD/RxD LED will flash when the unit is being sent out or received data.

System Specifications

Interface	
Input (Master)	1 RS-485 Channel: Data+, Data-
Output (Slave)	4 RS-485 Channels: Data+, Data-
Transmission Distance	Max. 1,200 m at 9.6 kbps; Max. 400 m at 115.2 kbps (Belden 9841 2P twisted-pair cable, if different cables are used, the transmission distance may change)
Self-Tuner Asic Inside	Yes
Speed	300 ~ 115200 bps via Self-Tuner mode; 1200 ~ 115200 bps via Fixed Baud Rate mode
ESD Protection	Yes
2500 Vdc Isolation on CH1 ~ CH4	2-way Isolation
Connector	Removable 10-Pin Terminal Block x 1; Removable 6-Pin Terminal Block x 1
LED Indicators	
Power/Communication	Yes
Power	
Input Voltage Range	+10 Vdc ~ +30 Vdc (Non-isolated)
Power Consumption	1.2 W
Mechanical	
Casing	Plastic
Flammability	Fire-Retardant Materials (UL94-V0 Level)
Dimensions (W x H x D)	72 mm x 122 mm x 35 mm
Installation	DIN-Rail Mounting
Environment	
Operating Temperature	-25 °C ~ +75 °C
Storage Temperature	-30 °C ~ +75 °C
Humidity	10 ~ 90% RH, non-condensing

Applications

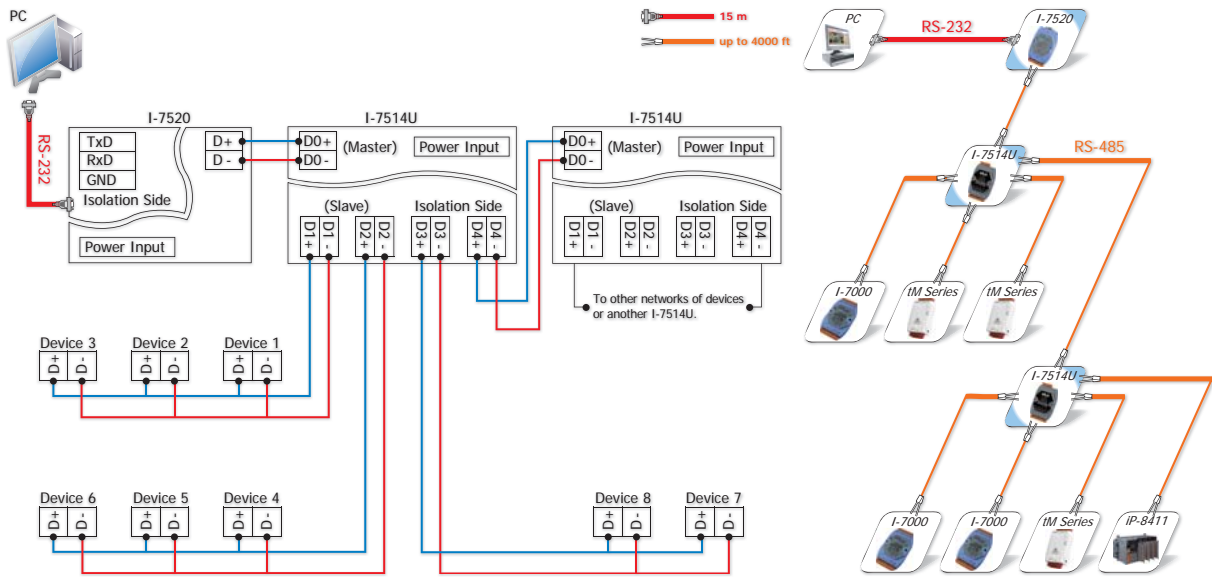

RS-485 Splitter

The following block diagram shows how I-7514U was designed as independent channel. Data coming from the master input will be transmitted to all four RS-485 slave channels. But data coming from the slave channels will be returned to the master input only. Thus reduces the possibility of interference between each RS-485 slave loop and makes the RS-485 networks more robust and reliable.

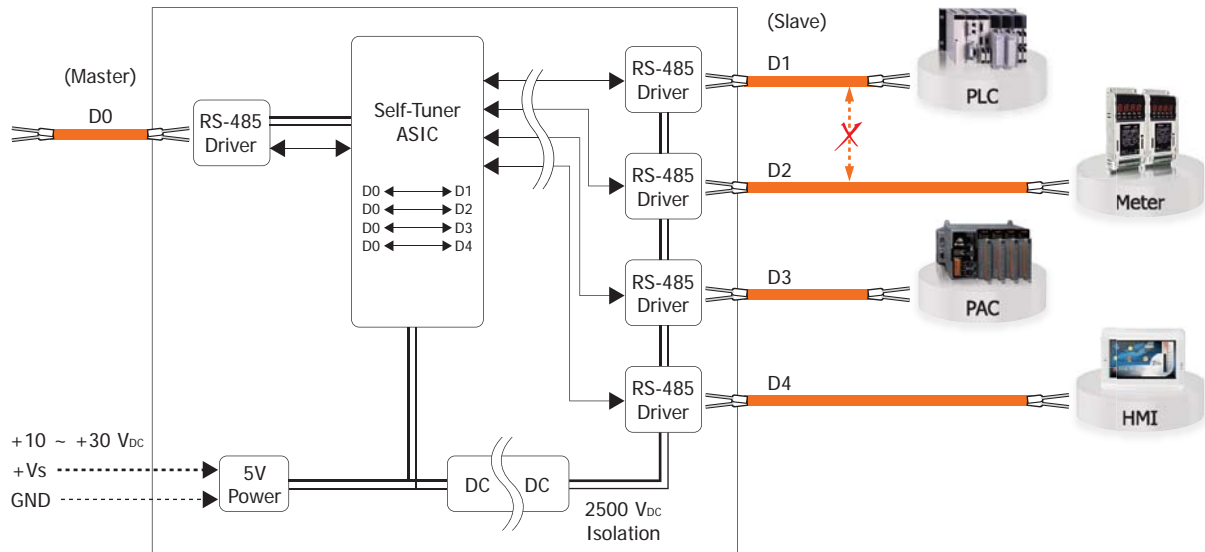

Dimensions (Unit: mm)

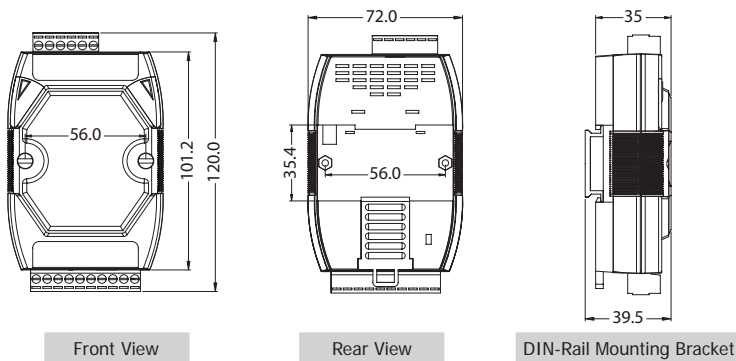

Ordering Information

I-7514U-G CR	Isolated 4 Channels RS-485 Active Hub (Gray Cover) (RoHS)
--------------	---

Accessories

GPSU06U-6	24 Vdc/0.25 A, 6 W Power Supply
DIN-KA52F	24 Vdc/1.04 A, 25 W Power Supply with DIN-Rail Mounting

4-4 RS-232/RS-422/485 Converters

tM-7520U **NEW**

Isolated RS-232 to RS-485 Converter



Features ▶▶▶

- 2-way 2500 V_{DC} Isolation Protection
- ESD Protection for RS-485 Data Line
- Power Input, +10 ~ +30 V_{DC}
- Low power consumption
- Long-cable application
- Power and data flow indicator for troubleshooting
- Easy-to-use rotary switch for baud rate setting, 1200 ~ 115200 bps
- Operating Temperatures, -25 °C ~ +75 °C
- Tiny packaging fits on your DIN-Rail Mounting

Introduction

Most industrial computer systems provide standard RS-232 serial ports with limited transmission speed, range, and networking capabilities. The RS-485 standards overcome these limitations by using differential voltage lines for data and control signals. The tM-7520U transparently converts RS-232 signals into isolated RS-485 signal with no need to change any hardware or software. This lets you easily build an industrial grade, long-distance communication system using standard PC hardware. The module provides 2500 V_{DC} of optical isolation allowing you to separate and protect critical segments of the system from the rest of the RS-485 network.

The tM-7520U provides 2 modes of baud rate setting, one is Self-Tuner mode and the other is Fixed baud rate mode. The Self-Tuner mode can support multiple baud rate and multiple data format. The Self-Tuner design is exactly the same as I-7520 series. The Fixed baud rate mode offers a better quality for data transmission over long or lossy lines or electrically noisy environments.

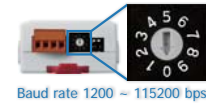

Baud rate 1200 ~ 115200 bps

Comparison Table of Repeater

Mode name	tM-7520U	I-7520
RS-485 Direction Control	Fixed baud rate setting and Automatic RS-485 Direction Control (Self-Tuner, default)	Automatic RS-485 Direction Control (Self-Tuner)
Baud rate	300 ~ 115200 bps for Self-Tuner 1200 ~ 115200 bps for Fixed baud rate setting	300 ~ 115200 bps
Dimensions (W x H x D)	52 mm x 92 mm x 27 mm	72 mm x 118 mm x 35 mm
Remarks	Entry-level Long-cable application	Entry-level

System Specifications

Interface	
Input	RS-232: TxD, RxD and GND
Output	RS-485: Data+, Data-
Transmission Distance	Max. 1,200 m at 9.6 kbps; Max. 400 m at 115.2 kbps (Belden 9841 2P twisted-pair cable, if different cables are used, the transmission distance may change)
2500 V _{DC} Isolated Protection	Yes
Connector	Removable 4-Pin Terminal Block x 1; 9-Pin Female D-Sub x 1
LED Indicators	
Power/TxD/RxD	Yes
Power	
Input Voltage Range	+10 V _{DC} ~ +30 V _{DC} (Non-isolated)
Power Consumption	0.5 W
Environment	
Operating Temperature	-25 °C ~ +75 °C
Storage Temperature	-30 °C ~ +75 °C
Humidity	10 ~ 90% RH, non-condensing

Applications

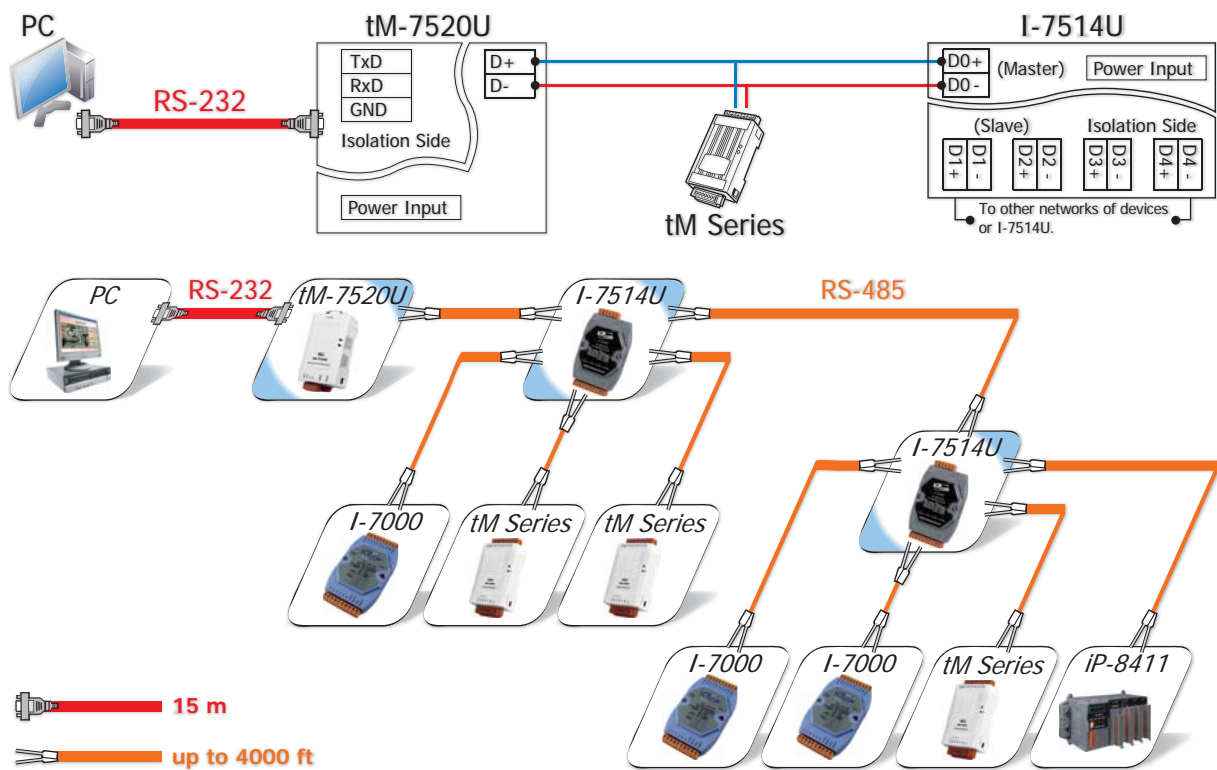

Pin Assignments

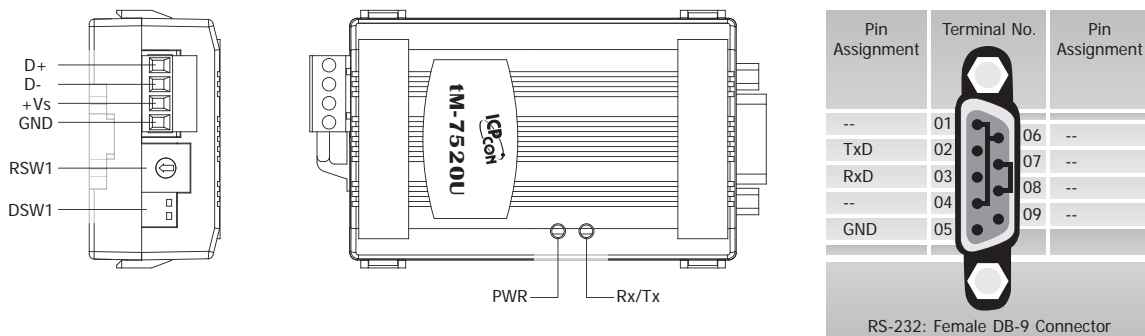

Dimensions (Unit: mm)

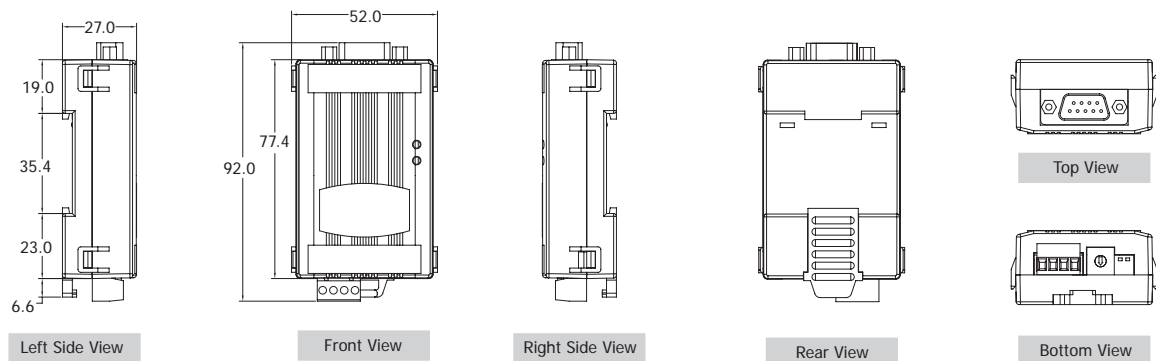

Ordering Information

tM-7520U CR	Isolated RS-232 to RS-485 Converter (RoHS)
tM-7520U-CA CR	tM-7520U CR with CA-0915 cable x 1 (RoHS)

Accessories

GPSU06U-6	24 Vdc/0.25 A, 6 W Power Supply
DIN-KA52F	24 Vdc/1.04 A, 25 W Power Supply with DIN-Rail Mounting
tM-7510U CR	Isolated RS-485 Repeater (RoHS)
CA-0915	9-Pin Male-Female D-Sub Cable, 1.5 m

I-7520U4 *NEW*

Isolated RS-232 to 4 Channels RS-485 Active Star Wiring Hub

Features ▶▶▶▶

- True RS-485 Star Wiring Hub
- Power and data flow indicator for troubleshooting
- Easy-to-use rotary switch for fixed baud rate setting, 1200 ~ 115200 bps
- Power Input, +10 ~ +30 V_{dc}
- Independent RS-485 driver for each channel
- Automatic RS-485 Direction Control
- 120 Ω termination resistor for each channel
- Operating Temperatures, -25 °C ~ +75 °C
- DIN-Rail Mounting

Introduction
RS-485 Active Hub

The I-7520U4 is isolated RS-232 to 4-ch RS-485 active star wiring hub, it has 4 independent RS-485 output channels and one RS-485 input channel. Each output channel is equipped with an individual driver. The data from a master to the input channel will simultaneously be forwarded to all the four output channels.

Baud Rate Setting

The I-7520U4 provides 2 modes of baud rate setting, one is Self-Tuner mode and the other is fixed baud rate mode. The Self-Tuner mode can support multiple baud rate and multiple data format. The Self-Tuner design is exactly the same as I-7520 series. The Fixed baud rate mode offers a better quality for data transmission over long or lossy lines or electrically noisy environments.

RS-485 Short-Circuit

The Short-circuit protection can automatically shut off the breakdown channel, this kind of design can suffice to protect the communication system. When a connected RS-485 equipment breaks down, the breakdown channel will be isolated to ensure that other equipments work normally.

Termination resistors

In some critical environments, you may need to add termination resistors to prevent the reflection of serial signals. The I-7520U4 includes a jumper-selectable 120Ω termination resistor for each channel (Default disable).

LED Indicators

The I-7520U4 has 6 LED to indicate the power status and network traffic. The TxD/RxD LED will flash when the unit is being sent out or received data.

System Specifications

Interface	
Input	1 RS-232 Channel: TxD, RxD and GND
Output	4 RS-485 Channels: Data+, Data-
Transmission Distance	Max. 1,200 m at 9.6 kbps; Max. 400 m at 115.2 kbps (Belden 9841 2P twisted-pair cable, if different cables are used, the transmission distance may change)
Self-Tuner Asic Inside	Yes
Speed	300 ~ 115200 bps via Self-Tuner mode; 1200 ~ 115200 bps via Fixed Baud Rate mode
ESD Protection	Yes
2500 V _{dc} Three Way Isolated Protection	Yes
Connector	Removable 10-Pin Terminal Block x 1; 9-Pin Female D-Sub x 1
LED Indicators	
Power/Communication	Yes
Power	
Input Voltage Range	+10 V _{dc} ~ +30 V _{dc} (Non-isolated)
Power Consumption	1.2 W
Mechanical	
Casing	Plastic
Flammability	Fire-Retardant Materials (UL94-V0 Level)
Dimensions (W x H x D)	72 mm x 118 mm x 35 mm
Installation	DIN-Rail Mounting
Environment	
Operating Temperature	-25 °C ~ +75 °C
Storage Temperature	-30 °C ~ +75 °C
Humidity	10 ~ 90% RH, non-condensing

Applications

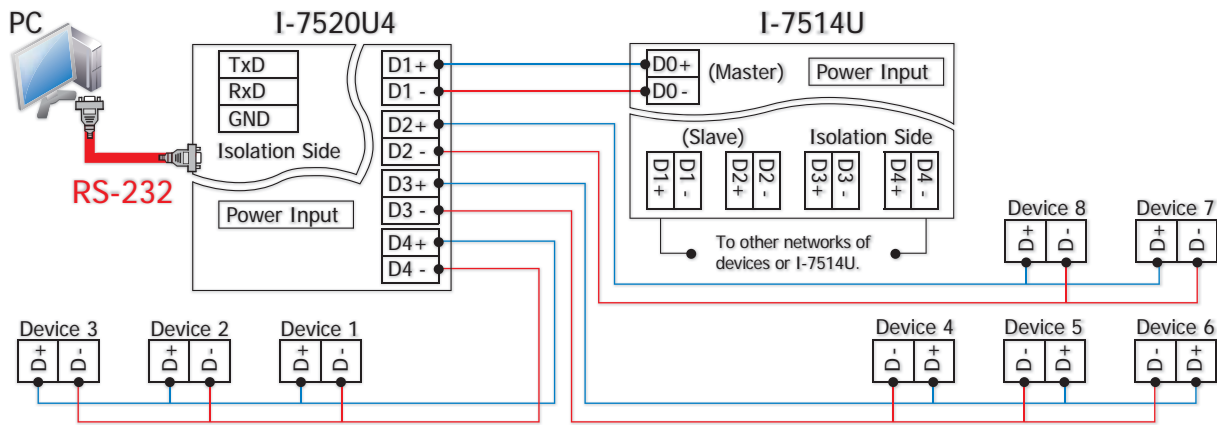

Pin Assignments

Terminal No.	Pin Assignment	Pin Assignment	Terminal No.	Pin Assignment
01	D1 +	--	01	--
02	D1 -	TxD	02	--
03	D2 +	RxD	03	--
04	D2 -	--	04	--
05	D3 +	GND	05	--
06	D3 -			
07	D4 +			
08	D4 -			
09	(R) +Vs			
10	(B) GND			



RS-232: Female DB-9 Connector

Dimensions (Unit: mm)

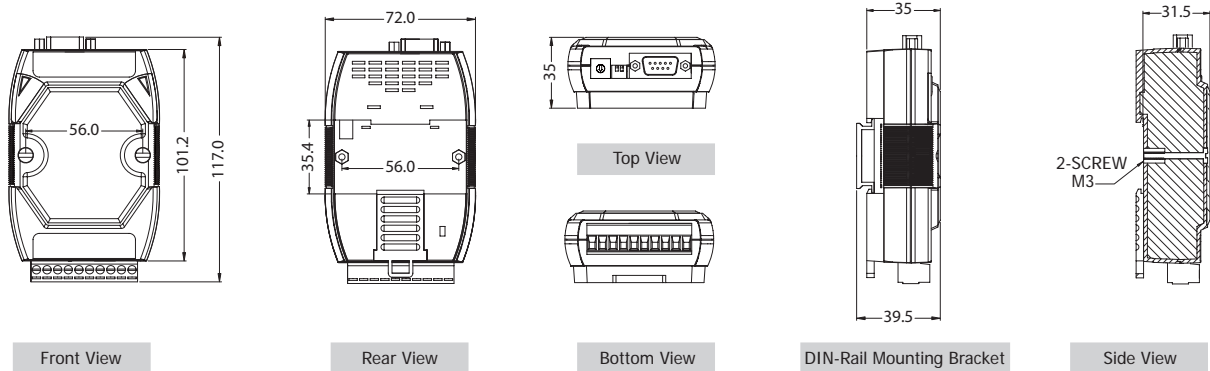

Ordering Information

I-7520U4-G CR	Isolated RS-232 to 4 Channels RS-485 Active Hub (Gray Cover) (RoHS)
I-7520U4-CA-G CR	I-7520U4-G CR with CA-0915 cable x 1

Accessories

GPSU06U-6	24 Vdc/0.25 A, 6 W Power Supply
DIN-KA52F	24 Vdc/1.04 A, 25 W Power Supply with DIN-Rail Mounting
I-7510 CR	Isolated RS-485 Repeater (RoHS)
CA-0915	9-Pin Male-Female D-Sub Cable, 1.5 m

PCISA-7520R

Isolated RS-232 to RS-485 Converter Card

PCISA-7520AR

Isolated RS-232 to RS-422/485 Converter Card

Features ▶▶▶▶

- No External Power Supply required
- No Driver installation required
- 3000 V_{dc} Isolation Protection
- Auto Switching Baud Rate, 300 ~ 115200 bps
- Transmission Speed of up to 115200 bps
- Can be used in an ISA Bus, a PCI Bus or any system with an RS-232 Interface

Introduction

The PCISA-7520 series card provides RS-232 to RS-485 (or RS-422) converter function that is exactly the same as I-7520 series. It is designed for easy installation, powered from the PCI or ISA Interface but without PCI and ISA functions. The PCISA-7520 series is equipped with one RS-232 serial port and one RS-485 serial port. The RS-232 port is designed to communicate with the local Host PC, the RS-485 is designed to communicate with the remote IO module.

For adding more serial ports to a PC, please refer to VXC/VEX series card in chapter 2.

System Specifications

Models		PCISA-7520R	PCISA-7520AR
Interface			
Serial Interface	RS-232	TxD, RxD, GND	
	RS-422	–	TxD+, TxD-, RxD+, RxD-
	RS-485	Data+, Data-	The RS-422 and RS-485 cannot be used simultaneously
Transmission Distance		Max. 1,200 m at 9.6 kbps; Max. 400 m at 115.2 kbps (Belden 9841 2P twisted-pair cable, if different cables are used, the transmission distance may change)	
Self-Tuner Asic Inside		Yes	
Speed		300 ~ 115200 bps	
ESD Protection		Yes	
Isolated Voltage		3000 V _{dc} on the RS-422/485 side	
Connector	RS-232	9-Pin Female D-Sub x 1	
	RS-422/485	9-Pin Male D-Sub x 1	
Power			
Input Voltage Range		+5 V _{dc} from the PC	
Power Consumption		1.0 W	
Mechanical			
Dimensions (L x W x D)		118 mm x 72 mm x 22 mm	
Environment			
Operating Temperature		0 °C ~ +50 °C	
Storage Temperature		-20 °C ~ +70 °C	
Humidity		0 ~ 90% RH, non-condensing	

Applications

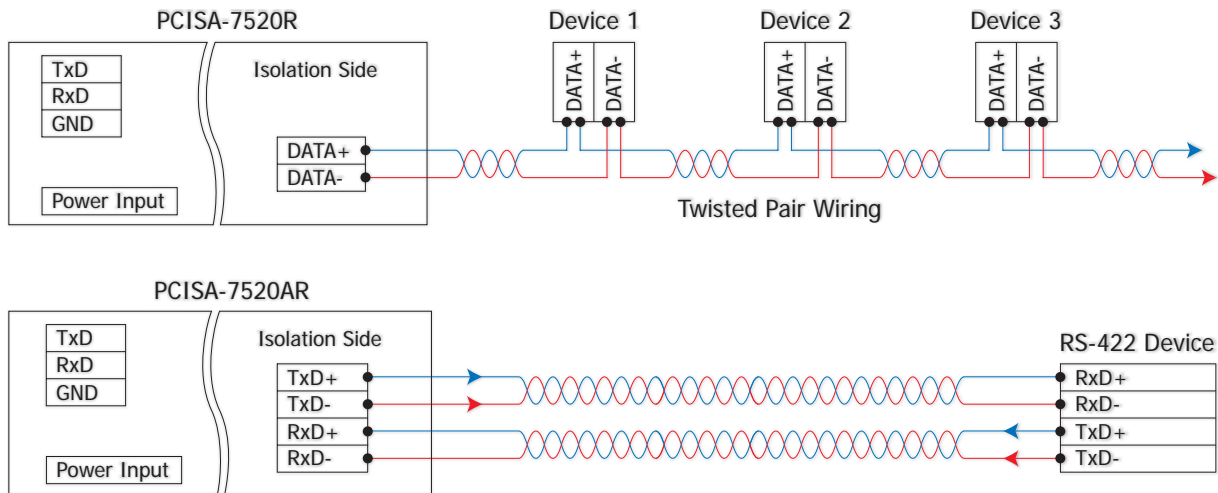

Pin Assignments

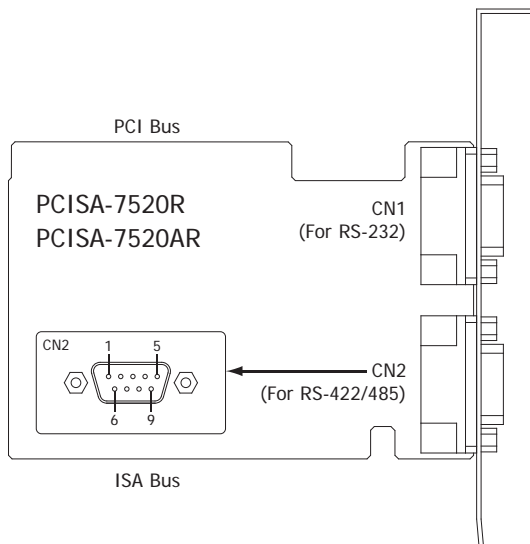

PCISA-7520R		PCISA-7520AR	
Pin	2-wire for RS-485	Pin	2-wire for RS-485 / 4-wire for RS-422
01	DATA+	01	DATA+ / Tx+
02	DATA+	02	DATA+ / Tx+
03	NC	03	NC
04	NC	04	NC / Rx+
05	NC	05	NC / Rx+
06	DATA-	06	DATA- / Tx-
07	DATA-	07	DATA- / Tx-
08	NC	08	NC / Rx-
09	NC	09	NC / Rx-

Dimensions (Unit: mm)

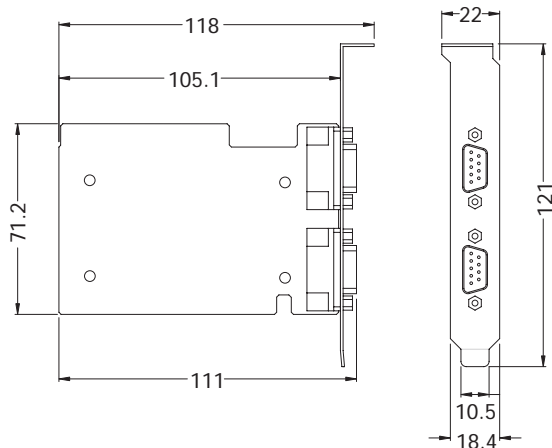

Ordering Information

PCISA-7520R CR	Isolated RS-232 to RS-485 Converter Card (RoHS)
PCISA-7520AR CR	Isolated RS-232 to RS-422/485 Repeater (RoHS)

Accessories

I-7510 CR	Isolated RS-485 Repeater (RoHS)
I-7510A CR	Isolated RS-422/485 Repeater (RoHS)
CA-0915	9-Pin Male-Female D-Sub Cable, 1.5 m

I-7520

Isolated RS-232 to RS-485 Converter

I-7520A

Isolated RS-232 to RS-422/485 Converter

I-7520R

RS-232 to Isolated RS-485 Converter

I-7520AR

RS-232 to Isolated RS-422/485 Converter

Features ▶▶▶▶

- Automatic RS-485 Direction Control
- ESD Protection for the RS-232/422/485 Data Line
- Power Input, +10 ~ +30 V_{DC}
- DIN-Rail Mounting
- 3000 V_{DC} Isolation Protection on the RS-485 side
- Transmission Speed of up to 115200 bps
- Operating Temperatures, -25 °C ~ +75 °C

Introduction

Most industrial computer systems provide standard RS-232 serial ports. Though widely accepted, RS-232 has limited transmission speed, range, and networking capabilities. The RS-422 and RS-485 standards overcome these limitations by using differential voltage lines for data and control signals, which transparently converts RS-232 signals into isolated RS-422 or RS-485 signal with no need to change any hardware or software. The I-7520/I-7520A lets you easily build an industrial grade, long-distance communication system using standard PC hardware.

The design of the isolation between the I-7520 and the I-7520R/AR is different. If the user wants to supply power from the PLC/PC, the I-7520R/AR should be used, otherwise the isolation will be broken. Refer to the I-7000 bus converter manual for detailed information.

System Specifications

Models	I-7520	I-7520R	I-7520A	I-7520AR
Interface				
Serial Interface	RS-232	TxD, RxD, GND		
	RS-422	-		TxD+, TxD-, RxD+, RxD- The RS-422 and RS-485 cannot be used simultaneously
	RS-485	Data+, Data-		
Transmission Distance	Max. 1,200 m at 9.6 kbps; Max. 400 m at 115.2 kbps (Belden 9841 2P twisted-pair cable, if different cables are used, the transmission distance may change)			
Self-Tuner Asic Inside	Yes			
Speed	300 ~ 115200 bps			
ESD Protection	Yes			
3000 V _{DC} Isolated Voltage	on RS-232 side	on RS-485 side	on RS-232 side	on RS-485 side
Connector	RS-232	9-Pin Female D-Sub		
	RS-422/485	Removable 10-Pin Terminal Block		
LED Indicators				
Power/Communication	Yes			
Power				
Input Voltage Range	+10 V _{DC} ~ +30 V _{DC} (Non-isolated)			
Power Consumption	1.2 W			
Mechanical				
Casing	Plastic			
Flammability	Fire-Retardant Materials (UL94-V0 Level)			
Dimensions (W x H x D)	72 mm x 118 mm x 35 mm			
Installation	DIN-Rail Mounting			
Environment				
Operating Temperature	-25 °C ~ +75 °C			
Storage Temperature	-30 °C ~ +75 °C			
Humidity	10 ~ 90% RH, non-condensing			

Applications

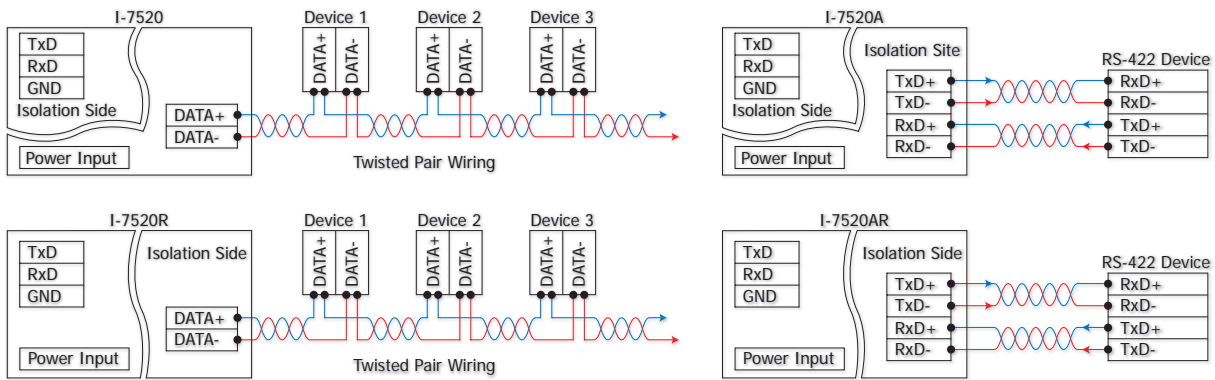

Pin Assignments

I-7520/I-7520R					I-7520A/I-7520AR				
Terminal No.	Pin Assignment	Pin Assignment	Terminal No.	Pin Assignment	Terminal No.	Pin Assignment	Pin Assignment	Terminal No.	Pin Assignment
RS-485	01	DATA+	01	06	RS-485	01	DATA1+	01	06
	02	DATA-	02	07		02	DATA1-	02	07
	03	--	03	08		03	--	03	08
	04	--	04	09		04	TxD+	04	09
	05	--	05	05		05	TxD-	05	05
	06	--	06	04		06	RxD+/DATA2+	06	04
	07	--	07	03		07	RxD-/DATA2-	07	03
	08	--	08	02		08	--	08	02
	09	(R)+Vs	09	01		09	(R)+Vs	09	01
	10	(B)GND	10	10		10	(B)GND	10	10

RS-232: Female DB-9 Connector

Dimensions (Unit: mm)

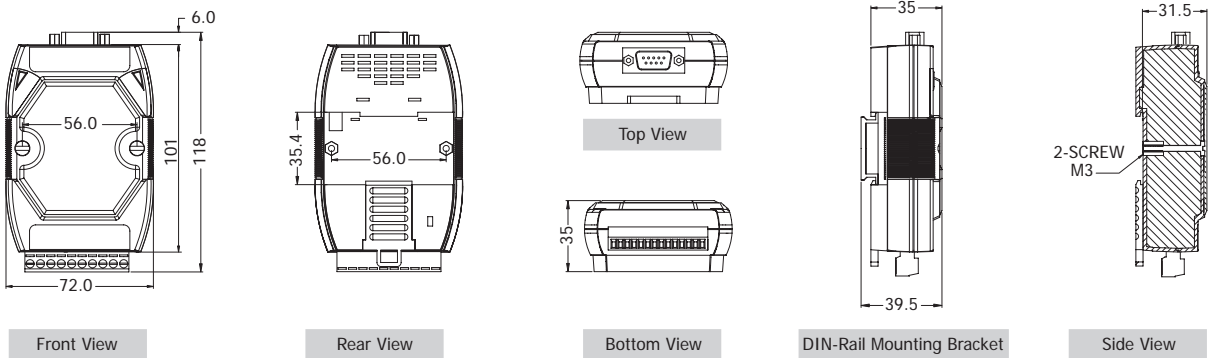

Ordering Information

I-7520 CR	Isolated RS-232 to RS-485 Converter (RoHS)
I-7520A CR	Isolated RS-232 to RS-422/485 Converter (RoHS)
I-7520-G CR	Isolated RS-232 to RS-485 Converter (Gray Cover) (RoHS)
I-7520A-G CR	Isolated RS-232 to RS-422/485 Converter (Gray Cover) (RoHS)
I-7520R CR	RS-232 to Isolated RS-485 Converter (RoHS)
I-7520AR CR	RS-232 to Isolated RS-422/485 Converter (RoHS)
I-7520R-G CR	RS-232 to Isolated RS-485 Converter (Gray Cover) (RoHS)
I-7520AR-G CR	RS-232 to Isolated RS-422/485 Converter (Gray Cover) (RoHS)

Accessories

GPSU06U-6	24 Vdc/0.25 A, 6 W Power Supply
DIN-KA52F	24 Vdc/1.04 A, 25 W Power Supply with DIN-Rail Mounting
I-7510 CR	Isolated RS-485 Repeater (RoHS)
I-7510A CR	Isolated RS-422/485 Repeater (RoHS)
CA-0915	9-Pin Male-Female D-Sub Cable, 1.5 m

I-7551

Isolated RS-232 to RS-232 Converter



Features ▶▶▶▶

- 3000 V_{dc} 3-way Isolation Protection
- Transmission Speed of up 115200 bps
- Operating Temperatures, -25 °C ~ +75 °
- ESD Protection
- Power Input, +10 ~ +30 V_{dc}
- DIN-Rail Mounting

4

4

Converters, Repeaters, Hubs and Splitter

Introduction

The I-7551 provides a complete full-duplex (including control signal) electrical isolation channel between two RS-232 devices. This isolation is an important consideration if a system uses different power sources, has noisy signals, or must operate at different ground potentials.

The CTS/RTS pins of the I-7551 module can be reconfigured as DSR/DTR to meet requirements on different applications.

The I-7551 incorporates two DC-to-DC converters, the isolation side of the I-7551 is located in the input and output interface circuit. In other words, the I-7551 is 3-way isolated RS-232 to RS-232 converter.

System Specifications

Interface		
Input	TxD, RxD, CTS, RTS, GND (Default) or TxD, RxD, DSR, DTR, GND Jumpers JP1 and JP2 are used to select the RS-232 input source type	
Output	TxD, RxD, CTS, RTS, GND (Default) or TxD, RxD, DSR, DTR, GND	
Transmission Distance	Max. 15 M at 115200 bps	
Speed	300 ~ 115200 bps	
ESD Protection	Yes	
3000 V _{dc} Three Way Isolated Protection	Yes	
Connector	RS-232 Input	9-Pin Female D-Sub
	RS-232 Output	9-Pin Male D-Sub
LED Indicators		
Power/Communication	Yes	
Power		
Input Voltage Range	+10 V _{dc} ~ +30 V _{dc} (Non-isolated)	
Power Consumption	1.2 W	
Mechanical		
Casing	Plastic	
Flammability	Fire-Retardant Materials (UL94-V0 Level)	
Dimensions (W x H x D)	72 mm x 118 mm x 35 mm	
Installation	DIN-Rail Mounting	
Environment		
Operating Temperature	-25 °C ~ +75 °C	
Storage Temperature	-30 °C ~ +75 °C	
Humidity	10 ~ 90% RH, non-condensing	

Applications

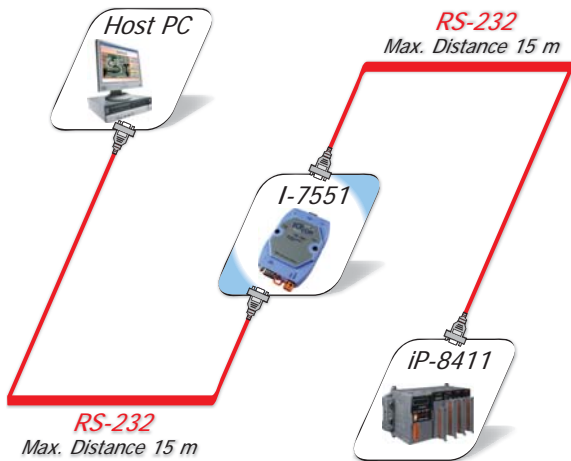

Pin Assignments

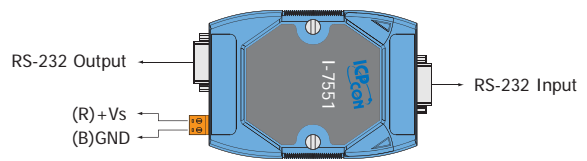

TxD, RxD, CTS, RTS, GND (Default)

RS-232 Input			RS-232 Output		
Pin Assignment	Terminal No.	Pin Assignment	Pin Assignment	Terminal No.	Pin Assignment
GND	01	06	--	05	09
TxD	02	07	CTS	04	08
RxD	03	08	RTS	03	07
--	04	09	--	RxD	02
--	05	--	--	--	01

Female DB-9 Connector Male DB-9 Connector

TxD, RxD, DTR, DSR, GND

RS-232 Input			RS-232 Output		
Pin Assignment	Terminal No.	Pin Assignment	Pin Assignment	Terminal No.	Pin Assignment
GND	01	06	DTR	05	09
TxD	02	07	--	04	08
RxD	03	08	--	03	07
--	04	09	DSR	RxD	02
--	05	--	--	--	01

Female DB-9 Connector Male DB-9 Connector

Internal I/O Structure

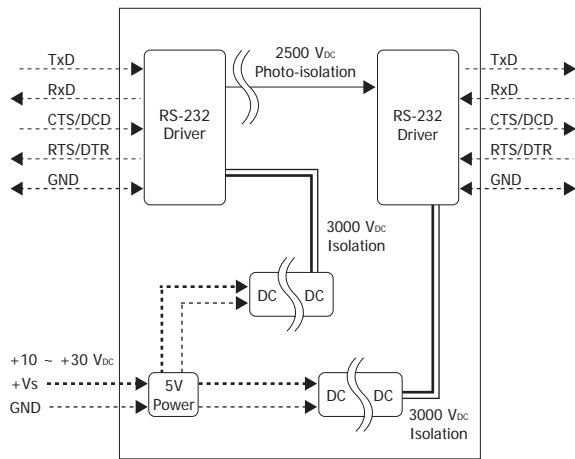

Dimensions (Unit: mm)

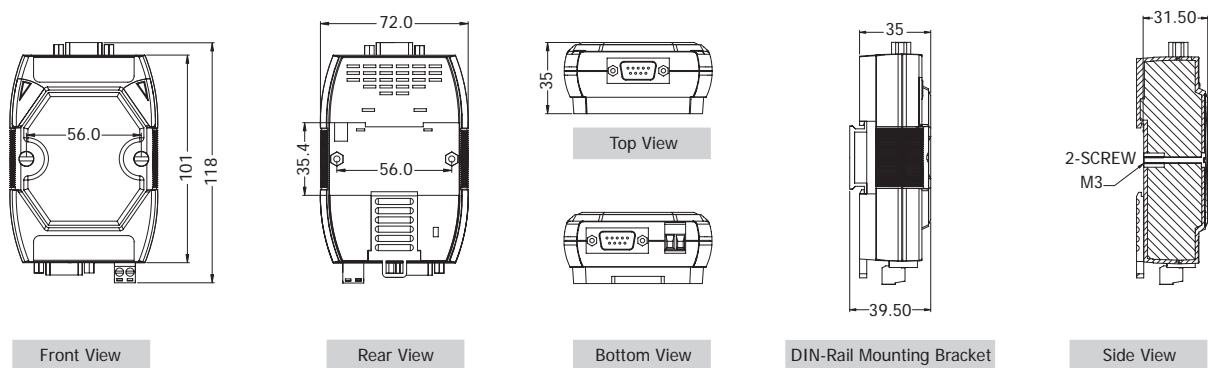

Ordering Information

I-7551 CR	Isolated RS-232 to RS-232 Converter (RoHS)
I-7551-G CR	Isolated RS-232 to RS-232 Converter (Gray Cover) (RoHS)

Accessories

GPSU06U-6	24 Vdc/0.25 A, 6 W Power Supply
DIN-KA52F	24 Vdc/1.04 A, 25 W Power Supply with DIN-Rail Mounting

4-5 Intelligent Communication Controllers

I-752N Series

Programmable Intelligent Communication Controller



Features ▶▶▶▶

- Built-in "Addressable RS-485 to RS-232 Converter" firmware
- Supports about 30 well-defined commands
- Supports power-up and safe value for DO
- R.O.C. Invention Patent No. 086674, No.103060 and No. 132457
- Programmable Intelligent Communication Controller
- Supports Dual-Watchdog commands
- Watchdog timer provides fault tolerance and recovery
- Low power consumption
- Made from fire-retardant materials (UL94-V0 Level)

Introduction

There are many RS-232 devices in industry applications. Nowadays it becomes important to link all those RS-232 devices together for automation and information. Usually those RS-232 devices are far away from the host-PC and widely distributed in the factory. So it is not a good idea to use multi-serial cards to connect all these RS-232 devices together. The I-752N series product can be used to link multiple RS-232 devices by a single RS-485 network. The RS-485 is famous for its easy maintenance, simple cabling, stable, reliable and low cost.

Onboard 1 KB Queue buffer

The I-752N series module is equipped with a 1 KB queue buffer for its local RS-232 device. All input data can be stored in the queue buffer until the Host PC has time to read it. This feature allows the Host PC to link thousands of RS-232 devices without any loss of data.

3000V isolation on RS-485 side

COM2 of the I-752N modules is an isolated RS-485 port with 3000 V_{DC} isolation, which protects the local RS-232 devices from transient noises coming from the RS-485 network.

Self-Tuner ASIC inside

The built-in Self-Tuner ASIC on an RS-485 port can auto detect and control the send/receive direction of the RS-485 network. Thus, there is no need for application programs to be concerned about direction control of the RS-485 network.

Can be used as Addressable RS-485 to RS-232 Converter

Most RS-232 devices don't support device addressing. The ICP DAS I-752N module assigns a unique address for each RS-232 device installed. When Host PC sends a command with a device address to the RS-485 network, the destination I-752N module will remove the address field, and then pass the other commands to the specified local RS-232 devices. The response from the local RS-232 devices will be returned to the Host PC via the I-752N.

Master-type Addressable RS-485 to RS-232 Converter

The ICP DAS I-752N product is unique that they are Master type converters which use our R.O.C. Patent 086674, while most other converters are Slave-type, which are helpless without a Host PC. In real industrial applications, many users are not satisfied with Slave-type converters as they cannot be adapted to individual requirement. The powerful I-752N series analyzes the local RS-232 devices, DI and DO without the need for a Host PC. Refer to Applications 5 ~ 9 for more information in the manual.

Can be used as RS-232 to RS-485 Device Server

The Device Server is an appliance that networking any device with a serial communication port. The I-752N series Intelligent Communication Controller allows the RS-232 serial devices to connect to the RS-485 network. Also, there are PDS series products available from ICP DAS, which provide Ethernet connectivity for serial devices.

Applications

- Factory Automation
- Building Automation
- Home Automation

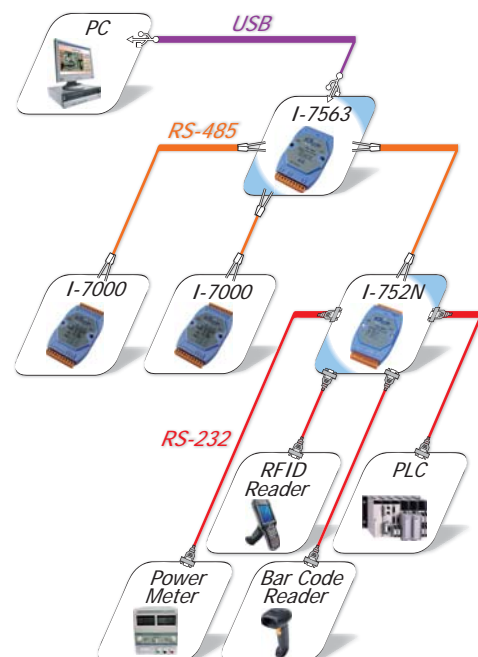

I/O Specifications

Models	I-7521(D)	I-7522(D)	I-7523(D)	I-7522A(D)	I-7524(D)	I-7527(D)
User-Defined I/O						
I/O Channel	3	–	–	–	–	–
Digital Output						
DI Channel	2	2	1	5	1	1
Input Type	Source (Dry Type), Common Ground, non-isolated					
Off Voltage	+1 V max.					
On Voltage	+3.5 V _{DC} ~ +30 V _{DC}					
Digital Output						
DO Channel	3	1	–	5	1	1
Output Type	Open Collector (Sink/NPN), non-isolated					
Load Voltage	+30 V _{DC} max.					
Load Current	100 mA max.					

System Specifications

Models	I-7521(D)	I-7522(D)	I-7523(D)	I-7522A(D)	I-7524(D)	I-7527(D)
System						
CPU	80188, 20 MHz					
SRAM	128 KB					
Flash	512 KB					
EEPROM	2 KB					
Real-Time Clock	–					
Watchdog Timer	Yes					
Operating System	MinIOS7					
Communication Interface						
COM1	5-wire RS-232 or 2-wire RS-485					
COM2	Isolated 2-wire RS-485			2-wire RS-485		
COM3	–	5-wire RS-232	5-wire RS-232	4-wire RS-422	5-wire RS-232	3-wire RS-232
COM4	–	–	3-wire RS-232	–	5-wire RS-232	3-wire RS-232
COM5	–	–	–	–	5-wire RS-232	3-wire RS-232
COM6	–	–	–	–	–	3-wire RS-232
COM7	–	–	–	–	–	3-wire RS-232
COM8	–	–	–	–	–	3-wire RS-232
Baud Rate	300 ~ 115200 bps					
Data Bit	COM1 ~ COM2: 7 or 8 COM3 ~ COM8: 5, 6, 7 or 8					
Parity	COM1 ~ COM2: None, Even, Odd COM3 ~ COM8: None, Even, Odd, Mark, Space					
Stop Bit	COM1 ~ COM2: 1 or 2 (data bit must be 7) COM3 ~ COM8: 1 or 2					
Connector	Male DB-9 x 1 13-Pin screw terminal block x 1 (for 16 ~ 26 AWG wires; 3.81 mm pitch)			14-Pin screw terminal block x 2 (for 16 ~ 22 AWG wires; 3.5 mm pitch)		
LED Indicators						
LED Display	5-digit 7-segment LED display for D versions					
Power						
Protection	Power input reverse polarity protection					
Power Requirement	Unregulated +10 V _{DC} ~ 30 V _{DC}					
Power Consumption	2 W (without display), 3 W (with display)					
Mechanical						
Casing	Plastic					
Flammability	Fire-Retardant Materials (UL94-V0 Level)					
Dimensions (W x H x D)	72 mm x 118 mm x 35 mm			72 mm x 120 mm x 35 mm		
Installation	DIN-Rail Mounting					
Environment						
Operating Temperature	-25 °C ~ +75 °C					
Storage Temperature	-40 °C ~ +80 °C					
Humidity	0 ~ 90% RH, non-condensing					
Note:						
3-wire RS-232: Rx, Tx, GND						
5-wire RS-232: Rx, Tx, CTS, RTS, GND						
2-wire RS-485: DATA+, DATA-, GND; Self-Tuner inside						
Isolated 2-wire RS-485: DATA+, DATA-, Self-Tuner inside; 3000 V _{DC} Isolation						
4-wire RS-422: Rx+, Rx-, Tx+, Tx-, GND						

Pin Assignments

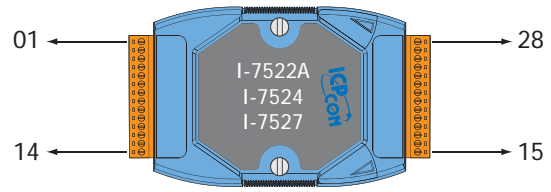
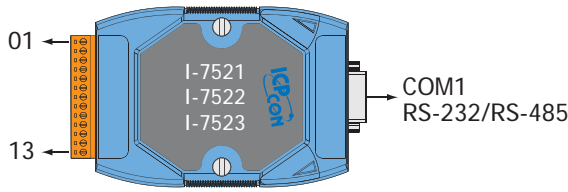

Terminal No.	Pin Assignment	Pin Assignment	Terminal No.	Pin Assignment	
01	X3	<p>COM1: RS-232 Male DB-9 Connector</p>	05	09 Data-	
02	X2		N.C.	04	08 RTS
03	X1		RxD	03	07 CTS
DO	04		DO3	02	06 N.C.
	05		DO2	01	
DI	06		DO1		
	07		DI3		
	08		DI2		
COM2	09		INIT*		
	10		(Y)D2+		
Power Input	11		(G)D2-		
	12		(R)+Vs		
	13		(B)GND		

Terminal No.	Pin Assignment	Terminal No.	Pin Assignment		
DO	01	DO			
DI	02	DI			
COM1	03	D1+	DO	28 DO3	
	04	D1-	27	DO2	
	05	CTS1	26	DO1	
	06	RTS1	25	DO0	
	07	GND	24	DO.PWR	
	08	TxD1	23	GND	
	09	RxD1	DI	22	DI3
	10	INIT*		21	DI2
	11	(Y)D2+		20	DI1
COM2	12	(G)D2-	19	DI0	
	13	(R)+Vs	COM3	18	RxD3-
Power Input	14	(B)GND		17	RxD3+
				16	TxD3-
			15	TxD3+	

Terminal No.	Pin Assignment	Pin Assignment	Terminal No.	Pin Assignment	
COM3	01	CTS3	<p>COM1: RS-232 Male DB-9 Connector</p>	09	Data-
	02	RTS3		04	08 RTS
	03	RxD3		03	07 CTS
	04	TxD3		02	06 N.C.
	05	GND		01	
DO	06	DO1			
DI	07	DI3			
	08	DI2			
COM2	09	INIT*			
	10	(Y)D2+			
Power Input	11	(G)D2-			
	12	(R)+Vs			
	13	(B)GND			

Terminal No.	Pin Assignment	Terminal No.	Pin Assignment		
DO	01	DO			
DI	02	DI			
COM1	03	D1+	COM5	28 RxD5	
	04	D1-	27	TxD5	
	05	CTS1	26	RTS5	
	06	RTS1	25	CTS5	
	07	GND	24	GND	
	08	TxD1	COM4	23	RxD4
	09	RxD1		22	TxD4
	10	INIT*		21	RTS4
	COM2	11	(Y)D2+	20	CTS4
12		(G)D2-	19	GND	
Power Input	13	(R)+Vs	COM3	18	RxD3
	14	(B)GND		17	TxD3
				16	RTS3
			15	CTS3	

Terminal No.	Pin Assignment	Pin Assignment	Terminal No.	Pin Assignment	
COM3	01	CTS3	<p>COM1: RS-232 Male DB-9 Connector</p>	09	Data-
	02	RTS3		04	08 RTS
	03	RxD3		03	07 CTS
	04	TxD3		02	06 N.C.
	05	GND		01	
COM4	06	TxD4			
DI	07	RxD4			
	08	DI2			
COM2	09	INIT*			
	10	(Y)D2+			
Power Input	11	(G)D2-			
	12	(R)+Vs			
	13	(B)GND			

Terminal No.	Pin Assignment	Terminal No.	Pin Assignment		
DO	01	DO			
DI	02	DI			
COM1	03	D1+	COM7/8	28 TxD8	
	04	D1-	27	RxD8	
	05	CTS1	26	TxD7	
	06	RTS1	25	RxD7	
	07	GND	24	GND	
	08	TxD1	COM5/6	23	TxD6
	09	RxD1		22	RxD6
	10	INIT*		21	TxD5
	COM2	11	(Y)D2+	20	RxD5
12		(G)D2-	19	GND	
Power Input	13	(R)+Vs	COM3/4	18	TxD4
	14	(B)GND		17	RxD4
				16	TxD3
			15	RxD3	

Wiring

3-wire RS-232 Wiring

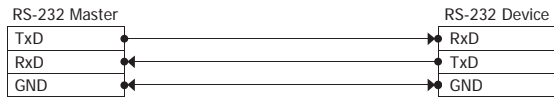

2-wire RS-485 Wiring

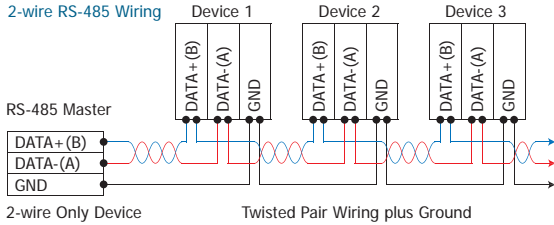

4-wire RS-422 Wiring

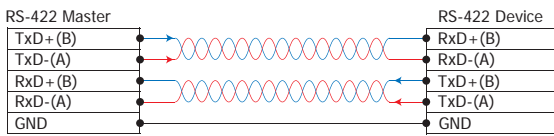

Input Type	DI Value as 0	DI Value as 1
Relay Contact	Relay ON 	Relay Off
	Voltage < 1V 	Voltage > 3.5V
Open Collector	Open Collector On 	Open Collector Off

Output Type	DO Command as 1	DO Command as 0
Drive Relay	Relay ON 	Relay Off
	Resistance Load 	Resistance Load

Dimensions (Unit: mm)

I-7521(D)/I-7522(D)/I-7523(D)

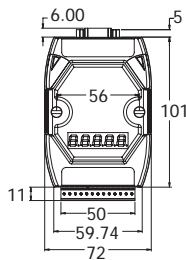

Front View

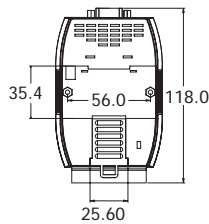

Rear View

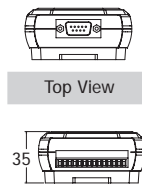

Top View

Bottom View



DIN-Rail Mounting Bracket

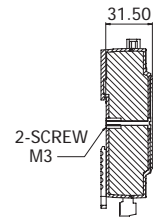

Side View

I-7521(D)/I-7522(D)/I-7523(D)

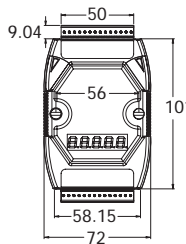

Front View

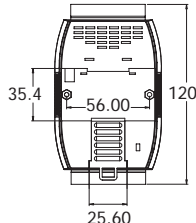

Rear View

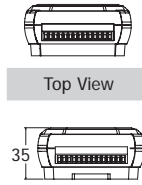

Top View

Bottom View



DIN-Rail Mounting Bracket

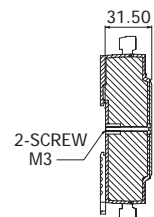

Side View

Ordering Information

I-7521 CR	Programmable Intelligent Communication Controller (RoHS)	I-7523 CR	Programmable Intelligent Communication Controller (RoHS)
I-7521D CR	I-7521 with Display	I-7523D CR	I-7523 with Display
I-7522 CR	Programmable Intelligent Communication Controller (RoHS)	I-7524 CR	Programmable Intelligent Communication Controller (RoHS)
I-7522D CR	I-7522 with Display	I-7524D CR	I-7524 with Display
I-7522A CR	Programmable Intelligent Communication Controller (RoHS)	I-7527 CR	Programmable Intelligent Communication Controller (RoHS)
I-7522AD CR	I-7522A with Display	I-7527D CR	I-7527 with Display

Accessories

MDR-20-24	24 Vdc/1 A, 24 W Power Supply with DIN-Rail Mounting	GPSU06U-6	24 Vdc/0.25 A, 6 W Power Supply
DIN-KA52F	24 Vdc/1.04 A, 25 W Power Supply with DIN-Rail Mounting	KA-52F	24 Vdc/1.04 A, 25 W Power Supply

tM-752N Series **NEW**

Tiny Addressable Serial Converter



Features ▶▶▶▶

- Integrates any RS-232 serial device
- 10/100 Base-TX Ethernet, RJ-45 x 1 (Auto-negotiating, auto MDI/MDIX, LED Indicators)
- Includes a UDP responder for device discovery
- Provides an intuitive web configuration interface
- Tiny form-factor and low power consumption
- Made from fire-retardant materials (UL94-V0 Level)
- Contains a high-performance 32-bit MCU
- Includes redundant power inputs: PoE and DC jack
- Provides automatic RS-485 direction control
- Supports easy firmware updates via the Ethernet
- Terminal block connector for easy wiring
- RoHS compliant & no Halogen
- Low channel count & cost-effective

Introduction

There are many RS-232 devices that are used in industrial applications. Nowadays, it has become important to link all these RS-232 devices together for automation purposes and for extracting information. Usually, those RS-232 devices are at a distance from the host PC and may be widely distributed throughout the factory. The tM-752N can be used to link multiple distributed RS-232 devices using a single RS-485 network. The RS-485 is renowned for its easy maintenance, simple cabling, stability, reliability and low cost. tM-752N is non-programmable and cost-effective module, while the I-752N is programmable.

Easy Configuration (DCON & Web)

The tM-752N series supports the DCON protocol (compatible with I-752N series), allowing users to modify the settings of the module, such as the serial port configuration and the operation mode, etc. The module also has a built-in web server which provides an intuitive web management interface that simplifies the configuration of the module.

Onboard 1 KB Queue buffer

The tM-752N series module is equipped with a 1 KB queue buffer for its local RS-232 device. All data can be stored in the queue buffer until the host PC has time to read it. This feature allows the host PC to link many low-speed RS-232 devices without suffering any data loss, and also makes it easier for baud rate converter applications to be implemented.

Self-Tuner ASIC inside

The built-in Self-Tuner ASIC on an RS-485 port can automatically detect and control the send/receive direction of the RS-485 network. Consequently, there is no need for application programs to be concerned with direction control of the RS-485 network.

Addressable RS-232 to RS-485 Converter

Most RS-232 devices don't support device addressing. The ICP DAS tM-752N series module assigns a unique address for each RS-232 device installed. When a command with a device address is sent to the RS-485 network, the destination tM-752N module removes the address field, and then passes the commands to the specified local RS-232 device. The response from the local RS-232 device will be returned to the host PC via the tM-752N.

Applications

- Factory Automation
- Building Automation
- Home Automation

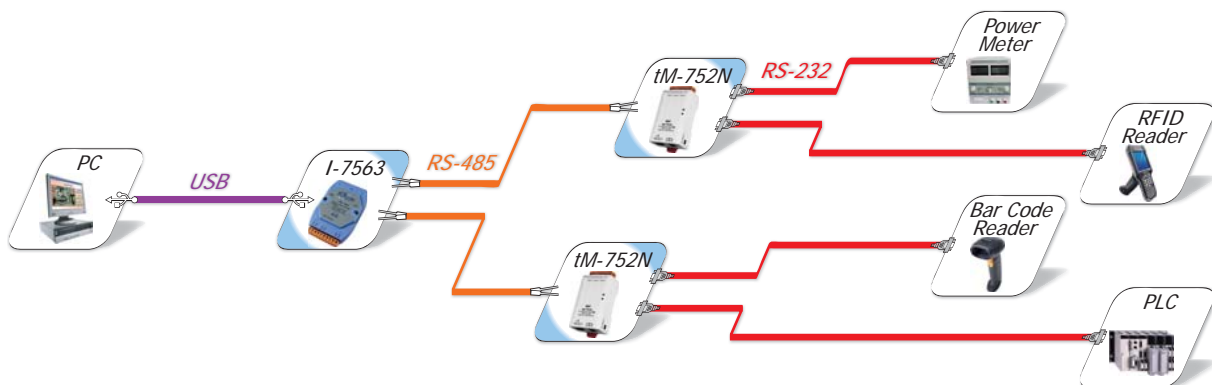

System Specifications

Models	tM-7521	tM-7522
System		
CPU	32-bit MCU	
Communication Interface		
Ethernet	10/100 Base-TX, 8-pin RJ-45 x 1 (Auto-negotiating, Auto-MDI/MDIX, LED indicator), PoE (IEEE 802.3af, Class 1)	
COM1	2-wire RS-485	
COM2	5-wire RS-232	3-wire RS-232
COM3	–	3-wire RS-232
Self-Tuner	Yes, automatic RS-485 direction control	
UART	16C550 or compatible	
COM Port Format		
Baud Rate	115200 bps Max.	
Data Bit	5, 6, 7, 8	
Parity	None, Odd, Even, Mark, Space	
Stop Bit	1, 2	
Connector	10-Pin Removable Terminal Block x 1	
Power		
Power Input	PoE	IEEE 802.3af, Class 1
	DC Jack	+12 ~ 48 V _{DC}
Power Consumption	0.05 A @ 24 V _{DC}	
Mechanical		
Casing	Plastic	
Flammability	Fire-Retardant Materials (UL94-V0 Level)	
Dimensions (W x H x D)	52 mm x 95 mm x 27 mm	
Installation	DIN-Rail Mounting	
Environment		
Operating Temperature	-25 °C ~ +75 °C	
Storage Temperature	-30 °C ~ +80 °C	
Humidity	0 ~ 90% RH, non-condensing	
Note: 5-Wire RS-232: RxD, TxD, CTS, RTS, GND (Non-isolated) 3-Wire RS-232: RxD, TxD, GND (Non-isolated) 2-Wire RS-485: DATA+, DATA-, GND (Non-isolated)		

Dimensions (Unit: mm)

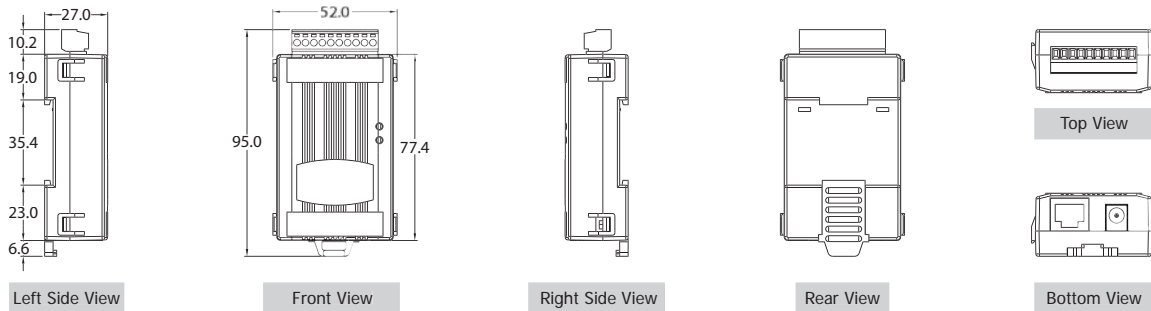

Ordering Information

tM-7521 CR	Tiny addressable serial converter, PoE and 1 RS-232 Port and 1 RS-485 Port (RoHS)
tM-7522 CR	Tiny addressable serial converter, PoE and 2 RS-232 Ports and 1 RS-485 Port (RoHS)
Includes: One CA-002 cable.	

Accessories

CA-002	DC connector to 2-wire power cable, 0.3 M
CA-0915	9-Pin Male-Female D-Sub Cable, 1.5 m
CA-0910F	Female DB-9 to Female DB-9 Cable, 1.0 m
CA-0910N	DB-9 Female-Female 3-wire Null Modem Cable, 1M
CA-PC09F	DB-9 Female connector with plastic cover
NS-205 CR	Unmanaged 5-port Industrial Ethernet Switch (RoHS)
NS-205PSE CR	Unmanaged Ethernet Switch with 4 PoE Ports and 1 RJ-45 Uplink (RoHS)

4.6. USB to RS-232/422/485 Converters

USB-2512 *Available soon*

USB to 2-Port RS-232 Converter

USB-2514 *Available soon*

USB to 4-Port RS-232 Converter

USB-4518 *Available soon*

USB to 8-Port RS-232 Converter



USB-2512

USB-2514

USB-4518



Features ▶▶▶

- Hi-Speed USB 2.0 for up to 480 Mbps USB transmission
- Power and data flow indicator for troubleshooting
- Transmission speed up to 921.6 kbps
- Driver Supports Windows 98/ME/2000/XP/Vista (32/64-bit)/7 (32/64-bit)/Linux
- Bus-powered; no need for external power supply for USB-2412/2514
- Operating Temperatures, -25 °C ~ +75 °C
- Lockable USB cable
- DIN-Rail Mounting

Introduction

USB-2512/2514 allows PC users to connect a serial device to a system that use a USB interface. To attach the USB-2512/2514 to a PC, you don't need to open the chassis or power down your PC. Instantly get extra high-speed RS-232 ports. The power is derived from the USB port, so there are no power adapters to deal with. Supporting high-speed 921.6 kbps transmission.

System Specifications

Models	USB-2512	USB-2514	USB-4518
Interface			
USB	Compatibility: USB 1.1 and 2.0 standards		
RS-232	TxD, RxD, RTS, CTS, DTR, DSR, DCD, RI, GND		
Speed	300 bps ~ 921.6 Kbps		
Connector	RS-232	DB9 male x 2	DB9 male x 4
	USB	Type B	
LED Indicators			
Power/Communication	Yes		
Power			
Input Voltage Range	Bus-powered		Bus-powered/External power supply
Power Consumption	0.2 W	4 W	8 W
Mechanical			
Casing	Plastic		
Flammability	Fire-Retardant Materials (UL94-V0 Level)		
Dimensions (W x H x D)	34 mm x 110 mm x 92 mm	31 mm x 157 mm x 116 mm	60 mm x 172 mm x 143 mm
Environment			
Operating Temperature	-25 °C ~ +75 °C		
Storage Temperature	-30 °C ~ +75 °C		
Humidity	10 ~ 90% RH, non-condensing		

Lockable USB Cable

The USB-2512/2514/4518 is designed for industrial applications in harsh environments. Lockable USB cable design ensure tight, robust connections, and guarantee reliable operation, even for applications that are subject to high vibration and shock.

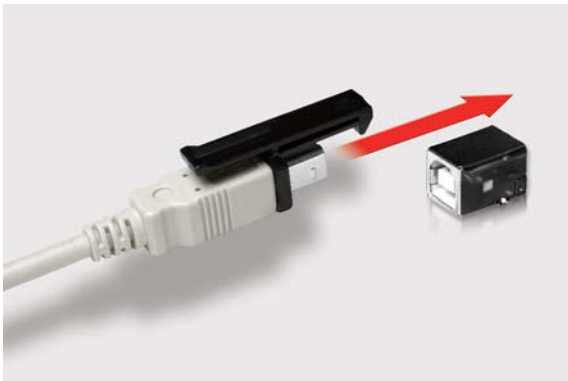

Applications

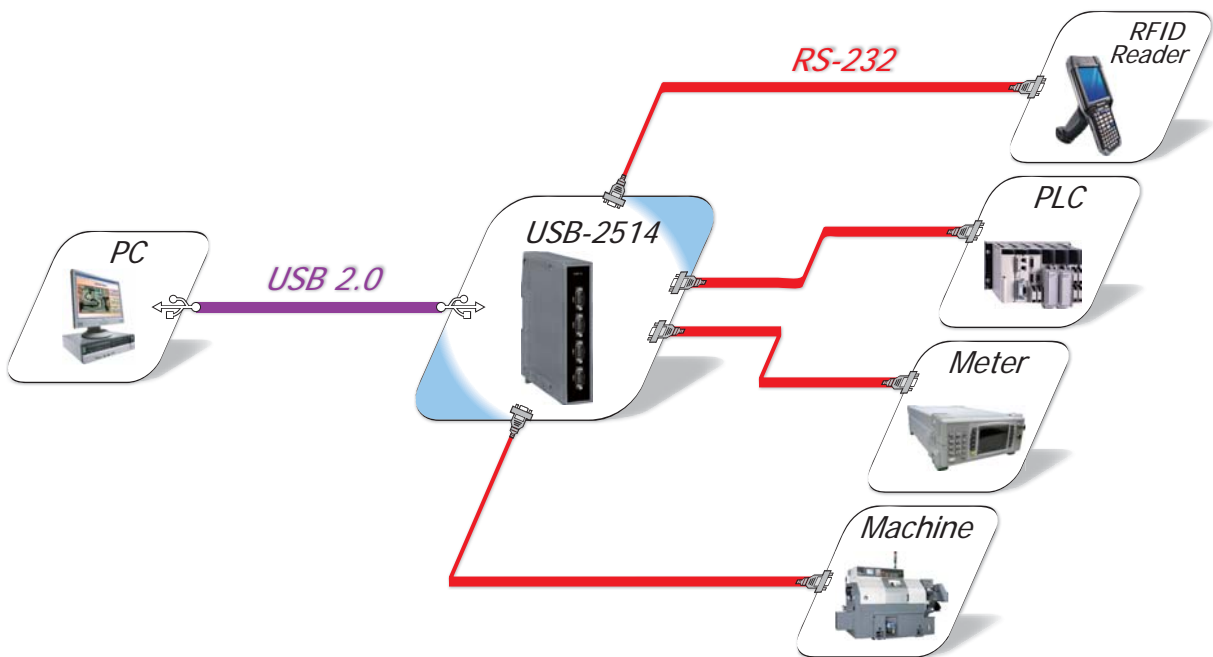

Ordering Information

USB-2512 CR	USB to 2-Port RS-232 Converter (RoHS)
USB-2514 CR	USB to 4-Port RS-232 Converter (RoHS)
USB-4518 CR	USB to 8-Port RS-232 Converter (RoHS)
Include Cable	CA-USB15 (1.5 m Cable) x 1

Accessories

USB-2560 CR	Industrial 4-port USB 2.0 Hub
-------------	-------------------------------

I-7560

USB to RS-232 Converter



Features ▶▶▶

- Fully Compliant with the USB 1.1/2.0 (High Speed)
- Driver Supports Windows 98/ME/2000/XP/Vista 7 (32/64-bit)/Linux
- No External Power Supply required
- Operating Temperatures, -25 °C ~ +75 °C

Introduction

The I-7560 provides a Windows serial COM port via its USB connection and is compatible with new and legacy RS-232 devices. USB Plug-and-Play allows easy serial port expansion and requires no IRQ, DMA, or I/O port settings manually.

The I-7560 features a full set of RS-232 modem data and control signals (TxD, RxD, RTS, CTS, DSR, DTR, DCD, RI and GND) on its PC compatible DB-9 male connector. It also features a high-speed 115200 bps transmission rate.

The I-7560 is powered from the USB bus and no additional power supply is needed.

Software

Driver	Windows 98/ME/2000/XP/Vista (32/64-bit)/7 (32/64-bit)/Linux
--------	---

System Specifications

Interface		
USB	Compatibility: USB 1.1 and 2.0 standards	
RS-232	TxD, RxD, RTS, CTS, DSR, DTR, DCD, RI and GND; non-isolated	
Speed	300 ~ 115200 bps	
Connector	RS-232	9-Pin Male D-Sub
	USB	Type B
Cable Included	CA-USB18 (1.8 m Cable) x 1	
LED Indicators		
Power	Yes	
Power		
Input Voltage Range	+5 V _{bc} from USB	
Power Consumption	0.3 W	
Mechanical		
Casing	Plastic	
Flammability	Fire-Retardant Materials (UL94-V0 Level)	
Dimensions (W x H x D)	33 mm x 60 mm x 15 mm	
Environment		
Operating Temperature	-25 °C ~ +75 °C	
Storage Temperature	-30 °C ~ +75 °C	
Humidity	10 ~ 90% RH, non-condensing	

Applications

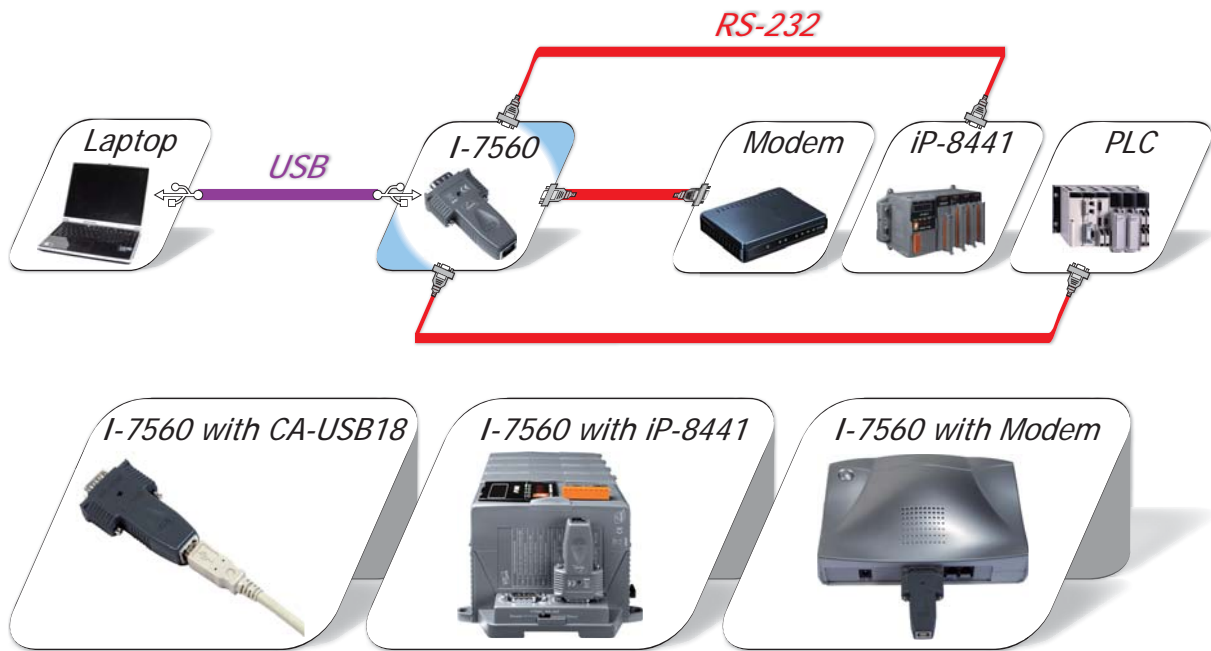

Pin Assignments

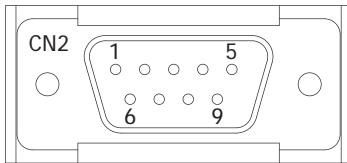

Pin	Signal	Mode
01	DCD Data Carrier Detect	Input
02	RxD Receive Data	Input
03	TxD Transmit Data	Output
04	DTR Data Term Ready	Output
05	GND Ground	--
06	DSR Data Set Ready	Input
07	RTS Request To Send	Output
08	CTS Clear To Send	Input
09	RI Ring Indicator	Input

Internal I/O Structure

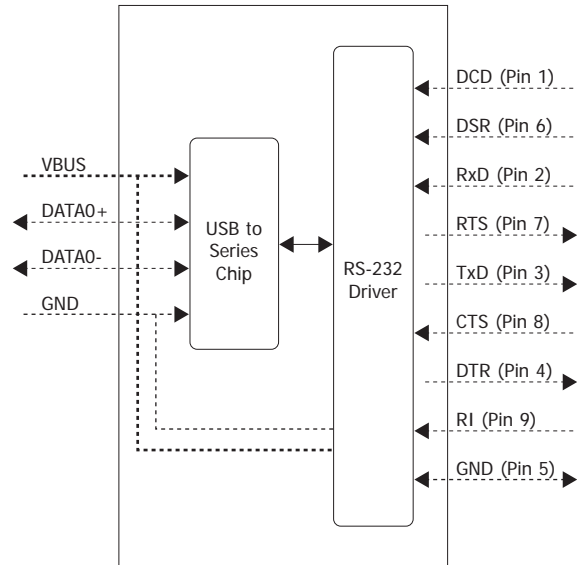

Dimensions (Unit: mm)

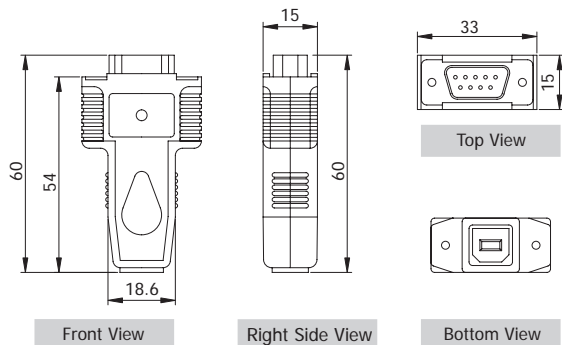

Ordering Information

I-7560 CR	USB to RS-232 Converter (RoHS)
-----------	--------------------------------

Accessories

USB-2560 CR	Industrial 4-port USB 2.0 Hub
CA-USB18	USB Type A to Type B Cable

tM-7561

USB to Isolated RS-485 Converter



Features ▶▶▶

- Fully Compliant with the USB 1.1/2.0 (High Speed)
- Power and data flow indicator for troubleshooting
- 2500 V_{DC} Isolation Protection on the RS-485 side
- Driver Supports Windows 98/ME/2000/XP/Vista (32/64-bit)/7 (32/64-bit)/Linux
- Tiny packaging fits on your DIN-Rail Mounting
- No External Power Supply required
- Automatic RS-485 Direction Control
- Operating Temperatures, -25 °C ~ +75 °C
- Low power consumption
- Cost-effective Converter

Introduction

The tM-7561 is a cost-effective USB to RS-485 converter. Connecting the tM-7561 to a PC, you get one RS-485 port that allows you to access RS-485 devices through the USB interface. Like the I-7520, the tM-7561 contains "Self-Tuner" chip auto-tunes the baud rate and data format to the RS-485 network. The tM-7561 module derives its power from the USB port and doesn't need external power adapter.

Comparison Table of Converter

Mode name	tM-7561	I-7561
Serial Interface	Only RS-485	RS-232/422/485
Dimensions (W x H x D)	52 mm x 87 mm x 27 mm	72 mm x 115 mm x 35 mm
Remarks	Cost-effective, Entry-level	Entry-level

Software

Driver	Windows 98/ME/2000/XP/Vista (32/64-bit)/7 (32/64-bit)/Linux
--------	---

System Specifications

Interface		
USB	Compatibility: USB 1.1 and 2.0 standards	
RS-485	Data+, Data-	
RS-485 Transmission Distance	Max. 1,200 m at 9.6 kbps; Max. 400 m at 115.2 kbps (Belden 9841 2P twisted-pair cable, if different cables are used, the transmission distance may change)	
Self-Tuner Asic Inside	Yes	
Speed	300 ~ 115200 bps	
Connector	RS-485	Removable 7-Pin Terminal Block
	USB	Type B
Cable Included	CA-USB18 (1.8 m Cable) x 1	
LED Indicators		
Power	Yes	
Power		
Input Voltage Range	+5 V _{DC} from USB	
Power Consumption	0.4 W	
Mechanical		
Casing	Plastic	
Flammability	Fire-Retardant Materials (UL94-V0 Level)	
Dimensions (W x H x D)	52 mm x 87 mm x 27 mm	
Installation	DIN-Rail Mounting	
Environment		
Operating Temperature	-25 °C ~ +75 °C	
Storage Temperature	-30 °C ~ +75 °C	
Humidity	10 ~ 90% RH, non-condensing	

Applications

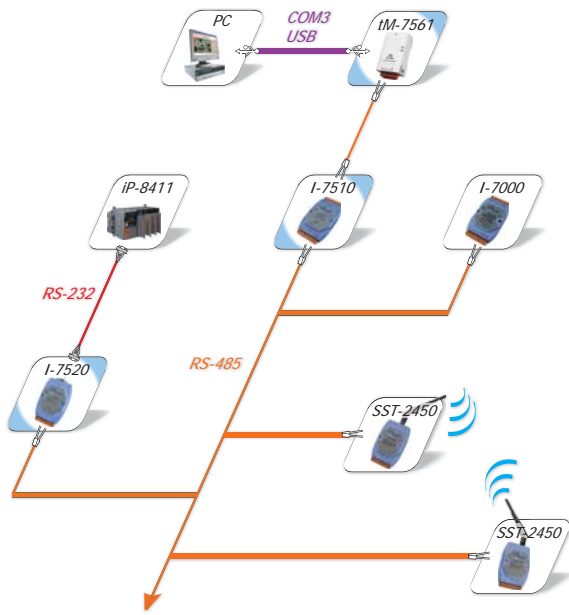

Internal I/O Structure

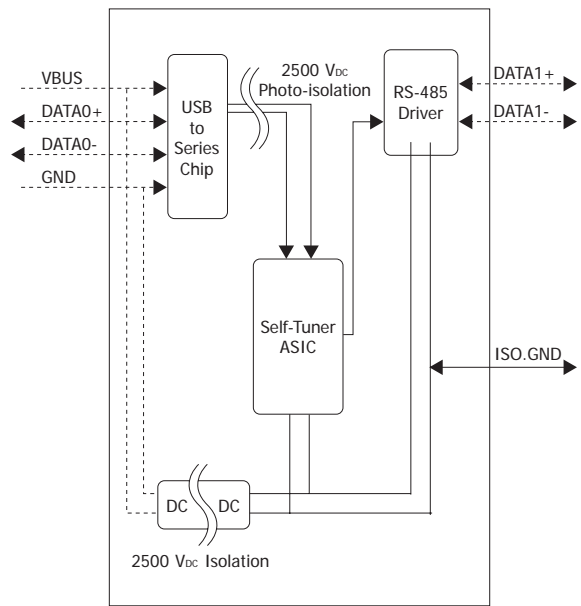

Pin Assignments

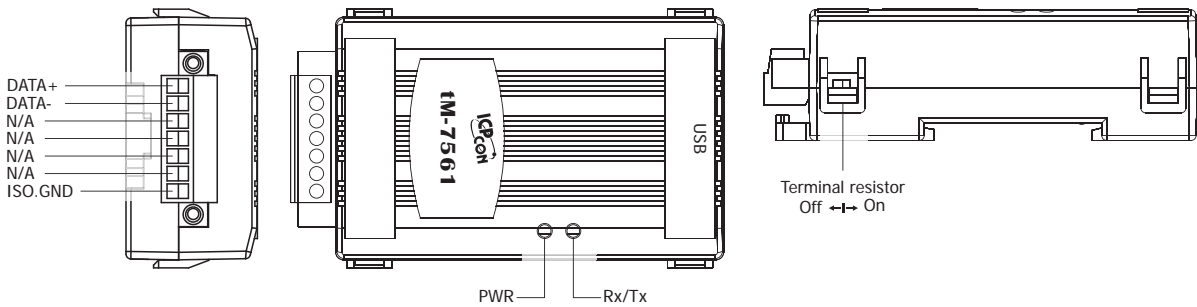

Dimensions (Unit: mm)

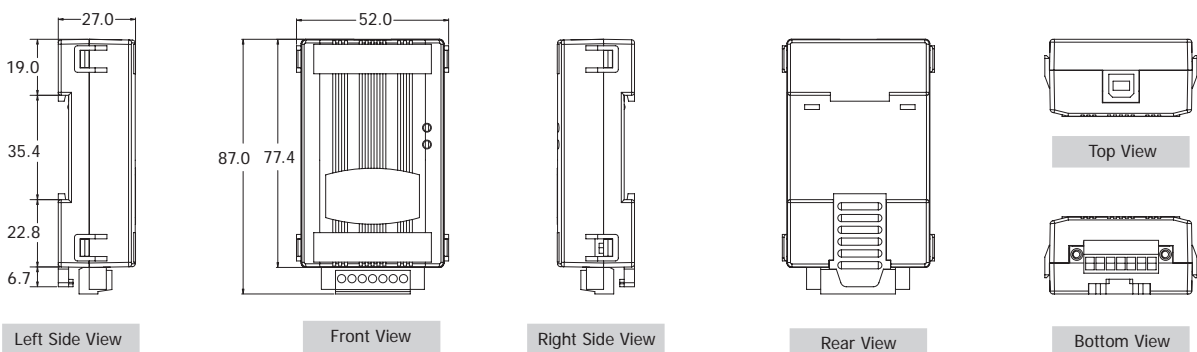

Ordering Information

tM-7561 CR	USB to Isolated RS-485 Converter (RoHS)
Include Cable	CA-USB18 (1.8 m Cable) x 1

Accessories

USB-2560 CR	Industrial 4-port USB 2.0 Hub
CA-USB18	USB Type A to Type B Cable

I-7561

USB to Isolated RS-232/422/485 Converter



I-7561

I-7561-G



Features ▶▶▶

- Fully Compliant with the USB 1.1/2.0 (High Speed)
- 3000 V_{DC} Isolation Protection on the RS-232/422/485 side
- ESD Protection for the RS-232/422/485 Data Line
- Driver Supports Windows 98/ME/2000/XP/Vista (32/64-bit)/7 (32/64-bit)/Linux
- No External Power Supply required
- Automatic RS-485 Direction Control
- Operating Temperatures, -25 °C ~ +75 °C
- DIN-Rail Mounting

Introduction

The I-7561 is a cost-effective module for transferring serial data via USB. It allows you to connect your serial devices to systems that use a USB interface. Connecting the I-7561 to a PC, you get one RS-232/422/485 port. Like the I-7520A, the I-7561 contains "Self-Tuner" chip auto-tunes the Baud Rate and data format to the RS-485 network. The I-7561 module derives its power from the USB port and doesn't need any power adapter.

Software

Driver	Windows 98/ME/2000/XP/Vista (32/64-bit)/7 (32/64-bit)/Linux
--------	---

System Specifications

Interface			
USB		Compatibility: USB 1.1 and 2.0 standards	
Serial Interface	RS-232	TxD, RxD, GND	The RS-232, RS-422 and RS-485 cannot be used simultaneously
	RS-422	TxD+, TxD-, RxD+, RxD-	
	RS-485	Data+, Data-	
RS-422/485 Transmission Distance		Max. 1,200 m at 9.6 kbps; Max. 400 m at 115.2 kbps (Belden 9841 2P twisted-pair cable, if different cables are used, the transmission distance may change)	
Self-Tuner Asic Inside (RS-485)		Yes	
Speed		300 ~ 115200 bps	
Connector	RS-232/422/485	Removable 10-Pin Terminal Block	
	USB	Type B	
Cable Included		CA-USB18 (1.8 m Cable) x 1	
LED Indicators			
Power		Yes	
Power			
Input Voltage Range		+5 V _{DC} from USB	
Power Consumption		0.5 W	
Mechanical			
Casing		Plastic	
Flammability		Fire-Retardant Materials (UL94-V0 Level)	
Dimensions (W x H x D)		72 mm x 115 mm x 35 mm	
Installation		DIN-Rail Mounting	
Environment			
Operating Temperature		-25 °C ~ +75 °C	
Storage Temperature		-30 °C ~ +75 °C	
Humidity		10 ~ 90% RH, non-condensing	

Applications

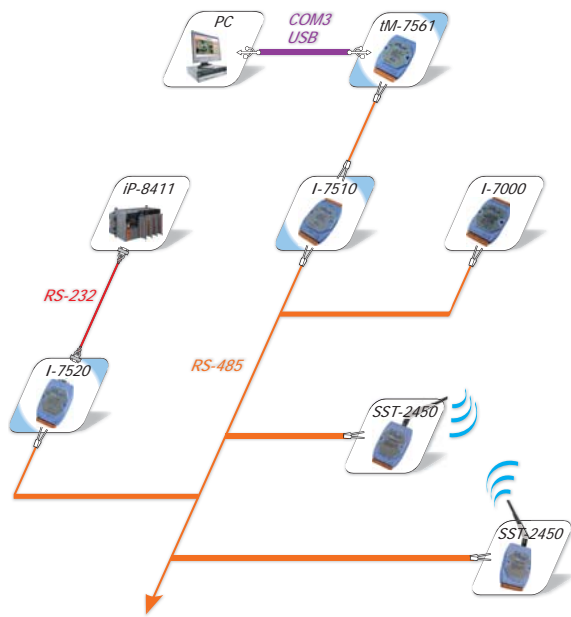

Internal I/O Structure

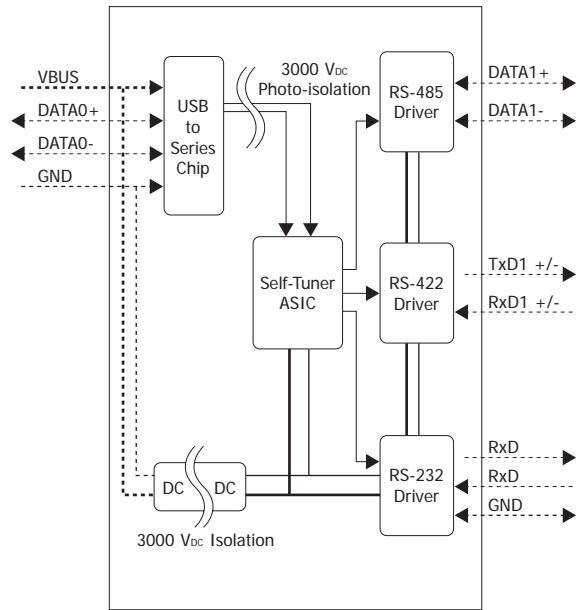

Dimensions (Unit: mm)

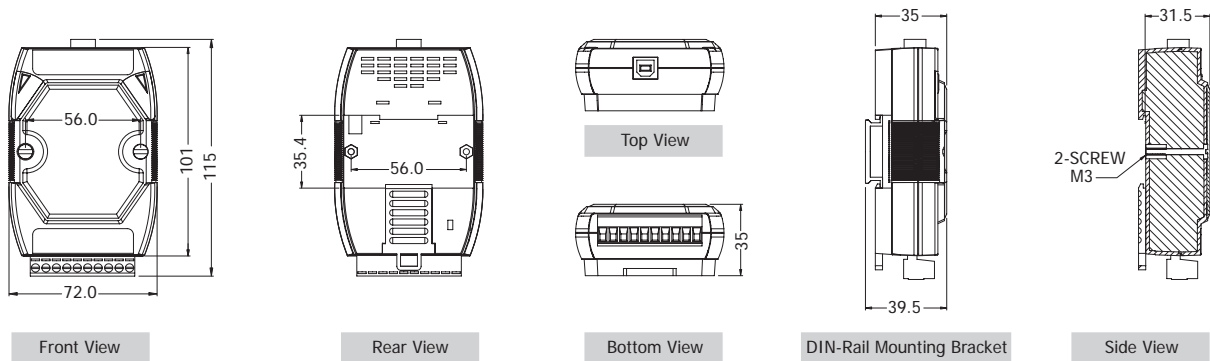

Pin Assignments



Terminal No.	Pin	Pin Assignment
RS-485	01	DATA+
	02	DATA-
RS-422/485	03	TxD+
	04	TxD-
	05	RxD+/DATA2+
	06	RxD-/DATA2-
RS-232	07	TxD
	08	RxD
	09	(B)GND
	10	(B)GND

Ordering Information

I-7561 CR	USB to Isolated RS-485 Converter (RoHS)
I-7561-G CR	USB to RS-232/422/485 Converter (Gray Cover) (RoHS)
Include Cable	CA-USB18 (1.8 m Cable) x 1

Accessories

USB-2560 CR	Industrial 4-port USB 2.0 Hub
CA-USB18	USB Type A to Type B Cable

I-7563

USB to Isolated RS-485 Active Star Wiring Converter



Features ▶▶▶▶

- Fully Compliant with the USB 1.1/2.0 (High Speed)
- RS-485 Active Star Wiring Applications
- 3000 V_{DC} Isolation Protection on the RS-485 side
- Driver Supports Windows 98/ME/2000/XP/Vista (32/64-bit)/7 (32/64-bit)/Linux
- No External Power Supply required
- Automatic RS-485 Direction Control
- ESD Protection for the RS-485 Data Line
- Operating Temperatures, -25 °C ~ +75 °C
- DIN-Rail Mounting

Introduction

The I-7563 is a cost-effective module for transferring serial data via USB. It allows you to connect your serial devices to systems that use a USB interface. Connecting the I-7563 to a PC, you get one COM port on system. The I-7563 contains "Self-Tuner", this chip auto-tunes the Baud Rate and data format to the RS-485 network. The I-7563 module derives its power from the USB port and doesn't need any power adapter.

Do you have any RS-485 wiring problems I-7563 is a USB to 1-channel RS-485 converter with a 3-way RS-485 Hub. Each channel contains its own RS-485 driver IC, so it can support star-shaped wiring.

System Specifications

Interface		
USB		Compatibility: USB 1.1 and 2.0 standards
RS-485		3 Channels: For active star wiring applications
		Data1+, Data1-
		Data2+, Data2-
RS-485 Transmission Distance		Max. 1,200 m at 9.6 kbps; Max. 400 m at 115.2 kbps (Belden 9841 2P twisted-pair cable, if different cables are used, the transmission distance may change)
Self-Tuner Asic Inside for RS-485		Yes
Speed		300 ~ 115200 bps
Connector	RS-485	Removable 10-Pin Terminal Block
	USB	Type B
Cable Included		CA-USB18 (1.8 m Cable) x 1
LED Indicators		
Power		Yes
Power		
Input Voltage Range		+5 V _{DC} from USB
Power Consumption		0.5 W
Mechanical		
Casing		Plastic
Flammability		Fire-Retardant Materials (UL94-V0 Level)
Dimensions (W x H x D)		72 mm x 115 mm x 35 mm
Installation		DIN-Rail Mounting
Environment		
Operating Temperature		-25 °C ~ +75 °C
Storage Temperature		-30 °C ~ +75 °C
Humidity		10 ~ 90% RH, non-condensing

Applications

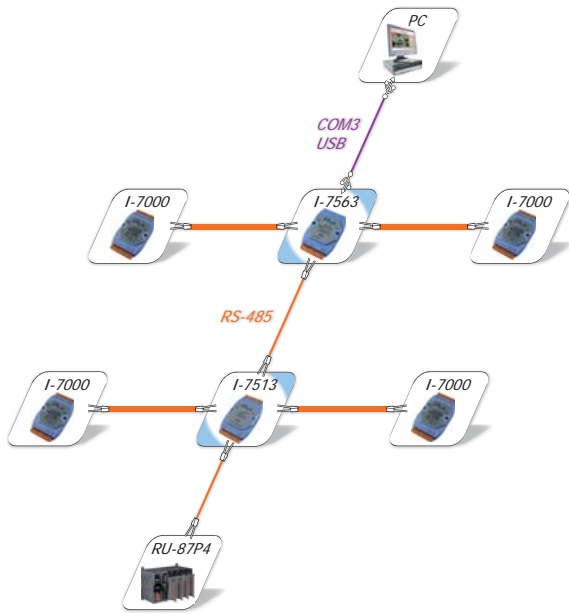

Internal I/O Structure

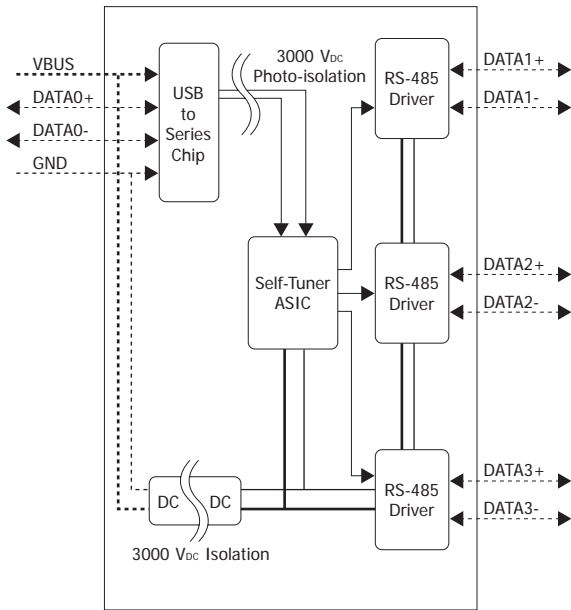

Dimensions (Unit: mm)

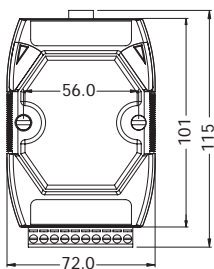

Front View

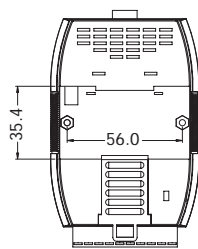

Rear View

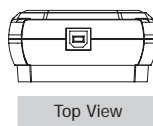

Top View

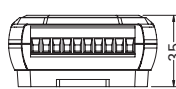

Bottom View

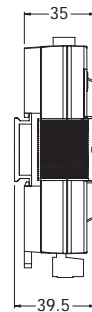

DIN-Rail Mounting Bracket

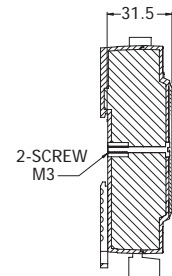

Side View

Pin Assignments



Terminal No.	Pin Assignment
RS-485	01 DATA3 +
	02 DATA3 -
	03 --
	04 --
RS-485	05 DATA2 -
	06 DATA2 +
	07 --
	08 --
RS-485	09 DATA1 -
	10 DATA1 +

Ordering Information

I-7563 CR	USB to Isolated RS-485 Active Star Wiring Converter (RoHS)
I-7563-G CR	USB to Isolated RS-485 Active Star Wiring Converter (Gray Cover) (RoHS)
Include Cable	CA-USB18 (1.8 m Cable) x 1

Accessories

USB-2560 CR	Industrial 4-port USB 2.0 Hub
CA-USB18	USB Type A to Type B Cable

4.7. RS-232/422/485 to Fiber Optic Converter

I-2541

RS-232/422/485 to Multi-Mode Fiber optic converter

I-2542 series *Available soon*

RS-232/422/485 to Single-Mode Fiber optic converter



Features ▶▶▶

- Automatic RS-485 Direction Control
- Avoids lightning strikes and EMI/RFI interference
- Supports +10 V_{DC} ~ +30 V_{DC}
- DIN-Rail Mounting
- Optical fibers enable transmission of 2 km for I-2541 and 15 km for I-2542-A/I-2542-B
- ESD Protection for the RS-232/422/485 Data Line
- Supports operating temperatures from -25 °C ~ +75 °C

Introduction

The I-2541 is an RS-232/422/485 to fiber optic converter that secures data transmission by using fiber optic transmission to provide immunity from EMI/RFI interference. The I-2541 is used for RS-232/422 point-to-point connections and RS-485 multi-drop applications for transmitting a signal up to 2 km and is the perfect solution for applications where transmission must be protected from electrical exposure, surges or chemical corrosion.

The I-2542 series of Single-Strand Fiber Converters supports Wavelength Division Multiplexing (WDM) technology that allows two independent data communication channels to transmit and receive over one standard, single mode, fiber optic line. This not only doubles your existing bandwidth, but also effectively reduces the cost of creating a new fiber optic infrastructure.

System Specifications

Models		I-2541	I-2542 series
Interface			
Fiber Interface	Fiber Port	Multi Mode; ST connector	Single-Mode; SC connector
	Wavelength	850 nm	TX: 1310, RX: 1550 nm for I-2542-A TX: 1550, RX: 1310 nm for I-2542-B
	Fiber Cable	50/125, 62.5/125, 100/140 μm	8.3/125, 8.7/125, 9/125 or 10/125 μm
	Distance	2 km, (62.5/125 μm recommended)	15 km, (9/125 μm recommended)
Serial Interface	RS-232	The RS-232, RS-422 and RS-485 cannot be used simultaneously	TxD, RxD, GND
	RS-422		TxD+, TxD-, RxD+, RxD-
	RS-485		Data+, Data-
RS-422/485 Transmission Distance		Max. 1,200 m at 9.6 kbps; Max. 400 m at 115.2 kbps (Belden 9841 2P twisted-pair cable, if different cables are used, the transmission distance may change)	
Self-Tuner Asic Inside		Yes	
Speed		300 ~ 115200 bps	4800 ~ 115200 bps
ESD Protection		Yes	
RS-232/422/485 Connector		Removable 8-Pin Terminal Block	
LED Indicators			
Power		Yes	
Power			
Input Voltage Range		+10 V _{DC} ~ +30 V _{DC} (Non-isolated)	
Power Consumption		1.5 W	2 W
Mechanical			
Casing		Plastic	
Flammability		Fire-Retardant Materials (UL94-V0 Level)	
Dimensions (W x L x H)		33 mm x 89 mm x 107 mm	
Installation		DIN-Rail Mounting	
Environment			
Operating Temperature		-25 °C ~ +75 °C	
Storage Temperature		-30 °C ~ +75 °C	
Humidity		10 ~ 90% RH, non-condensing	

Internal I/O Structure

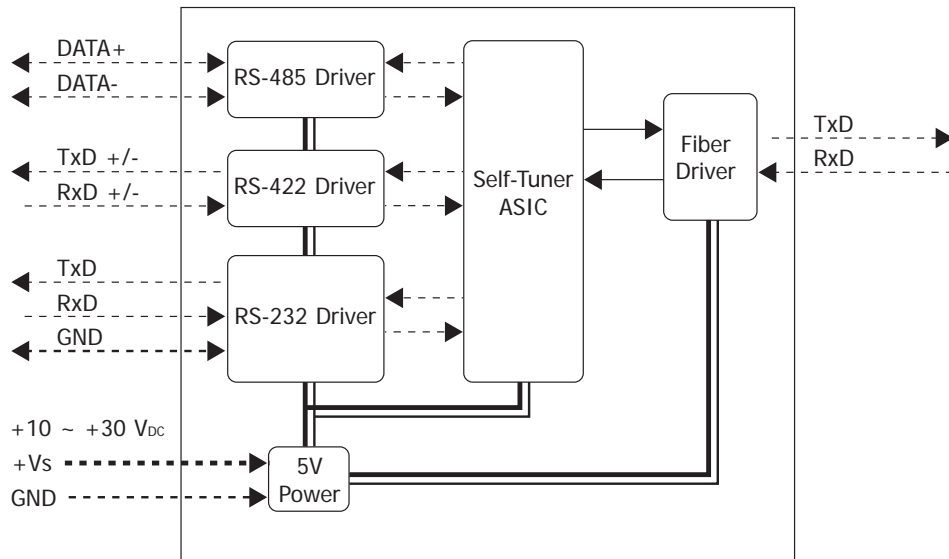

Dimensions (Unit: mm)

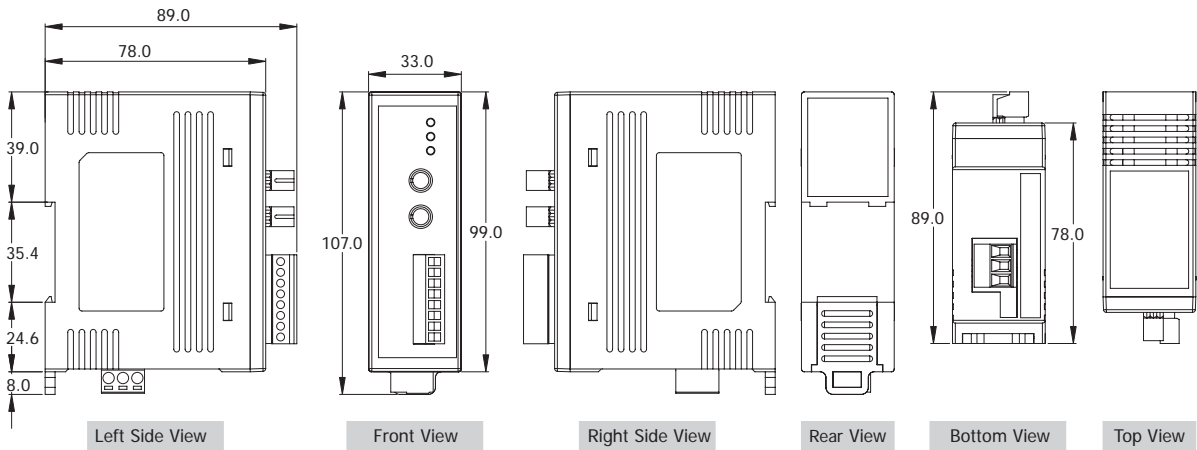

Pin Assignments

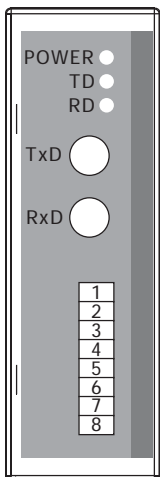

Terminal No.	Pin Assignment
TxD	Fiber TxD
RxD	Fiber RxD
01	TxD+/DATA+
02	TxD-/DATA-
03	RxD+
04	RxD-
05	NC
06	GND
07	TxD
08	RxD

Ordering Information

I-2541 CR	RS-232/422/485 to Multi-Mode 2 Km, ST Fiber optic converter
I-2542-A CR	RS-232/422/485 to Single-Mode 15 Km, SC Fiber optic converter, TX 1310 nm, RX 1550 nm (RoHS)
I-2542-B CR	RS-232/422/485 to Single-Mode 15 Km, SC Fiber optic converter, TX 1550 nm, RX 1310 nm (RoHS)

Important Note:
You must purchase both I-2542-A and I-2542-B since these products work as a pair.

Accessories

GPSU06U-6	24 Vdc/0.25 A, 6 W Power Supply
DIN-KA52F	24 Vdc/1.04 A, 25 W Power Supply with DIN-Rail Mounting

Applications

An illustration of the I-2541/I-2542 for RS-485 Devices

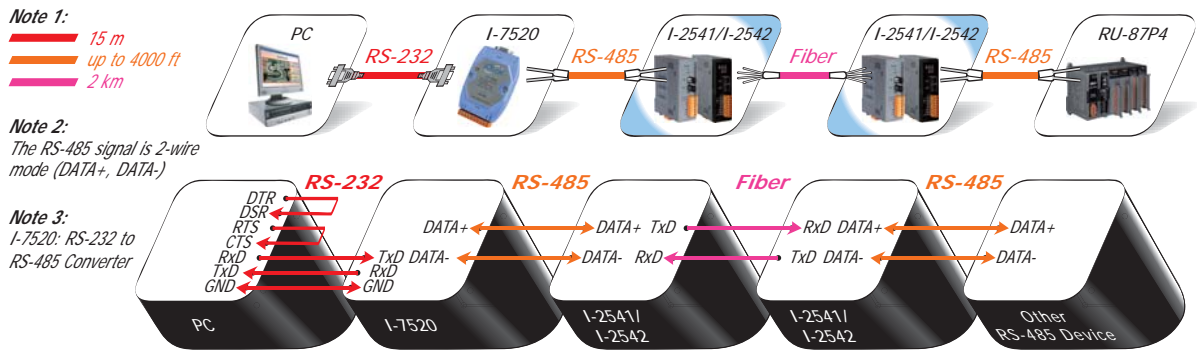

An illustration of the I-2541/I-2542 for RS-422 Devices

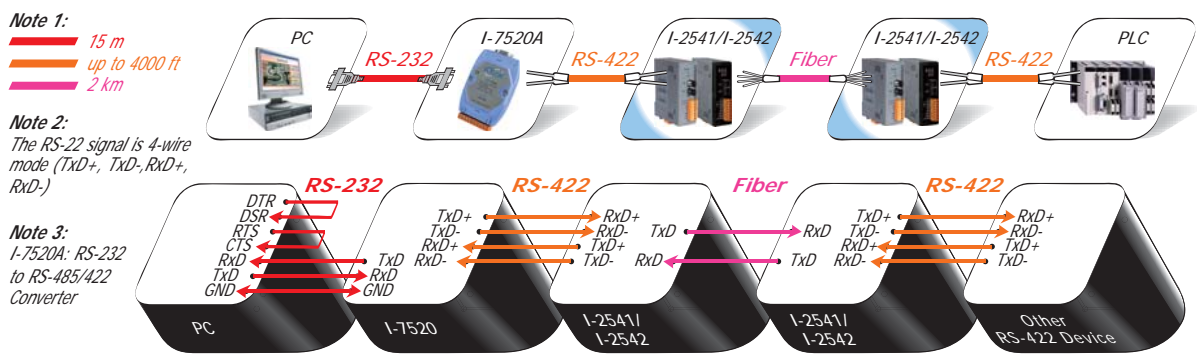

An illustration of the I-2541/I-2542 for RS-232 Devices

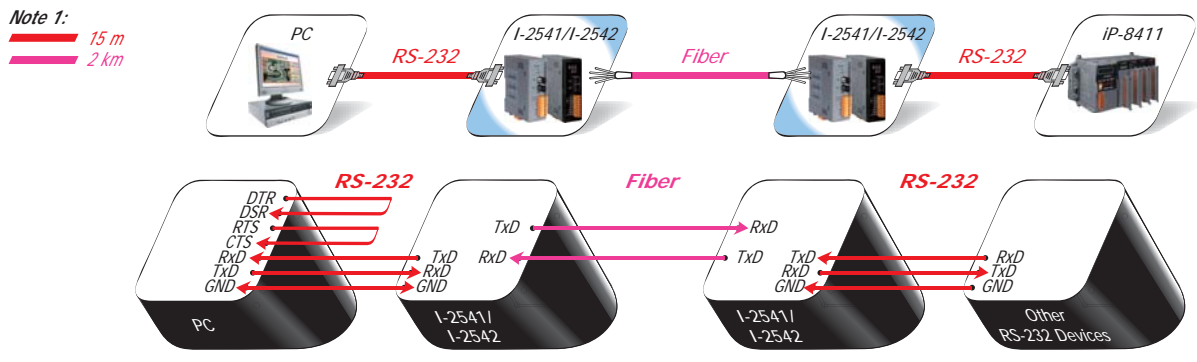

An illustration of the I-2541/I-2542 for RS-232/422/485 Devices

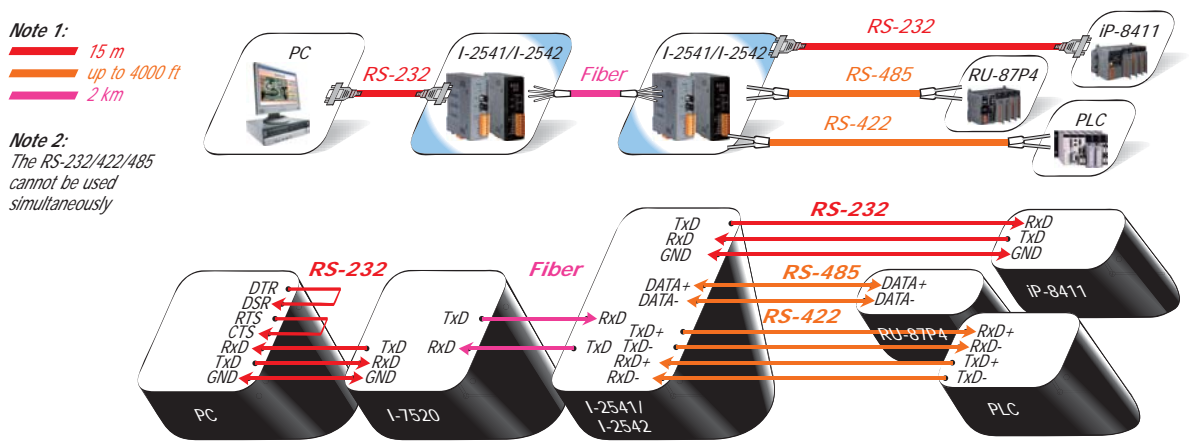

Fieldbus Solutions



5-1 Overview	5-1-1
5-2 CAN Bus Introduction & Products	5-2-1
5-3 CANopen Introduction & Products	5-3-1
5-4 DeviceNet Introduction & Products	5-4-1
5-5 J1939 Introduction & Products	5-5-1
5-6 PROFIBUS Introduction & Products	5-6-1
5-7 HART Introduction & Products	5-7-1
5-8 EtherNet/IP Introduction & Products	5-8-1
5-9 BACnet Introduction & Products	5-9-1

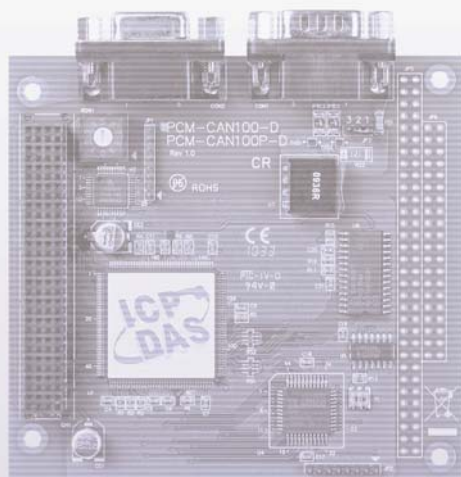

5-1 Overview

Fieldbus is an industrial network system for real-time distributed control. It is a way to connect instruments in a manufacturing plant. Fieldbus works on a network structure which typically allows daisy-chain, star, ring, branch, and tree network topologies. Fieldbus reduces both the length and the number of cables required. Fieldbus has many major advantages to all applications of automation. The technology of fieldbus is mature and well accepted in various fields in markets. ICP DAS has focused on these fieldbus products for several years and offers various fieldbus solutions in different industrial applications, covering the entire scope of process and manufacturing automation: CAN bus, CANopen, DeviceNet, J1939, PROFIBUS, HART, EtherNet/IP and BACnet applications.



5

1

Fieldbus Solutions

ICP DAS's Fieldbus Development Services group has been involved in the design and development of industrial fieldbus and industrial Ethernet products for several years. Besides providing the various fieldbus products, the rich experience and expertise helps the customer to arrange the proper system architecture and to solve the problems occurred during setting up a system. By using the certified IC and certification tool, all products are reliable and compatible with other manufacturers' products.

Solutions for Fieldbus and industrial Ethernet

In order to solve various communication problems in different fieldbus and industrial Ethernet applications, ICP DAS provides converters, gateways, PC based, and PAC based solutions of fieldbus and industrial Ethernet for users. Users can choose corresponding solutions depending on various field applications.



5-2 CAN Bus Introduction & Products

Introduction

ICP DAS has been developing various CAN products for several years, including PCI interface cards, converters, PACs and expansion modules. ICP DAS holds CAN conference, exhibition and training course all of the world. We also help customers to resolve various CAN technology problems. In addition, we can provide CAN bus solution for our customers.

CAN Bus Features

- Multi-master

When the CAN bus is free, any unit which wants to send a CAN message may start to transmit a message at the same time. Therefore, the multi-master architecture can be realized easily without message conflict. The unit with the message of highest priority to be transmitted gains bus access.

- Safety

In order to achieve the utmost safety of data transfer, powerful measures for error detection, signaling and self-checking are implemented in every CAN node.

- Priorities

The CAN IDENTIFIER defines a static message priority during bus access.

- Arbitration

If two or more nodes start transmitting messages at the same time, the arbitration mechanism is applied to guarantee that one of these messages can be sent successfully according to the priority.

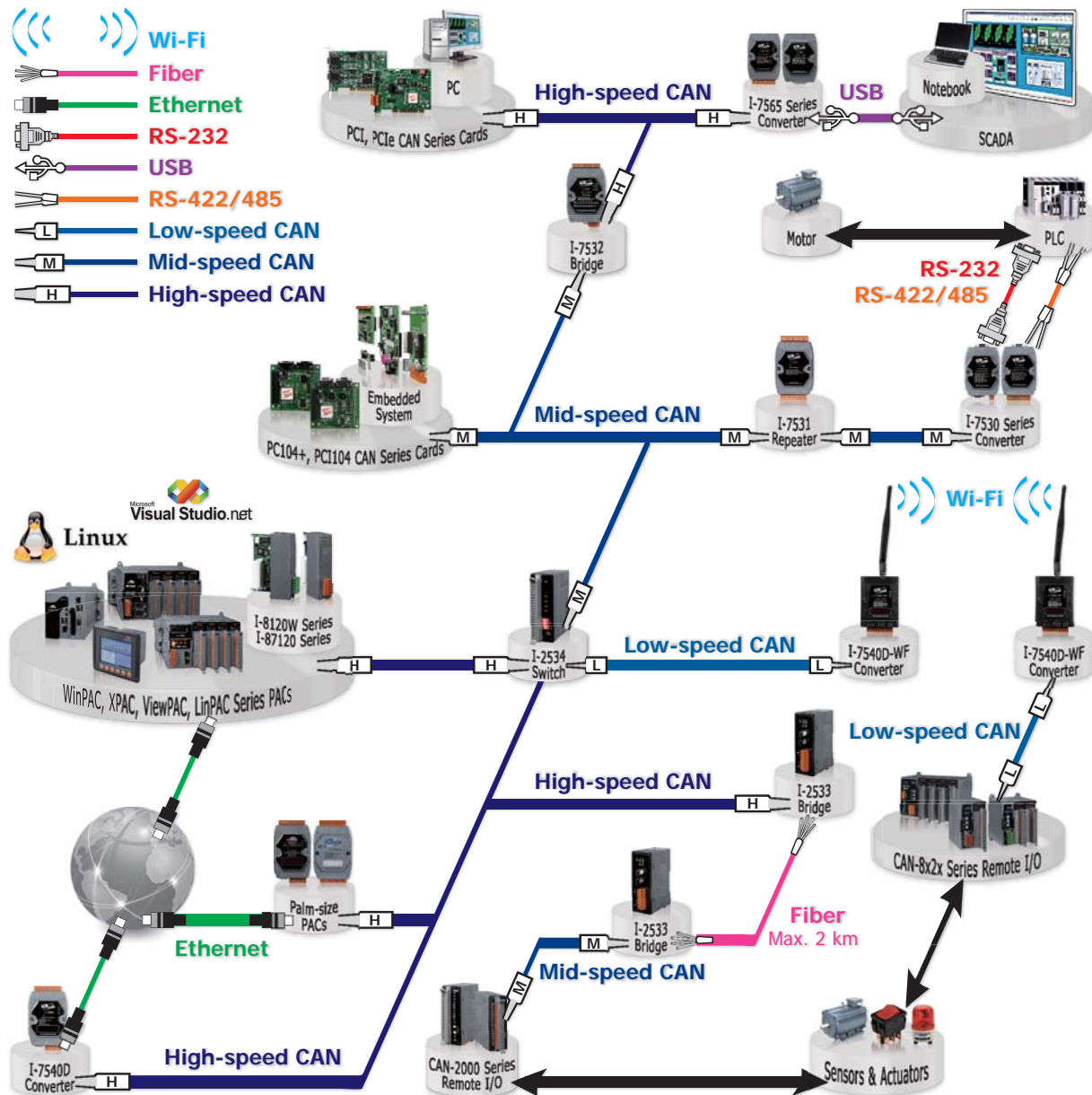

● Application Stories

▶▶▶▶ Concrete Station Monitor & Control System

Location: Hunan, China
Product: PISO-CM100U

The result of the quantity control of each recipe material seriously affects the quality of the concrete. In order to adjust each quantity promptly, CAN bus is applied. In this system, the PISO-CM100U is used to monitor the weight of each material from the load cells, and sends the recipe to the PLC. Meanwhile, the PC updates all the data to the screen. By using the user-defined firmware in the CPU of the PISO-CM100U, the PC loading can be effectively reduced, and the system becomes more smooth and reliable.

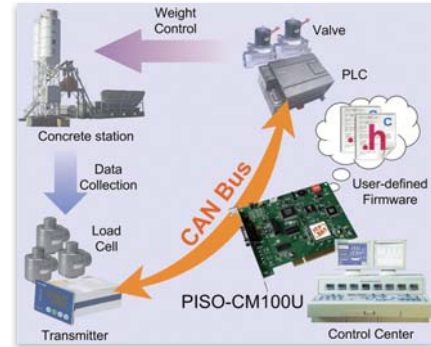

▶▶▶▶ Cash-in-transit Vehicle

Location: England, United Kingdom
Product: I-7530-FT

A telematics and vehicle control system need to be closely integrated with each other by some data-exchange interfaces. LSFT (Low-Speed/Fault-Tolerance) CAN is a kind of familiar interfaces in the applications of automotive electronics. An I-7530-FT is specially designed for solving the interface transformation between LSFT CAN and RS-232. Through it, the cash-in-transit of the manufacturer can control the door of the cash safely and monitor the conditions of the back door directly and reliably on the telematics.



▶▶▶▶ Tram Energy Recycle System

Location: Hyogo, Japan
Product: I-2533

Energy saving and carbon reduction has become what every country has to strive for. Therefore, the customer applies the regenerative braking to recycle the kinetic energy of the tram while it is braking. In order to resistant environment disturbances, extend CAN bus working distance and provide the higher CAN transmission speed, a couple of I-2533s are used. By means of them, the transmission distance of CAN bus is extended via 1 km fiber optics while using 500 kbps CAN baud rate.

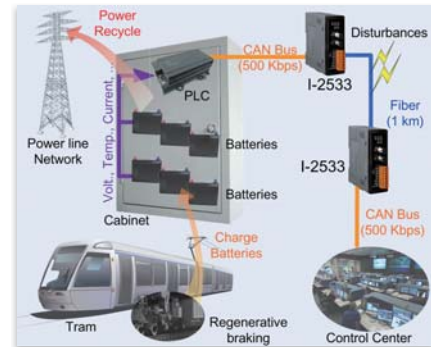

▶▶▶▶ Energy Storage System

Location: Guangdong, China
Product: I-8120W, I-8057W, VP-25W1, XP-8341

This system can improve the usage efficiency of the electrical power. During the off-peak time of the electricity use, the unused electricity can be stored in the battery. When the peak time is coming, these batteries supply the power to the electric grid. The customer utilizes one of the I-8120Ws in VP-25W1 to monitor the battery status, and another is used to feedback these data to the XP-8341. The XP-8341 transmits the status to the PC via Ethernet and control the charge time by the breaker.

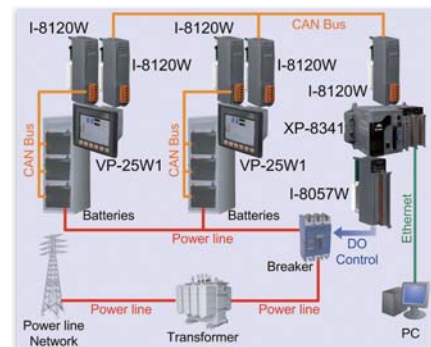

● Selection Guide

Model Name	CPU	Interface	Tools	Description	Page
CAN Bus Converters & Repeaters					
I-2532	–	CAN ↔ Fiber	–	CAN to fiber converter	5-2-4
I-2533				CAN to fiber bridge	
I-2534	–	CAN ↔ CAN x 3	–	Isolated 4-port CAN bus switch	5-2-5
I-7531		CAN ↔ CAN		Isolated CAN bus repeater	
I-7532				Isolated CAN bus bridge	
SG-770	–	CAN ↔ CAN	–	7-ch surge protector	5-2-6
I-7530	8-bit, 20 MHz	CAN ↔ RS-232	VC6, VB6, VS.Net	CAN to RS-232 converter	
I-7530-FT				Low-Speed/Fault-Tolerance CAN to RS-232 converter	
I-7530A	8-bit, 20 MHz	CAN ↔ RS-232/RS-422/ RS-485		CAN to RS-232/RS-422/RS-485 converter	
I-7530A-MR	32-bit, 96 MHz			CAN to Modbus RTU slave converter	
I-7540D	80186, 80 MHz	CAN ↔ Ethernet	VC6, VB6, VS.Net	CAN to Ethernet converter	
I-7540D-MTCP				CAN to Modbus TCP server converter	
I-7540D-WF	32-bit, 96 MHz	CAN ↔ Wi-Fi		CAN to Wi-Fi converter	
I-7565	8-bit, 20 MHz	CAN ↔ USB	VC6, VB6, VS.Net	USB to CAN converter	5-2-7
I-7565-H1	32-bit 72 MHz	CAN x 1 ↔ USB		High performance 1-port USB to CAN converter	
I-7565-H2		CAN x 2 ↔ USB		High performance 2-port USB to CAN converter	
CAN Bus μPACs					
I-7188XBD-CAN	80186, 40 MHz Built-in MiniOS7	RS-232 x 1 and RS-485 x 1 DI x 1 and DO x 1 CAN x 1	<ul style="list-style-type: none"> ■ Turbo C/C++ ■ Borland C/C++ ■ MiniOS7 Studio 	Standalone CAN/RS-232/RS-485 PAC	5-2-8
μPAC-7186EXD-CAN	80186, 80 MHz Built-in MiniOS7	RS-232 x 1 and RS-485 x 1 Ethernet port x 1 CAN x 1		Standalone Ethernet/CAN/RS-232/RS-485 PAC	
CAN Bus Modules					
I-8120W	80186, 80 MHz Built-in MiniOS7	Backplane parallel bus CAN x 1	Firmware Tools: <ul style="list-style-type: none"> ■ Turbo C/C++ ■ Borland C/C++ ■ MiniOS7 Studio MCU Tools: <ul style="list-style-type: none"> ■ eVC++, VS .NET 	Intelligent 1-port CAN I-8K module	5-2-8
I-87120		Backplane serial bus CAN x 1		Intelligent 1-port CAN I-87K module	
CAN Bus Boards					
PCM-CAN100	–	PCI-104, CAN x 1	VC6, VB6, VS.Net, OPC, ActiveX, RTX, DASYLab, LabVIEW	Isolated 1-port PCI-104 CAN board	5-2-9
PCM-CAN200		PCI-104, CAN x 2		Isolated 2-port PCI-104 CAN board	
PCM-CAN200P		PC/104-Plus, CAN x 2		Isolated 2-port PC/104-Plus CAN board	
PCM-CM100	80186, 80 MHz Built-in MiniOS7	PCI-104, CAN x 1	Firmware Tools: MiniOS7 Studio PC Tools: VC6, VB6, VS.NET	Intelligent 1-port PCI-104 CAN board	5-2-10
PEX-CAN200i	–	PCI-E x1, CAN x 2	VC6, VB6, VS.Net, OPC, ActiveX, RTX, DASYLab, LabVIEW	Isolated 2-port PCI-Express CAN board	
PISO-CAN100U	–	Universal PCI bus, CAN x 1	VC6, VB6, VS.Net, OPC, ActiveX, RTX, DASYLab, LabVIEW	Isolated 1-port universal PCI CAN board	
PISO-CAN200U		Universal PCI bus, CAN x 2		Isolated 2-port universal PCI CAN board	
PISO-CAN400U		Universal PCI bus, CAN x 4		Isolated 4-port universal PCI CAN board	
PISO-CAN800U		Universal PCI bus, CAN x 8		Isolated 8-port universal PCI CAN board	
PISO-CM100U	80186, 80 MHz Built-in MiniOS7	Universal PCI bus, CAN x 1	Firmware Tools: MiniOS7 Studio PC Tools: VC6, VB6, VS.NET	Intelligent 1-port universal PCI CAN board	
CAN Bus Power Meters					
PM-2133-CAN series	–	CAN x 1 RS-485 x 1 CT x 3	–	3-phase compact power meter	5-2-10
PM-2134-CAN series		CAN x 1 RS-485 x 1 CT x 4		4-loops 1-phase compact power meter	

• Product Showcase

✓ CAN Bus Converters & Repeaters

▶▶▶▶ CAN to Fiber Converter

I-2532 CR

I-2532 is a CAN to fiber optic converter that secures data transmission by using fiber optic transmission to provide immunity from EMS/RFI interference, which is designed to extend high CAN bus signals onto fiber optic cables.

- Compatible with CAN specification 2.0 parts A and B
- Support several kinds of baud rate from 10 kbps to 500 kbps
- 2500 V_{rms} photocoupler isolation on the CAN side
- DIP switch for 120 Ω terminator resistor of CAN bus
- Wave Length: 850 nm
- One CAN and one fiber channel
- Fully compatible with the ISO 11898-2 standard
- Watchdog inside
- 3 kV galvanic isolation
- Fiber Port: ST (Multi-mode)
- Fiber Cable: 62.5/125 μm
- Configure CAN Baud by rotary switch

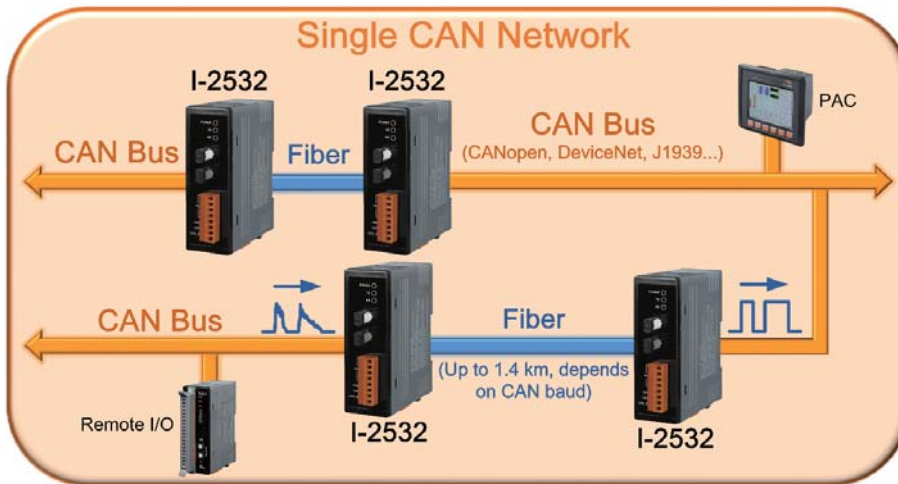

▶▶▶▶ CAN to Fiber Bridge

I-2533 CR *NEW*

I-2533 is a local CAN bridge used to establish a connection between two CAN bus system via fiber optic. By using I-2533, the transmission distance limitation of the CAN bus system will not reduced because of CAN baud rate. It means that the total network distance can be extended. This feature helps users' applications more powerful and flexible.

- Fiber Port: ST (Multi-mode)
- Fiber Cable: 62.5/125 μm
- 82C250 CAN transceiver
- 2500 V_{rms} iCoupler isolation on the CAN side
- Fully compatible with the ISO 11898-2 standard
- Up to 100 CAN nodes on each channel
- Allow user-defined baud rate
- Utility tool for message filter configuration
- Wave Length: 850 nm
- Maximum transmission distance up to 2 km at any CAN baud rate
- Support both CAN 2.0A and CAN 2.0B
- Built-in switch for 120 Ω terminator resistor
- Rotary switch for CAN baud rate configuration
- Fiber broken line detection

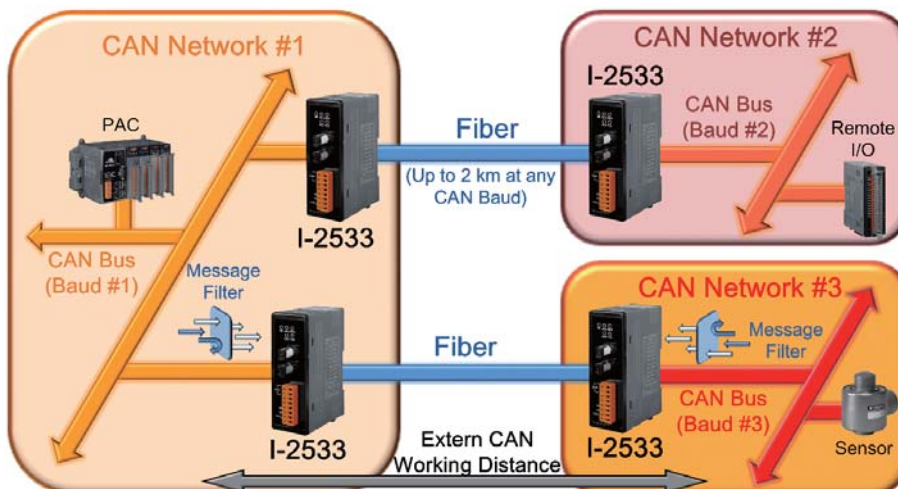

▶▶▶▶ Isolated 4-port CAN Bus Switch

I-2534 CR **NEW**

The I-2534 is a local CAN switch used to establish a connection between for CAN bus branches in a CAN network. It solves the problems of the daisy chain topology of the CAN bus. The transmission distance limitation of each CAN port of the I-2534 is independent, which means the total network distance can be extended.

- 4 CAN communication ports
- Compatible with CAN specification 2.0 parts A and B
- Support baud rate: 10 k, 20 k, 50 k, 125 k, 250 k, 500 k, 800 k, 1 M bps
- Message filter of each CAN port is configurable
- 3 kV DC-DC isolation
- Power requirement Unregulated +10 Vdc ~ +30 Vdc
- Humidity range 10 ~ 95% RH, non-condensing
- Fully compatible with the ISO 11898-2 standard
- Rotary switch for the baud rate of each CAN port
- Supports all CAN application layer protocols based on ISO 11898-2 standard
- Jumper for 120 Ω terminator resistor of CAN bus
- 2500 Vrms isolation
- Operation temperature: -25 °C ~ +75 °C

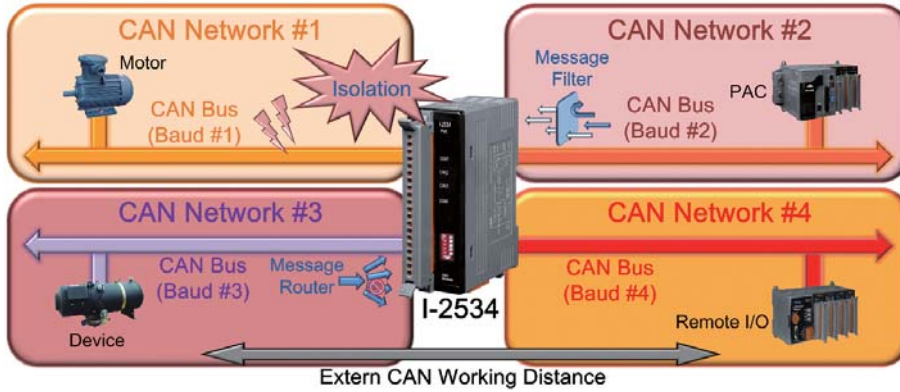

▶▶▶▶ Isolated CAN Bus Repeater

I-7531 CR

I-7531 is a CAN repeater used to establish a physical coupling of two or more segments of a CAN bus system. Users can implement tree or star topologies as well as for long drop lines with I-7531.

- Compatible with CAN specification 2.0 parts A and B
- Support several kinds of baud rate from 10 kbps to 800 kbps
- Jumper for 120 Ω terminator resistor of CAN bus
- 3 kV galvanic isolation among the power supply and two CAN channels
- Up to 100 nodes on each CAN port
- DIN-Rail Mounting
- Fully compatible with the ISO 11898-2 standard
- Watchdog inside
- 2500 Vrms photocoupler isolation on the CAN side
- Watchdog inside
- Two CAN channels
- Auto-baud detection
- Removable terminal block

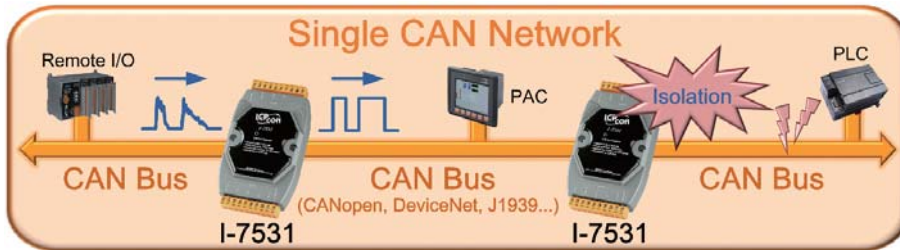

▶▶▶▶ Isolated CAN Bus Bridge

I-7532 CR

I-7532 is a CAN bridge to coupling different segments which can be different baud rates. It also can isolate the electronic disturbances between both sides. That can protect the nodes of one side from another.

- Compatible with CAN specification 2.0 parts A and B
- Support several kinds of baud rate from 10 kbps to 1 Mbps
- Jumper for 120 Ω terminator resistor of CAN bus
- 3 kV galvanic isolation between two CAN channels
- Configure CAN Baud of each channel by rotary switch
- Removable terminal block
- DIN-Rail Mounting
- Fully compatible with the ISO 11898-2 standard
- Watchdog inside
- 2500 Vrms photocoupler isolation on the CAN side
- Extend the CAN working distance
- Two CAN channels
- Up to 100 nodes on each CAN port



7-ch Surge Protector

SG-770 CR **NEW**

SG-770 offers 7 channels for surge protection. SG-770 is approved with IEC 61000-4-5 and IEC 61000-4-12 standards. Each of channels supports 0 V ~ 30 V signal and each of channels is protected for surge achieves 6 kV.

- Provide 7 differential or 14 single-ended channels
- 6 kV Surge Protection
- Max. Line Voltage: 30 Vdc
- Operating temperature: -25 °C ~ +75 °C
- Storage temperature: -30 °C ~ +80 °C
- Humidity: 10 ~ 90% RH, non-condensing
- Surge Waveform follows the standard IEC 61000-4-5 and IEC 61000-4-12
- Input signal type: voltage, current, thermocouple, RTD, RS-485/422, RS-232, CAN bus, and FRnet
- Propagation delay: 1 ns



CAN to RS-232 Converter

I-7530 CR

I-7530 is designed to unleash the power of CAN bus via RS-232 communication method. It converts messages between CAN networks and RS-232 networks.

- Compatible with CAN specification 2.0 parts A and B
- Support several kinds of baud rate from 10 kbps to 1 Mbps
- Watchdog inside
- One CAN port and one RS-232 port
- Support transparent communication mode
- DIN-Rail Mounting
- Fully compatible with the ISO 11898-2 standard
- 2500 V_{rms} photocoupler isolation on the CAN side
- Jumper for 120 Ω terminator resistor of CAN bus
- 3 kV galvanic isolation
- Configure CAN and RS-232 parameters by utility



Low-Speed/Fault-Tolerance CAN to RS-232 Converter

I-7530-FT CR

I-7530-FT is a CAN/RS-232 low speed fault tolerant converter. It can resist more noise in harsh environment, and even access CAN messages with single line of CAN bus. It can be used in the application of CAN bus monitoring, building automation, remote data acquisition, laboratory equipment & research, factory automation, etc.

- Microprocessor inside with 20 MHz
- Fully compatible with ISO 11898-3 standard
- Support both CAN 2.0A and CAN 2.0B
- Built-in RS-232/CAN FIFO buffers
- Hardware watchdog design
- Built-in CAN/RS-232 converter firmware
- Max transmission speed up to 125 kbps for CAN and 115.2 kbps for RS-232
- Power, data flow and error indicator for CAN and RS-232



CAN to RS-232/RS-422/RS-485 Converter

I-7530A CR

I-7530A is designed to unleash the power of CAN bus via RS-232/RS-422/RS-485 communication method. It correctly converts messages between CAN and RS-232/RS-422/RS-485 networks.

- Compatible with CAN specification 2.0 parts A and B
- Support several kinds of baud rate from 10 kbps to 1 Mbps
- Watchdog inside
- One CAN, RS-232, RS-422, and RS-485 channels
- Support transparent communication mode
- DIN-Rail Mounting
- Fully compatible with the ISO 11898-2 standard
- 2500 V_{rms} photocoupler isolation on the CAN side
- Jumper for 120 Ω terminator resistor of CAN bus
- 3 kV galvanic isolation
- Configure CAN and serial COM parameters by utility



CAN to Modbus RTU Slave Converter

I-7530A-MR CR **NEW**

The I-7530A-MR is a kind of CAN bus to RS-232/RS-422/RS-485 converter. Similar with I-7530A, it provides a way to connect CAN networks with programmable RS-232/RS-422/RS-485 devices. Specially, the I-7530A-MR provides Modbus protocol. This helps PLCs, HMIs, and SCADAs accessing CAN networks more easily and conveniently.

- Fully compatible with the ISO 11898-2 standard
- Support CAN bus acceptance filter configuration
- Support firmware update via UART
- Built-in jumper to select 120 Ω terminal resistor
- Power, data flow and error indicator for CAN and UART
- Convert CAN message to specific ASCII command string
- Provide pair-connection communication between the RS-232/485/422 devices via CAN bus
- Programmable CAN bus baud rate from 5 kbps to 1 Mbps or user-defined baud rate
- Provide utility tool for users module setting and CAN bus communication testing conveniently
- Hardware Watchdog design
- Convert specific ASCII command string to CAN messages
- Provide Modbus RTU command for Modbus master device to access CAN messages



CAN to Ethernet Converter

I-7540D CR

I-7540D is a solution that enables CAN networks to be coupled together over the Internet/Ethernet, whereby remote monitoring and control is possible. The I-7540D controls networked communication and makes a transparent CAN-based application interface available to the user.

- Compatible with CAN specification 2.0 parts A and B
- Support several kinds of baud rate from 10 kbps to 1 Mbps
- Watchdog inside
- 1 kV galvanic isolation
- Configure CAN, RS-232 and RS-485 parameters by web page
- Support for Virtual COM technology
- Fully compatible with the ISO 11898-2 standard
- 2500 V_{rms} photocoupler isolation on the CAN side
- Jumper for 120 Ω terminator resistor of CAN bus
- 10/100 Base-T Ethernet port
- One CAN, RS-232, RS-485 and Ethernet channels
- Provide max. 25 Ethernet clients connection



▶▶▶▶ CAN to Modbus TCP Server Converter

I-7540D-MTCP **NEW**

The I-7540D-MTCP can combine the CAN networks with the Internet/Ethernet. It can not only access the CAN network via Ethernet, but realize the CAN transparent transmission. I-7540D-MTCP also supports Modbus TCP/Modbus RTU protocol. This helps PLCs, HMIs, and SCADAs accessing CAN networks more easily and conveniently.

- Compatible with CAN specification 2.0 part A and B
- Provide one CAN, RS-232, RS-485 and 10/100 Base-T Ethernet channels
- Provide utility tool for monitor and configuraion
- Watchdog inside
- 1 kV galvanic isolation
- Fully compatible with the ISO 11898-2 standard
- Support several kinds of baud rate from 10 kbps ~ 1 Mbps
- Jumper for 120 Ω terminator resistor of CAN bus
- Support Modbus function code: 0x03/0x04/0x10
- 2500 Vrms photocoupler isolation on the CAN side



▶▶▶▶ CAN to Wi-Fi Converter

I-7540D-WF **NEW**

The I-7540D-WF supports the wireless transmission of CAN data between two CAN networks or between a CAN network and an 802.11 b/g WLAN network. It provides the function of CAN to WLAN converter and the wireless transparent transmission method on the CAN bus network.

- IEEE 802.11 b/g compliant
- Two different operation modes: infrastructure and ad-hoc
- Supports WEP, WPA and WPA2 encryption for wireless LAN
- Communication efficiency: one-way is up to 700 fps (client->server, server->client), two-way 350 fps (client<=>server)
- Wireless data transmission via WLAN
- Point to point or point to multi-points connection via wireless LAN
- Compatible with CAN specification 2.0 parts A and B
- Connect CAN networks via a WLAN bridge
- Wireless transmission distance: up to 100 meters



▶▶▶▶ USB to CAN Converter

I-7565 CR

I-7565 is a cost-effective device for connecting the CAN bus to PC via the standard USB interface.

- Compatible with CAN specification 2.0 parts A and B
- Support several kinds of baud rate from 10 kbps to 1 Mbps
- Watchdog inside
- 3 kV galvanic isolation
- One CAN port and one USB channel
- DIN-Rail Mounting
- Fully compatible with the ISO 11898-2 standard
- 2500 Vrms photocoupler isolation on the CAN side
- Jumper for 120 Ω terminator resistor of CAN bus
- Fully compliant with USB 1.1/2.0 (Full Speed)
- Powered by USB port
- Support Windows 98/ME/2000/XP and Linux drivers



▶▶▶▶ High Performance 1-port USB to CAN Converter

I-7565-H1 CR **NEW**

I-7565-H1 is a cost-efficient device for coupling one CAN channel to USB interface. With its powerful 32-bit microcontroller, transmission and reception processes can be controlled loss-free.

OS Support: Window 98/2K/XP/Vista, Linux

- Fully compatible with the ISO 11898-2 standard
- No external power supply (powered by USB)
- Programmable CAN bus baud rate from 5 kbps to 1 Mbps
- 3 kV galvanic isolation among the power supply
- Provide configuration utility to transmit/receive CAN messages
- Removable terminal block, DIN-Rail Mounting
- Compatible with CAN specification 2.0 parts A and B
- Integrated with one CAN bus interface
- Built-in jumper for 120 Ω terminal resistor of CAN bus
- 2500 Vrms photocoupler isolation on the CAN side
- Support CAN bus acceptance filter configuration
- Max. data flow for a single channel: 3000 fps (standard frame)



▶▶▶▶ High Performance 2-port USB to CAN Converter

I-7565-H2 CR **NEW**

I-7565-H2 is a cost-efficient device for coupling two CAN channels to USB interface. With its powerful 32-bit microcontroller, transmission and reception processes can be controlled loss-free.

OS Support: Window 98/2K/XP/Vista, Linux

- Fully compatible with the ISO 11898-2 standard
- No external power supply (powered by USB)
- Programmable CAN bus baud rate from 5 kbps to 1 Mbps
- 3 kV galvanic isolation among the power supply
- Provide configuration utility to transmit/receive CAN messages
- Removable terminal block, DIN-Rail Mounting
- Compatible with CAN specification 2.0 parts A and B
- Integrated with one CAN bus interface
- Built-in jumper for 120 Ω terminal resistor of CAN bus
- 2500 Vrms photocoupler isolation on the CAN side
- Support CAN bus acceptance filter configuration
- Max. data flow for a single channel: 3000 fps (standard frame)



CAN Bus μ PACs

▶▶▶▶ Standalone CAN/RS-232/RS-485 PAC

I-7188XBD-CAN CR

I-7188XBD-CAN PACs (Programmable Automation Controller) are powered by 80186, 40 MHz CPU with 512 KB SRAM and Flash. It can be applied to various applications because of its CAN port, RS-232 port and RS-485 port. Uses can program their application program flexibly with C/C++ language based on the built-in MiniOS7 operation system.

- 2500 V_{rms} photocoupler isolation on CAN bus
- Programmable transfer rate up to 1 Mbps
- 64-bit hardware unique serial number inside
- COM port: COM1, COM2
- One digital Input channel and one open collector output channel
- Built-in ICP DAS's MiniOS7
- Compatible with CAN specification 2.0 parts A and B
- Jumper for 120 Ω terminator resistor for CAN channel
- COM driver support interrupt & 1 k QUEUE input buffer
- Built-in RTC, NVRAM, EEPROM
- Built-in self-tuner ASIC controller on RS-485 port
- 7-segment LED display
- Support the CAN bus instead of the X-bus, so it can not be add-on any X-board



▶▶▶▶ Standalone Ethernet/CAN/RS-232/RS-485 PAC

μ PAC-7186EXD-CAN CR

μ PAC-7186EXD-CAN PACs (programmable Automation controller) are powered by 80186, 80 MHz CPU with 512 KB SRAM and Flash. It can adapt to the many applications because of its CAN, RS-232, RS-485 and Ethernet interfaces. Uses can program their application program flexibly with C/C++ language based on the MiniOS7 operation system.

- Embedded MiniOS7, anti-virus
- 10/100 Base-T Ethernet
- Support for Virtual COM configuration
- Compatible with CAN specification 2.0 parts A and B
- Jumper for 120 Ω terminator resistor for CAN channel
- COM port: COM1, COM2
- Built-in self-tuner ASIC controller on RS-485 port
- Supports a variety of TCP/IP features, including TCP, UDP, IP, ICMP, ARP
- 1000 Vbc voltage protection on CAN side
- Programmable transfer rate up to 1 Mbps
- 64-bit hardware unique serial number inside
- Built-in RTC, NVRAM, EEPROM
- 7-segment LED display



CAN Bus Modules

▶▶▶▶ Intelligent 1-port CAN I-8K Module

I-8120W CR *NEW*

I-8120W has one CAN communication port with 5-Pin screw terminal connector, and is useful for a wide range of CAN applications. Users can design the various applications between different communication protocols. It supports WinPAC-8000, XPAC-8000 and ViewPAC series PACs.

- Compatible with CAN specification 2.0 parts A and B
- Support several kinds of baud rate from 10 kbps to 1 Mbps
- Watchdog inside
- 8 K DPRAM inside
- Parallel bus communication with main unit
- Fully compatible with the ISO 11898-2 standard
- 2500 V_{rms} photocoupler isolation on the CAN side
- DIP switch for 120 Ω terminator resistor of CAN bus
- 3 kV galvanic isolation
- 80 MHz 186 CPU inside



▶▶▶▶ Intelligent 1-port CAN I-87K Module

I-87120 CR

I-87120 is developed to expand the CAN functions of ICP DAS products. The user-defined firmware supported by I-87120 can help users to set up the specific application easily. It supports WinPAC-8000, LinPAC-8000, XPAC-8000 and ViewPAC series PACs.

- Compatible with CAN specification 2.0 parts A and B
- Support several kinds of baud rate from 10 kbps to 1 Mbps
- Watchdog inside
- Serial bus communication with the main control unit
- Allow user-designed firmware
- Fully compatible with the ISO 11898-2 standard
- 2500 V_{rms} photocoupler isolation on the CAN side
- DIP switch for 120 Ω terminator resistor of CAN bus
- 3 kV galvanic isolation
- 80 MHz 186 CPU inside





CAN Bus Boards

▶▶▶▶ Isolated 1-port PCI-104 CAN Board

PCM-CAN100 CR **NEW**

The PCM-CAN100 is a PCI-104 CAN board. It complies with CAN 2.0A and CAN 2.0B specification, and can cover a wide range of CAN applications. The PCM-CAN100 provides one CAN port and one bypass CAN port. Both of them use the 9-Pin D-Sub connectors.

OS Support: Win2K/XP/Vista/7/CE, Linux 2.6.31 ~ 2.6.34

- PCI-104 compliant
- Compatible with CAN specification 2.0 parts A and B
- Support CAN board from 10 kbps ~ 1 Mbps
- Built-in jumper to select 120 Ω terminal resistor
- 1 independent CAN channel and 1 bypass CAN channel
- Provide VB6.0, VC++6.0, Delphi, BCB6.0 demos
- 9-Pin male D-Sub connector
- Fully compatible with ISO 11898-2 standard
- 2500 V_{rms} photocoupler isolation on the CAN side
- 3 kV galvanic isolation
- Support LabVIEW and DASyLab drivers



▶▶▶▶ Isolated 2-port PCI-104 CAN Board

PCM-CAN200 CR **NEW**

The PCM-CAN200 is a CAN solution with the PCI-104 interface. It complies with CAN 2.0A and CAN 2.0B specification, and can cover a wide range of CAN applications. The PCM-CAN200 provides two CAN ports. Both of them use the 9-Pin D-Sub connectors.

OS Support: Win2K/XP/Vista/7/CE, Linux 2.6.31 ~ 2.6.34

- PCI-104 compliant
- Compatible with CAN specification 2.0 parts A and B
- Support CAN board from 10 kbps ~ 1 Mbps
- Built-in jumper to select 120 Ω terminal resistor
- 2 independent CAN channels
- Provide VB6.0, VC++6.0, Delphi, BCB6.0 demos
- 9-Pin male D-Sub connector
- Fully compatible with ISO 11898-2 standard
- 2500 V_{rms} photocoupler isolation on the CAN side
- 3 kV galvanic isolation
- Support LabVIEW and DASyLab drivers



▶▶▶▶ Isolated 2-port PC/104-Plus CAN Board

PCM-CAN200P CR **NEW**

The PCM-CAN200P has 2 independent CAN ports with 9-Pin D-Sub connector, and is compatible with the PC/104-Plus specification. It is a economic CAN solution for the embedded system.

OS Support: Win2K/XP/Vista/7/CE, Linux 2.6.31 ~ 2.6.34

- PC/104-Plus compliant
- Compatible with CAN specification 2.0 parts A and B
- Support CAN board rate from 10 kbps ~ 1 Mbps
- Built-in jumper to select 120 Ω terminal resistor of CAN bus
- 2 independent CAN ports
- Provide VB6.0, VC++6.0, Delphi, BCB6.0 demos
- 9-Pin D-Sub connector
- Fully compatible with ISO 11898-2 standard
- 2500 V_{rms} photocoupler isolation on the CAN side
- 3 kV galvanic isolation
- Support LabVIEW and DASyLab drivers



▶▶▶▶ Intelligent 1-port PCI-104 CAN Board

PCM-CM100 CR **Available soon**

The PCM-CM100 is a PCI-104 CAN board with 80 MHz CPU and 8 kB DPRAM, and suits for high performance embedded systems. Besides, it is allowed to develop your own firmware into the board. Therefore, the complex CAN tasks can be done by the board, not PC.

OS Support: Windows 2K/XP/Vista

- PCI-104 compliant
- Compatible with CAN specification 2.0 parts A and B
- Support several kinds of baud rate from 10 kbps ~ 1 Mbps
- Built-in jumper to select 120 Ω terminal resistor
- 80186, 80 MHz CPU inside
- Provide VB, VC++, Delphi, Borland C++ builder demos
- 9-Pin male D-Sub connector
- Fully compatible with ISO 11898-2 standard
- 2500 V_{rms} photocoupler isolation on the CAN side
- 3 kV galvanic isolation
- Allow users to program their special firmware
- Support LabVIEW and DASyLab drivers



▶▶▶▶ Isolated 2-port PCI-Express CAN Board

PEX-CAN200i CR **NEW**

The PEX-CAN200i series has 2 independent CAN ports with 5-Pin screw terminal connector or 9-Pin D-Sub connector with the PCI Express x 1 bus. Every CAN channel has isolation protection circuit.

OS Support: Win2K/XP/Vista/7, Linux 2.6.31 ~ 2.6.34

- Compatible with CAN specification 2.0 parts A and B
- Support several kinds of baud rate from 10 kbps to 1 Mbps
- Built-in jumper for 120 Ω terminator resistor of CAN bus
- 3 kV galvanic isolation
- Direct memory mapping to the CAN controller
- Support LabVIEW and DASyLab drivers
- Fully compatible with the ISO 11898-2 standard
- 2500 V_{rms} photocoupler isolation on the CAN side
- X1 link PCI Express
- 2 independent CAN channels
- Provide VB, VC++, Delphi, Borland C++ builder demos

PEX-CAN200i-D



PEX-CAN200i-T

▶▶▶▶ Isolated 1/2/4/8-port Universal PCI CAN Board

- PISO-CAN100U CR *Available soon*
- PISO-CAN200U CR
- PISO-CAN400U CR
- PISO-CAN800U CR *Available soon*

The PISO-CANx00U is a economic CAN interface solution. The character x indicates the port numbers of one CAN board, and would be 1, 2, 4, or 8. The PISO-CANx00U provides 5-Pin screw terminal connector or 9-Pin D-Sub connector for different applications.

OS Support: Win2K/XP/Vista/7, Linux 2.6.31 ~ 2.6.34

- Universal PCI board, supports both 5 V and 3.3 V PCI bus
- Fully compatible with the ISO 11898-2 standard
- 2500 V_{rms} photocoupler isolation on the CAN side
- Comply with 33 MHz 32-bit 5 V universal PCI bus
- Provide 1/2/4/8 independent CAN channels
- Provide VB, VC++, Delphi, Borland C++ builder demos
- Compatible with CAN specification 2.0 parts A and B
- Support several kinds of baud rate from 10 kbps to 1 Mbps
- Built-in jumper for 120 Ω terminator resistor of CAN bus
- 3 kV galvanic isolation
- Direct memory mapping to the CAN controller
- Support LabVIEW and DASyLab drivers

PISO-CAN400U-D



PISO-CAN400U-T

▶▶▶▶ Intelligent 1-port Universal PCI CAN Board

PISO-CM100U CR

The PISO-CM100U is a Universal PCI CAN board with 80 MHz CPU and 8 kB DPRAM, and suits for time-critical applications. Besides, it is allowed to develop your own firmware into the board. Therefore, the PISO-CM100U can efficiently share the CPU loading of your PC.

OS Support: Windows 2K/XP/Vista

- Universal PCI board, supports both 5 V and 3.3 V PCI bus
- Support several kinds of baud rate from 10 kbps to 1 Mbps
- 3 kV galvanic isolation
- 80186, 80 MHz CPU inside
- Allow users to program their special firmware
- Support LabVIEW and DASyLab drivers
- Compatible with CAN specification 2.0 parts A and B
- Fully compatible with the ISO 11898-2 standard
- 2500 V_{rms} photocoupler isolation on the CAN side
- Built-in jumper for 120 Ω terminator resistor of CAN bus
- Provide VB, VC++, Delphi, Borland C++ builder demos

PISO-CM100U-D



PISO-CM100U-T

CAN Bus Power Meters

▶▶▶▶ 3-phase/4-loop 1-phase Compact Power Meter

- PM-2133-CAN series CR *NEW*
- PM-2134-CAN series CR *NEW*

PM-213X-CAN series power meter is used for gathering the real-time power consumption information by the CAN interface. It supports not only polling mode, but Auto-response mode which let the power meter automatically reply the CAN messages in the predefine time period. This makes the communication more efficient while building a large power monitor system.

- True RMS energy and power parameters measurement in compact size
- RS-485 communication supported Modbus RTU protocol
- Wh accuracy better than 1% (PF=1)
- PM-2133-CAN is 3-phase power meter
- Easy wiring for on-line installation
- CAN bus communication compatible with CAN specification 2.0B
- With wired clip-on CT (support input current up to 200A)
- PM-2134-CAN is 4-Loops 1-phase Compact power meter

PM-2133-CAN series



PM-2134-CAN series

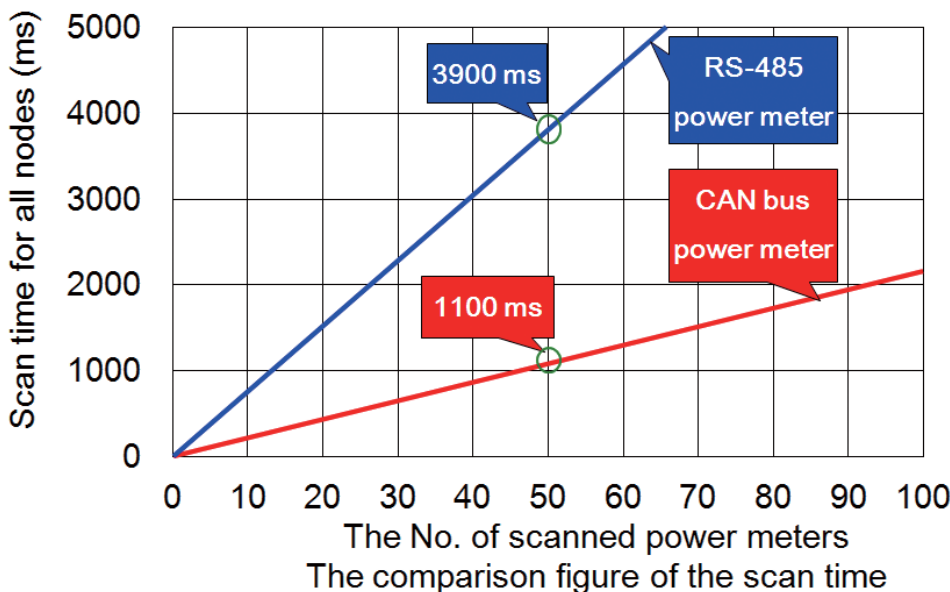

• CAN bus Software

Model Name	Description	Page
RTX CAN Driver	CAN bus RTX driver for PISO-CAN/PEX-CAN/PCM-CAN series boards	5-2-11
LabVIEW CAN Driver	CAN bus LabVIEW driver for PISO-CAN/PEX-CAN/PCM-CAN series boards	5-2-11
DASYLab CAN Driver	CAN bus DASYLab driver for PISO-CAN/PEX-CAN/PCM-CAN series boards	5-2-12
SocketCAN Device Driver	CAN bus Linux driver for PISO-CAN/PEX-CAN/PCM-CAN series boards	5-2-12
PISOCANX ActiveX Object	CAN bus ActiveX object for PISO-CAN/PEX-CAN/PCM-CAN series boards	5-2-12
NAPOPC.CAN DA Server	CAN bus OPC Server for converters & CAN boards	5-2-12

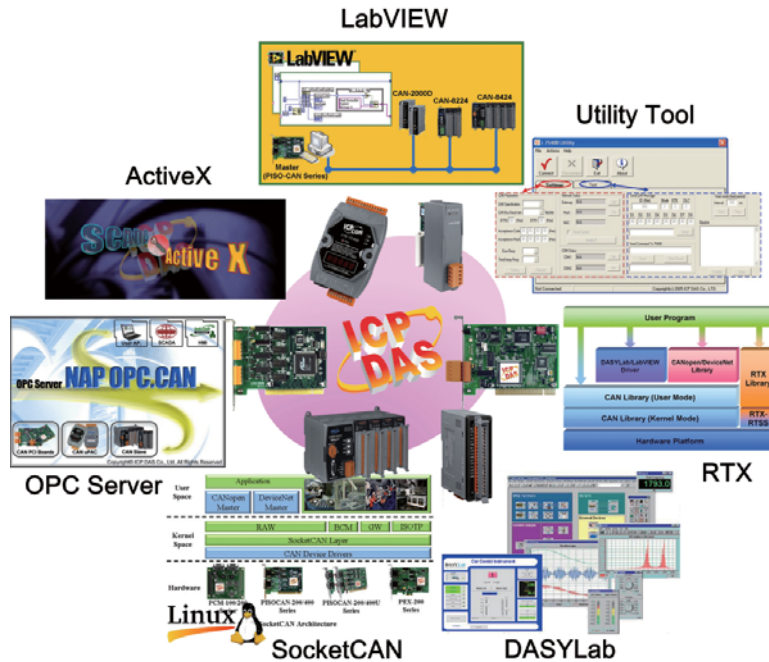

▶▶▶▶ CAN Bus RTX Driver for PISO-CAN/PEX-CAN/PCM-CAN Series Boards

RTX CAN Driver

The RTX CAN Driver helps users to develop the highly real-time CAN bus applications on Windows OS by PISO-CAN series in ICP DAS. The name and parameters of the APIs in the RTX driver are the same as in the Windows driver. Users don't need to pay more efforts to study how to use the APIs of the RTX driver.

- Support interrupt function if the PISO-CAN series CAN board can get the independent IRQ
- Direct I/O control and highly real-time feature
- Support Windows2000 SP4, and Windows XP SP2 OS
- Support RTX version 8.0 or later
- Provide VC 6.0 demos
- Real-time Test:
 - Platform: Windows XP SP2 + PEX-CAN200i
 - Device: I-7186EXD-CAN with MiniOS7 (single tasking OS)
 - Method: Send and receive 10000 CAN 2.0B 8-byte messages
 - Repeat this procedure for 10 times

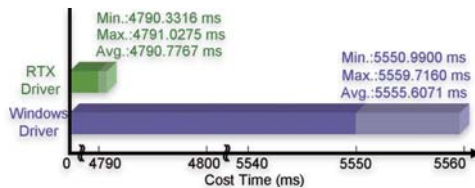

▶▶▶▶ CAN Bus LabVIEW Driver for PISO-CAN/PEX-CAN/PCM-CAN Series Boards

LabVIEW CAN Driver

In order to apply CAN bus technology under the LabVIEW development environment, ICP DAS develops the CAN LabVIEW driver and corresponding VI elements for all PISO-CAN series CAN boards. Using LabVIEW development environment with the CAN LabVIEW driver helps users finishing their job quickly and easily, and also simply the users' CAN applications.

- NI LabVIEW Software version 8.0 or later
- OS environment: Windows 2000/XP
- Support CAN specification 2.0A and 2.0B
- Predefine 8 kinds of CAN baud rate: 10 k, 20 k, 50 k, 125 k, 250 k, 500 k, 800 k and 1M bps
- Allow user-defined CAN baud rate
- Provide 3000-record Rx buffer for each CAN port
- Support functions for directly accessing SJA1000 register
- Allow users to read the board No. and relative information
- Support timestamp information for each received CAN messages

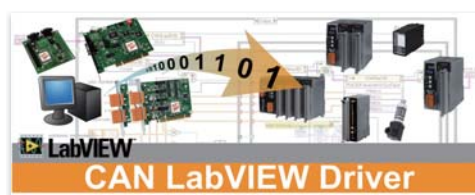

▶▶▶▶ CAN Bus DASyLab Driver for PISO-CAN/PEX-CAN/PCM-CAN Series Boards

DASyLab CAN Driver

DASyLab is a kind of data acquisition software. It lets you interactively develop PC-based applications by simply attaching functional icons. DASyLab offers real-time analysis, control, and the ability to create custom graphical user interfaces. In order to use DASyLab software with the PISO-CAN series boards, we provide the DASyLab CAN driver for the purpose.

- Support DASyLab software version 8.0
- OS environment: Windows 2000/XP
- Support CAN specification 2.0A and 2.0B
- Allow user-defined CAN baud rate
- Support maximum 64 CAN ports
- Sample rate from 50 ~ 5000 Hz
- Block size range is 1 ~ 4096
- Provide Intel mode and Motorola mode for remote CAN device
- Support two kinds of languages, German and English
- Selectable data rates (baud): 10K, 20K, 50K, 125K, 250K, 500K, 800K, 1M, and user defined



▶▶▶▶ CAN Bus Linux Driver for PISO-CAN/PEX-CAN/PCM-CAN Series Boards

SocketCAN Device Driver

SocketCAN driver is a kind of device driver based on the Linux operating system, and it contains the implementation interface of the network stack and the hardware driver. The hardware manufacturers develop the hardware driver of SocketCAN driver for their hardware interface, and the network stack provides the standard BSD Socket APIs for users.

- Support Linux kernel version 2.6.31~2.6.34 (x86 hardware platform only)
- Provide CANopen/DeviceNet master static library
- Standard interface for SocketCAN package. Users can use extended BSD socket APIs, you can program the CAN application as building a socket program
- Support Virtual CAN interface. Users can map several virtual CAN port into one physical CAN port. Each virtual CAN port has its own socket. Through these sockets, users can build the multi-thread application more easily
- Provide the RAW socket, CANopen master and DeviceNet master demos
- Good price-performance for economical applications

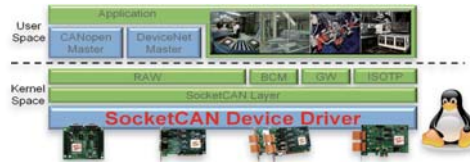

▶▶▶▶ CAN Bus ActiveX Object for PISO-CAN/PEX-CAN/PCM-CAN Series Boards

PISOCANX ActiveX Object

PISOCANX uses ActiveX technology to simplify the procedure while developing the application by using PISO-CAN series CAN board. The ActiveX object (OCX) can be not only used in general program development environment, but used in the SCADA software which supports the ActiveX technology.

- OS environment: Windows 2000/XP
- Allow polling mode and interrupt mode
- Provide 3000-record Rx buffer for each CAN port
- Support functions for directly accessing SJA1000 register
- Allow users to read the board No. and relative information
- Support timestamp information for each received CAN messages
- VC6, VB demos are given



▶▶▶▶ CAN Bus OPC Server for Converters & CAN Boards

NAPOPC.CAN DA Server

NAPOPC.CAN DA Server is a CAN OPC server to be as an expert bridge between ICP DAS CAN products and the OPC client of the third party software. Besides, it also provides the easy-to-use integral APIs to access the different CAN ports without through the OPC server.

- OS environment: Windows 2000/XP
- Follow OPC 1.0, OPC 2.0 Data Access Standards
- Configure CAN baud rate with OPC utility
- Configure CAN hardware filter by the APIs of the Virtual CAN Driver
- Provide CAN Engine Utility to monitor the CAN messages
- Collect the data from the different CAN devices in one OPC server
- Provide the CAN devices and the virtual CAN port No. mapping table
- Load previous configuration or scan all CAN devices manually while the Virtual CAN Driver boots up
- Provide the APIs of the Virtual CAN Driver



● Accessories

Model Name	Description	Page
CNT-CAN	CAN bus connector	5-2-13
CA-0910-C	9-Pin D-Sub female connector to 3-wire CAN bus cable	5-2-13

 CAN Bus Connector

▶▶▶▶ CAN Bus Connector

CNT-CAN CR **NEW**

CNT-CAN connector is used for connecting a CAN bus node to the CAN bus line featuring quick-connect technology, making the stripping of bus conductors superfluous. The connector is quick to install, and has a plastic housing and integrated terminating resistors. Anyway the CNT-CAN could link a CAN device to a CAN bus line easily and fast.

- Built-in switch to select 120 Ω terminal resistor
- 2 cable entries
- Cable outlet: 90° cable outlet
- Connector: 9-Pin, D-Sub male & female connector
- Programming connection : 9-Pin, D-Sub male connector
- Baud rate: 10 kbps ~ 1 Mbps
- Operation temperature: -25 °C ~ +75 °C
- Storage temperature: -30 °C ~ +80 °C
- Humidity: 10 ~ 90% RH, non-condensing



Installation



 CAN Bus Cable

▶▶▶▶ 9-Pin D-Sub Female Connector to 3-wire CAN Bus Cable

CA-0910-C **NEW**

The CA-0910-C, a 9-Pin D-Sub female to 3-wire CAN bus cable, is used for building build the connections between the two CAN devices which have different wiring methods. By applying this cable, the user doesn't need to make a transformation connector by himself any more.

- Length: 1 meter
- Wire terminal: 3-wire for CAN_H, CAN_L, and CAN_GND
- Connector terminal : 9-pin, D-Sub female connector
- Baud rate: 10 kbps ~ 1 Mbps
- Operating temperature: -25 °C ~ +75 °C
- Storage temperature: -30 °C ~ +80 °C
- Humidity: 10 ~ 90% RH, non-condensing

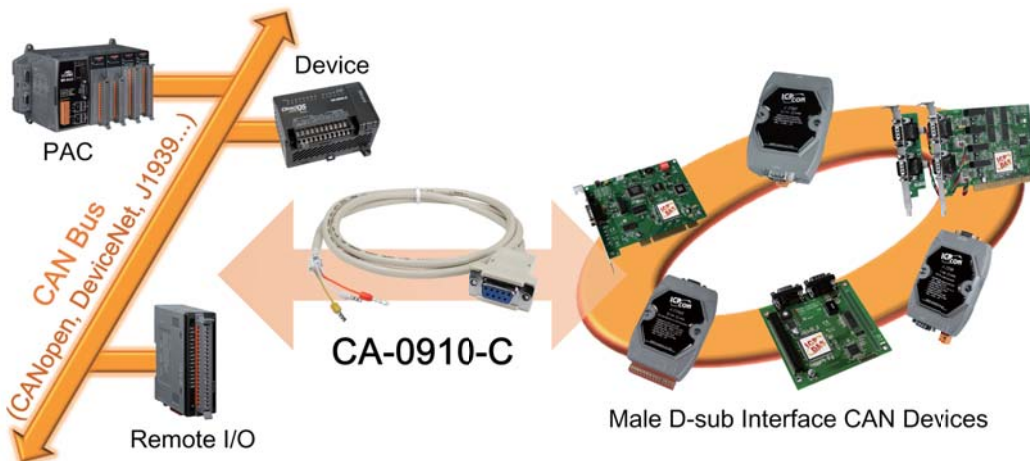

5-3 CANopen Introduction & Products

• Introduction

CANopen is a kind of network protocol based on CAN bus and has been used in various applications, such as vehicles, industrial machines, building automation, medical devices, maritime applications, restaurant appliances, laboratory equipment & research.

ICP DAS has been developing CAN-based CANopen protocol products for several years. Our products include PCI interface, gateway, CANopen IO and CANopen module for ICP DAS's ViewPAC/WinPAC/LinPAC/XPAC.

We also help customers solving various CANopen network technology problems. In addition, we can provide comprehensive CANopen solutions for users.

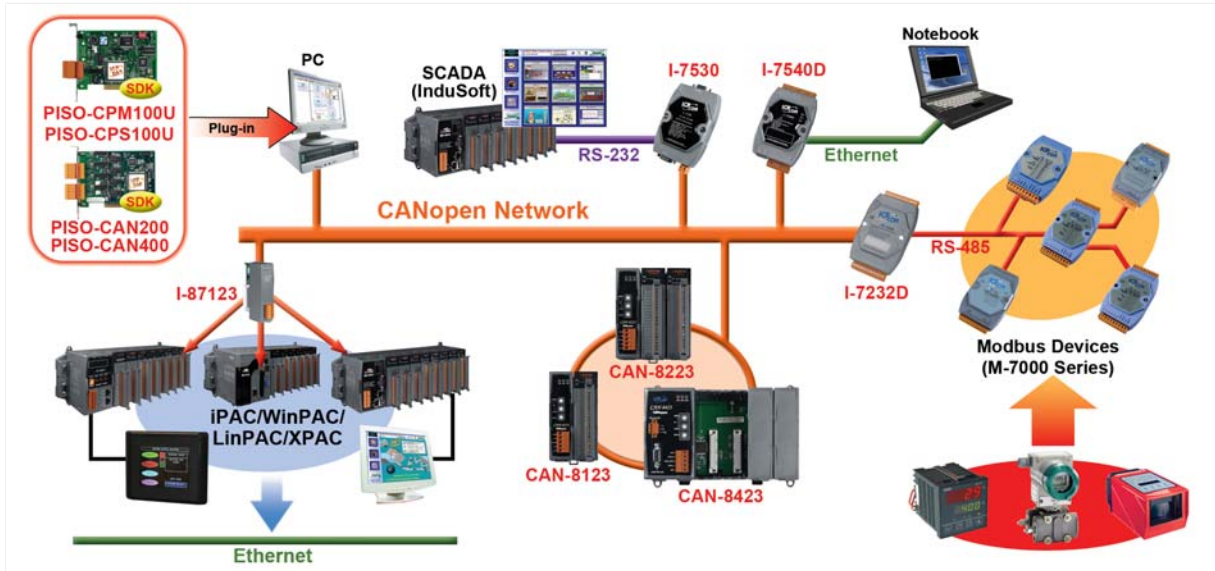

CANopen Features

- Comply with CANopen DS-301 v4.02
- Slave series comply with CANopen DSP-401 v2.1
- NMT Error Control support Node Guarding and Heartbeat protocol
- Provide Event-triggered, remote-requested, cyclic and acyclic SYNC of PDO mode
- Master series support listen mode
- Master series support Scan-node function
- Support EDS file
- Selectable Node-id (1 ~ 127) and baud rate (10, 20, 50, 125, 250, 500, 800, 1000 kbps)
- Built-in jumper or DIP switch for 120 Ω terminator resistor of CAN bus
- Built-in watchdog
- 3000 V_{dc} isolation for DC-to-DC
- 500 V_{rms} isolation on CAN bus

Multi-Master Feature

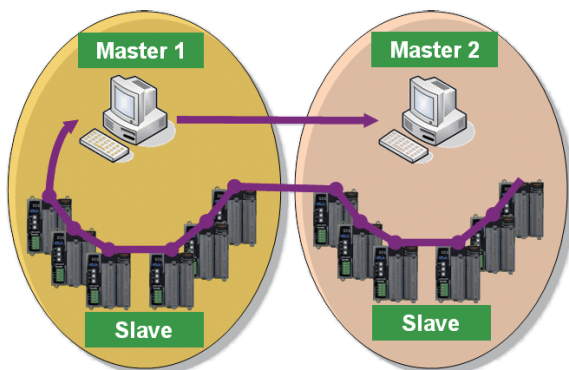

CANopen Master Utility

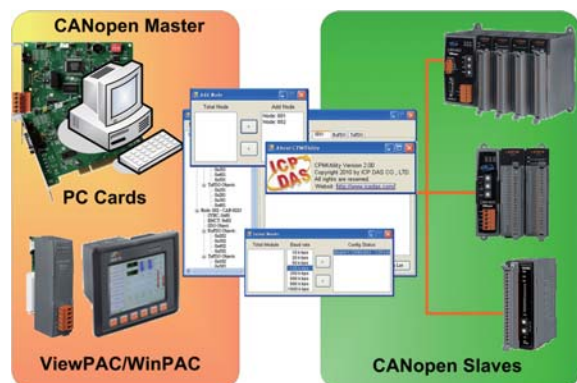

● Application Stories

▶▶▶▶ Winding Machine

Product: I-8123W, CAN-2017C, CAN-2053C, CAN-5057C, WP-8441, I-8094A

When the quality of motors is required to upgrade gradually, the precise and the fast motor equipment is more and more important. The high speed motor winding machine uses I-8123W to monitor and control the distributed I/O data through CANopen network. When the I-8123W gets these input data such as tension sensor, pressure sensor, and so on, the WinPAC will output the CANopen DO and the motion signal to control relay, switch, pneumatic valve, and robot to do the winding. As the CANopen features, fast and safe, it can really improve the speed and quality.



▶▶▶▶ Oil-Water Separator System

Product: PISO-CPM100U, I-7532, CAN-2017C, CAN-2054C

This is an oil-water separator system. The crude oil has several impurities and the majority is water. So we need to design a system to dehydrate crude oil. There are several oil-water separators spread around the control center and hundreds meters distance between each equipment. In the control center, PC receives the data that is sent by every oil-water interface detector through PISO-CPM100U and controls the water outlet valve. If the PISO-CPM100U checking the water, the PC will open the water outlet valve until checks the oil. Now this system has worked in some factories.

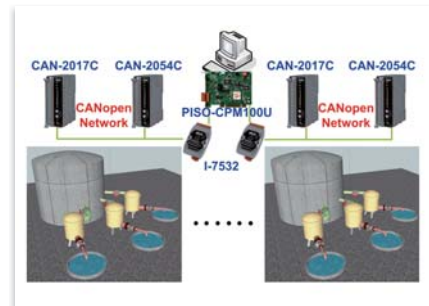

▶▶▶▶ Corrugated Carton Cutting Machine

Location: Taichung, Taiwan
Product: WP-8441, I-87123

In this case, the orientation and cutting speeds seriously affect the quantity of output. Because all of the cutting knives and rollers must be controlled by 31 motors, the customer selects the CANopen motors to do that. The WP-8441 and I-87123 play the role of a CANopen master to control all of the motors simultaneously by the CANopen features of the synchronization and high speed. By using this architecture, all of the motors can quickly move to the target position at the same time by just sending one command.

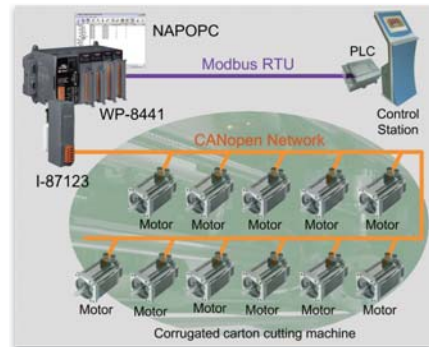

▶▶▶▶ MRI Cooling System

Location: Guangdong, China
Product: I-7232D

In order to reduce the cost, a MRI manufacturer uses the chiller made in China instead of German product. However, the customer gets into trouble with the different communication interface. By using the I-7232D, this problem is solved. I-7232D can be the Modbus RTU master while talking with the chiller. In the CANopen network, I-7232D is a CANopen slave. Therefore, I-7232D can easy bypass the information of the chiller to the CANopen master, and transfer the CANopen commands to the chiller.

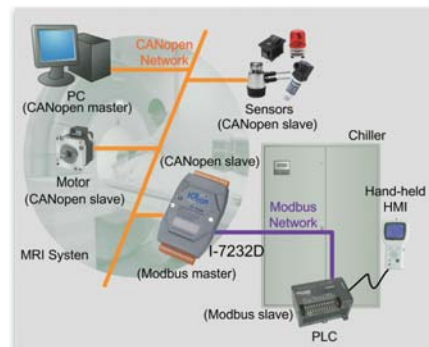

• Selection Guide

Model Name	CANopen Ports	Interface	Description	Page
CANopen Gateways				
GW-7433D	1	CANopen master ↔ Ethernet/RS-232/RS-485	CANopen master to Modbus TCP/RTU slave gateway	5-3-3
I-7231D	1	CANopen slave ↔ RS-485	CANopen slave to DCON master gateway	
I-7232D	1		CANopen slave to Modbus RTU master gateway	
CANopen Modules				
I-7565-CPM	1	USB ↔ CANopen master	Intelligent USB to CANopen master converter	5-3-4
I-8123W	1	CANopen master, Backplane parallel bus	Intelligent CANopen master I-8K module	
I-87123	1	CANopen master, Backplane serial bus	Intelligent CANopen master I-87K module	
CANopen Boards				
PISO-CPM100U	1	CANopen master, universal PCI bus	Intelligent CANopen master universal PCI board	5-3-4
PISO-CPS100U	1	CANopen slave, universal PCI bus	Intelligent CANopen slave universal PCI board	

• Product Showcase

CANopen Gateways

▶▶▶▶ CANopen Master to Modbus TCP/RTU Slave Gateway

GW-7433D CR *NEW*

The GW-7433D is a solution that provides a communication transformation between CANopen protocol and Modbus/TCP protocol. It solves a mission-critical problem, and connecting an existed CANopen network with Ethernet-base master device as long as this master device supports Modbus/TCP protocol. It enables CANopen networks to be coupled together with the Internet/Ethernet, whereby remote monitoring and controlling is achieved.

- CANopen Version: DS-301 v4.02
- Error Control: Node Guarding protocol
- 2500 V_{rms} photocoupler isolation on the CAN side
- Watchdog inside
- PDO: Event-triggered, RTR
- Allow 5 Modbus TCP masters to access GW-7433 simultaneously
- Emergency Message: Yes
- Jumper for 120 Ω terminator resistor of CAN bus
- NMT: Master
- Support max. 50 TxPDOs, 50 RxPDOs, 15 SDOs to SDO server
- Configuration by utility via Ethernet
- 1 kV galvanic isolation



▶▶▶▶ CANopen Slave to DCON Master Gateway

I-7231D CR

I-7231D is a CANopen slave and a DCON master device. It can produce or consume the PDO messages, receive the SDO message with proper responses, and deal with the NMT messages from NMT master. In the DCON network, it can scan all the DCON slave device, and do the data-exchange with CANopen master.

- CANopen Version: DS-301 v4.02, DSP-401 v2.01
- Error Control: Node Guarding protocol
- 2500 V_{rms} photocoupler isolation on the CAN side
- Watchdog inside
- PDO: Event-triggered, RTR, cyclic, acyclic SYNC and dynamic PDO mapping
- Support max. 15 I-7000/I-87K I/O series modules
- Jumper for 120 Ω terminator resistor of CAN bus
- NMT: Slave
- No of SDOs: 1 server, 0 client
- Product EDS file dynamically by utility



▶▶▶▶ CANopen Slave to Modbus RTU Master Gateway

I-7232D CR

The I-7232D follows the CANopen Spec DS-301 v4.02 and DSP-401 v2.1, and supplies many features for user, such as dynamic PDO, EMCY object, error output value, SYNC cyclic and acyclic. The I-7232D supports up to 10 Modbus/RTU modules for I/O expansion. User can choose DI/DO/AI/AO modules of Modbus/RTU series to fit the customized practice applications.

- CANopen Version: DS-301 v4.02, DSP-401 v2.01
- Error Control: Node Guarding protocol
- 2500 V_{rms} photocoupler isolation on the CAN side
- Watchdog inside
- PDO: Event-triggered, RTR, cyclic, acyclic SYNC and dynamic PDO mapping
- Support max. 10 Modbus RTU series modules
- Jumper for 120 Ω terminator resistor of CAN bus
- NMT: Slave
- No of SDOs: 1 server, 0 client
- Product EDS file dynamically by utility
- 1 kV galvanic isolation





CANopen Modules

Intelligent USB to CANopen Master Converter

I-7565-CPM CR **NEW**

The I-7565-CPM is an USB to CANopen master convertor. It can be applied with the USB port of the PC or notebook easily and does not need any extra power. I-7565-CPM can represent an economic solution of CANopen application and be a CANopen master device on the CANopen network.

- Fully compliant with USB 1.1/2.0 (Full Speed)
- CANopen Version: DS-301 v4.02
- Support Node Guarding and Heartbeat consumer protocol
- SYNC producer 1 ms ~ 65535 ms
- Slave Node: 127 nodes max.
- Windows 2000/XP drivers supported
- Power by the USB interface
- Baud Rate: 10 k, 20 k, 50 k, 125 k, 250 k, 500 k, 800 k, 1 Mbps
- Support dynamic PDO/SDO segment protocol
- Support auto-scan slave device function
- Free utility to configure I-7565-CPM and update firmware



Intelligent CANopen Master I-8K Module

I-8123W CR **NEW**

The I-8123W follows CiA CANopen specification DS-301 V4.02. It is a high price/performance CANopen master. With the ViewPAC, WinPAC, or XPAC series MCU (main control unit), it can be generally applied in the industrial automation, building automation, vehicle, and embedded control network. Besides, owing to the feature of building the CANopen protocol firmware inside, users can easily access the slave devices via I-8123W without studying or dealing the complex CANopen protocol. It is helpful to reduce the development cycle time and let users set up their CANopen application more quickly and easily.

- NMT Master
- Support Node Guarding and Heartbeat Consumer error control protocol
- Provide "Master Listen Mode for monitor"
- Support ViewPAC, WinPAC, and XPAC series PAC
- CANopen Version: DS-301 V4.02
- Provide EMCY and NMT Error Control interrupt service function
- Provide Dynamic PDO, acyclic and cyclic transmission



Intelligent CANopen Master I-87K Module

I-87123 CR

The I-87123 module is specially designed as the master device of CANopen protocol. It supplies the user with many features, such as dynamic PDO, EMCY object, error output value, SYNC object, and etc.. It can be applied in WinPAC-8000, LinPAC-8000, XPAC-8000 and ViewPAC series PACs.

- CANopen Version: DS-301 v4.02
- Emergency Message: Yes
- DIP switch for 120 Ω terminator resistor of CAN bus
- NMT: Master
- Provide C/C++ function libraries and demos
- 3 kV galvanic isolation
- Error Control: Node Guarding protocol
- 2500 V_{rms} photocoupler isolation on the CAN side
- PDO: Event-triggered, RTR, cyclic, acyclic SYNC and dynamic PDO mapping
- Serial bus communication



CANopen Boards

Intelligent CANopen Master Universal PCI Board

PISO-CPM100U CR

The PISO-CPM100U has followed the CiA CANopen specification DS-301 V4.02. With the built-in 80186, 80 MHz CPU, this card can be applied in high transmission applications. The 16-bit on-board microcontroller with real-time O.S., MiniOS7, provides many features such as real-time message transmission and reception, filtering, preprocessing, and storage of CAN messages. It supports the timestamp of PDO message with at least 1 ms precision. Assorted with the free tool (CPM_Utility), users can easily manage and integrate with CANopen industrial devices.

- Universal PCI card, supports both 5 V and 3.3 V PCI bus
- CANopen Version: DS-301 v4.02
- Built-in jumper for 120 Ω terminator resistor of CAN bus
- NMT: Master
- Support multi-master architecture
- 3 kV galvanic isolation
- Error Control: Node Guarding and Heartbeat consumer protocol
- 2500 V_{rms} photocoupler isolation on the CAN side
- PDO: Event-triggered, RTR, cyclic, acyclic SYNC and dynamic PDO mapping
- 80186, 80 MHz CPU inside

PISO-CPM100U-D



PISO-CPM100U-T

Intelligent CANopen Slave Universal PCI Board

PISO-CPS100U CR

PISO-CPS100U is an especially programmable CANopen Slave board. It provides a universal PCI interface and one CAN communication port. It follows the CANopen specification DS-301 and DSP-401. With the built-in 80186, 80 MHz CPU, this board can be applied in high transmission applications.

OS Support: Windows 2K/XP/Vista

- Universal PCI board, supports both 5 V and 3.3 V PCI bus
- Built-in Dual-watchdog protection
- CANopen profile: DSP401, version 2.01
- NMT Error Control: Node Guarding protocol & Heartbeat protocol
- Support dynamic PDO
- Programmable 512 bytes input data and 512 bytes output data
- Status LED: RUN, ERR
- Produce EDS file dynamically
- CPU: 80186, 80 MHz
- CANopen Version: DS301, version 4.02
- Baud Rate (bps): 10 k, 20 k, 50 k, 125 k, 250 k, 500 k, 800 k, 1 Mbps
- SYNC consumer
- Support SDO segment protocol
- Serial bus communication
- Support Save and Load command
- Free utility to configure PISO-CPS100U and update firmware
- Windows 2000/XP drivers supported

PISO-CPS100U-D



PISO-CPS100U-T

• CANopen Software

Model Name	Description	Page
Compact CANopen Library	CANopen master Library for PISO-CAN/PEX-CAN/PCM-CAN series CAN boards	5-3-5
CANopen Master Utility	CANopen master utility for ICP DAS CANopen master devices	5-3-5
CANopen Master InduSoft Driver	CANopen master InduSoft driver for I-8123W, PISO-CPM100U and I-7565-CPM devices	5-3-5
CANopen Master LabVIEW Driver	CANopen master LabVIEW driver for PISO-CPM100U and I-7565-CPM	5-3-5

▶▶▶▶ CANopen Master Library for PISO-CAN/PEX-CAN/PCM-CAN Series CAN Boards

Compact CANopen Library

We provide compact CANopen master library and CANopen diagnosis tool for PISO-CAN series CAN cards. The CANopen master library is helpful for developing an industrial application with CANopen protocol. If the monitor and diagnosis CAN network is considered, the CANopen diagnostic application tool can be used to achieve this purpose.

- NMT: Master
- CANopen Version: DS-301 v4.02
- Support up to 127 nodes
- Error Control: Support Guarding protocol
- Support EMCY receiving
- Provide dynamic PDO functions
- Support SYNC protocol
- Support SDO segment and block protocol
- Driver support Win 98/ME/NT/2K/XP and Linux



▶▶▶▶ CANopen Master Utility for ICP DAS CANopen Master Devices

CANopen Master Utility

In order to help users easily using the CANopen master communication boards, the PISO-CPM100(U), the CPMUtility tool is given. The utility includes several functions, such as NMT protocol, SYNC protocol, EMCY protocol, SDO protocol, PDO protocol, and so forth. These functions are useful for monitoring and controlling the CANopen devices.

- Auto-scan all the CANopen slave devices on the CANopen network
- Support EDS file
- Easy to set the dynamic PDO mapping objects
- Guarding Event and Heartbeat Event detection
- EMCY message reception
- Maximum 5 SYNC message producers per CANopen master
- Support PISO-CPM100(U), I-8123W, I-87123 with firmware version 2.00 or later
- Support OS: WinCE5.0 and Win2K/XP/Vista/7 with 32-bit system



▶▶▶▶ CANopen Master InduSoft Driver for I-8123W, PISO-CPM100U and I-7565-CPM Devices

CANopen Master InduSoft Driver

The CANopen master InduSoft driver supports many CANopen master functions for applying CANopen protocol by InduSoft SCADA software. By means of this driver, you don't need to have the complex and abstruse background knowledge of the CANopen. Only few simple steps can finish the communication between your PC and the remote CANopen devices.

- Communicates with the multiple I-7565-CPM (multi-port) and PISO-CPM100 series modules at the same time
- Auto-detect CANopen slave devices and monitoring I/O data
- NMT: Master
- CANopen Version: DS-301 v4.02
- Slave nodes support 1 ~ 127
- Support Guarding and Heartbeat protocol
- Support EMCY and SYNC protocol
- Provide dynamic PDO mapping functions
- Support SDO segment protocol

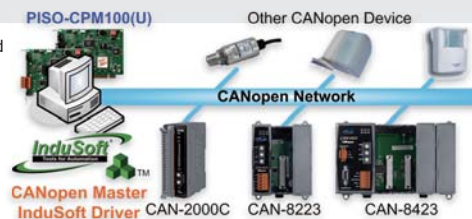

▶▶▶▶ CANopen Master LabVIEW Driver for PISO-CPM100U and I-7565-CPM

CANopen Master LabVIEW Driver

To implement CANopen communication by NI LabVIEW software, We provide a set of CANopen components in the LabVIEW driver. You only need to have the basic knowledge of the CANopen protocol. Then, through few simple steps can finish the communication between your PC and the remote CANopen devices.

- NMT: Master
- CANopen Version: DS-301 v4.02
- Slave nodes support 1 ~ 127
- Error Control: Support Guarding protocol
- Support EMCY and SYNC protocol
- Provide dynamic PDO functions
- Support SDO segment and block protocol
- Driver support Windows 98/ME/NT/2K/XP



5.4. DeviceNet Introduction & Products

Introduction

DeviceNet based on the CAN bus is one of the world's leading device-level networks for industrial automation. In fact, more than 40% of end users surveyed by independent industry analysis report choose DeviceNet over other networks.

ICP DAS has been developing CAN-based DeviceNet protocol products for several years, include PCI interface cards, gateways, DeviceNet IOs and DeviceNet modules for ICP DAS's PACs, XPAC/WinPAC/ViewPAC/LinPAC/iPAC series main control unit. We also help customers resolving various DeviceNet network technology problems. In addition, we can provide DeviceNet solutions for users. ICP DAS also holds DeviceNet conferences, exhibitions and training courses all over the world.

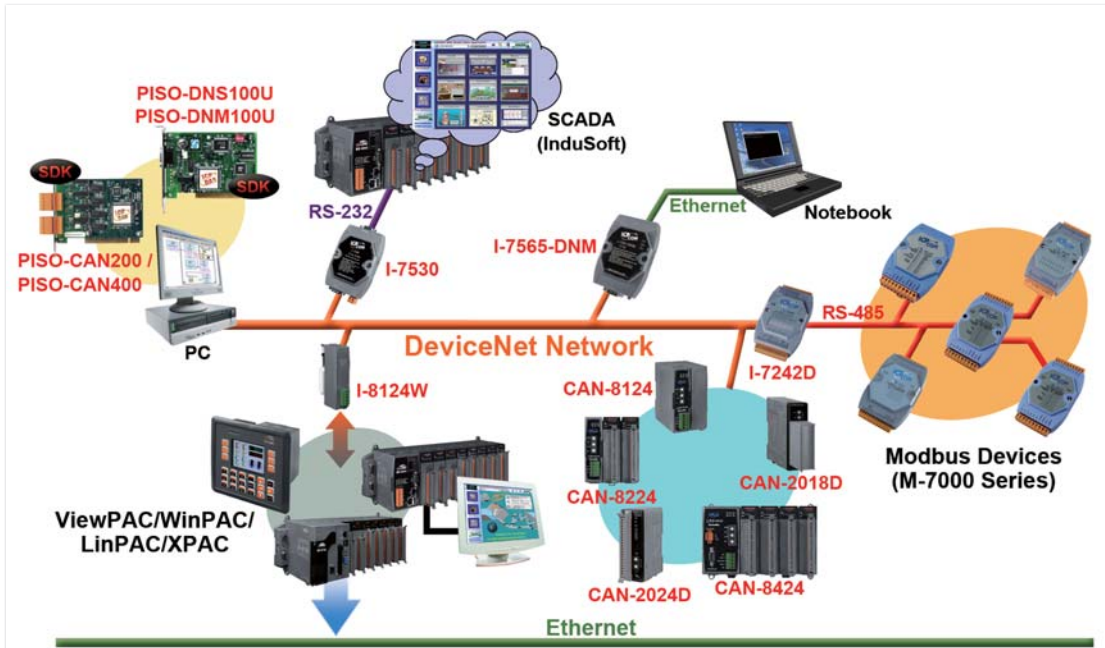

DeviceNet Features

- Comply with DeviceNet specification Volume I, Release 2.0 & Volume II, Release 2.0
- Support Group 2 Server and UCMM connection
- I/O Operating Modes: Poll, Bit-Strobe, Change of State/Cyclic
- Master series support Auto-Search function
- Master series provide input 512 bytes and output 512 bytes memory size for each slave
- Slave series support DeviceNet heartbeat and shutdown messages
- Slave series provide EDS file
- Selectable MAC ID (0 ~ 63) and baud rate (125, 250, 500 kbps)
- Built-in jumper or DIP switch for 120 Ω terminator resistor of CAN bus
- Built-in watchdog
- 3000 V_{DC} isolation for DC-to-DC
- 2500 V_{rms} isolation on CAN bus

Multi-Master Feature

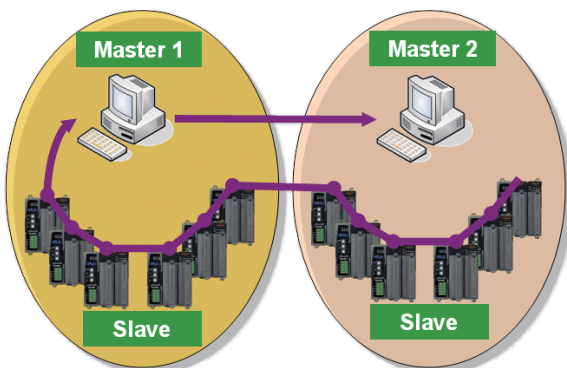

DeviceNet Master Utility

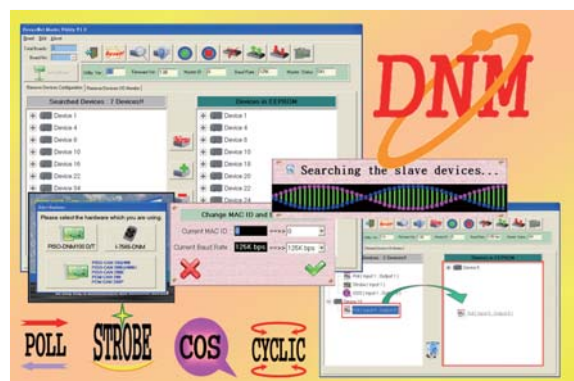

● Application Stories

▶▶▶▶ CVD/PECVD Semiconductor Machine

Product: I-8124W, CAN-8224, XP-8341

This system utilizes XP-8341 and I-8124W as the controlling center of the remote I/O devices. I-8124W provides DeviceNet master engine to collect the remote I/O data, including pneumatic valve "MKS 683" and Beckhoff DeviceNet I/O. XP-8341 exists an operating program to control the situation in the chamber. It is important to control the reacting time of the wafer in the chamber which have some kind of gas inside. After tuning timing and pressure parameter, this series equipment has been developed successfully and works in some semiconductor factories.

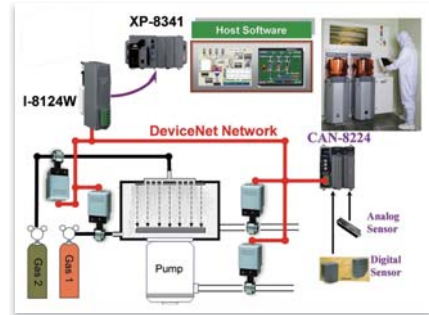

▶▶▶▶ LCD Glass Inspection System

Product: PISO-DNM100, CAN-2053D, CAN-2054D

The system is to check that the LCD glass is good or not. Nowadays, the LCD is larger and larger. They need a system to check glass instead of human. There exists a DeviceNet network to control all remote I/O devices. The PC and PISO-DNM100U acts the DeviceNet master and accesses the remote device like sensor, barcode, robot and etc. There exists inspection software in the PC. It would make the robot to load the glass into the equipment. Complete inspecting the glass, the software would record the result of the glass and unload the glass. This system really helps finding defect glass and improving the quality of the product.

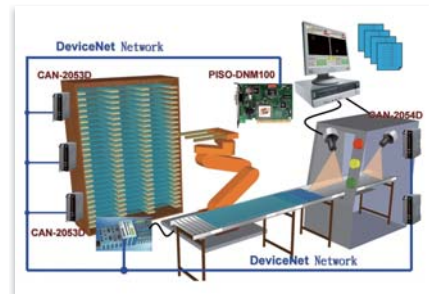

▶▶▶▶ IC Inspection Machine

Location: Hsinchu, Taiwan
Product: PISO-DNS100U

The IC inspection process is necessary for a good quality control. Though the PLC is cheap and stable, the IC inspection is a tough work for a PLC. The customer uses PC+ camera + PISO-DNS100U to do the IC inspection, and uses PLC to control the mechanism for rejecting the defective ICs. After finishing the inspection, the PC writes the result to the PISO-DNS100U. Because the PLC is a DeviceNet master, it can easily get the information from the PISO-DNS100U via DeviceNet network.

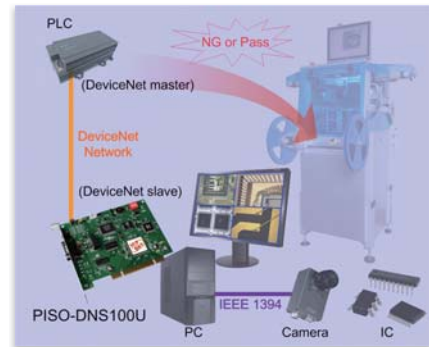

▶▶▶▶ Semiconductor Gas Detection System

Location: Kaohsiung, Taiwan
Product: WP-8441, I-8124W

In semiconductor factory, a lot of poison and inflammable gas are widely used in various processes. In order to keep the employees safe, the gas detectors are general applied to detect the concentration of the poison and inflammable gas in the semiconductor. The customer uses WP-8441+I-8124W to be the DeviceNet master for obtaining the concentration information from the gas detectors. Besides, the present employees can immediately understand the air quality via the touch screen of the WP-8441.

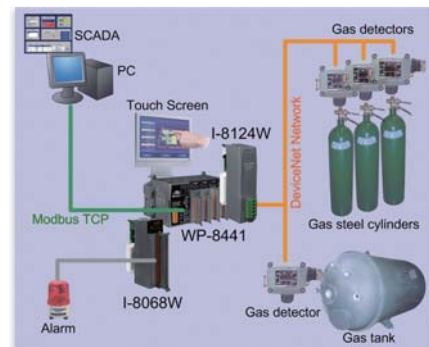

● Selection Guide

Model Name	DeviceNet Ports	Interface	Description	Page
DeviceNet Gateways				
GW-7243D	1	DeviceNet slave ↔ Ethernet/RS-232/RS-485	DeviceNet slave to Modbus TCP/RTU/ASCII master gateway	5-4-3
GW-7434D	1	DeviceNet master ↔ Ethernet/RS-232/RS-485	DeviceNet master to Modbus TCP/RTU slave gateway	
I-7241D	1	DeviceNet slave ↔ RS-485	DeviceNet slave to DCON master gateway	5-4-4
I-7242D	1		DeviceNet slave to Modbus RTU master gateway	
DeviceNet Modules				
I-7565-DNM	1	USB ↔ DeviceNet master	Intelligent USB to DeviceNet master converter	5-4-4
I-8124W	1	DeviceNet master, Backplane parallel bus	Intelligent DeviceNet master I-8K module	
I-87124	1	DeviceNet master, Backplane serial bus	Intelligent DeviceNet master I-87K module	
DeviceNet Boards				
PISO-DNS100U	1	DeviceNet slave, universal PCI bus	Intelligent DeviceNet slave universal PCI board	5-4-5
PISO-DNM100U	1	DeviceNet master, universal PCI bus	Intelligent DeviceNet master universal PCI board	

● Product Showcase

✓ DeviceNet Gateways

▶▶▶▶ DeviceNet Slave to Modbus TCP/RTU/ASCII Master Gateway

GW-7243D CR *NEW*

The GW-7243D is one of DeviceNet products in ICP DAS and it stands as a DeviceNet slave to Modbus TCP/RTU/ASCII master gateway device. In DeviceNet network, it functions as a "Group 2 Only Server" device. In Modbus network, GW-7243D sends request messages to access the Modbus slave as a master by DeviceNet object definition.

- Group 2 Only Server DeviceNet subscriber
- Support Explicit and Poll Connection
- User can select the Modbus RTU/ASCII protocol for each COM port
- Maximum support 4 Modbus TCP devices
- Support Modbus function codes: 0x01, 0x02, 0x03, 0x04, 0x05, 0x06, 0x0F and 0x10
- Maximum support 10 Modbus RTU/ASCII commands for each COM port
- Maximum support 5 Modbus TCP commands for each Modbus TCP device
- Maximum support 2048 channels DI, 2048 channels DO, 1024 channels AI and 1024 channels AO for each Modbus TCP device



▶▶▶▶ DeviceNet Master to Modbus TCP/RTU Slave Gateway

GW-7434D CR *NEW*

The GW-7434D is a DeviceNet master to Modbus TCP/RTU master gateway device, and is applied for connecting an existing DeviceNet network to Ethernet-base PLCs and PC-based system. The GW-7434D supports "Predefined Master/Slave Connection Set" and "Group 2 Only Server" functions.

- Supports maximum DeviceNet devices up to 63
- Supports one Poll, one Bit-Strobe, one COS or one Cyclic IO connection for each DeviceNet device
- Converts single Modbus TCP to multi Modbus RTU devices, setting by Utility
- Supports Modbus RTU to DeviceNet master, setting by Utility
- Predefined Master/Slave Connection Set
- Supports on-line adding device into and removing device from network
- Supports VxComm technique for every COM ports of controllers, setting by Utility
- Allows multi-client access simultaneously



▶▶▶▶ DeviceNet Slave to DCON Master Gateway

I-7241D CR

The I-7241D is the communication gateway between DeviceNet and DCON protocol. The DCON protocol is the communication protocol used by ICP DAS I-7000 and I-87K series modules. Through I-7241D, the DeviceNet master can build the DeviceNet network with the features of the I-7000 and I-87K series modules.

- Comply with DeviceNet specification volume I, release 2.0 & volume II, release 2.0
- I/O Operating Modes: Polling, Bit-Strobe, Change of State/Cyclic
- Watchdog inside
- Support Offline Connection Set, Device Heartbeat message and Device Shutdown message
- MAC ID & Baud: Configuration by utility or DeviceNet messages
- Support Predefined Master/Slave Connection Set (Group2 Only Server)
- 2500 V_{rms} photocoupler isolation on the CAN side
- Built-in jumper for 120 Ω terminator resistor of CAN bus
- Provide dynamic Assembly Objects mapping
- Product EDS file dynamically by utility
- Support max. 15 I-7000/I-87K I/O series modules
- 3 kV galvanic isolation
- 1 kV galvanic isolation



▶▶▶▶ DeviceNet Slave to Modbus RTU Master Gateway

I-7242D CR

I-7242D allows a master located on a DeviceNet network to enter into a dialogue with the slaves on a Modbus RTU network in DeviceNet network. It's a Group 2 Only Slave device, and supports "Predefined Master/Slave Connection Set".

- Comply with DeviceNet specification volume I, release 2.0 & volume II, release 2.0
- I/O Operating Modes: Polling, Bit-Strobe, Change of State/Cyclic
- Watchdog inside
- Support Offline Connection Set, Device Heartbeat message and Device Shutdown message
- Product EDS file dynamically by utility
- 1 kV galvanic isolation
- Support Predefined Master/Slave Connection Set (Group2 Only Server)
- 2500 V_{rms} photocoupler isolation on the CAN side
- Built-in jumper for 120 Ω terminator resistor of CAN bus
- Provide dynamic Assembly Objects mapping
- Allow to configure Explicit Message by using Modbus RTU protocol
- Support max 10 Modbus RTU series modules
- Device Shutdown message



✔ DeviceNet Modules

▶▶▶▶ Intelligent USB to DeviceNet Master Converter

I-7565-DNM CR **NEW**

The I-7565-DNM is a convenient DeviceNet master solution of the USB interface. It can be powered by the USB interface, therefore, no other power is needed. The I-7565-CPM supports Group 2 and UCMM functions to communicate with the slave devices. It can easily control/configure DeviceNet slave nodes via PC.

- Comply with DeviceNet specification volume I, release 2.0 & volume II, release 2.0
- I/O Operating Modes: Polling, Bit-Strobe, Change of State/Cyclic
- Built-in watchdog
- Provide on-line adding device into and removing device from network
- Provide C/C++ function libraries and demos
- Support Predefined Master/Slave Connection Set (Group2 Only Server)
- 2500 V_{rms} photocoupler isolation on the CAN side
- Built-in jumper for 120 Ω terminator resistor of CAN bus
- Support UCMM function
- Support auto-scan slave device function
- Auto-reconnect when the connection is broken
- 3 kV galvanic isolation



▶▶▶▶ Intelligent DeviceNet Master I-8K Module

I-8124W CR **NEW**

The I-8124W is a high price performance solution of the DeviceNet applications. It plays the role of a DeviceNet master device on the DeviceNet network. The I-8124W supports Group 2 and UCMM functions simultaneously. It can be installed in ViewPAC, WinPAC or XPAC series PACs for expanding a DeviceNet master interface. Because of the features of the high performance and flexibility, the I-8124W is popularly applied in the industrial automation, building automation, vehicle, and embedded control network. Inside the I-8124W, there is a complete DeviceNet protocol for processing the DeviceNet information. Users can easily access the slave device via the I-8124W without the complex and abstruse DeviceNet protocol background knowledge.

- DeviceNet Version: Volume I & II, Release 2.0
- Baud Rate: 125 K, 250 K, 500 K
- I/O Operating Modes: Poll, Bit-Strobe, Change of State/Cyclic
- Support auto-search slave device function
- Support auto-detect Group 2 and UCMM device
- Status LED: RUN, MS, NS
- Programmable Master MAC ID and Baud Rate
- Support Group 2 and UCMM connection
- I/O Length: 512 bytes max. (Input/Output) per slave
- Slave Node: 63 nodes max.
- Support on-line adding and removing devices
- Auto-reconnect when the connection is broken



▶▶▶▶ Intelligent DeviceNet Master I-87K Module

I-87124 CR

The I-87124 represents an economic solution of the DeviceNet applications and is a DeviceNet master device on the DeviceNet network. It supports Group 2 and UCMM functions to communicate with the slave devices. Through the I-87124, the WinPAC, LinPAC, XPAC and iPAC series PACs can easily expand a DeviceNet master interface.

- DeviceNet Version: Volume I & II, Release 2.0
- Baud Rate: 125 K, 250 K, 500 K
- I/O Operating Modes: Poll, Bit-Strobe, Change of State/Cyclic
- Support auto-search slave device function
- Support auto-detect Group 2 and UCMM device
- Status LED: RUN, MS, NS
- Programmable Master MAC ID and Baud Rate
- Support Group 2 and UCMM connection
- I/O Length: 512 bytes max. (Input/Output) per slave
- Slave Node: 63 nodes max.
- Support on-line adding and removing devices
- Auto-reconnect when the connection is broken



 **DeviceNet Boards**

Intelligent DeviceNet Slave Universal PCI Board

PISO-DNS100U CR *NEW*

The PISO-DNS100U provides the completed DeviceNet slave functions according to the DeviceNet Group 2 only server. It lets the PC play the role of the DeviceNet slave, and supports max. 10 slaves. Through the great computing power of the PC, the complex image process or control algorithm can be easily finished.

OS Support: Windows 2K/XP/Vista

- Universal PCI board, supports both 5 V and 3.3 V PCI bus
- Programmable Slave MAC ID and baud rate
- Support Group 2 only Server
- I/O Length: 512 bytes max. (Input/Output) per slave
- Not Support UCMM
- DeviceNet Version: Volume I & II, Release 2.0
- Baud Rate: 125 k, 250 k, 500 kbps
- I/O Modes: Poll, Bit-Strobe, Change of State/Cyclic
- Slave Node: Max. 10 nodes inside the board
- LED: Status, ERR

PISO-DNS100U-D



PISO-DNS100U-T

Intelligent DeviceNet Master Universal PCI Board

PISO-DNM100U CR *NEW*

The PISO-DNM100U has completed DeviceNet master functions according to the DeviceNet Group 2 only client. With the built-in 80186, 80 MHz CPU, this card can be applied in high transmission DeviceNet applications.

OS Support: Windows 2K/XP/Vista

- Universal PCI board, supports both 5 V and 3.3 V PCI bus
- Support Predefined Master/Slave Connection Set (Group 2 only server)
- 2500 V_{rms} photocoupler isolation on the CAN side
- Built-in jumper for 120 Ω terminator resistor of CAN bus
- Support UCMM function
- Support auto-scan slave device function
- Auto-reconnect when the connection is broken
- Comply with DeviceNet specification volume I, release 2.0 & volume II, release 2.0
- I/O Operating Modes: Polling, Bit-Strobe, Change of State/Cyclic
- Built-in watchdog
- Provide on-line adding device into and removing device from network
- 3 kV galvanic isolation

PISO-DNM100U-D



PISO-DNM100U-T

DeviceNet Software

Model Name	Description	Page
Compact DeviceNet Master Library	DeviceNet master Library for PISO-CAN/PEX-CAN/PCM-CAN series CAN boards	5-4-5
DeviceNet Master Utility	DeviceNet master utility for ICP DAS DeviceNet master devices	5-4-6
DeviceNet Master InduSoft Driver	DeviceNet master InduSoft driver for I-8124W, PISO-DNM100U and I-7565-DNM devices	5-4-6
DeviceNet Master LabVIEW Driver	DeviceNet master LabVIEW driver for PISO-CPM100U and I-7565-DNM	5-4-6

DeviceNet Master Library for PISO-CAN/PEX-CAN/PCM-CAN Series CAN Boards

Compact DeviceNet Master Library

The ICP DAS DeviceNet Master Library (DLL functions) for Windows and Linux OS provides users to establish DeviceNet network rapidly by Master/Slave connection model. It supports PISO-CAN/PEX-CAN/PCM-CAN series CAN cards. Owing to this library, you can develop various DeviceNet.

- DeviceNet Version: Volume I & II, Release 2.0
- Programmable master MAC ID and baud rate
- Baud Rate: 125 k, 250 k, 500 kbps
- Support Group 2 and UCMM connection
- I/O Operating Modes: Poll, Bit-Strobe, Change of State/Cyclic
- I/O Length: 512 bytes max. (Input/Output) per slave
- Slave Node: 63 nodes max.
- Support auto-search slave device function
- Support on-line adding and removing devices
- Support auto-detect Group 2 and UCMM device
- Auto-reconnect when the connection is broken

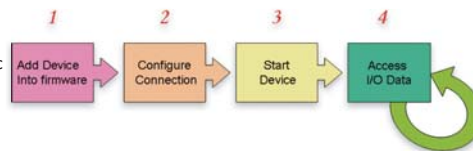

▶▶▶▶ DeviceNet Master Utility for ICP DAS DeviceNet Master Devices

DeviceNet Master Utility

The DNM Utility, a DeviceNet master tool for all ICP DAS master interfaces, is helpful for building the DeviceNet applications. It provides the functions for searching and diagnosing all devices in the DeviceNet network. After configuring the I/O connection, the information would be saved into the DeviceNet master hardware.

- Selectable baud rate and master MAC ID
- Search all the DeviceNet slaves if necessary
- Control and monitor the I/O status of all DeviceNet slaves
- Function for importing and exporting the slave information
- Allow to update the firmware of the PISO-DNM100U and I-8124W
- Support Group 2 and UCMM slave devices
- Easy to use with the graphic human interface
- Support PISO-CAN/PEX-CAN/PCM-CAN series CAN cards, PISO-DNM100U, I-8124W, and I-87124W master interface



▶▶▶▶ DeviceNet Master InduSoft Driver for I-8124W, PISO-DNM100U and I-7565-DNM Devices

DeviceNet Master InduSoft Driver

In order to apply the DeviceNet communication by InduSoft software, ICP DAS provides a set of the DeviceNet components in the InduSoft driver. By means of this driver, you don't need to have the complex and abstruse background of the DeviceNet protocol. Only few simple steps can finish the communication between your PC and the remote DeviceNet devices.

- Integrates with InduSoft Web Studio SCADA
- A Tag supports max. 4 bytes data length
- Communicates with the Multiple I-7565-DNM (multi-port) and PISO-DNM100U series modules at the same time
- Programmable MAC ID
- Auto-detect DeviceNet slave devices and supports DeviceNet I/O monitor
- Support Group 2 and UCMM devices
- Selectable data rates (baud): 125 k, 250 k, 500 kbps



▶▶▶▶ DeviceNet Master LabVIEW Driver for PISO-CPM100U and I-7565-DNM

DeviceNet Master LabVIEW Driver

In order to apply the DeviceNet communication by NI LabVIEW software, ICP DAS provides a set of the DeviceNet components in the LabVIEW driver. The LabVIEW driver includes a configuration utility to configure the ICP DAS's DeviceNet hardware in your PC. Through this tool, you can use LabVIEW to finish your DeviceNet application quickly and conveniently.

- NI LabVIEW Software version 7.0 or later
- Auto detecting DeviceNet slave devices and DeviceNet I/O monitor
- Programmable MAC ID
- Provide hardware configuration tool
- Support UCMM capable devices
- Selectable data rates (baud): 125 k, 250 k, 500 k
- Support the Predefined Master/Slave Connection Set

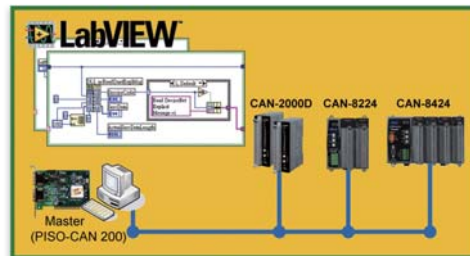

5.5. J1939 Introduction & Products

• Introduction

SAE J1939 is the vehicle bus standard for communication and diagnostics among vehicle components, originally by the car and heavy duty truck industry in the United States. Because of the success of applying in vehicles, J1939 has become the accepted industry standard and the vehicle network technology of choice for off-highway machines in applications such as construction, material handling, and forestry machines. It is a higher-layer protocol based on Controller Area Network (CAN), which provides serial data communications between microprocessor systems (ECU) in any kind of heavy duty vehicles. The messages exchanged between these units can be the vehicle road speed, torque control message from the transmission to the engine, oil temperature, and so forth.

All J1939 packets contain 8 bytes of data and a standard header which contains an index called PGN (Parameter Group Number), which is embedded in the message's 29-bit identifier. A PGN identifies a message's function and associated data. J1939 attempts to define standard PGNs to encompass a wide range of automotive, agricultural, marine and off-road vehicle purposes. A range of PGNs (00FF0016 through 00FFFF16, inclusive) is reserved for proprietary use. PGNs define the data which is made up of a variable number of SPN elements defined for unique data. For example, there exists a predefined SPN for engine RPM.

J1939 uses three methods to communicate over the CAN bus. Destination specific communications use the PDU1 (Protocol Data Unit 1) format to send and receive data. The PDU1 format allows a message to be directed to the specific ECU (CAN Node). The destination address is included in the PDU1 CAN frame. Broadcast Communications use the PDU2 (Process Data Unit 2) format to send a message to multiple nodes. The PDU2 message format identifies a message number versus a node number. In this case, each node monitor the CAN bus for specific message predefined in the node configuration, and drop other messages if useless. For example a display unit may ignore all other messages until it monitors the interesting data, such as Fuel Temperature and Fuel Pressure.

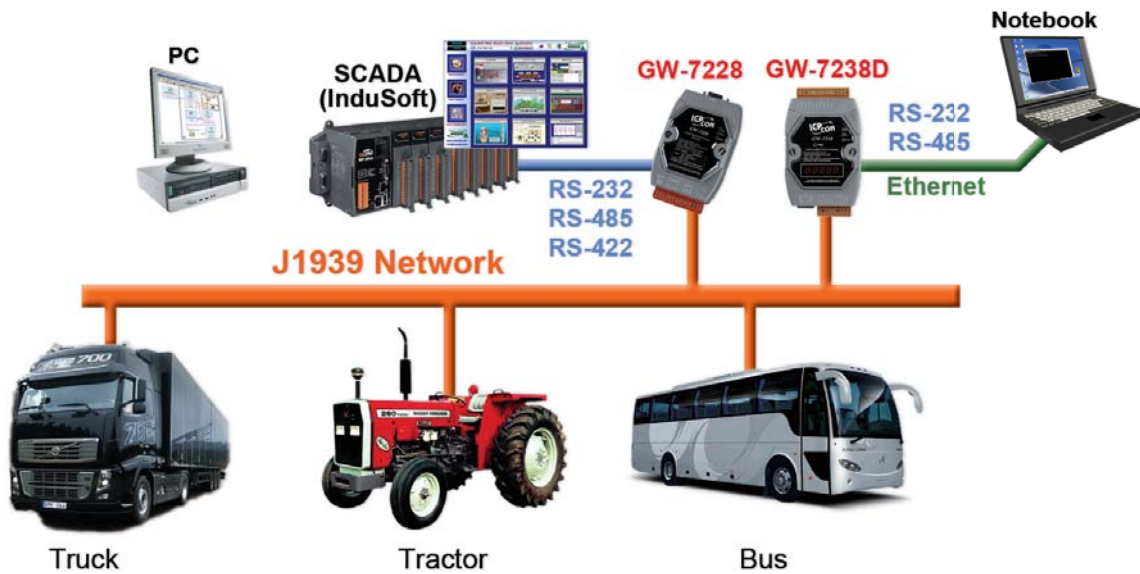

J1939 Features

- Higher-layer protocol based on CAN bus
- The speed is nearly always 250 kbit/s
- Based on CAN 2.0B specification
- Used in heavy-duty vehicles
- Peer-to-peer and broadcast communication
- Up to 1785-byte data length defined in Transport protocols
- Network management
- Definition of parameter groups

Application Layer	DeviceNet, CANopen J1939...etc
Object Layer	Message Filtering, Message and Status Handling
Transfer Layer	Fault Confinement, Message Framing and Signaling, Message Validation, Arbitration, Error Detection, Transfer Rate and Timing
Physical Layer	Signal Level and Bit Representation, Transmission Medium

CAN bus application layers

● Applications

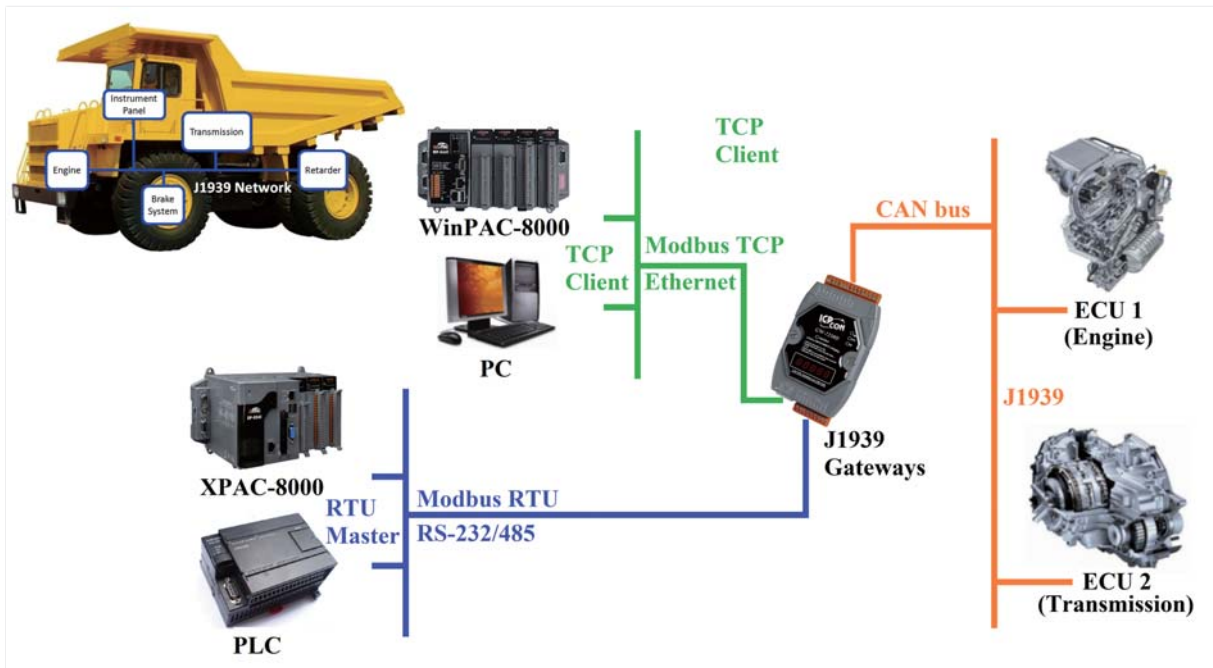

● Selection Guide

Model Name	Interface	Description	Page
J1939 Gateways			
GW-7228	J1939 ↔ Modbus RTU Slave	J1939 to Modbus RTU slave gateway	5-5-2
GW-7238D	J1939 ↔ Modbus TCP Server/RTU Slave	J1939 to Modbus TCP Server/RTU slave gateway	

● Product Showcase

J1939 Gateways

▶▶▶▶ J1939 to Modbus RTU Slave Gateway

GW-7228 CR **NEW**

The GW-7228 is a solution that provides a protocol conversion between J1939 and Modbus RTU. For J1939 network, the GW-7228 supports PDU1, PDU2, broadcast and destination specific type of J1939 messages. From the view of Modbus RTU network, the GW-7228 is a Modbus RTU slave to reply the request from Modbus RTU master.

- Provide PWR/J1939/MODBUS indication LEDs
- Watchdog inside
- J1939 Transport Protocol for transmission and reception of large messages (9 - 1785 bytes)
- Support BAM of Connection Management Message
- Support RS-232, RS-485 and RS-422 interfaces
- Configurable for Modbus Network ID (1 ~ 250)
- Built-in jumper to select 120 Ω terminal resistor
- Transmission and reception of all types of J1939 messages, including PDU1, PDU2, broadcast and destination specific
- Network addresses management
- Support Modbus RTU slave protocol



▶▶▶▶ J1939 to Modbus TCP Server/RTU Slave Gateway

GW-7238D CR **NEW**

The GW-7238D is a gateway that provides conversion between J1939 and Modbus TCP/RTU protocol. For J1939 network, the GW-7238D supports PDU1, PDU2, broadcast and destination specific type of J1939 messages. For Modbus TCP/RTU network, the GW-7238D is a Modbus TCP server/RTU slave to reply the request from Modbus TCP client/RTU master.

- Provide PWR/J1939/MODBUS indication LEDs
- Watchdog inside
- J1939 Transport Protocol for transmission and reception of large messages (9 - 1785 bytes)
- Support BAM of Connection Management Message
- Supports RS-232, RS-485 and Ethernet interfaces
- Configurable for Modbus Network ID (1 ~ 250)
- Built-in jumper to select 120 Ω terminal resistor
- Transmission and reception of all types of J1939 messages, including PDU1, PDU2, broadcast and destination specific
- Network addresses management
- Supports Modbus TCP server/RTU slave protocol
- Allows 5 Modbus/TCP clients' simultaneous accesses



5.6. PROFIBUS Introduction & Products

Introduction

PROFIBUS (PROCESS FIELD BUS) which is anchored in the international standards IEC 61158 and IEC 61784, is an open, digital communication system with a wide range of applications, particularly in the fields of factory and process automation. It is suitable for both fast, time-critical applications and complex communication tasks. ICP DAS provides a lot PROFIBUS DP products and help the user develop PROFIBUS application system easily. We have been developing and studying PROFIBUS DP for years. ICP DAS will always secure user's industrial safety and stable automation system as our mission.

These fieldbus solutions also support multi-drop networking of devices on a single twisted-pair cable providing substantial cost savings in:

- Reduced wiring
- Commissioning and installation
- Plant operations and improved quality
- Maintenance

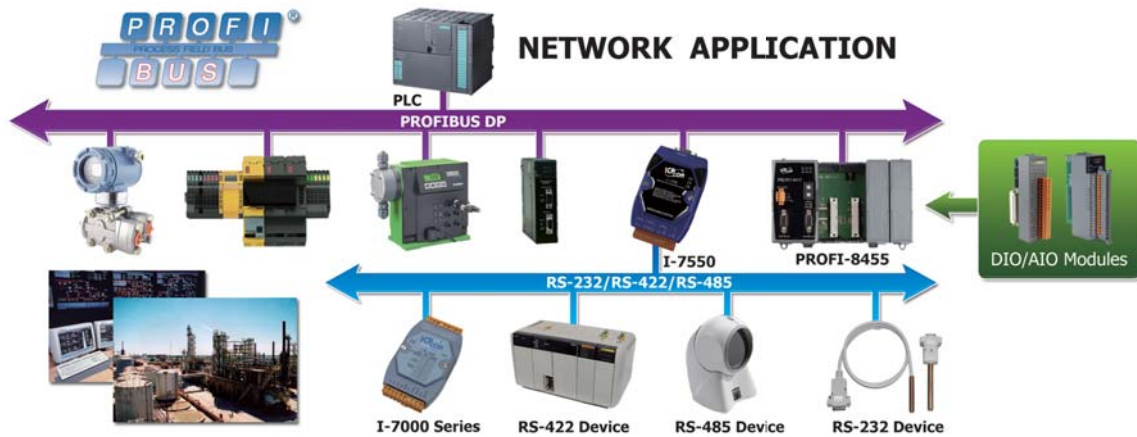

PROFIBUS Features

- Baud rate up to 12 Mbit/s
- Maximum 244 bytes input and 244 bytes output per slave
- Slave configuration and parameters are set from the master side by GSD file
- Allow multi-master system
- Fast cyclic data communication between master and slave
- 124 slaves can be put in data exchange
- 32 stations on one segment

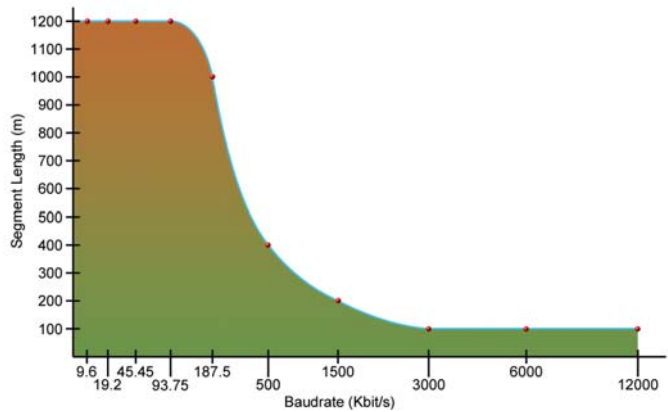

Application Stories

Vessel Propulsion Control and Monitor System

Product: GW-7552

The propulsion system is the most important and complex part of one ocean fishing vessels. It is composed of many electronic devices to control and monitor the engine speed, cooling system, residual fuel content, exhaust gas temperature, engine oil pressure, and so forth. Each of these devices may be handled by several PLCs via the different communication interfaces. In order to integrate the information from these devices, the customer uses the GW-7552 for data-exchange between the Siemens PLC and the Modbus PLC. Therefore, the HMI can collect and configure the important parameters of the propulsion systems quickly and easily through the GW-7552.

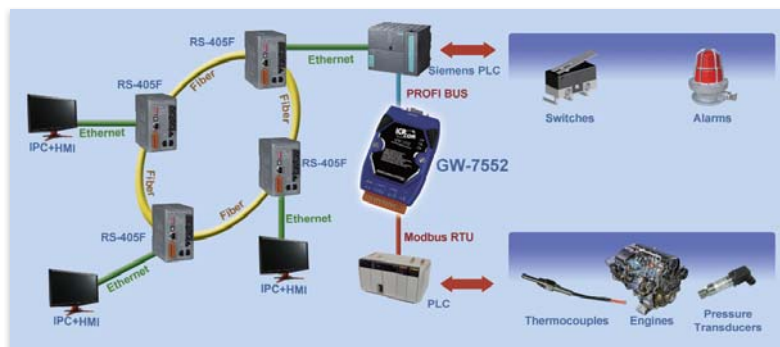

● Selection Guide

Model Name	PROFIBUS Ports	Interface	Description	Page
PROFIBUS Repeater				
PROFI-2510	1	PROFIBUS DP ↔ PROFIBUS DP	Isolated PROFIBUS repeater	5-6-2
PROFIBUS Converters				
PROFI-2541	1	PROFIBUS DP ↔ Fiber	PROFIBUS to fiber converter	5-6-3
I-7550	1	PROFIBUS DP slave ↔ RS-232/RS-422/RS-485	PROFIBUS to RS-232/RS-422/RS-485 converter	
PROFIBUS Gateways				
GW-7552	1	PROFIBUS DP slave ↔ RS-232/RS-422/RS-485	PROFIBUS slave to Modbus RTU gateway	5-6-4
GW-7553	1	PROFIBUS DP slave ↔ Ethernet/RS-232	PROFIBUS slave to Modbus TCP/RTU gateway	
GW-7557	1	PROFIBUS DP slave ↔ HART master	PROFIBUS slave to HART master gateway	

● Product Showcase

PROFIBUS Repeater

▶▶▶▶ Isolated PROFIBUS Repeater

PROFI-2510 CR *Available soon*

The PROFI-2510 is an PROFIBUS repeater adaptor. It can regenerate the electrical signal arriving on the bus line and retransmits it, so trouble in the line are mostly avoided. At the same time, it electrically isolates the receive lines from the transmit lines.

- Detect transmission rate (9.6 kbps ~ 12000 kbps) on PROFIBUS automatically
- Can be used as a bus extension or spur line
- System expansion
- Wide range of power input (10 ~ 30 Vdc) and operating temperature (-25 °C ~ +75 °C)
- No additional space needed in the cabinet
- Increases the number of nodes
- Provide status LEDs
- 2500 Vrms isolation protection on PROFIBUS side
- 4 kV Contact ESD protection for any terminal

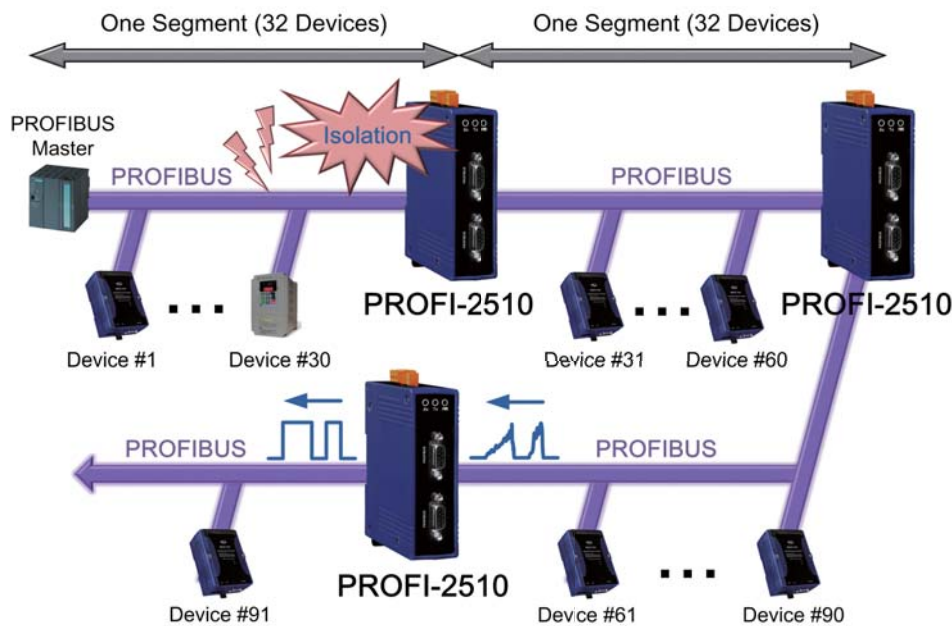

 PROFIBUS Converters

▶▶▶ PROFIBUS to Fiber Converter

PROFI-2541 CR *Available soon*

The PROFI-2541 is a PROFIBUS to fiber optic converter that secures data transmission through the fiber to provide immunity from EMI/RFI interference. It is used for PROFIBUS point-to-point connections and suited for protecting the transmission from electrical exposure, surges or chemical corrosion.

- Detect transmission rate (9.6 kbps ~ 3000 kbps) on PROFIBUS automatically
- Wave Length: 850 nm
- DIN-Rail Mounting
- 4 kV Contact ESD protection for any terminal
- Fiber Port: ST (Multi-mode)
- Provide status LEDs
- 2500 Vrms isolation protection on PROFIBUS side
- Wide range of power input (10 ~ 30 Vdc) and operating temperature (-25 °C ~ +75 °C)

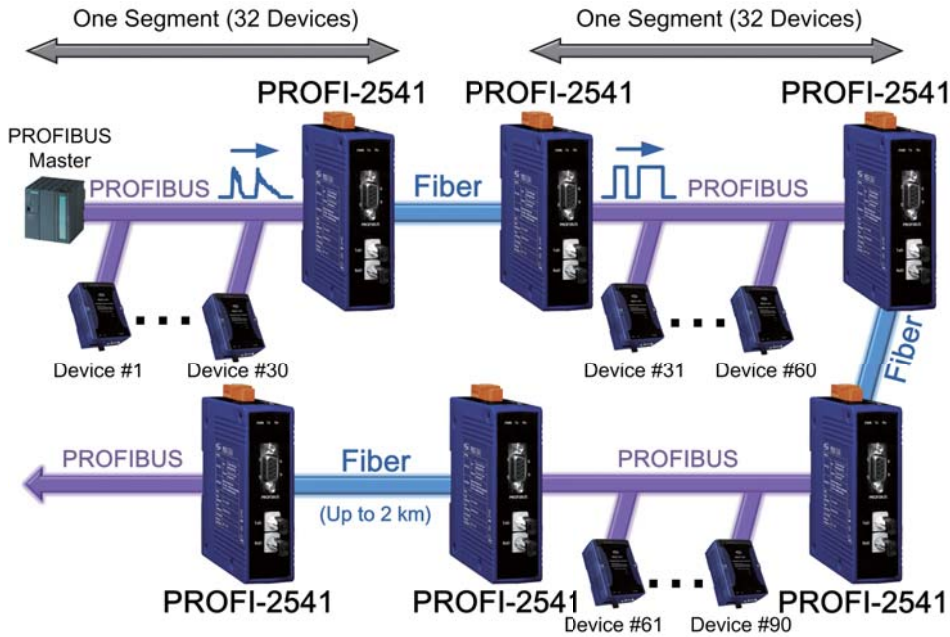

▶▶▶ PROFIBUS to RS-232/RS-422/RS-485 Converter

I-7550 CR

The I-7550 convert is specially designed for the slave device of PROFIBUS DP protocol. It offers RS-232, RS-422, and RS-485 communication ports. With the hybrid design of the COM1, you can choose one type of this COM port for implement. Through the I-7550, applying RS-232/RS-422/RS-485 devices into PROFIBUS network is getting easily.

- Protocol & Hierarchy: DP-V0 Slave
- 128 bytes max. input data length
- 128 bytes max. output data length
- Support several kinds of baud for COM1 from 1.2 kbps ~ 115.2 kbps
- Detect transmission rate (9.6 kbps ~ 12000 kbps) on PROFIBUS automatically
- PROFIBUS address 0 ~ 126 set by DIP switch
- Network Isolation Protection: 2500 Vrms high speed iCoupler
- 3000 Vdc isolation protection on PROFIBUS side



PROFIBUS Gateways

▶▶▶▶ PROFIBUS Slave to Modbus RTU Gateway

GW-7552 CR

The GW-7552 gateway is a PROFIBUS DP slave. It allows the PROFIBUS master to access the Modbus RTU devices. In the Modbus network, the GW-7552 can be a master to access the Modbus slaves, or be a slave to provide the data from the PROFIBUS master. The flexible design lets the GW-7552 widely applying in the many applications.

- Protocol & Hierarchy: DP-V0 Slave
- 128 bytes max. input data length
- 131 bytes max. output data length
- Support RTU and ASCII Modbus format
- Support several kinds of baud for COM1 from 2.4 to 115.2 kbps
- Detect transmission rate (9.6 kbps ~ 12000 kbps) on PROFIBUS automatically
- Support Modbus Master and Modbus Slave both mode
- PROFIBUS address 0 ~ 126 set by DIP switch
- Network Isolation Protection: 2500 Vrms high speed iCoupler
- 3000 Vdc isolation protection on PROFIBUS side



▶▶▶▶ PROFIBUS Slave to Modbus TCP/RTU Gateway

GW-7553 CR *NEW*

The GW-7553 is used for data-exchange between the Modbus TCP/RTU network and the PROFIBUS network. It provides not only the Modbus TCP client and server functions, but the Modbus RTU master and slave functions. Therefore, the GW-7553 can satisfy most of the applications of the data transfer between Modbus and PROFIBUS.

- Protocol & Hierarchy: DP-V0 & DP-V1 Slave
- Support one 10/100 Base-TX Ethernet port
- Support one RS-232 port (3-wire or 5-wire)
- 240 bytes max. output data length
- PROFIBUS address 0 ~ 126 set by DIP switch
- 3000 Vdc isolation protection on PROFIBUS side
- Detect transmission rate (9.6 kbps ~ 12000 kbps) on PROFIBUS automatically
- 240 bytes max. input data length
- Support Modbus TCP/RTU/ASCII master/slave protocol
- Network Isolation Protection: 2500 Vrms high speed iCoupler



▶▶▶▶ PROFIBUS Slave to HART Master Gateway

GW-7557 CR *Available soon*

The GW-7557 is designed for the slave device of PROFIBUS DP protocol. It allows the PROFIBUS master to access the HART slave devices. These HART devices may be a transmitter, an actuator, a current output device and so forth. Owing to the GW-7557, you can put the HART slave devices into PROFIBUS network very easily.

- Protocol: PROFIBUS DP-V0 slave
- 240 bytes max. input data length
- 240 bytes max. output data length
- Support HART Mode: point-to-point/multi-drop
- Support HART Short/Long frame
- 3000 Vdc isolation protection on PROFIBUS side
- Detect transmission rate (9.6 kbps ~ 12000 kbps) on PROFIBUS automatically
- PROFIBUS address 0 ~ 126 set by DIP switch
- Support 4 HART channels, each for max. 15 HART modules
- Network Isolation Protection: 2500 Vrms high speed iCoupler



● Accessories

Model Name	Description	Page
CNT-PROFI	PROFIBUS connector	5-6-4

PROFIBUS Connector

▶▶▶▶ PROFIBUS Connector

CNT-PROFI CR *NEW*

The CNT-PROFI connector is used for connecting a PROFIBUS node to the PROFIBUS line. It provides a plastic housing and integrates the terminating resistors. Owing to the CNT-PROFI connector, to install the PROFIBUS node in the PROFIBUS network would be more work quickly and easily.

- Built-in switch to select 120 Ω terminal resistor
- 2 cable entries
- Cable outlet: 90° cable outlet
- Connector: 9-Pin, D-Sub male connector
- Baud rate: 9.6 kbps ~ 12 Mbps
- Operation temperature: -25 °C ~ +75 °C
- Storage temperature: -30 °C ~ +80 °C
- Humidity: 10 ~ 90% RH, non-condensing



Installation



5.7. HART Introduction & Products

Introduction

HART Field Communications Protocol extends this 4 ~ 20 mA standard to enhance communication with smart field instruments. The protocol preserves the 4 ~ 20 mA signal and enables two-way digital communications to occur without disturbing the integrity of the 4 ~ 20 mA signal. Unlike other communication technologies, the HART protocol can maintain compatibility with existing 4 ~ 20 mA systems with a uniquely backward compatible solution.

Here are two main operational modes of HART instruments: analog/digital mode, and multi-drop mode.

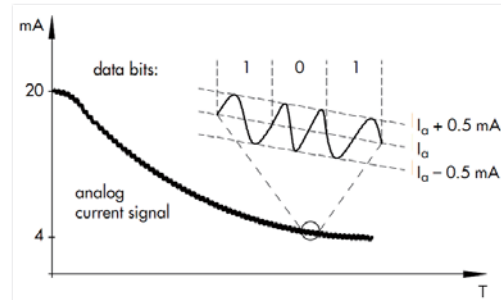

Peer-to-Peer Mode

The analog and digital signals can be communicated in this mode. Here the digital signals are overlaid on the 4 ~ 20 mA loop current. Both the 4 ~ 20 mA current and the digital signal are valid output values from the instrument. The polling address of the instrument is set to "0". Only one instrument can be put on each instrument cable signal pair.

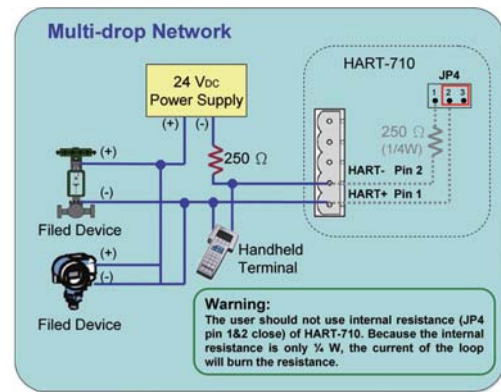
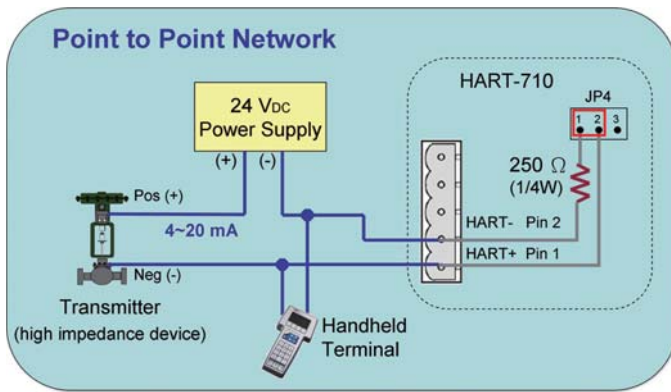

Multi-drop Mode (digital)

In this mode, only the digital signals are used. The analog loop current is fixed at 4 mA. In multi-drop mode it is possible to have up to 15 instruments on one signal cable. The polling addresses of the instruments will be in the range 1 ~ 15. Each meter needs to have a unique address.

HART Features

- Relatively easy to understand and use, the HART protocol provides access to the wealth of additional information (variables, diagnostics, calibration, etc.)
- HART is a no risk solution for enhanced field communication
- Risk reduction through a highly accurate and robust protocol
- Compatibility with standard 4 ~ 20 mA wiring
- Simultaneous transmission of digital data
- Increase Plant Availability
- Reduce Maintenance Costs
- Improve regulatory compliance

Application Stories

Wastewater Treatment Toll Collection System

Product: HART-710

The wastewater treatment is an important issue of the environment protection all over the world. During the process of manufacture and production, the wastewater is made, and needs to be processed by the wastewater treatment plants (WWTP). The customer from the WWTP needs to know the quantity of the draining wastewater from the factories, and charges proper tolls for treating the wastewater. Therefore, the HART-710, a HART master to Modbus slave gateway, is applied to integrate the information from the Siemens flow meters into the customer's HMI system. Through the HART-710, all of the flow meters will be regarded as one Modbus slave. The HMI system can use the built-in Modbus RTU communication mode to easily access the flow meters.

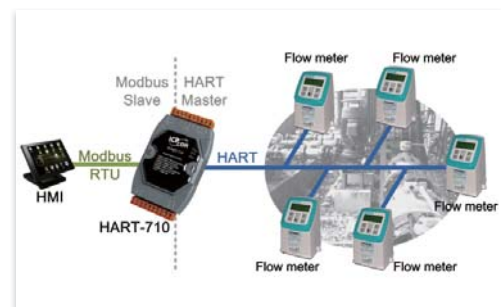

▶▶▶ Petrochemical GAS Pressure Detection System

Product: I-87H17W

The conveying pipes are everywhere in the petrochemical plants, and used for conveying the variety liquids and gases which may be poison and flammable. The situations of these liquids and gas must be presented and handled in the control center. The customer uses the WP-8841 with the touch screen to be the HMI and control system. On the WP-8441, there is an I-8064W and an I-87H17W. The I-87H17W is a HART AI module, and is applied for received the 8 ABB pressure transmitters which monitors the gas pressure through the pipes. This control system not only displays the gas pressure on the touch screen directly, but triggers the alarm while the gas pressure exceed the upper limitation.

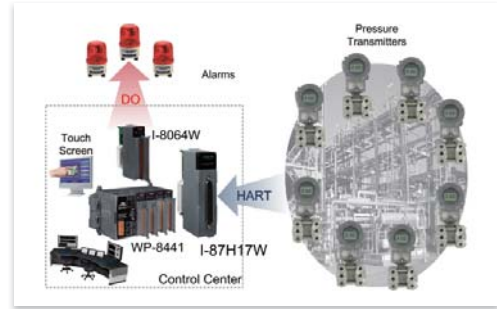

● Selection Guide

Model Name	HART Ports	Interface	Description	Page
HART Gateways				
HART-710	1	HART master ↔ RS-232/RS-422/RS-485	HART master to Modbus RTU/ASCII slave gateway	5-7-2
GW-7557	1	HART master ↔ PROFIBUS DP slave	PROFIBUS slave to HART master gateway	
HART Modules				
I-87H17W	1	HART master, 8 current inputs	8-ch current input HART master module	5-7-3
I-87H24W	1	HART master, 4 current outputs	4-ch current output HART master module	
HART Converters				
I-7567	1	HART master ↔ USB	USB to HART master converter	5-7-3
I-7570	1	HART master ↔ RS-232/RS-422/RS-485	HART to RS-232/RS-422/RS-485 converter	

● Product Showcase

HART Gateways

▶▶▶ HART Master to Modbus RTU/ASCII Slave Gateway

HART-710 CR **NEW**

The HART-710 is a HART master to Modbus slave gateway. It provides an economic solution for Modbus master device to access the HART slave devices. In order to diagnose and configure the HART network more easily, the HART-710 Utility tool HMI is given.

- Support HART Short/Long frame
- Support HART Burst mode
- Allow two HART masters
- Support the in point-to-point or multi-drop HART network mode
- Allow to connect with max. 15 HART modules
- Support Modbus RTU and ASCII format
- Modbus Function Code: 01, 02, 03, 04, 05, 06, 15 and 16
- Isolated COM1: 3-wire RS-232/RS-422/RS-485
- Built-in Watchdog
- DIN-Rail Mounting



▶▶▶ PROFIBUS Slave to HART Master Gateway

GW-7557 CR **Available soon**

The GW-7557 is designed for the slave device of PROFIBUS DP protocol. It allows the PROFIBUS master to access the HART slave devices. These HART devices may be a transmitter, an actuator, a current output device and so forth. Owing to the GW-7557, you can put the HART slave devices into PROFIBUS network very easily.

- Protocol: PROFIBUS DP-V0 slave
- 240 bytes max. input data length
- 240 bytes max. output data length
- Support HART Mode: point-to-point/multi-drop
- Support HART Short/Long frame
- 3000 Vdc isolation protection on PROFIBUS side
- Detect transmission rate (9.6 kbps ~ 12000 kbps) on PROFIBUS automatically
- PROFIBUS address 0 ~ 126 set by DIP switch
- Support 4 HART channels, each for max. 15 HART modules
- Network Isolation Protection: 2500 Vrms high speed iCoupler





HART Modules

▶▶▶▶ 8-ch Current Input HART Master Module

I-87H17W CR **NEW**

The I-87H17W is an 8-ch HART analog input module. It can measure 4 ~ 20 mA current and act as a HART master, allowing communication with HART field devices. Users can measure current directly without any external resistor. The I-87H17W adopts DCON protocol and can be used in WinPAC, ViewPAC, XPAC, LinPAC and iPAC series PAC.

- Support HART Short/Long frame
- Support HART Burst mode
- Allow two HART masters
- Support the in point-to-point or multi-drop HART network mode
- Allow to connect with max. 15 HART modules
- Support 4 ~ 20 mA current input
- 2-wire or 4-wire transmitters of HART
- Support DCON protocol
- Open wire detection
- 4 kV ESD protection and 2500 Vdc intra-module isolation



▶▶▶▶ 4-ch Current Output HART Master Module

I-87H24W CR **Available soon**

The I-87H24W is a 4-ch HART analog output module. It can output 4 ~ 20 mA current and be as a HART master, allowing communication with HART field devices. The I-87H24W supports DCON protocol defined by ICP DAS, and can be used in WinPAC, ViewPAC, XPAC, LinPAC and iPAC series PAC.

- Support HART Short/Long frame
- Support HART Burst mode
- Allow two HART masters
- Support the in point-to-point or multi-drop HART network mode
- Allow to connect with max. 15 HART modules
- Support 4 ~ 20 mA current output
- 2-wire transmitters of HART
- Support DCON protocol
- Open wire detection
- 4 kV ESD protection and 2500 Vdc intra-module isolation



HART Converters

▶▶▶▶ USB to HART Master Converter

I-7567 CR **NEW**

The USB interface is comprehensive applied in PCs and notebooks. In order to touch the users' requirements more closely, the I-7567 is presented. It is a USB to HART converter specially designed as the master device of HART protocol. Through it, users can easily access the HART network via USB port which is implemented as a virtual COM port on PCs or notebooks. Because the I-7567 is powered by the USB interface, the external power is not necessary. Moreover, the I-7567 provides the Utility tool which is helpful for diagnosing and configuring the HART network. If you would like to develop a HART network, the I-7567 will be a good tool to reduce your setup costs.

Features

- Support HART Short/Long frame
- Support HART Burst mode
- Allow two HART masters
- Support the in point-to-point or multi-drop HART network mode
- Allow to connect with max. 15 HART modules
- Provide selectable 250 Ω load resistor
- Compatible with USB 1.1 and 2.0 standards
- Powered by USB (external power is not necessary)
- Support firmware update via USB
- Provide utility tool for module configuration
- Built-in watchdog
- 4 kV ESD protection
- 3000 Vdc intra-module isolation

Utility Features

- Easily transmit/receive HART command for testing
- Provide HART device diagnostic information
- Provide module parameter configuration



▶▶▶▶ HART to RS-232/RS-422/RS-485 Converter

I-7570 CR **NEW**

The I-7570 is a Serial to HART converter specially designed as the master device of HART protocol. By using I-7570, the HART devices, such transmitters, actuators, gauges, meters, and the current output devices, can be easily integrated into the HMI/PLC/PC devices via serial port which may be RS-232/RS-422/RS-485 interface. In order to diagnose and configure the HART network more easily, the I-7570 Utility tool with friendly configuration interface is given. It is helpful for diagnosing and configuring the HART network. Through it, you can build a HART network more easily and quickly.

Features

- Support HART Short/Long frame
- Support HART Burst mode
- Allow two HART masters
- Support the in point-to-point or multi-drop HART network mode
- Allow to connect with max. 15 HART modules
- Provide selectable 250 Ω load resistor
- Isolated COM1: 3-wire RS-232/RS-422/RS-485
- Support firmware update via COM1
- Provide utility tool for module configuration
- Provide PWR/RUN/ERR LED indicators
- Built-in watchdog
- 4 kV ESD protection
- DIN-Rail Mounting

Utility Features

- Easily transmit/receive HART command for testing
- Provide HART device diagnostic information
- Provide module parameter configuration



5.8. EtherNet/IP Introduction & Products

• Introduction

EtherNet/IP is one of the open network standards, like DeviceNet and ControlNet. It is an industrial application layer protocol for industrial automation applications. EtherNet/IP uses all of the protocols of traditional Ethernet including the Transport Control Protocol (TCP), the Internet Protocol (IP) and the media access and signaling technologies. Building on standard Ethernet technologies means that EtherNet/IP will work transparently with all the standard Ethernet devices found today. EtherNet/IP application layer is based on the "Common Industrial Protocol" (CIP) which is used in both DeviceNet and ControlNet. This standard organizes networked devices as a collection of objects. It defines the access, behavior and extensions, which allow vastly different devices to be accessed using a common protocol. Building on these protocols, EtherNet/IP provides a seam-less integrated system from the Industrial floor to the enterprise network.

EtherNet/IP uses all the transport and control protocols of standard Ethernet including the Transport Control Protocol (TCP), the User Datagram Protocol (UDP), the Internet Protocol (IP) and the media access and signaling technologies found in off-the-shelf Ethernet technology. Building on these standard communication technologies means that EtherNet/IP works transparently with all the standard Ethernet devices found in today's market-place.

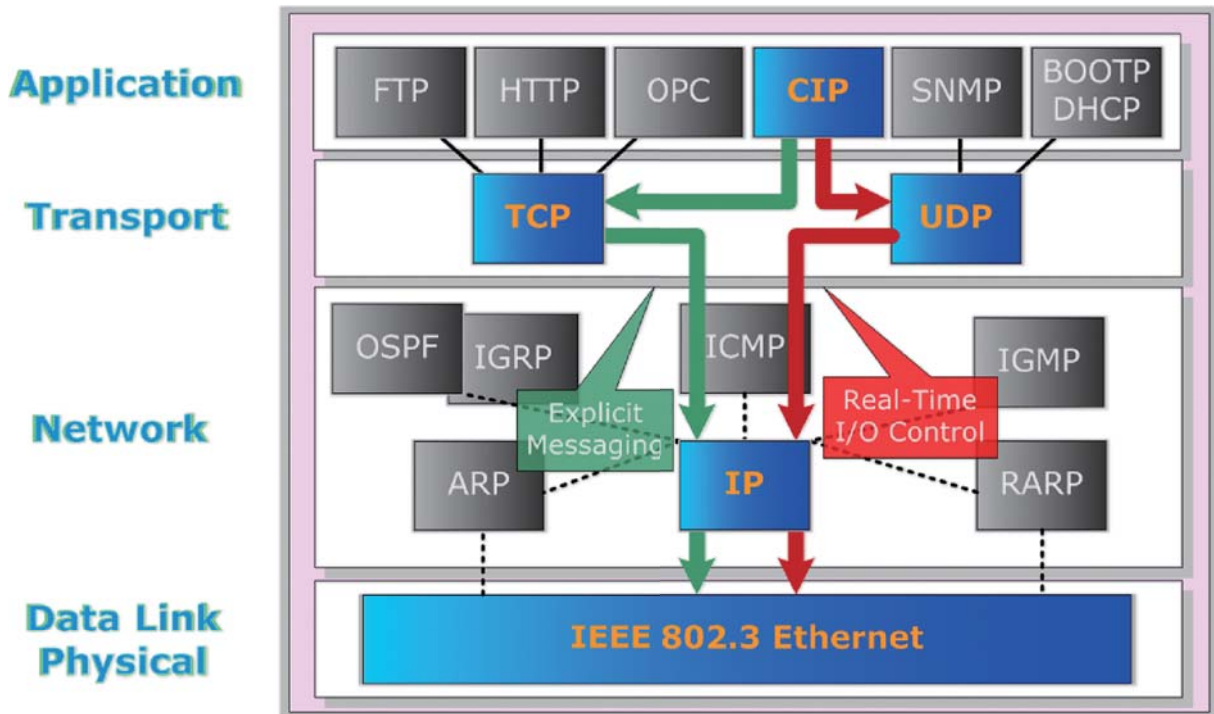

EtherNet/IP Features

- Offer Producer-Consumer service that enable users to control, configure and collect data.
- Uses existing IEEE standards for Ethernet physical layer and data link layer
- Provide flexible installation options leveraging commercially available industrial infrastructure products, including copper, fiber, fiber ring and wireless solutions.
- Provide robust physical layer options for industrial environments and includes the use of sealed RJ-45 and M12-4 D-coding connector.
- Compatible with general communication standards, including OPC, TCP/IP, HTTP, FTP, SNMP, DHCP.
- Use TCP port number 44818 for explicit messaging and UDP port number 2222 for implicit messaging
- Transfer of basic I/O data via UDP-based implicit messaging
- Uploading and downloading of parameters, programs and recipes via TCP
- Polled, cyclic and change-of-state monitoring via UDP
- One-to-one (unicast), one-to-many (multicast), and one-to-all (broadcast) communication via TCP

• Applications

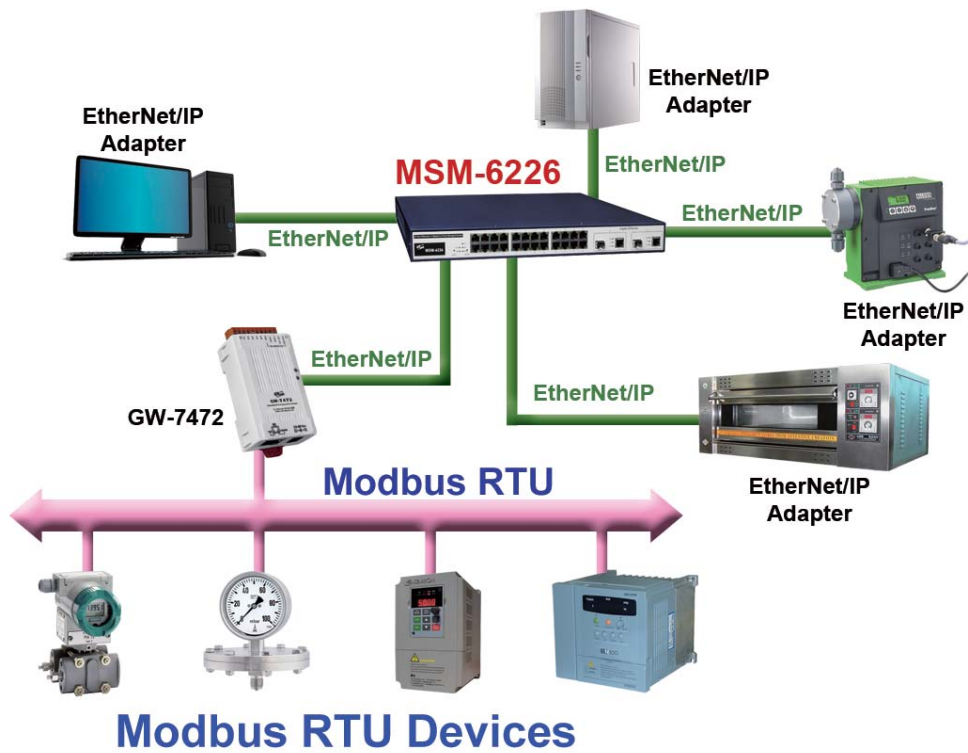
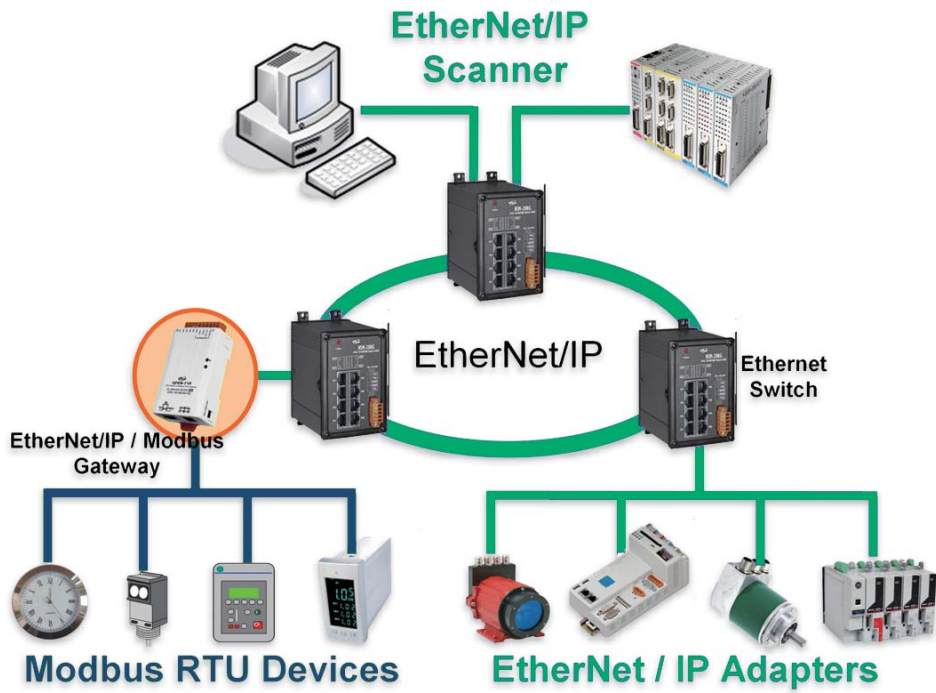

• Selection Guide

Model Name	EtherNet/IP Ports	Interface	Description	Page
Ethernet/IP Gateways				
GW-7472	1	EtherNet/IP adapter ↔ RS-485	EtherNet/IP adapter to Modbus RTU master gateway	5-8-3
MSM-6226	26	L2 Plus Fast Ethernet x 24 TP/SFP Gigabit Dual Media x 2	24-port L2 plus managed fast Ethernet switch + 2 TP/SFP gigabit dual media	

• Product Showcase

EtherNet/IP Gateways

▶▶▶▶ EtherNet/IP Adapter to Modbus RTU Master Gateway

GW-7472 CR **NEW**

The GW-7472 is a EtherNet/IP adapter to Modbus RTU master gateway. It converts a network of Modbus RTU slave devices to a single node of I/O on an EtherNet/IP network. In the EtherNet/IP network, through the GW-7472, the register data read from the Modbus RTU slave are presented as the input data of the EtherNet/IP scanner. The output data transmitted by an EtherNet/IP scanner is used for updating the register data of Modbus RTU slave device. The entire network of Modbus RTU slave devices appears to the EtherNet/IP scanner as a single node of EtherNet/IP adaptor.

- 10/100 Base-TX Ethernet, RJ-45 x 1 (Auto-negotiating, auto MDI/MDIX, LED Indicators)
- Supported EtherNet/IP I/O connection methods:
 - Transport and Trigger: Exclusive-Owner, Cyclic
 - Original to Target Type: POINT2POINT
 - Target to Original Type: POINT2POINT, MULTICAST
- Device Configuration Option: Custom software
- Address Configuration: DHCP, custom software
- Maximum number of Explicit Messaging connections: 6
- Supports ARP, TCP, UDP, ICMP, DHCP, BOOTP and TFTP protocols
- Maximum Modbus RTU slave data mapped to EtherNet/IP input data: 500 bytes
- Maximum EtherNet/IP output data mapped to Modbus RTU slave devices: 500 bytes
- Supported Modbus RTU Function Code 01, 02, 03, 04, 05, 06, 15, and 16
- Maximum data size per Modbus slave device: 240 bytes
- Maximum support 30 Modbus RTU slave devices
- Automatically RS-485 direction control
- Easy firmware update via Ethernet
- Powered by PoE (IEEE 802.3af, Class 1) or DC jack
- Tiny form-factor (Width x High x Depth = 52 mm x 95 mm x 27mm) and low power consumption
- Made from fire retardant materials (UL94-V0 Level)



▶▶▶▶ 24-port L2 Plus Managed Fast Ethernet Switch + 2 TP/SFP Gigabit Dual Media

MSM-6226 CR **NEW**

The MSM-6226, 24 Fast Ethernet + 2 Gigabit L2 Managed Switch, implemented 24 10/100 Mbps TP + 2 Gigabit dual media ports with TP/SFP (or GBIC), is a standard switch that meets all IEEE 802.3/u/x/z Gigabit, Fast Ethernet and Ethernet specifications. The switch can be managed through RS-232 serial port via direct connection, or through Ethernet port using Telnet or Web-based management unit, associated with SNMP agent. With the SNMP agent, the network administrator can logon the switch to monitor, configure and control each port activity in a friendly way. The overall network management is enhanced and the network efficiency is also improved to accommodate high bandwidth applications.

- 2 Dual Media for Flexible Fiber Connection
- Port Mirroring helps supervisor monitoring network
- Support Q-in-Q (Double-tag)
- IEEE802.1Q tag-base VLAN for performance & security and 4094 VLAN entries
- IEEE802.1X Access Control improve network security
- IEEE802.1D Compatible, IEEE802.1w Rapid Spanning Tree & IEEE802.1s Multiple Spanning Tree
- Unknown Unicast/Broadcast/Multicast storm control
- Multicast VLAN management for IPTV
- IP-MAC-Port binding for LAN security
- QCL Based on Application traffic for QoS and rate limitation management
- Support IGMPv3 snooping and IGMP Proxy
- Support DHCP snooping (DHCP option 82)
- ACL Based on Ethernet Type/ARP/IPv4 for packets permit or deny, rate limitation and port copy
- Support "power saving" for Green Ethernet requirement
- Support LLDP (Link Layer Discovery Protocol) provides a standards-based method for enabling switches to advertise themselves



5.9. BACnet Introduction & Products

• Introduction

BACnet, a data communication protocol for building automation and control networks, is developed under the auspices of the American Society of Heating, Refrigerating and Air-Conditioning Engineers (ASHRAE). It is an American national standard, an European standard, a national standard in more than 30 countries, and an ISO global standard. This protocol is comprehensive applied in vastly different applications such as heating, ventilating, and air-conditioning control, lighting control, access control, and fire detection systems. The BACnet protocol also provides mechanisms for computerized building automation devices to exchange information, regardless of the particular building service they perform.



BACnet Features

- Designed specifically for building automation control
- Conformance to ANSI/ASHRAE standard 135-2008 or ISO 16484-5
- A completely non-proprietary open communication software standard
- Support several different physical and link layers (BACnet/IP, Ethernet, ARCNET, MS/TP, PTP and LonTalk)
- All data in a BACnet system is represented in terms of "objects", "properties" and "services"
- Scalability and choice of compatibility with other systems and vendors

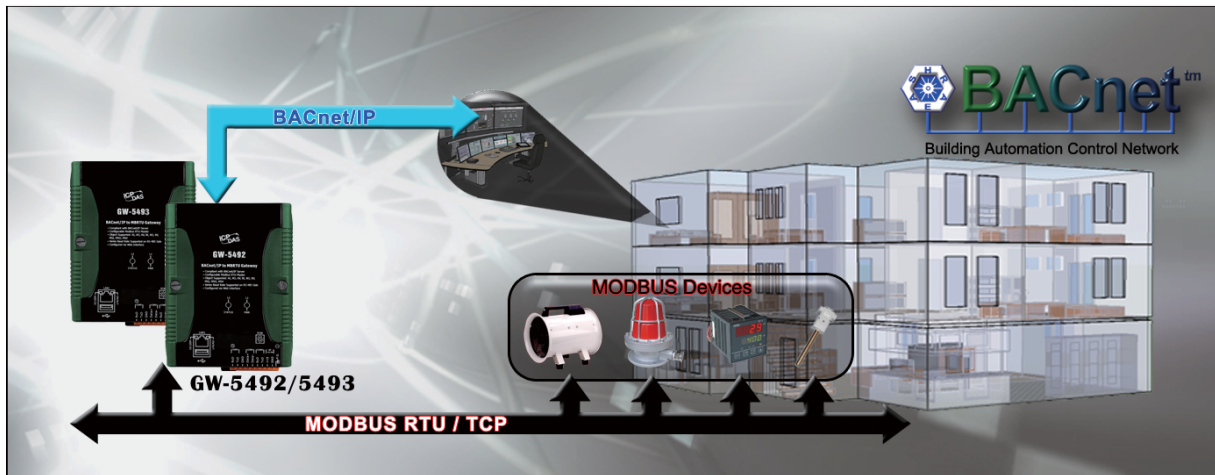

• Application Stories

▶▶▶ Commercial Building Automation System

Product: GW-5492

The customer used the SCADA, InduSoft Web Studio, with BACnet/IP driver to integrate with BACnet/IP devices and controllers in a commercial building including 210 air volume terminals, 22 air handling units, 3 chillers...etc. Using GW-5492, the customer was able to integrate those Modbus RTU devices to BACnet/IP network. By doing these is to eliminate multiple protocols on the network and easy maintenance in the future. The system monitors and controls nearly 2500 physical inputs and outputs which are connected to the InduSoft residing on the BACnet/IP networks. InduSoft also configured a powerful feature that showed facility personnel peak demand trends on energy usage and sequence unit operations to minimize energy consumption. The building retains 10% energy savings each month after new system installed.

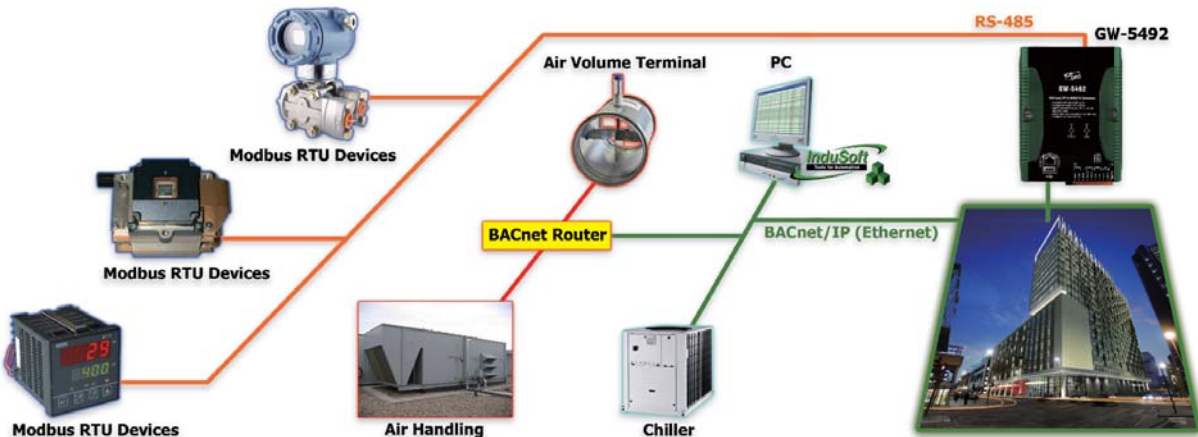

▶▶▶ Building Automation of a Medical Center

Product: GW-5493

The customer form a medical center used the SCADA, InduSoft Web Studio, to integrate numerous third party devices using BACnet/IP protocol – including the hospital emergency power transfer switches, water booster pumps, and HVAC system. For those existing Modbus TCP devices, the customer added the GW-5493 BACnet/IP to Modbus gateway in order to make the devices accessible using BACnet/IP protocol. The system integration provides the information necessary to make complex decisions driving energy savings and properly monitor the equipment. With GTM-201, the system allows the operator to receive alarms and monitoring points via SMS messages. The building automation system also trends data regularly so that the client can use the information to track costs and troubleshoot equipment from historical data.

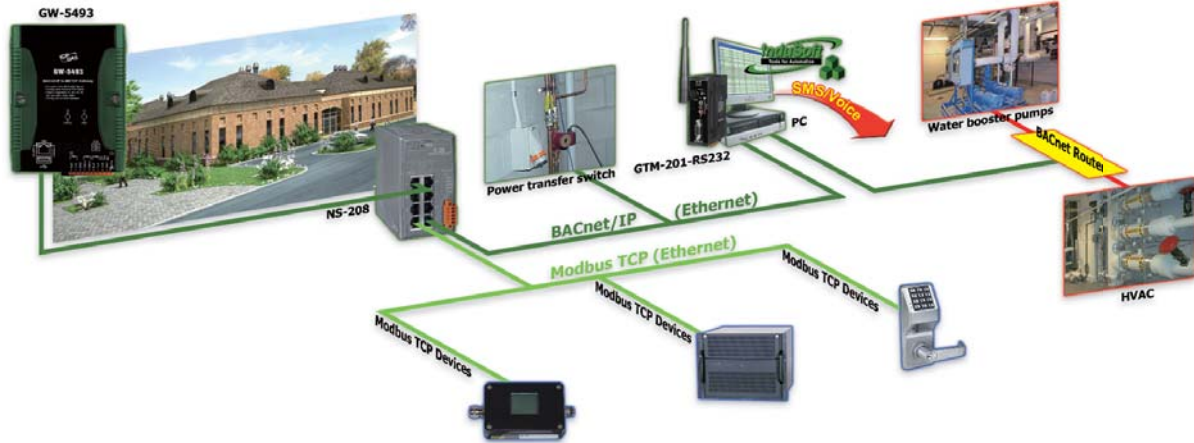

● Selection Guide

Model Name	BACnet Ports	Interface	Description	Page
BACnet Gateways				
GW-5492	1	BACnet/IP server ↔ RS-232/RS-485	BACnet/IP Server to Modbus RTU master gateway	5-9-2
GW-5493	1	BACnet/IP server ↔ Ethernet	BACnet/IP Server to Modbus TCP client gateway	

● Product Showcase

BACnet Gateways

▶▶▶ BACnet/IP Server to Modbus RTU Master Gateway

GW-5492 CR **NEW**

The GW-5492 is a fully configurable universal Modbus RTU to BACnet/IP gateway. The GW-5492 includes the functions of the BACnet/IP server and Modbus RTU master, and is suited for making the Modbus RTU devices accessible on a BACnet/IP network. Besides, the GW-5492 can be configured via the web interface.

- Quickly and cost effectively integrate networks
- Read/Write any standard Modbus registers via BACnet
- BIBB (BACnet Interoperability Building Blocks) supported: DS-RP-B, DS-RPM-B, DS-WP-B, DS-WPM-B, DS-COV-B, DM-DDB-B, DM-DOB-B, DM-DCC-B, DM-TS-B, DM-UTC-B, DM-RD-B
- Baud rates supported: 2400, 4800, 9600, 19200, 38400, 57600 and 115200 bps
- Provide PWR/Communication Status indication LED
- Fully compliant with BACnet/IP Server and Modbus RTU master
- BACnet object supported: AI, AO, AV, BI, BO, BV, MSI, MSO, MSV
- Supports Modbus coils, input register, holding registers
- No programming required
- Modbus register mapping table configured via web interface



▶▶▶ BACnet/IP Server to Modbus TCP Client Gateway

GW-5493 CR **NEW**

The GW-5493 is a BACnet/IP server to Modbus TCP gateway. Similar with the GW-5492, the GW-5493 provides a solution for the Modbus TCP devices connecting with the BACnet/IP network. Besides, the GW-5493 can be configured by the webpage. It is more convenient for setting the GW-5493 while applying it.

- Quickly and cost effectively integrate networks
- Read/Write any standard Modbus registers via BACnet
- BIBB (BACnet Interoperability Building Blocks) supported: DS-RP-B, DS-RPM-B, DS-WP-B, DS-WPM-B, DS-COV-B, DM-DDB-B, DM-DOB-B, DM-DCC-B, DM-TS-B, DM-UTC-B, DM-RD-B
- 10/100 Base-TX Ethernet Controller
- Modbus register mapping table configured via web interface
- Provide PWR/Communication Status indication LED
- Fully Compliant with BACnet/IP Server and Modbus TCP Client
- BACnet object supported: AI, AO, AV, BI, BO, BV, MSI, MSO, MSV
- Supports Modbus coils, input register, holding registers
- No programming required



Ethernet Switches



6-1 Overview	6-1-1
6-2 Product Showcase	6-2-1
• Unmanaged Ethernet Switches	6-2-1
• Managed Ethernet Switches	6-2-3
• Media Converters	6-2-4

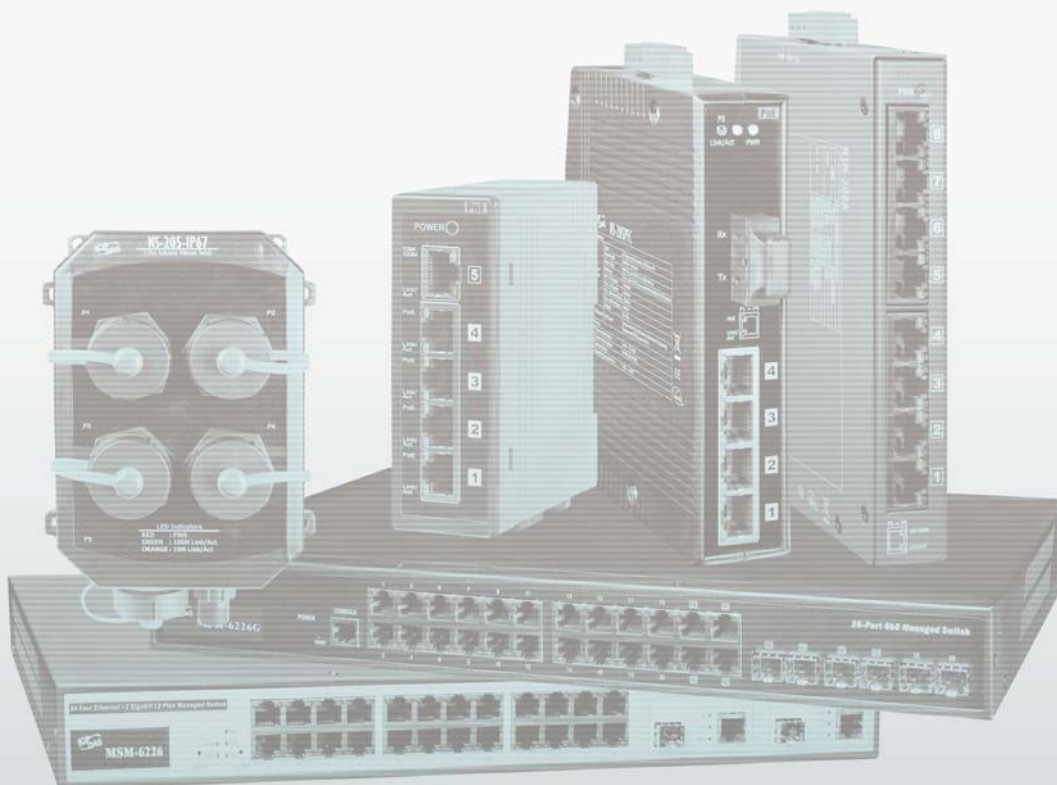

6-1 Overview

Ethernet is an ideal medium to transport large volumes of data, at speed, across great distances. Previously, multiple networks carrying specific protocols were installed side by side to carry out unique tasks. This inevitably led to project costs increasing as additional fiber optic or copper cables were installed to deal with the increasing volume of data. Using Ethernet a single fiber optic cable can carry multiple protocols. Furthermore, manufacturers are exporting their legacy protocols onto Ethernet, designing new IP based communication protocols and providing embedded Web-Pages within devices that offer real-time information using simple tools like Internet Explorer and Netscape Navigator.

Early Ethernet were based on a hub or repeater. These units have no intelligence and therefore are unable to identify any information contained within the Header frame of an Ethernet packet. This means that it is not capable of determining which port to send the frame to. Therefore, every frame is sent to every port.

A switch, like a hub, has to forward and receive packets from one network or device to another. The switch could forward all packets, but if this was the case it would have similar behaviour to a hub. It would be more intelligent if the switch only forwarded packets which needed to travel from one network or device to another.

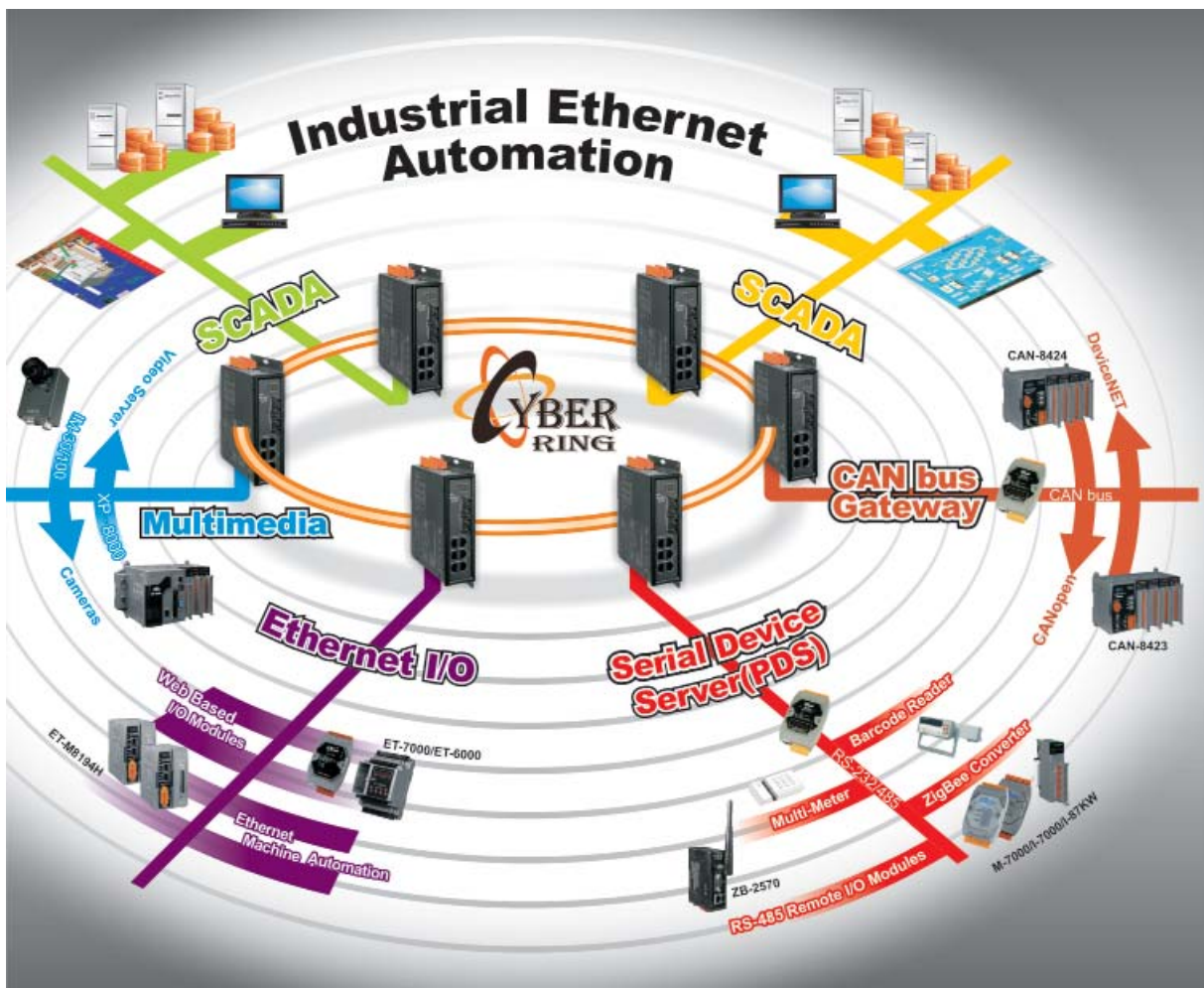

There are many poorly designed switches existing in the market, and most of them are fragile, easy to collapse, and always suffer from transmission delay and unreliable communication conditions due to packet collisions or other issues. Users who have bad experiences with those poor switches should try our high quality ones. ICP DAS's switches only choose "REAL INDUSTRIAL" grade switch chips that are temperature tolerant and highly reliable. They are all well-designed by skilled engineers and passed very strict communication and environment tests. All our switches can serve for a long life and guarantee to function perfectly under harsh environment.

▶▶▶ Managed Switch for Industrial Ethernet Application

The managed switch can be configured through RS-232 port via serial console or Ethernet port using telnet or Web browser. In addition, the switch supports a lot of powerful managed functions, such as 802.1Q Tag-based VLAN, Port-based VLAN, 802.1p QoS (Quality of Service), Port Trunking, Spanning Tree, Cable Testing and Port Mirroring.

Built-in ICP DAS Cyber-Ring technique enables multiple switches to be placed into a redundant ring. Typically the switch detects and recovers from a fiber or copper link failure within approximately 20 ms – for the majority of applications a seamless process. Modbus/TCP, Modbus/RTU and OPC supported, SCADA application can monitor status of Ethernet and fiber port with Modbus or OPC protocol.



►►►► Real-time Redundant Ring Switch

The Real-time Redundant Ring Switch offers fault-tolerant industrial Ethernet with ring network topology. The built-in ICP DAS proprietary Cyber-Ring technology detects and recovers from a fiber or copper link failure within approximately 20 ms – for the majority of applications a seamless process. Modbus/TCP, Modbus/RTU and OPC supported, SCADA application can monitor status of Ethernet and fiber port with Modbus or OPC protocol. And, the relay output facility can deliver warning signal while dual power or network link fails.

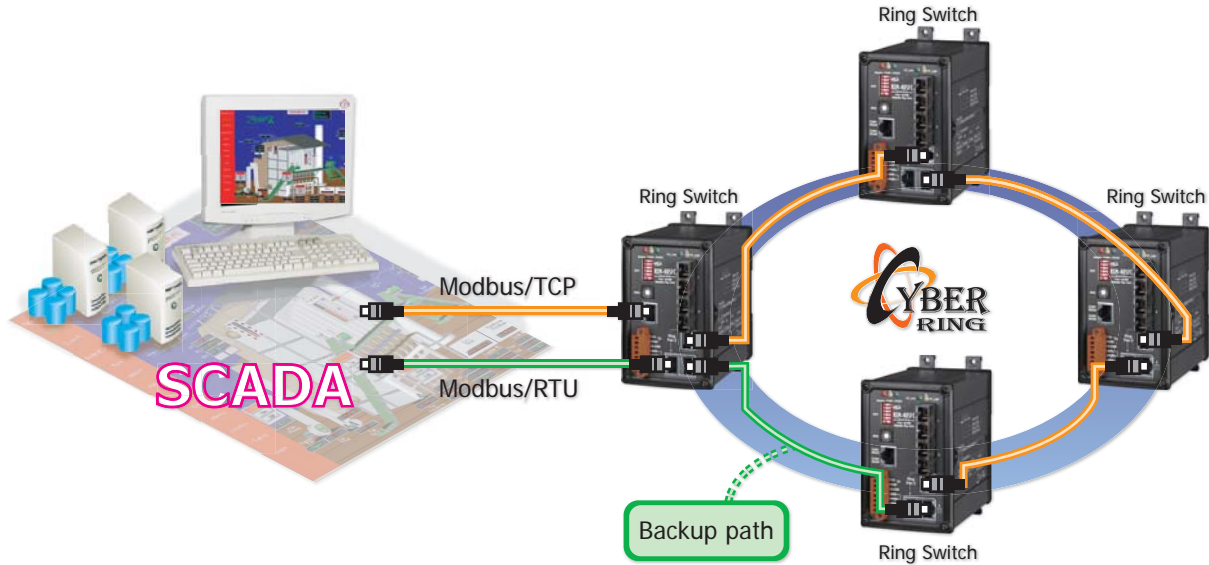

►►►► Managed Ethernet Switch

The ICP DAS Managed Switch provides a cost-effective managed Ethernet solution for industrial control and automation. It provides lots of powerful managed functions, such as 802.1Q Tag-based VLAN, Port-based VLAN, 802.1p QoS (Quality of Service), Port Trunking, Spanning Tree, Cable Testing and Port Mirroring. These managed functions can be configured through RS-232 port via serial console or Ethernet port using telnet or Web browser. In addition, the built-in Cyber-Ring technology offers real-time fault-tolerant ring topology to increase the reliability and performance of network. It is an ideal Managed Switch for industrial environments.



▶▶▶ Cyber-Ring Ethernet Self-healing Technology

The power of applying an Ethernet LAN (Local Area Network) to factory floor or industrial automation applications is undoubtedly tremendous. However, a commercial Ethernet switch cannot meet the high reliability requirements demanded by industrial applications. To satisfy these requirements, ICP DAS's Cyber-Ring technology provides you a rugged fault-tolerant, plug and play Ethernet solution.

The ICP DAS's proprietary Cyber-Ring self-healing Ethernet technology can establish industrial Ethernet with high reliability and fault-tolerant capability. It can employ a ring topology network over either copper or fiber optic cable. While standard STP typically requires 20s to 30s for network structure reconfiguration following a link failure, Cyber-Ring technology reduces this downtime to within half a second. Average experience indicates a typical fault recovery time is 20 ms for Cyber-Ring fault-tolerant network.

Features

- High reliability and fault-tolerant
- Real-time deterministic performance
- Scalable and flexible ring topology
- Cost-effective industrial redundant Ethernet solution
- Plug and play

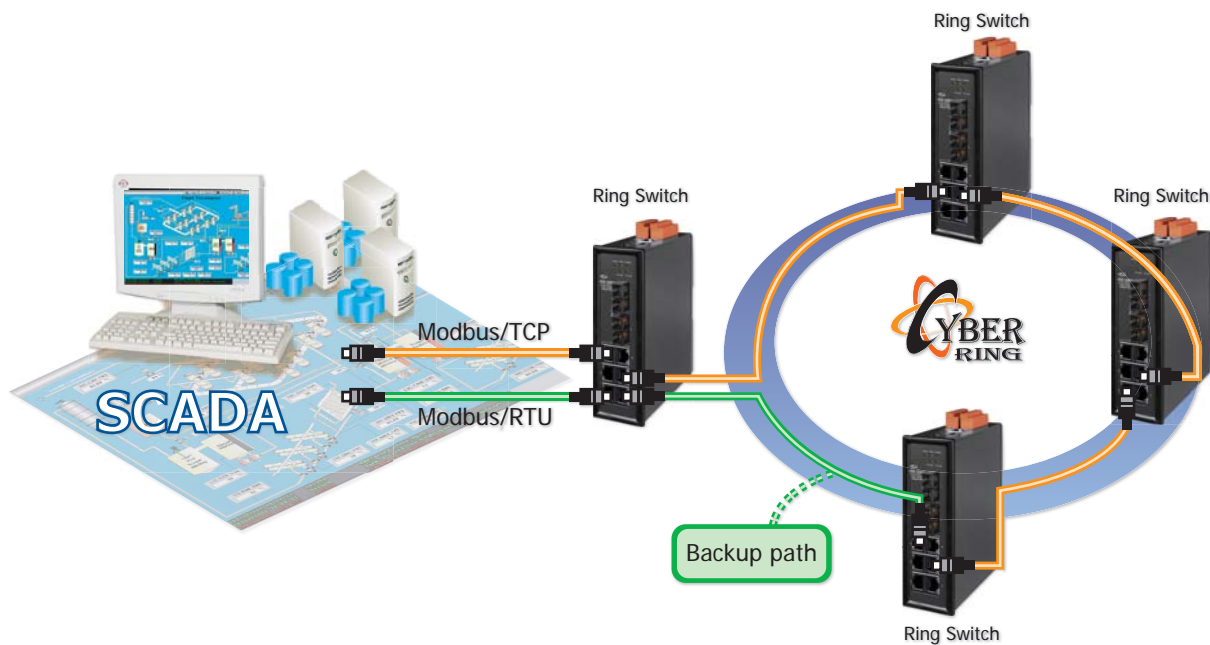

Recovery Time

The recovery time of Cyber-Ring network consists of two parts, fault detected time and reconfiguration time. Recovery time of Cyber-Ring network is associated with the number of switches of the network and Cyber-Ring technology offers a variable preconfigured recovery time to support a wide range of number of switches. Typically, the recovery time of Cyber-Ring network is less than 20 ms.

Fault Detected Time

Fault detected time is defined as the time from the occurrence of the fault until fault detected. There is a master switch of Cyber-Ring network checks the health condition of Cyber-Ring network periodically. If active path is not response after a preconfigured period of time, the master assumes that active path is failed and invokes reconfiguration mechanism to redirect traffics to the backup path.

Reconfiguration Time

The reconfiguration time of Cyber-Ring network is less than 5 ms per switch. For example, a Cyber-Ring fault-tolerant network that is comprised of ten switches, the expected worst case reconfiguration time will be 50 ms. When a fault is detected, the Cyber-Ring network will reconfigure to provide alternative traffic path of the ring within 50 ms.

►►►► **Unmanaged Ethernet Switch**

Industrial rated switches are intended to be installed in both harsh climatic environments and noisy electrical installations. Such switches are an excellent example of true industrial design principles

- Very high operating temperatures (down to -40 °C and up to +75 °C)
- DIN-Rail Mounting
- Wide DC operating voltages (+12 V_{DC} ~ +48 V_{DC})

NS-208G NS-208A NSM-208A



►►►► **PoE Ethernet Switch**

The PoE (Power over Ethernet) Ethernet Switch makes centralized power supply come true and provides up to 15.4 watts of power per port.

NS-205PSE NS-205PFT NSM-208PSE



►►►► **Rugged M12 Ethernet Switch**

The Rugged M12 Ethernet Switch is designed for industrial applications in harsh environments. The M12 connectors ensure tight, robust connections, and guarantee reliable operation, even for applications that are subject to high vibration and shock.

NSM-208-M12

NSM-208PSE-M12



►►►► **Media Converter**

The utilization of fiber optic data transmission for industrial automation and process control has become increasingly popular over the past decade. A basic fiber optic system, using an optical transceiver circuit and fiber optic media, offers a wide array of benefits that are not available with traditional copper conductors.

NS-200AFC-T

NS-200AFT-T



►►►► **IP67 Water Proof Switch**

IP67 Ethernet Switches are designed for use in industrial waterproof/harsh environments. The rugged packaging and IP67 connectors guarantee a total protection that can withstand a variety of extreme conditions such as high temperatures, extreme shocks & vibrations, dust particles or even liquid immersion. They can be directly mounted to any machine or convenient flat surface.

NS-205-IP67

NS-208-IP67

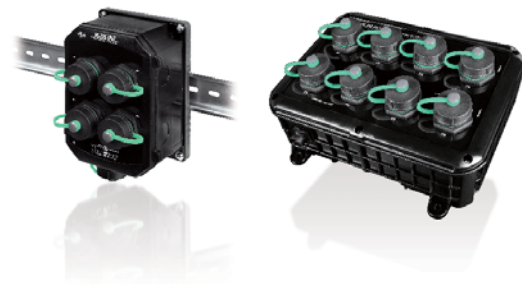

6.2. Product Showcase

✓ Unmanaged Ethernet Switches

▶▶▶▶ 5-port 10/100 Base-TX

NS-205 CR Series NS-205A CR Series

The NS-205 series has 5 Ethernet Switching ports that support 10/100 Base-TX, with a 10/100M auto negotiation feature and auto MDI/MDI-X function.

- Automatic MDI/MDI-X crossover for plug-and-play
- Store-and-forward architecture
- Power Input +12 Vdc ~ +56 Vdc for NS-205A
- Reverse Polarity Protection
- DIN-Rail Mounting
- Each port supports both 10/100 Mbps speed auto negotiation
- Full duplex IEEE 802.3x and half duplex backpressure flow control
- Store-and-forward architecture
- Operating temperature range: -40 °C ~ +75 °C

NS-205/NS-205A



▶▶▶▶ 8-port 10/100 Base-TX

NS-208A CR NSM-208A CR *NEW*

The NS-208A/NSM-208A series has 8 Ethernet Switching ports that support 10/100 Base-TX, with a 10/100M auto negotiation feature and auto MDI/MDI-X function.

- Automatic MDI/MDI-X crossover for plug-and-play
- Store-and-forward architecture
- 2 Gbps high performance memory bandwidth
- Operating temperature range: -40 °C ~ +75 °C
- DIN-Rail Mounting
- Each port supports both 10/100 Mbps speed auto negotiation
- Full duplex IEEE 802.3x and half duplex backpressure flow control
- Power Input +12 Vdc ~ +48 Vdc

NSM-208A NS-208A



▶▶▶▶ 5-port 10/100/1000 Base-T

NS-205G CR

The NS-205G is 5-port unmanaged gigabit switch that support 10/100/1000 Base-T, with a 10/100/1000M auto negotiation feature and auto MDI/MDI-X function. It can connect 5 workstations and automatically switch the transmission speed (10 Mbps or 100 Mbps or 1000 Mbps) for corresponding connections.

- Power saving Technology
- Each port supports 10/100 and 1000 Mbps speed auto negotiation
- 10 Gbps high performance memory bandwidth
- Power Input +10 Vdc ~ +30 Vdc
- DIN-Rail Mounting
- Automatic MDI/MDI-X crossover for plug-and-play
- Store-and-forward architecture
- Full duplex IEEE 802.3x and half duplex backpressure flow control
- Operating temperature range: -40 °C ~ +75 °C

NS-205G



▶▶▶▶ 8-port 10/100/100 Base-T

NS(M)-208G CR Series NS(M)-208AG CR Series

The NS-208G/NSM-208G series has 8 Ethernet Switching ports that support 10/100/1000 Base-T, with a 10/100/1000M auto negotiation feature and auto MDI/MDI-X function. It can connect 8 workstations and automatically switches the transmission speed (10 Mbps or 100 Mbps or 1000 Mbps) for corresponding connections.

- Automatic MDI/MDI-X crossover for plug-and-play
- Store-and-forward architecture
- 16 Gbps high performance memory bandwidth
- Power Input +10 Vdc ~ +30 Vdc for NS-208G and NSM-208G
- Power Input +12 Vdc ~ +48 Vdc for NS-208AG and NSM-208AG
- Each port supports 10/100 and 1000 Mbps speed auto negotiation
- Full duplex IEEE 802.3x and half duplex backpressure flow control
- Operating temperature range: -40 °C ~ +75 °C
- DIN-Rail Mounting

NSM-208G NS-208G



▶▶▶▶ 4-port 10/100 Base-TX and 100 Base-FX Fiber

NS-205AF CR Series NSM-205AF CR Series *NEW*

The NS-205AF/NSM-205AF series is a Unmanaged 4-port Industrial Ethernet (10/100 Base-TX) to Fiber Port (100 Base-FX) switch that secures data transmission by using fiber optic transmission to provide immunity from EMI/RFI interference.

- Automatic MDI/MDI-X crossover for plug-and-play
- Store-and-forward architecture
- 2 Gbps high performance memory bandwidth
- Operating temperature range: -30 °C ~ +75 °C
- Redundant Power Inputs +12 Vdc ~ +48 Vdc
- Each port supports both 10/100 Mbps speed auto negotiation
- Full duplex IEEE 802.3x and half duplex backpressure flow control
- Frame buffer memory: 512 Kbit

NS-205AFT-T NSM-205AFT-T



▶▶▶▶ 4-port 10/100 Base-TX and Dual 100 Base-FX Fiber

NS-206AF CR Series **NEW**
NSM-206AF CR Series

The NS-206AF/NSM-206AF series is a Unmanaged 4-port Industrial 10/100 Base-TX and Dual 100 Base-FX Switch that secures data transmission by using fiber optic transmission to provide immunity from EMI/RFI interference.

- Automatic MDI/MDI-X crossover for plug-and-play
- Store-and-forward architecture
- 2 Gbps high performance memory bandwidth
- Redundant Power Inputs +12 Vdc ~ +48 Vdc
- Operating temperature range: -30 °C ~ +75 °C
- Each port supports both 10/100 Mbps speed auto negotiation
- Full duplex IEEE 802.3x and half duplex backpressure flow control
- Frame buffer memory: 512 Kbit
- DIN-Rail Mounting

NS-206AFT-T NSM-206AFT-T



▶▶▶▶ 8-port 10/100 Base-TX and 100 Base-FX Fiber

NS-209F CR Series **NEW**
NSM-209F CR Series *Available soon*

The NS-209F/NSM-209F series is a Unmanaged 8-port Industrial 10/100 Base-TX and one 100 Base-FX Switch that secures data transmission by using fiber optic transmission to provide immunity from EMI/RFI interference.

- Automatic MDI/MDI-X crossover for plug-and-play
- Store-and-forward architecture
- 2 Gbps high performance memory bandwidth
- Redundant Power Inputs +12 ~ +48 Vdc for NSM-209F series
- Operating temperature range: 0 °C ~ +70 °C
- Each port supports both 10/100 Mbps speed auto negotiation
- Full duplex IEEE 802.3x and half duplex backpressure flow control
- DIN-Rail Mounting

NSM-209FT NS-209FC



▶▶▶▶ 5-port 10/100 Base-TX with IP67 Casing

NS-205-IP67 CR Series

NS-205-IP67 Ethernet switch is designed for use in industrial waterproof/harsh environments.

- Automatic MDI/MDI-X crossover for plug-and-play
- Store-and-forward architecture
- 1.4 Gbps high performance memory bandwidth
- Power Input +10 Vdc ~ +30 Vdc (with 1 kV isolation Reverse Polarity Protection)
- Plastic casing with IP67
- Each port supports both 10/100 Mbps speed auto negotiation
- Full duplex IEEE 802.3x and half duplex backpressure flow control
- Operating temperature range: -10 °C ~ +60 °C
- DIN-Rail Mounting

NS-205-IP67



▶▶▶▶ 4-port PoE and 1 RJ-45 Uplink

NS-205PSE CR Series **NEW**
NS-205PSE-24V CR Series

The NS-205PSE is a 5-port unmanaged PoE (Power over Ethernet) Industrial Ethernet Switch, it supports 4-PoE Port which are classified as power source equipments (PSE).

- Automatic MDI/MDI-X crossover for plug-and-play
- Each port supports both 10/100 Mbps speed auto negotiation
- Full duplex IEEE 802.3x and half duplex backpressure flow control
- 3.2 Gbps high performance memory bandwidth
- Power Input +46 Vdc ~ +55 Vdc for NS-205PSE
- Power Input +18 Vdc ~ +32 Vdc for NS/NSM-205PSE-24V
- DIN-Rail Mounting
- Store-and-forward architecture
- Operating temperature range: -40 °C ~ +75 °C
- IEEE 802.3af compliant PoE ports
- 4-PoE Port with power sourcing equipment (PSE) operation Auto-detection of PD (powered devices) and automatic power management over-temperature, over-current and over/under-voltage detection

NSM-205PSE-24V NS-205PSE



▶▶▶▶ 4-port PoE and 100 Base-FX Fiber

NS-205PF CR Series **NEW**
NSM-205PF CR Series

The NS-205PF is a 5-port unmanaged PoE (Power over Ethernet) Industrial Ethernet Switch, it supports 4-PoE Port which are classified as power source equipments (PSE).

- Automatic MDI/MDI-X crossover for plug-and-play
- Each port supports both 10/100 Mbps speed auto negotiation
- Store-and-forward architecture
- Full duplex IEEE 802.3x and half duplex backpressure flow control
- 3.2 Gbps high performance memory bandwidth
- Power Input +46 Vdc ~ +55 Vdc
- Operating temperature range: -30 °C ~ +75 °C
- DIN-Rail Mounting
- IEEE 802.3af compliant PoE ports
- 4-PoE Port with power sourcing equipment (PSE) operation Auto-detection of PD (powered devices) and automatic power management over-temperature, over-current and over/under-voltage detection

NSM-205PFT-T NS-205PFC-T



▶▶▶▶ 8-port Industrial 10/100 Mbps Ethernet with 4-PoE (PSE) Switch

NS-208PSE-4 CR **NEW**
NSM-208PSE-4 CR

The NS(M)-208PSE-4 is a 8-port unmanaged PoE (Power over Ethernet) Industrial Ethernet Switch, it supports 4-PoE Port which are classified as power source equipments (PSE).

- Automatic MDI/MDI-X crossover for plug-and-play
- Each port supports both 10/100 Mbps speed auto negotiation
- Store-and-forward architecture
- Full duplex IEEE 802.3x and half duplex backpressure flow control
- 3.2 Gbps high performance memory bandwidth
- Power Input +46 Vdc ~ +55 Vdc
- Operating temperature range: -40 °C ~ +75 °C
- DIN-Rail Mounting
- IEEE 802.3af compliant PoE ports
- 4-PoE Port with power sourcing equipment (PSE) operation Auto-detection of PD (powered devices) and automatic power management over-temperature, over-current and over/under-voltage detection

NSM-208PSE-4 NS-208PSE-4



▶▶▶▶ 8-port Industrial 10/100 Mbps Ethernet with 8-PoE (PSE) Switch

NS-208PSE CR
NSM-208PSE CR

The NS(M)-208PSE is a 8-port unmanaged PoE (Power over Ethernet) Industrial Ethernet Switch, it supports 8-PoE Port which are classified as power source equipments (PSE).

- Automatic MDI/MDI-X crossover for plug-and-play
- Each port supports both 10/100 Mbps speed auto negotiation
- Store-and-forward architecture
- Full duplex IEEE 802.3x and half duplex backpressure flow control
- 3.2 Gbps high performance memory bandwidth
- Power Input +46 Vdc ~ +55 Vdc
- Operating temperature range: -40 °C ~ +75 °C
- DIN-Rail Mounting
- IEEE 802.3af compliant PoE ports
- 8-PoE Port with power sourcing equipment (PSE) operation
- Auto-detection of PD (powered devices) and automatic power management over-temperature, over-current and over/under-voltage detection

NSM-208PSE NS-208PSE



✓ Managed Ethernet Switches

▶▶▶▶ 5-port Real-time Redundant Ring Switch

RS-405 CR Series
RSM-405 CR Series

The RS-405/RSM-405 series is a 5-port Industrial Ethernet (10/100 Base-TX) Real-time Redundant Ring Switch.

- Automatic MDI/MDI-X crossover for plug-and-play
- Store-and-forward architecture
- 3.2 Gbps high performance memory bandwidth
- Frame buffer memory: 1 Mbit
- Supports 2K MAC Addresses
- Operating temperature range: -40 °C ~ +75 °C
- Each port supports both 10/100 Mbps speed auto negotiation
- Full duplex IEEE 802.3x and half duplex backpressure flow control
- Redundant Power Inputs +10 Vdc ~ +30 Vdc
- Power failure alarm by relay output
- DIN-Rail Mounting

RSM-405 RS-405



▶▶▶▶ 5-port Real-time Redundant Ring Switch with 2-Fiber Port

RS-405F CR Series
RSM-405F CR Series

The RS-405F/RSM-405F series is a 5-port Industrial Ethernet Real-time Redundant Ring Switch with 2-Fiber Port that secures data transmission by using fiber optic transmission to provide immunity from EMI/RFI interference.

- Automatic MDI/MDI-X crossover for plug-and-play
- Store-and-forward architecture
- 3.2 Gbps high performance memory bandwidth
- Frame buffer memory: 512 Kbit
- Supports 2K MAC Addresses
- Operating temperature range: 0 °C ~ +70 °C
- Each port supports both 10/100 Mbps speed auto negotiation
- Full duplex IEEE 802.3x and half duplex backpressure flow control
- Redundant Power Inputs +10 Vdc ~ +30 Vdc
- Power failure alarm by relay output
- DIN-Rail Mounting

RSM-405FT RS-405FC



▶▶▶▶ 8-port Real-time Redundant Ring Switch

RS-408 CR Series
RSM-408 CR Series

The RS-408/RSM-408 series is an 8-port Industrial Ethernet (10/100 Base-TX) Real-time Redundant Ring Switch.

- Automatic MDI/MDI-X crossover for plug-and-play
- Store-and-forward architecture
- 3.2 Gbps high performance memory bandwidth
- Frame buffer memory: 1 Mbit
- Supports 2K MAC Addresses
- Operating temperature range: -40 °C ~ +75 °C
- Each port supports both 10/100 Mbps speed auto negotiation
- Full duplex IEEE 802.3x and half duplex backpressure flow control
- Redundant Power Inputs +10 Vdc ~ +30 Vdc
- Power failure alarm by relay output
- DIN-Rail Mounting

RSM-408 RS-408



▶▶▶▶ 8-port Industrial Ethernet Layer 2 Managed Switch

MSM-508 CR

The MSM-508 is an 8-port Industrial Ethernet (10/100 Base-TX) Layer 2 Managed Switch. MSM-508 supports 10/100M auto negotiation feature and auto MDI/MDI-X function.

- Automatic MDI/MDI-X crossover for plug-and-play
- Store-and-forward architecture
- 3.2 Gbps high performance memory bandwidth
- Frame buffer memory: 1 Mbit
- Supports 2K MAC Addresses
- Operating temperature range: -40 °C ~ +75 °C
- Each port supports both 10/100 Mbps speed auto negotiation
- Full duplex IEEE 802.3x and half duplex backpressure flow control
- Redundant Power Inputs +12 Vdc ~ +48 Vdc
- Power failure alarm by relay output
- DIN-Rail Mounting and Screw hole for wall mounting kit

MSM-508



▶▶▶▶ 8-port Industrial Ethernet Layer 2 Managed Switch with 2-Fiber Port

MSM-508F CR Series

The MSM-508F series is an 8-port Industrial Ethernet Layer 2 Managed Switch with 2-Fiber Port that secures data transmission by using fiber optic transmission to provide immunity from EMI/RFI interference.

- Automatic MDI/MDI-X crossover for plug-and-play
- Store-and-forward architecture
- 3.2 Gbps high performance memory bandwidth
- Frame buffer memory: 1 Mbit
- Supports 2K MAC Addresses
- Operating temperature range: -30 °C ~ +75 °C
- Each port supports both 10/100 Mbps speed auto negotiation
- Full duplex IEEE 802.3x and half duplex backpressure flow control
- Redundant Power Inputs +12 Vdc ~ +48 Vdc
- Power failure alarm by relay output
- DIN-Rail Mounting and Screw hole for wall mounting kit

MSM-508FT-T MSM-508FC-T



▶▶▶▶ 24-port Ethernet + 2 TP/SFP Gigabit Dual Media Layer 2 Managed Switch

MSM-6226 *NEW*

The MSM-6226 is a 24-port Ethernet + 2 TP/SFP Gigabit Dual Media Layer2 Managed Switch. It's a standard switch that meets all IEEE 802.3/u/x/z Gigabit, Fast Ethernet and Ethernet specifications.

- 24 ports 10/100 Base-TX auto negotiation speed, F/H duplex mode, and auto MDI/MDI-X connection and 2 Gigabit Ethernet ports with non-blocking wise speed performance
- 8.8 Gbps high performance memory bandwidth
- Installing Chassis to a 19-Inch Wiring Closet Rail; No Wall mounting
- Frame Buffer Memory: Embedded 256 KB packet buffers and 128 KB control memory
- 2 Dual Media for Flexible Fiber Connection
- Operating temperature range: -10 °C ~ +60 °C
- Power Input 100 Vac ~ 240 Vac

MSM-6226



▶▶▶▶ 20-port Ethernet + 4 TP/SFP Dual Media + 2 SFP Layer 2 Gigabit Managed Switch

MSM-6226G *NEW*

The MSM-6226G provides security, performance, quality of services, central management and other network control capabilities. Optimized and customized design and affordable pricing, it best fit for SMB or entry-level enterprise solution.

- 20 ports 10/100/1000 Base-TX auto negotiation speed, F/H duplex mode, and auto MDI/MDI-X connection and 4 ports TP (100/1000) SFP Combo + 2 ports 100/1G SFP
- 52 Gbps high performance memory bandwidth
- Installing Chassis to a 19-Inch Wiring Closet Rail; No Wall mounting
- Operating temperature range: 0 °C ~ +40 °C
- Power Input 100 Vac ~ 240 Vac

MSM-6226G



Media Converters

▶▶▶▶ 10/100 Base-TX to 100 Base-FX

NS-200AF CR Series

The NS-200AF series is a Ethernet (10/100 Base-TX) to Media (100 Base-FX) converter. The Ethernet supports 10/100M auto negotiation feature and auto MDI/MDI-X function.

- Automatic MDI/MDI-X crossover for plug-and-play
- Store-and-forward architecture
- 1.4 Gbps high performance memory bandwidth
- Operating temperature range: -30 °C ~ +75 °C
- Reverse Polarity Protection
- Supports both 10/100 Mbps speed auto negotiation
- Full duplex IEEE 802.3x flow control
- Frame buffer memory: 256 Kbit
- Power Input +12 Vdc ~ +48 Vdc
- DIN-Rail Mounting

NS-200AFT-T NS-200AFC-T



▶▶▶▶ 1000 Base-T to 1000 Base-SX/LX

NS-200SX/NS-200LX *Available soon*

NS-200SX/LX is an enhanced gigabit Ethernet to fiber optic converter. Aside from its standard features, the versatile NS-200SX/LX also has the LFP (Link Fault Pass-through) feature. When one side of the link fails, the other side continues transmitting packets, and waiting for a response that never arrives from the disconnected side. NS-200SX/LX will force the link to shut down as soon as noticed that the other link has failed, giving the application software a chance to react to the situation.

- Provides 1 x 1000 Mbps fiber port with SC type connector for 1000 Base-SX/LX device
- Supports Jumbo Frames 9K bytes
- Provides Link Fault Pass-through (LFP)
- Supports redundant +12 Vdc ~ +48 Vdc power input
- Supports wide operating temperatures from -30 °C ~ +75 °C (NS-200SX-T/NS-200LX-T)

NS-200SX NS-200LX



▶▶▶▶ Single-Strand 10/100 Base-TX to 100 Base-FX

NS-200WDM CR Series

Using the fiber optic medium for Ethernet applications has become more popular due to fiber optic's excellent physical features, especially for long distance networks.

- Automatic MDI/MDI-X crossover for plug-and-play
- Store-and-forward architecture
- 1.4 Gbps high performance memory bandwidth
- Operating temperature range: 0 °C ~ +70 °C
- Reverse Polarity Protection
- Supports both 10/100 Mbps speed auto negotiation
- Full duplex IEEE 802.3x and half duplex backpressure flow control
- Power Input +12 Vdc ~ +48 Vdc
- DIN-Rail Mounting

NS-200WDM-A NS-200WDM-B



Accessories



7-1	Cables	-----	7-1-1
7-2	Power Supplies	-----	7-2-1
7-3	Terminal Boards & Connector	-----	7-3-1
7-4	USB Hub	-----	7-4-1



7.1. Cables

▶▶▶▶ CA-0903

Pin Assignments

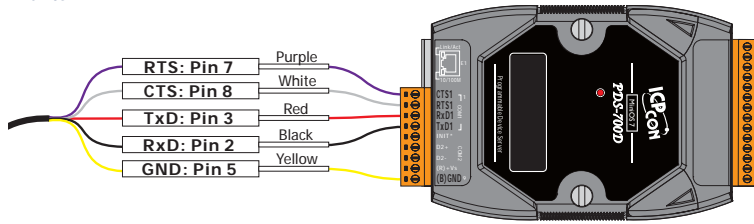

Ordering Information

CA-0903 9-Pin Female D-Sub and RS-232 Connector Cable, 30 cm

▶▶▶▶ CA-090910

Pin Assignments

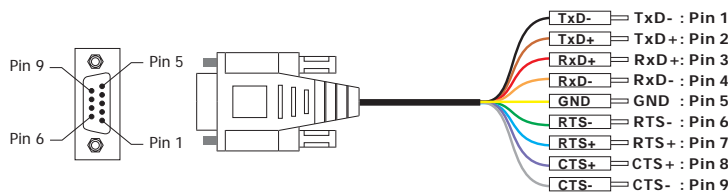

Ordering Information

CA-090910 9-Pin Female D-Sub Cable for RS-422 Connector, 1 m

▶▶▶▶ CA-0910

Pin Assignments

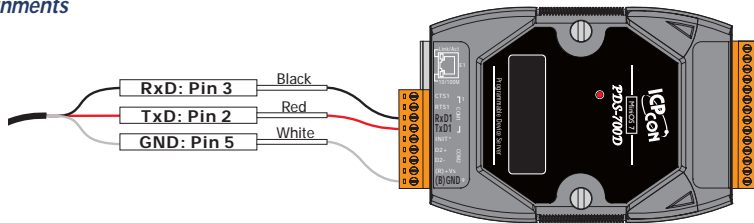

Ordering Information

CA-0910 9-Pin Female D-Sub and 3-wire RS-232 Cable, 1 m

▶▶▶▶ CA-0910F CA-0915

Pin Assignments

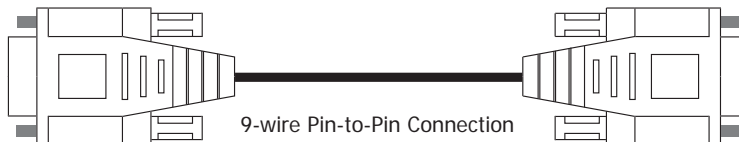

CA-0910F



CA-0915

Ordering Information

CA-0910F 9-Pin Female-Female D-Sub Cable, 1 m

CA-0915 9-Pin Male-Female D-Sub Cable, 1.5 m

▶▶▶▶ CA-9-2505D

Pin Assignments

Pin Assignment	Terminal No.	Pin Assignment
N/A	01	14 COM8_RxD
N/A	02	15 COM8_TxD
COM8_GND	03	16 COM7_RxD
N/A	04	17 COM7_TxD
COM7_GND	05	18 COM6_RxD
N/A	06	19 COM6_TxD
COM6_GND	07	20 COM5_RxD
N/A	08	21 COM5_TxD
COM5_GND	09	22 COM4_RxD
N/A	10	23 COM4_TxD
COM4_GND	11	24 COM3_RxD
N/A	12	25 COM3_TxD
COM3_GND	13	Shield F.G.

25-Pin Male D-Sub Connector

Pin Assignment	Terminal No.	Pin Assignment
GND	05	09 --
--	04	08 --
TxD	03	07 --
RxD	02	06 --
--	01	

RS-232 Female DB-25 to Male DB-9 Connector



Ordering Information

CA-9-2505D	Male DB-25 to 6 Male DB-9 Cable, 0.5 m
------------	--

▶▶▶▶ CA-9-3705
CA-9-3715D

Pin Assignments

Pin Assignment	Terminal No.	Pin Assignment
N.C.	01	20 RI3
DCD3	02	21 DTR3
GND	03	22 DSR3
CTS3	04	23 RTS3
RxD3	05	24 TxD3
RI4	06	25 DCD4
DTR4	07	26 GND
DSR4	08	27 CTS4
RTS4	09	28 RxD4
TxD4	10	29 RI2
DCD2	11	30 DTR2
GND	12	31 DSR2
CTS2	13	32 RTS2
RxD2	14	33 TxD2
RI1	15	34 DCD1
DTR1	16	35 GND
DSR1	17	36 CTS1
RTS1	18	37 RxD1
TxD1	19	

RS-232 Female DB-37 Connector

Pin Assignment	Terminal No.	Pin Assignment
GND	05	09 RI
DTR	04	08 CTS
TxD	03	07 RTS
RxD	02	06 DSR
DCD	01	

RS-232 Female DB-37 to Male DB-9 Connector



CA-9-3705



CA-9-3715D

Ordering Information

CA-9-3705	Male DB-37 to 4 Male DB-9 Cable (90°), 0.3 m
CA-9-3715D	Male DB-37 to 4 Male DB-9 Cable (180°), 1.5 m

▶▶▶▶ CA-USB18

Pin Assignments

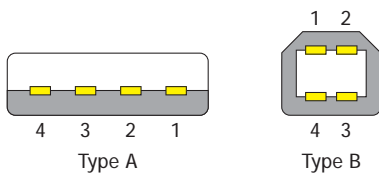

Pin	Name	Description
1	VCC	+5V
2	D-	Data-
3	D+	Data+
4	GND	Ground



Ordering Information

CA-USB18	USB Type A to Type B Cable, 1.8 m
----------	-----------------------------------

7.2. Power Supplies

▶▶▶ GPSU06U-6 **NEW**
GPSU06E-6 **NEW**



Specifications

Input	
Range	100 ~ 240 Vac or 127 ~ 370 Vdc
Frequency	50 Hz ~ 60 Hz
Output	
Power	24 Vdc/0.25 A max., 6 W
Mechanical	
Dimensions (W x H x D)	32 mm x 66 mm x 68 mm
Installation	No-mounting
Environmental	
Operating Temperature	0 °C ~ +40 °C
Storage Temperature	-20 °C ~ +85 °C



GPSU06U-6



GPSU06E-6

Ordering Information

GPSU06U-6	24 Vdc/0.25 A, 6W Power Supply
GPSU06E-6	24 Vdc/0.25 A, 6W Power Supply with 2 pole EURO plug

▶▶▶ MDR-20-24 **NEW**
MDR-60-24 **NEW**
MDR-60-48 **NEW**



Specifications

Models	MDR-20-24	MDR-60-24	MDR-60-48
Input			
Range	100 ~ 250 AC		
Frequency	50 Hz ~ 60 Hz		
Output			
Power	24 Vdc/1 A max., 24 W	24 Vdc/2.5 A max., 60 W	48 Vdc/1.25 A max., 60 W
Mechanical			
Dimensions (W x H x D)	22.5 x 90 x 100	40 x 90 x 100	40 x 90 x 100
Installation	DIN-Rail Mounting		
Environmental			
Operating Temperature	-20 °C ~ +70 °C		
Storage Temperature	-20 °C ~ +85 °C		



MDR-60-24/ MDR-20-24
MDR-60-48

Ordering Information

MDR-20-24	24 Vdc/1 A, 24 W Power Supply with DIN-Rail Mounting
MDR-60-24	24 Vdc/2.5 A, 60 W Power Supply with DIN-Rail Mounting
MDR-60-48	48 Vdc/1.25 A, 60 W Power Supply with DIN-Rail Mounting

▶▶▶ KA-52F/DIN-KA52F
KA52F-48/DIN-KA52F-48 **NEW**



Specifications

Models	KA-52F	DIN-KA52F	KA-52F-48	DIN-KA52F-48
Input				
Range	100 ~ 250 AC			
Frequency	50 Hz ~ 60 Hz			
Output				
Power	24 Vdc/1.04 A max., 25 W		48 Vdc/0.52 A max., 25 W	
Mechanical				
Dimensions (W x H x D, Unit: mm)	54 x 93 x 36	68 x 107 x 50	54 x 93 x 36	68 x 107 x 50
Installation	No-mounting	DIN-Rail Mounting	No-mounting	DIN-Rail Mounting
Environmental				
Operating Temperature	0 °C ~ +50 °C			
Storage Temperature	-20 °C ~ +85 °C			



KA-52F/KA-52F-48



DIN-KA52F/
DIN-KA52F-48

Ordering Information

KA-52F	24 Vdc/1.04 A, 25 W Power Supply
DIN-KA52F	24 Vdc/1.04 A, 25 W Power Supply with DIN-Rail Mounting
KA-52F-48	48 Vdc/0.52 A, 25 W Power Supply
DIN-KA52F-48	48 Vdc/0.52 A, 25 W Power Supply with DIN-Rail Mounting

▶▶▶▶ **DR-120-24** *NEW*
DR-120-48 *NEW*



Specifications

Models	DR-120-24	DR-120-48
Input		
Range	88 ~ 264 AC	
Frequency	47 Hz ~ 63 Hz	
Output		
Power	24 Vdc/5.0 A max., 120 W	48 Vdc/2.5 A max., 120 W
Mechanical		
Dimensions (W x H x D)	65 mm x 125 mm x 100 mm	
Installation	DIN-Rail Mounting	
Environmental		
Operating Temperature	-10 °C ~ +60 °C	
Storage Temperature	-20 °C ~ +85 °C	-25 °C ~ +85 °C



Ordering Information

DR-120-24	24 Vdc/5.0 A, 120W Power Supply with DIN-Rail Mounting
DR-120-48	48 Vdc/2.5 A, 120W Power Supply with DIN-Rail Mounting

7.3. Terminal Boards & Connector

▶▶▶▶ **DN-09-2**
DN-09-2F



Dimensions (Unit: mm)

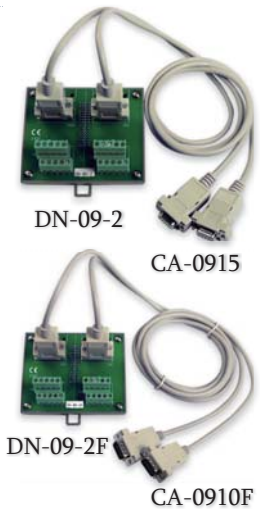
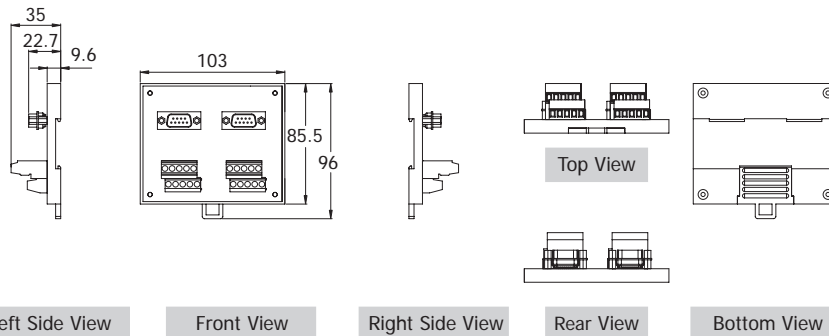

Ordering Information

DN-09-2	I/O Connector Block with DIN-Rail Mounting and Two 9-Pin Male Header Includes: CA-0915 x 2 (9-Pin Male-Female D-Sub Cable 1.5 M)
DN-09-2F	I/O Connector Block with DIN-Rail Mounting and Two 9-Pin Male Header Includes: CA-0910F x 2 (9-Pin Female-Female D-Sub Cable 1.0 M)

▶▶▶▶ **CA-4002**



Ordering Information

CA-4002	37-Pin Male D-Sub Connector with Plastic Cover
---------	--



▶▶▶▶ **CA-PC09F**



Ordering Information

CA-PC09F	Female D-Sub Connector with Plastic Cover
----------	---



7.4. USB Hub

▶▶▶ USB-2560 *NEW*



Features

- Compliant with USB Specification Revision 2.0
- Provides 4 Downstream Ports
- Only Supports Self-powered Mode +10 ~ + 30 Vdc
Power Input (power adapter included for USB-2560/S)
- DIN-Rail Mounting
- Built-in NEC uPD720114 USB 2.0 Hub Controller
- Supports High-speed (480 Mbps) and Full-speed (12 Mbps)
- Supports Downstream Port Status with LED



Introduction

The USB-2560 allows you to add multiple high performance USB 2.0 peripheral devices to your computer (Or XP-8000 series). It supports the USB 2.0 high-speed mode that can achieve 480 Mbps data transmitting rate. The USB-2560 only supports self-powered mode (drawing power from an external power supply). Externally powered USB hubs are the only way to guarantee the broadest compatibility for USB devices.

Specifications

Interface	
Ports	Upstream x 1 (Type B), Downstream x 4 (Type A)
Compatibility	Universal serial bus; Specification Rev. 2.0/1.1/1.0
Transfer Speed	480 Mbit/s-high speed mode, 12 Mbit/s- full speed mode, 1.5 Mbit/s-low speed mode
Supply Current	500 mA max. per port
Include Cable	CA-USB18 (1.8 m Cable) x 1
Power Supply Included (USB-2560/S Only)	GPSU06U-6 x 1 for 250 mA per port
LED Indicators	
Power	1 LED
Downstream Ports	4 LEDs
Power	
Input Voltage Range	+10 ~ + 30 Vdc
Power Consumption	0.25 A @ 24 Vdc for 250 mA per port, 0.5 A @ 24 Vdc for 500 mA per port
Power Input Connection	Removable 3-Pin Terminal Block
Mechanical	
Casing	Plastic
Flammability	UL 94V-0 materials
Dimensions (W x L x H)	33 mm x 78 mm x 107 mm
Installation	DIN-Rail Mounting
Environment	
Operating Temperature	0 °C ~ +70 °C
Storage Temperature	-20 °C ~ +80 °C
Humidity	10 ~ 90% RH, non-condensing

Ordering Information

USB-2560 CR	4-port Industrial USB 2.0 Hub (RoHS)
USB-2560/S CR	4-port Industrial USB 2.0 Hub with GPSU06U-6 (Power Supply) (RoHS)

Accessories

DIN-KA52F	24 Vdc/1.04 A, 25 W Power Supply with DIN-Rail Mounting
MDR-20-24	24 Vdc/1 A, 24 W Power Supply with DIN-Rail Mounting
GPSU06E-6	24 Vdc/0.25 A, 6W Power Supply with 2 pole EURO plug

Wireless Networking Solutions



- 8-1 Overview -----8-1-1
- 8-2 WLAN Products -----8-2-1
- 8-3 DSSS RF Products -----8-3-1
- 8-4 2G/3G Products -----8-4-1
- 8-5 ZigBee Products -----8-5-1
- 8-6 GPS Products -----8-6-1
- 8-7 Infrared Products -----8-7-1
- 8-8 Wireless Applications -----8-8-1



8-1 Overview

Industrial Wireless Communication creates new prospects for automation. In the harsh environment, chemicals, vibrations, or moving parts could potentially damage cabling. Industrial Wireless Communication system substantially reduces cost and time for the installation and maintenance of the large number of cable, thus makes plants setup and reconfiguration easy and safe.

ICP DAS provides a great variety of wireless products with modular and universal solution specially designed for industrial harsh environment.

ICP DAS Wireless and Mobile Total Solution

APPLICATION

- SMART
- VxComm Utility
- NAPOPC
- Software/SCADA/Utility
- InduSoft
- EZ Data Logger
- Soft-GRAB
- Web HMI

CONTROL

- WP/LP-5000
- WP/LP-8000
- iPAC-8000
- ViewPAC-zXWx
- XPAC-8000
- IO Modules
- μPAC/PDS
- X-Board
- PCI/ISA Card

COMMUNICATION

DSSS RF	2G/3G	WLAN	ZigBee	GPS	PROFIBUS / CAN Bus
SST-2450	GTM-201 Series	Wi-Fi AP	ZigBee Converters	GPS Receivers	Converter / Gateway
RF-87Kn	G-4500 Series	I-7540D-WF	ZigBee I/O	Train	CAN-8000
CNC Machine	GT-500 Series	M2M-711D	ZigBee Repeater	Public Transportation	CAN Device
Meters	Truck	Barcode Reader	Remote Controller	Cruise	PROFIBUS Device
DSSS RF/2G/3G/WLAN/GPS/Zigbee					PROFI-8000

Device

8-2 WLAN Products

WLAN (Wireless Local Area Network) links devices by wireless distribution method (spread-spectrum or OFDM radio), and generally provides a connection through an access point to the internet. WLAN allows users to move device within a local coverage area, and still be connected to the network. High-bandwidth allocation for wireless will make a relatively low-cost wiring possible.

ICP DAS provides a great variety of WLAN products which are compliant with standard of IEEE 802.11. The WLAN products have two modes: Ad-hoc and Infrastructure.

Advantages & Benefits

- Build a wireless network via Wi-Fi technology. There is no need to build an expansive fixed line network.
- Enable CAN/Serial/Ethernet device to be connected to the same network via Wi-Fi without any cable.
- Use widely available IEEE 802.11 (Wi-Fi) or Ethernet network infrastructure.
- Support IEEE 802.11 b/g for Wi-Fi and Ad Hoc modes.
- Secure data access with WEP, WPA, WPA2.



● WLAN Selection Guide

WLAN Remote Maintenance Device

Model Name	Interface	WiFi standard	Data Encryption
M2M-711D	5-wire RS-232 x 1 2-wire RS-485 x 1 10/100M Ethernet x 1	IEEE 802.11 b/g Client/Server Data rate: up to 54 Mbps (Auto scaling)	64/128-bit WEP, WPA-TKIP and WPA2-AES

CAN to WiFi

Model Name	Interface	WiFi standard	Data Encryption
I-7540D-WF	CAN bus x 1 (CAN 2.0A/B) 3-wire RS-232 x 1 (configuration)	IEEE 802.11 b/g Client/Server Data rate: up to 54 Mbps (Auto scaling)	64/128-bit WEP, WPA-TKIP and WPA2-AES

LAN to WLAN Converter

Model Name	Interface	WiFi standard	Data Encryption
T-316	10/100M Ethernet	IEEE 802.11 b Client Data rate: 11 M, 5.5M, 1 Mbps (Auto scaling)	64/128-bit WEP

8-3 DSSS RF Products

DSSS RF (direct-sequence spread spectrum) is a modulation technique, which is the process of varying one or more properties of a high frequency periodic wave called the carrier signal, with respect to a modulating signal. The benefits of using DSSS include, but not limited to, 1) reduced signal/background-noise level hampers interception and 2) resistance to intended or unintended jamming.

ICP DAS provides SST series which is designed for data acquisition control applications between a host and remote sensors. It is also useful for those applications where the installation of cable wire is inconvenient.

Advantages & Benefits

- Full-duplex and Half-duplex up to 57600 bps
- Auto band-rate settings
- Direct sequence spread spectrum using RF technology
- Reduce wiring cost and inconvenience



• DSSS RF Selection Guide

Model Name	Frequency	Interface	Transmission Range
SST-900B	900 MHz (902-928 MHz)	RS-232/RS-485	Typical 700 m, Max. 1 km
SST-2450	2.4 GHz (2410.496 MHz ~ 2471.936 MHz)	RS-232/RS-485	300 m (Typical)

• Wireless Modem Network



8-4 2G/3G Products

ICP DAS 2G/3G wireless solutions are uniquely designed to meet the challenges of implementing and managing a small, medium and large number of unmanned remote devices as well as mobile terminals using the 2G/3G telecom network. The ICP DAS 2G/3G wireless system is comprised of intelligent 2G/3G modems with versatile interfaces, a 2G/3G Data Server (DS), and 2G/3G PACs with embedded dynamic IP resolution technology to help system integrators and application service providers can quickly integrate 2G/3G technology into their own solutions, and save development time with reduced costs and assured performance.

Advantages & Benefits

- There is no need to build an expensive fixed line network.
- Enable any devices to be connected to the Internet via serial port over a 2G/3G network.
- The most efficient method of handling data over a 2G/3G wireless network and the Internet.
- A full turnkey solution that is designed for both fixed and mobile machine to machine applications.
- Reliable GSM/GPRS/EDGE/UMTS/HSPA network connectivity, providing fast and cost-effective long-range wireless applications



GT-530 WISE-4000

2G/3G Selection Guide



Stand Alone Modem

Model Name	Frequency (MHz)	Reset Input	MIC Input/ Audio output	GPS	TCP/IP Stack	Baud Rate (bps)	Interface	Driver
GTM-201-RS232	2G (GSM/GPRS): 850/900/1800/1900	Yes	Yes	-	Yes	9.6K~115.2K	RS-232	Windows XP/7 Windows CE Linux
GTM-201-USB	2G (GSM/GPRS): 850/900/1800/1900	Yes	Yes	-	Yes	9.6K~115.2K	USB2.0	Windows XP/7 Windows CE Linux
GTM-201-3GWA	2G (GSM/GPRS): 850/900/1800/1900	Yes	Yes	-	Yes	9.6K~115.2K	USB2.0 RS-232	Windows XP/7 Windows CE Linux
	3G (UMTS/HSDPA/ HSUPA): 2100/1900/850							
GTM-201P-3GWA	2G (GSM/GPRS): 850/900/1800/1900	Yes	Yes	Yes	Yes	9.6K~115.2K	USB2.0 RS-232 GPS	Windows XP/7 Windows CE Linux
	3G (UMTS/HSDPA/ HSUPA): 2100/1900/850							



2G/3G Module for PACs

Model Name	Frequency (MHz)	GPS Interface	Max. Download Speed	AT Command	TCP/IP Protocol
I-8212W	2G (GSM/GPRS): 850/900/1800/1900	-	85.6 Kbps	Yes	Yes
I-8213W	2G (GSM/GPRS): 850/900/1800/1900	Yes	85.6 Kbps	Yes	Yes
I-8212W-3GWA	2G (GSM/GPRS): 850/900/1800/1900	-	9.6 ~ 115.2 Kbps	Yes	Yes
	3G (UMTS/HSDPA/HSUPA): 2100/1900/850				
I-8213W-3GWA	2G (GSM/GPRS): 850/900/1800/1900	Yes	9.6 ~ 115.2 Kbps	Yes	Yes
	3G (UMTS/HSDPA/HSUPA): 2100/1900/850				

• Intelligent 2G/3G Modules Selection Guide

Model Name	CPU	Interface	Frequency (MHz)	I/O	Alarm	Micro SD	Battery Backup	Communication
GT-530	32-bit	2 × RS-232	2G: 850/900/1800/1900	2 × DO 10 × DI	Yes (SMS)	Yes	Yes	SMS
GT-531	32-bit	2 × RS-232 1 × RS-485	2G: 850/900/1800/1900	-	Yes (SMS, Voice)	Yes	-	Modbus RTU server SMS
GT-534	32-bit	1 × RS-232 1 × RS-232/485	2G: 850/900/1800/1900	2 × DO 6 × DI 1 × AI	Yes (SMS, Voice)	Yes	Yes	SMS
GT-540	32-bit	1 × RS-232 1 × RS-485	2G: 850/900/1800/1900	2 × DO 6 × DI 1 × AI	Yes (GPRS)	Yes	-	GPRS Modbus RTU Client
GT-540P	32-bit	1 × RS-232 1 × RS-485 GPS	2G: 850/900/1800/1900	2 × DO 6 × DI 1 × AI	Yes (GPRS)	Yes	-	GPRS, GPS Modbus RTU Client
GT-541	32-bit	1 × RS-232 1 × RS-485	2G: 850/900/1800/1900	-	-	-	-	GPRS, VxComm
WISE-4000	16-bit	1 × Ethernet	2G: 850/900/1800/1900	3 × DO 3 × DI 8 × AI	-	-	-	SMS Modbus TCP server

• Mini PAC with 2G/3G Selection Guide

Model Name	OS	CPU	Flash/ RAM (KB)	Interface	I/O	Frequency (MHz)	Speed (Down/UP)	LCM (Dot)	GPS/ ZigBee
G-4500-2G	MiniOS7	80 MHz	512/512	1 × Ethernet 2 × RS-232 1 × RS-485	3 × DO 3 × DI 8 × AI	2G (GSM/GPRS): 850/900/1800/1900	85.6/42.8 kbps	-	-
G-4500D-2G	MiniOS7	80 MHz	512/512	1 × Ethernet 2 × RS-232 1 × RS-485	3 × DO 3 × DI 8 × AI	2G (GSM/GPRS): 850/900/1800/1900	85.6/42.8 kbps	128 × 64	-
G-4500P-2G	MiniOS7	80 MHz	512/512	1 × Ethernet 2 × RS-232 1 × RS-485	3 × DO 3 × DI 8 × AI	2G (GSM/GPRS): 850/900/1800/1900	85.6/42.8 kbps	-	GPS
G-4500PD-2G	MiniOS7	80 MHz	512/512	1 × Ethernet 2 × RS-232 1 × RS-485	3 × DO 3 × DI 8 × AI	2G (GSM/GPRS): 850/900/1800/1900	85.6/42.8 kbps	128 × 64	GPS
G-4500-3GWA	MiniOS7	80 MHz	512/512	1 × Ethernet 2 × RS-232 1 × RS-485	3 × DO 3 × DI 8 × AI	2G (GSM/GPRS): 850/900/1800/1900 3G (UMTS/ HSDPA/HSUPA): 2100/1900/850	7.2/5.76 Mbps	-	-
G-4500D-3GWA	MiniOS7	80 MHz	512/512	1 × Ethernet 2 × RS-232 1 × RS-485	3 × DO 3 × DI 8 × AI	2G (GSM/GPRS): 850/900/1800/1900 3G (UMTS/ HSDPA/HSUPA): 2100/1900/850	7.2/5.76 Mbps	128 × 64	-
G-4500P-3GWA	MiniOS7	80 MHz	512/512	1 × Ethernet 2 × RS-232 1 × RS-485	3 × DO 3 × DI 8 × AI	2G (GSM/GPRS): 850/900/1800/1900 3G (UMTS/ HSDPA/HSUPA): 2100/1900/850	7.2/5.76 Mbps	-	GPS
G-4500PD-3GWA	MiniOS7	80 MHz	512/512	1 × Ethernet 2 × RS-232 1 × RS-485	3 × DO 3 × DI 8 × AI	2G (GSM/GPRS): 850/900/1800/1900 3G (UMTS/ HSDPA/HSUPA): 2100/1900/850	7.2/5.76 Mbps	128 × 64	GPS

8-5 ZigBee Products

ZigBee is a specification based on the IEEE 802.15.4 standard for wireless personal area networks (WPANs). ZigBee operates in the ISM radio bands and its focus is to define a general purpose, inexpensive, self-organizing, mesh network that can be used for industrial control, embedded sensing, medical data collection, smoke and intruder warning, building automation, and home automation, etc.

Advantages & Benefits

- ISM 2.4 GHz operating frequency and fully compliant 2.4 G IEEE 802.15.4 ZigBee specifications
- Wireless transmission range up to 100m (Line of sight)
- Provide friendly GUI configuration software (Windows Version)
- Support three different types of ZigBee devices (Coordinator, Full function device, Reduced function device) in a ZigBee network.
- Support three topologies (MESH, STAR, CLUSTER TREE) defined in the IEEE 802.15.4



ZB-2043-T ZB-2060-T

• ZigBee Converter Selection Guide

Model Name	Interface	Module Type	Transmit Power	Antenna	Distance (LOS)
ZB-2550-T	1 × RS-232 1 × RS-485	Host	3 ~ 4 dBm	2.4GHz - 3dBi Omni-Directional antenna	100 m
ZB-2550-PA	1 × RS-232 1 × RS-485	Host	22 ~ 24 dBm	2.4GHz - 5dBi Omni-Directional antenna	700 m (Typical) 1 km (Max.)
ZB-2551-T	1 × RS-232 1 × RS-485	Slave	3 ~ 4 dBm	2.4GHz - 3dBi Omni-Directional antenna	100 m
ZB-2551-PA	1 × RS-232 1 × RS-485	Slave	22 ~ 24 dBm	2.4GHz - 5dBi Omni-Directional antenna	700 m (Typical) 1 km (Max.)
ZB-2570-T	1 × RS-232 1 × RS-485 1 × Ethernet	Host	3 ~ 4 dBm	2.4GHz - 3dBi Omni-Directional antenna	100 m
ZB-2570-PA	1 × RS-232 1 × RS-485 1 × Ethernet	Host	22 ~ 24 dBm	2.4GHz - 5dBi Omni-Directional antenna	700 m (Typical) 1 km (Max.)
ZB-2571-T	1 × RS-232 1 × RS-485 1 × Ethernet	Slave	3 ~ 4 dBm	2.4GHz - 3dBi Omni-Directional antenna	100 m
ZB-2571-PA	1 × RS-232 1 × RS-485 1 × Ethernet	Slave	22 ~ 24 dBm	2.4GHz - 5dBi Omni-Directional antenna	700 m (Typical) 1 km (Max.)

• ZigBee I/O Selection Guide

Model Name	Protocol	Input Channel	Output Channel	Transmit Power	Antenna	Distance (LOS)
ZB-2015-T	DCON Modbus RTU	6 × AI	-	4 dBm	2.4GHz - 3dBi Omni-Directional antenna	100 M
ZB-2018-T	DCON Modbus RTU	8 × AI	-	4 dBm	2.4GHz - 3dBi Omni-Directional antenna	100 M
ZB-2052-T	DCON Modbus RTU	8 × DI	-	4 dBm	2.4GHz - 3dBi Omni-Directional antenna	100 M
ZB-2053-T	DCON Modbus RTU	14 × DI	-	4 dBm	2.4GHz - 3dBi Omni-Directional antenna	100 M
ZB-2060-T	DCON Modbus RTU	6 × DI	4 × Relay Out	4 dBm	2.4GHz - 3dBi Omni-Directional antenna	100 M

8-6 GPS Products

GPS (Global Positioning System) is widely used for driving navigation, geographic monitoring, fleet management and cargo tracking, etc. We also can use GPS for industrial application according to its longitude and latitude value and UTC time. ICP DAS provides various modules for different applications. Some are pure GPS data receivers and some add DO channels. Some even can generate a UTC synchronized 1 PPS (Pulse Per Second) output signal. You can refer the following selection guide in chapter 5 to choose the suitable GPS modules for your application.

Advantages & Benefits

- Support up to 32-channel GPS and NMEM v0183 v3.01
- Apply for Automotive, Marine or Personal positioning and navigation
- Current time from Satellite
- Easy installation



● GPS Selection Guide

Model Name	GPS Channels	SBAS	GPS Output Interface	GSM/GPRS	Digital Output	Protocol/Interface	Description
GTM-201P-3GWA	32	WAAS, EGNOS, MSAS	USB/RS-232	Yes	-	-	GPS Receiver
GT-321R-USB	12	WAAS, EGNOS	RS-232	-	-	-	GPS Receiver
GT-321R-RS232	12	WAAS, EGNOS	USB	-	-	-	GPS Receiver
I-87211W	32	WAAS, EGNOS, MSAS	RS-232	-	2	DCON/*Note1	GPS Receiver and 2 DO Module
I-8213W	32	WAAS, EGNOS, MSAS	*Note2	Yes (TCP/IP protocol) *Note3	-	-	GPS Receiver and GPRS Controller Module
GPS-721	32	WAAS, EGNOS, MSAS	RS-232	-	1	DCON/RS-485	GPS Receiver and 1 DO Module

[*Note1] The support list of MCU (Main Control Unit) and I/O expansion unit are: XPAC, WinPAC, LinPAC, iPAC, ViewPAC, U-87P1/2/4/8, USB-87P1/2/4/8, I-8000, TI-8KE4/8, I-8KE4/8-MTCP, I-87K4/5/8/9

[*Note2] Gets GPS Information from Parallel bus (API). The support list of MCU: XPAC, WinPAC, LinPAC, iPAC, ViewPAC, etc.

[*Note3] Gets GSM/GPRS Information from Parallel bus (API). This GPRS/GSM module is integrated with the TCP/IP protocol, Extended TCP/IP AT commands. The support list of MCU : XPAC, WinPAC, LinPAC, iPAC, ViewPAC, etc.

8-7 Infrared Products

IR data transmission is employed in short-range communication among computer peripherals and personal digital assistants. These devices usually conform to standards published by IrDA.

ICP DAS has developed various IR products to apply in home automation. These IR products will help users to control and integrate these IR devices into a control system. Therefore, by integrating the PAC and others series of ICP DAS, users can easily to establish the home automation system.

Advantages & Benefits

- With RS-232 and RS-485 Interfaces
- Support Modbus/RTU protocol
- No special or proprietary hardware is required
- Easy to integrated with automation
- High noise immunity

IR-210



● Infrared Selection Guide

Model Name	Output	UART Interface	Protocol Support
IR-712	2 x IR Output channels	1 x RS-232 1 x RS-485	Modbus RTU
IR-210	6 x IR Output Channels	1 x RS-232 1 x RS-485	Modbus RTU
IR-310-RM	10 x High Power Relay Channels	1 x RS-232 1 x RS-485	Modbus RTU IR commands

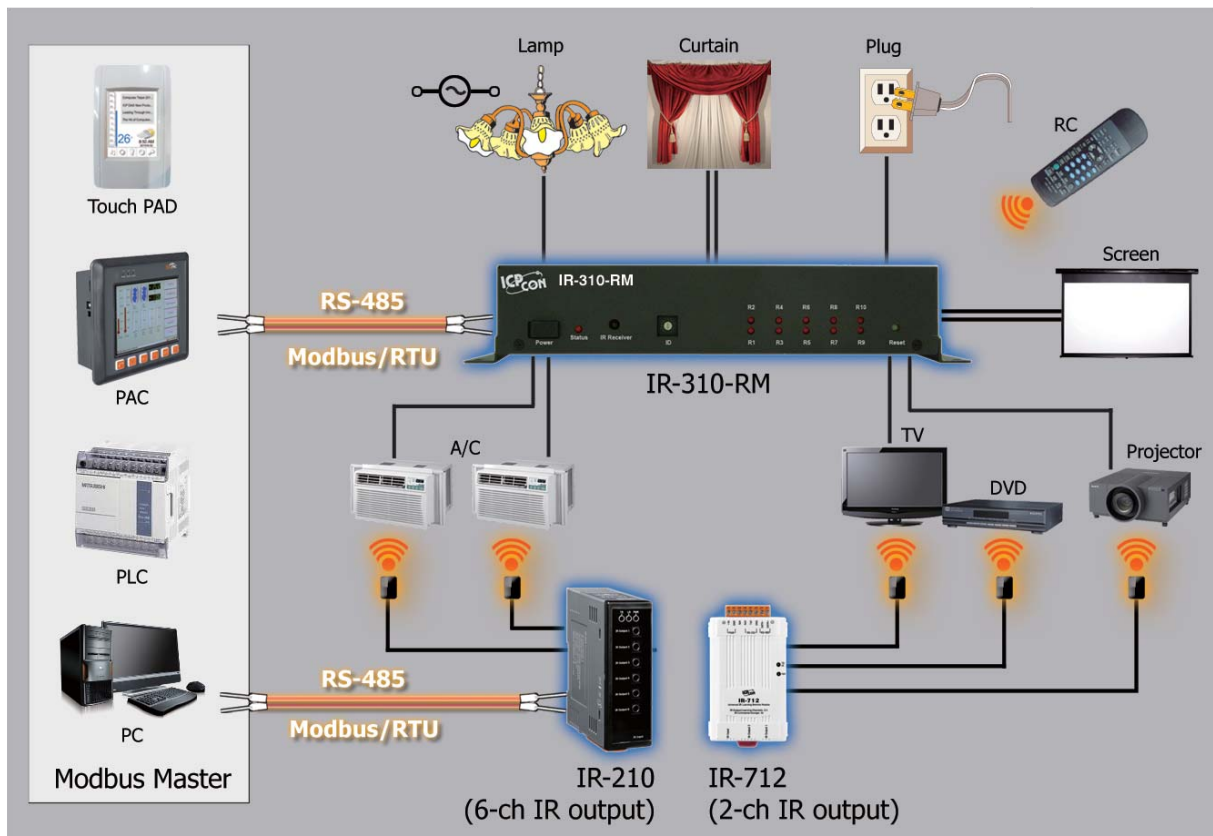

8-8 Wireless Applications

• PAC/PLC Remote Maintenance by 2G/3G Wireless Communication

These 2G/3G products are specially designed by ICP DAS for the PLC/PAC remote maintenance and upgrading the serial to network application solution. It is suitable for the harsh industrial field. This solution can transfer the site condition of equipment accurately. The maintenance engineer can directly check and diagnose the device/PLC like on-site. This can reduce the huge maintenance cost to increase the competition of enterprises. These PLC can be Siemens, Mitsubishi or Omron with RS485/RS232 communication port.



PLC Editor-Step 7

Model Name	CPU	Interface	Frequency	I/O	Transparent Communication
GT-541	32-bit	1 RS-232 1 RS-485 or RS-232	Quad-band 850/900/1800/1900 MHz GSM supporting GPRS	-	GPRS
G-4500L	32-bit (Linux)	COM1 (5-wire RS-232) COM2 (RS-485) COM3 (3-wire RS-232)	Tri-band 2100/1900/850 MHz WCDMA supporting	3 channel DI 3 channel DO 8 channel AI	UMTS/HSDPA/ HSUPA

Serial to Wireless Solution

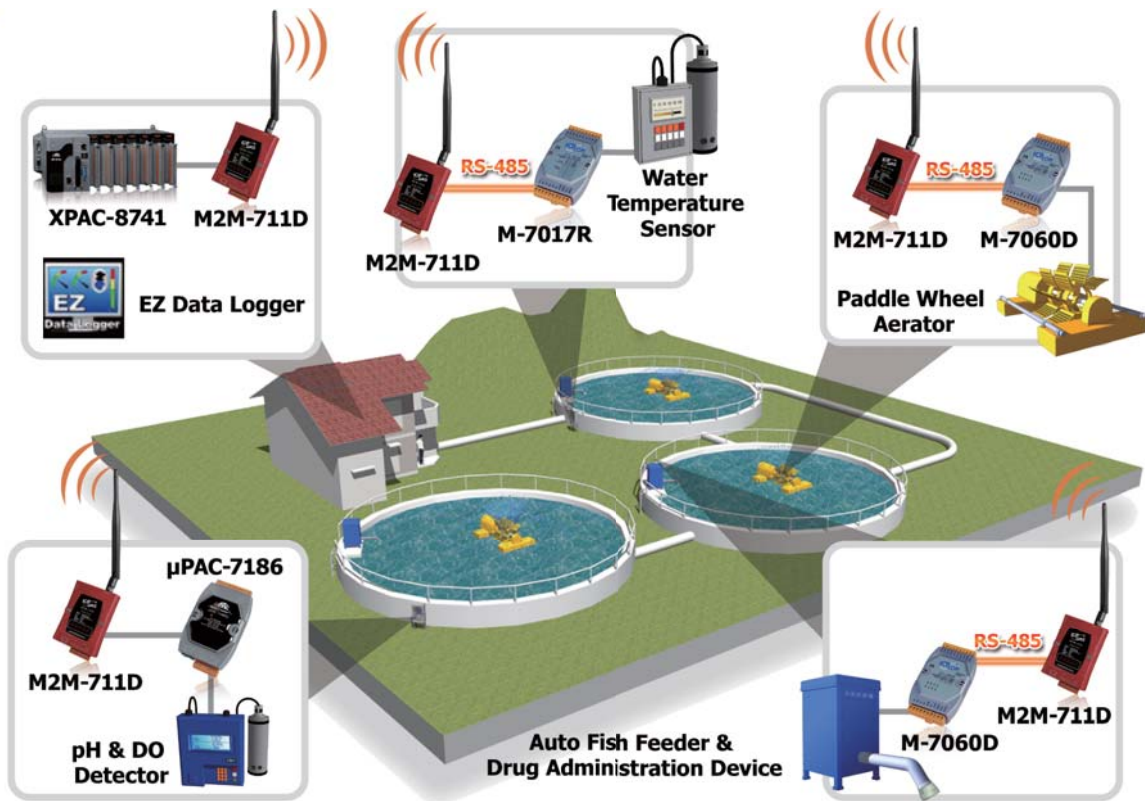

Setting up a fixed-line network on site is relatively complicated, makes the agricultural production technology underdeveloped, and left behind the state of the art in factories of manufactured products. The application shown above is a project aiming to improve the production process in fish farms using new perception, control and automation technologies. Simply converting serial signal to wireless allows fisher to monitor or control fish farm easily.

It is easy to convert serial RS-232/485 to a wireless product by wireless modems or with converters instead of running a wire. All of the following products allow you to convert a serial port to a wireless serial connection.

Model Name	Interface	Wireless
Serial to WLAN		
M2M-711D	RS-232 RS-485	Wi-Fi (802.11b/g)
Serial to DSSS RF		
SST-900B	RS-232 RS-485	DSSS RF (900 MHz)
SST-2450	RS-232 RS-485	DSSS RF (2.4 GHz)
Serial to ZigBee		
ZB-2550-T ZB-2550-PA	RS-232 RS-485	ZigBee Host (2.4 GHz)
ZB-2551-T ZB-2551-PA	RS-232 RS-485	ZigBee Slave (2.4 GHz)

• CAN bus Wireless Solution

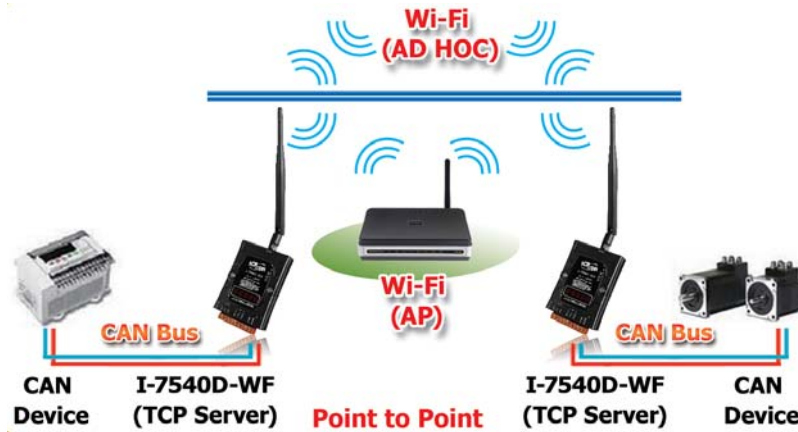

Controller Area Network (CAN) is a message-based protocol, designed specifically for automotive applications but now also used in other areas such as industrial automation and medical equipment. ICP DAS provides CAN to Wi-Fi product to support the wireless transmission of CAN data between various CAN networks or a CAN network and a WLAN network according to the 802.11b/g standard.

Model Name	Interface	Wireless
CAN to WLAN		
I-7540D-WF	CAN/RS-232	Wi-Fi (802.11b/g)

• Ethernet to Wireless Solution

Ethernet is a family of computer networking technologies for local area networks (LANs) commercially introduced in 1980 and has become the public wired network in commerce or industry field. It has great benefits and extends the Ethernet application if wireless technology can be applied in Ethernet application. According to this issue, we develop Ethernet/WiFi and Ethernet/ZigBee for users to apply in their Ethernet application.

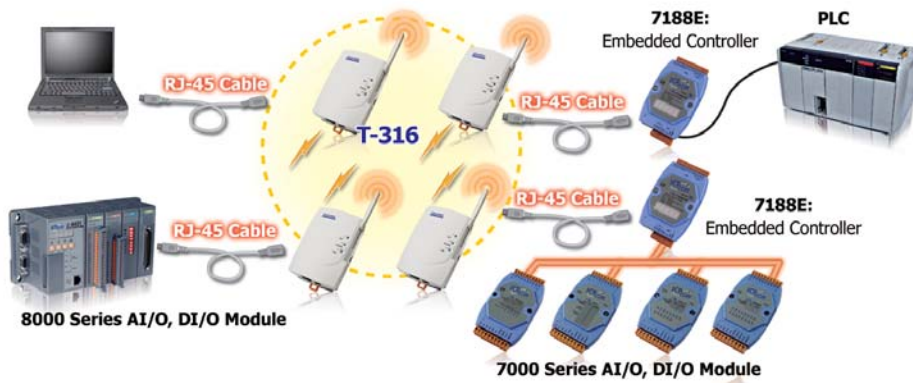

Model Name	Interface	Wireless
Ethernet to WLAN		
T-316	Ethernet	Wi-Fi (802.11b/g)
Ethernet to ZigBee		
ZB-2570-T ZB-2570-PA	Ethernet	ZigBee Host (2.4 GHz)
ZB-2571-T ZB-2571-PA	Ethernet	ZigBee Slave (2.4 GHz)

Model Index

Model Name	Page
C	
CA-0903	7-1-1
CA-090910	7-1-1
CA-0910	7-1-1
CA-0910-C	5-2-13
CA-0910F	7-1-1
CA-0915	7-1-1
CA-4002	7-3-1
CA-9-2505D	7-1-2
CA-9-3705	7-1-2
CA-9-3715D	7-1-2
CA-PC09F	7-3-1
CA-USB18	7-1-2
CNT-CAN	5-2-13
CNT-PROFI	5-6-4
D	
DIN-KA52F	7-2-1
DIN-KA52F-48	7-2-1
DN-09-2	7-3-1
DN-09-2F	7-3-1
DR-120-24	7-3-1
DR-120-48	7-3-1
DS-712	3-3-1
DS-715	3-3-3
G	
G-4500 series	8-4-2
G-4500L	8-8-1
GPSU06U-6	7-2-1
GPSU06E-6	7-2-1
GPS-721	8-6-1
GT-321R-USB	8-6-1
GT-321R-RS232	8-6-1
GT-530	8-4-2
GT-531	8-4-2
GT-534	8-4-2
GT-540(P)	8-4-2
GT-541	8-4-2
GTM-201 series	8-4-1
GTM-201(P)-3GWA	8-4-1
GW-5492	5-9-2
GW-5493	5-9-3
GW-7228	5-5-2
GW-7238D	5-5-2
GW-7243D	5-4-3
GW-7433D	5-3-3
GW-7434D	5-4-3
GW-7472	5-8-3
GW-7552	5-6-4
GW-7553	5-6-4
GW-7557	5-6-4
H	
HART-710	5-7-2

Model Name	Page
I	
I-2532	5-2-4
I-2533	5-2-4
I-2534	5-2-5
I-2541	4-7-1
I-2542 series	4-7-1
I-7188XBD-CAN	5-2-8
I-7231D	5-3-3
I-7232D	5-3-3
I-7241D	5-4-4
I-7242D	5-4-4
I-7510 series	4-2-3
I-7514U	4-3-1
I-7520 series	4-4-7
I-7520U4	4-4-3
I-752N series	4-5-1
I-7530	5-2-6
I-7530A	5-2-6
I-7530A-MR	5-2-6
I-7530-FT	5-2-6
I-7531	5-2-5
I-7532	5-2-5
I-7540D	5-2-6
I-7540D-MTCP	5-2-7
I-7540D-WF	5-2-7
I-7550	5-6-3
I-7551	4-4-9
I-7560	4-6-3
I-7561	4-6-7
I-7563	4-6-9
I-7565	5-2-7
I-7565-CPM	5-3-4
I-7565-DNM	5-4-4
I-7565-H1	5-2-7
I-7565-H2	5-2-7
I-7567	5-7-3
I-7570	5-7-3
I-8112iW	3-5-6
I-8114W	3-5-8
I-8114iW	3-5-8
I-8120W	5-2-8
I-8123W	5-3-4
I-8124W	5-4-4
I-8142iW	3-5-10
I-8144iW	3-5-10
I-8212W	8-4-1
I-8213W	8-4-1
I-87120	5-2-8
I-87123	5-3-4
I-87124	5-4-4
I-87211W	8-6-1
I-87H17W	5-7-2

Model Name	Page
I	
I-87H24W	5-7-2
IR-210	8-7-1
IR-310-RM	8-7-1
IR-712	8-7-1
K	
KA-52F	7-2-1
KA-52F-48	7-2-1
M	
M2M-711D	8-8-2
MDR series	7-2-1
MSM-508	6-2-3
MSM-508F series	6-2-4
MSM-6226	5-8-3, 6-2-4
MSM-6226G	6-2-4
N	
NS-200AF series	6-2-4
NS-200SX/NS-200LX	6-2-4
NS-200WDM series	6-2-4
NS-205(A)	6-2-1
NS(M)-205AF series	6-2-1
NS-205G	6-2-1
NS-205-IP67	6-2-2
NS(M)-205PF series	6-2-2
NS-205PSE(-24V)	6-2-2
NS(M)-206AF series	6-2-2
NS(M)-208A	6-2-1
NS(M)-208AG	6-2-1
NS(M)-208G	6-2-1
NS(M)-208PSE	6-2-3
NS(M)-208PSE-4	6-2-2
NS(M)-209F series	6-2-2
P	
PCISA-7520AR	4-4-5
PCISA-7520R	4-4-5
PCM-CAN100	5-2-9
PCM-CAN200	5-2-9
PCM-CAN200P	5-2-9
PCM-CM100	5-2-9
PDS-220Fx series	3-6-1
PDS-5105D-MTCP	3-8-1
PDS(M)-700 series	3-2-1
PDS-811	3-5-2
PDS-821	3-5-2
PDS-842	3-5-4
PDS-882	3-5-4
PEX-CAN200i series	5-2-9
PISO-CAN100U series	5-2-10
PISO-CAN200U series	5-2-10
PISO-CAN400U series	5-2-10
PISO-CAN800U series	5-2-10
PISO-CM100U series	5-2-10
PISO-CPM100U series	5-3-4
PISO-CPS100U series	5-3-4
PISO-DNM100U series	5-4-5
PISO-DNS100U series	5-4-5

Model Name	Page
P	
PM-2133-CAN series	5-2-10
PM-2134-CAN series	5-2-10
PPDS(M)-700-MTCP series	3-2-1
PPDS-700-IP67 series	3-4-1
PPDS-712-MTCP	3-3-1
PPDS-715-MTCP	3-3-3
PROFI-2510	5-6-2
PROFI-2541	5-6-3
R	
RS(M)-405 series	6-2-3
RS(M)-405F series	6-2-3
RS(M)-408 series	6-2-3
S	
SST-2450	8-3-1
SG-770	5-2-6
SST-900B	8-3-1
T	
T-316	8-2-1
tDS-700 series	3-7-1
tM-7510U	4-2-1
tM-7520U	4-4-1
tM-752N series	4-5-5
tM-7561	4-6-5
tGW-700 series	3-7-4
U	
USB-2512	4-6-1
USB-2514	4-6-1
USB-2560	7-4-1
USB-4518	4-6-1
uPAC-7186EXD-CAN	5-2-8
uPAC-7186EX(D)-MTCP	3-9-1
V	
VEX-112 series	2-2-1
VEX-114 series	2-2-2
VEX-118 series	2-2-7
VEX-142 series	2-2-3
VEX-144 series	2-2-4
VEX-148-5w series	2-2-8
VXC-112 series	2-2-1
VXC-114 series	2-2-2
VXC-118U series	2-2-7
VXC-142 series	2-2-3
VXC-144 series	2-2-4
VXC-148U-5w series	2-2-7
VXC-164AU series	2-2-6
VXC-182iU	2-2-5
W	
WISE-4000(D)	8-4-2
Z	
ZB-2000 series	8-5-1

ICP DAS Catalogs

Compact PAC Products Catalog

- XP-8000-Atom Series
- XP-8000 Series
- WP-8000 Series
- LP-8000 Series
- iP-8000 Series
- ViewPAC Series
- MotionPAC Series
- I/O Expansion Units
- I/O Modules
- 7188/7186 Series
- 5000 Series



Industrial Remote I/O Products Catalog

- RS-485 Remote I/O Modules
- Ethernet Remote I/O Modules
- FRnet I/O Modules
- CAN bus Remote I/O Modules
- PROFIBUS Remote I/O Modules



Touch HMI Devices Brochure

- 2.8" high-color LCD touch screen
- 3.5" high-color LCD touch screen
- 4.3" high-color LCD touch screen
- RS-232, RS-485 or Ethernet Interface
- HMIWorks development software
- Modbus TCP, Modbus RTU and DCON protocols
- Standard C or Ladder programming



Industrial Data Acquisition for ISA and PCI Bus Full Catalog

- Multi-port Serial Communication Boards
- CAN bus Communication Boards
- PCI/ISA Data Acquisition and I/O Boards
- PCI bus Battery-Backup Memory Boards
- Daughter Boards & Accessories
- Motion Control & Watchdog Boards
- Signal Conditioning & Power Modules
- FRnet Remote I/O Products
- LED Display



High Reliability Industrial Ethernet Switch Catalog

- Managed Ethernet Switches
- Unmanaged Ethernet Switches
- PoE Ethernet Switches
- Media Converters
- Real-time Redundant Ring Ethernet Switches
- IP67 Waterproof Switches
- Cyber-Ring Ethernet Self-healing Technology



New Members in I/O Cards Short Form

- PCI Express Cards
- Universal PCI Cards
- Analog Input and Output Cards
- Digital Input and Output Cards
- Multi-port Serial Cards



Fieldbus Solutions Full Catalog

- CAN Bus Communication Products
- CANopen Communication Products
- DeviceNet Communication Products
- J1939 Communication Products
- PROFIBUS Communication Products
- HART Communication Products
- Ethernet/IP Communication Products
- BACnet Communication Products



Industrial Wireless Communication Products

- Industrial Wireless Series
- DSSS RF Modems
- 2G/3G Mini-PAC/Modules/Modems
- ZigBee Converters & I/O Modules
- GPS Solutions



Industrial CAN bus Products Catalog

- CAN Converters, CAN Repeater, CAN Bridge, CAN Switch, CAN Cards, Surge Protector, PACs, CAN Expansion Modules, CAN Power Meters, CAN Connector, CAN Transformation Cable
- CANopen Gateways, CANopen Master Interfaces, CANopen Remote I/O Modules
- DeviceNet Gateways, DeviceNet Master Interfaces, DeviceNet Remote I/O Modules
- J1939 Gateways



M2M Total Solutions

- 2G/3G Solutions
- WLAN Solutions
- Remote Maintenance Solutions
- DSSS RF/GPS Solutions
- M2M Series Selection Guide





ICP DAS CO., LTD.

Taiwan (Headquarters)

Website: <http://www.icpdas.com>

E-mail: sales@icpdas.com

TEL: +886-3-597-3366

FAX: +886-3-597-3733

China

Website: <http://www.icpdas.com.cn>

E-mail: sales_sh@icpdas.com.cn

TEL: +86-21-6247-1722

FAX: +86-21-6247-1725

Europe

Website: <http://www.icpdas-europe.com>

E-mail: info@icpdas-europe.com

TEL: +49(0)7121-14324-0

FAX: +49(0)7121-14324-90

USA

Website: <http://www.icpdas-usa.com>

E-mail: sales@icpdas-usa.com

TEL: +1-310-517-9888

FAX: +1-310-517-0998

Local Distributor

