



Industrial

# Fieldbus

Product Catalog

Vol. IFB 2.05.06



Website: <http://www.icpdas.com>

# Table of Contents

## Introduction

# 1



1.1 Overview	1-1
1.2 Related PAC	1-2
1.3 Related Panel	1-6
1.4 Industrial Wireless Communication Products	1-7

## RS-485 Products

# 2



2.1 Communication Cards for PC/IPC	2-1
2.2 Communication Modules for PAC	2-2
2.3 Converter/Repeater/Hub/Splitter	2-3
2.4 Termination Resistor/DC Bias Voltage	2-5
2.5 RS-485 I/O Modules	2-6
2.6 RS-485 I/O Units	2-7

## Industrial Ethernet Products

# 3



3.1 Overview	3-1
3.2 EtherCAT Products	3-2
▶ Selection Guide	3-2
3.3 EtherNet/IP Products	3-6
▶ Selection Guide	3-6
▶ EtherNet/IP Remote I/O Modules	3-9
3.4 PROFINET Products	3-10
▶ Selection Guide	3-11
▶ PROFINET Converters	3-12
▶ PROFINET Gateways	3-13
▶ Analog Input & Output Modules	3-15
▶ Digital Input & Output Modules	3-16
3.5 Ethernet Device Servers	3-17
▶ Introduction	3-17
▶ Selection Guide	3-18
3.6 BACnet/IP Products	3-19
▶ Selection Guide	3-19
▶ Case Studies	3-20
▶ BACnet Gateways	3-21
▶ BACnet/IP I/O Modules	3-22
3.7 Industrial Ethernet/Fiber Switches	3-23
3.8 Ethernet I/O Modules (Modbus TCP/UDP Slave)	3-28
▶ Selection Guide	3-31
3.9 MQTT I/O Module	3-33
▶ Selection Guide	3-33
3.10 Wi-Fi Products	3-34
▶ Selection Guide	3-34
▶ Wi-Fi Converter	3-35
▶ Wi-Fi Bridge	3-35
▶ WLAN Remote Maintenance Device	3-36
▶ Wi-Fi Gateway	3-36
▶ Wi-Fi I/O Modules	3-37

## CAN Bus Products

# 4



4.1 Overview	4-1
4.2 CAN Bus Repeater/Bridge/Switch	4-4
4.3 CAN Converters	4-7
▶ 4.3.1 USB to CAN Converters	4-7
▶ 4.3.2 CAN to Fiber Converter/Bridge	4-11
▶ 4.3.3 Ethernet/Wi-Fi to CAN Converters	4-15
▶ 4.3.4 Uart to CAN Converters	4-20
4.4 Gateway/Protocol Converters	4-25
▶ 4.4.1 CANopen Gateways	4-25
▶ 4.4.2 CANopen Motion Solution	4-28
▶ 4.4.3 DeviceNet Gateways	4-29
▶ 4.4.4 J1939 Gateways	4-32
4.5 Palm-size Programmable CAN Controllers	4-35
4.6 PC-based CAN Bus Boards	4-36
4.7 PAC-based CAN Modules	4-41
4.8 CAN Bus Power Meter	4-42
4.9 CAN Bus Data Logger	4-44
4.10 I/O Modules and Units	4-46
▶ 4.10.1 Analog Input Modules	4-48
▶ 4.10.2 Analog Output Modules	4-49
▶ 4.10.3 Digital I/O Modules	4-50
▶ 4.10.4 CANopen I/O Units	4-51
▶ 4.10.5 DeviceNet I/O Units	4-52
▶ 4.10.6 I/O Module Support List of CAN-8000 Units	4-53
4.11 CANcheck	4-54
4.12 Case Studies	4-56

## PROFIBUS Products

# 5



5.1 Overview	5-1
5.2 PROFIBUS Converters & Repeaters	5-3
5.3 PROFIBUS Gateways	5-8
5.4 PROFIBUS Remote I/O Modules	5-11
5.5 PROFIBUS Remote I/O Units	5-13
5.6 Case Studies	5-15

## HART Products

# 6



6.1 Overview	6-1
6.2 HART System Integration Solution	6-2
6.3 HART Products	6-3
6.4 Case Studies	6-11

## M-Bus Products

# 7



7.1 Overview	7-1
--------------	-----

# Introduction



1.1	Overview	P 1-1
1.2	Related PAC	P 1-2
1.3	Related Panel	P 1-6
1.4	Industrial Wireless Communication Products	P 1-7



## 1.1 Overview

1

Introduction

Fieldbus is known as family of industrial network protocols for real-time distributed control. An automated industrial system usually requires Fieldbus solutions in order to overcome connectivity issues between the various, such as controllers, sensors and actuators. Fieldbus works on a network structure which typically allows daisy-chain, star, ring, branch, and tree type network topologies, providing a range of major advantages to all kinds of automation applications.

In order to provide a variety of Fieldbus solutions, ICP DAS has devoted signification resources for many years into developing Fieldbus products based on different protocols. In additional to Modbus TCP, Modbus RTU and Modbus ASCII, these products comprehensively cover the majority of industrial communication protocols, such as CAN Bus, CANopen, DeviceNet, J1939, PROFIBUS, HART, EtherCAT, Ethernet/IP, BACnet/IP, and PROFINET, for process and factory automation, as illustrated.



ICP DAS also offers a diverse range of PACs incorporating different sizes and features. These powerful PACs provide a method of assembling private protocols based on RS-232, RS-485, industrial Ethernet, CAN bus, Wi-Fi, 2.5G and 3G interfaces. By using a PAC, it is possible to integrate various communication protocols into a single controller, meaning that constructing a multi-function automation system becomes quicker and easier.







## 1.2 Related PAC

The PAC family of ICP DAS is a modular network-based PAC with the capability of connecting I/O either through its own dual backplane bus or alternatively through remote I/O units and remote I/O modules. This new exciting PAC family offers a flexible, versatile and economical solution to a wide range of applications from data acquisition, process control, test and measurement, motion control to energy and building management. Our PAC family includes XPAC, WinPAC, ViewPAC, LinPAC, iPAC, ViewPAC, Motion PAC and  $\mu$ PAC for different requirements in OS, CPU and development platform.

### PAC family

Compact PAC	XP-9000-WES7	WP-9000-CE7
Pictures		
OS	WES7	WinCE 7.0
Software Development Tool	VS .NET 2008, VC6, VB6, Delphi, BCB	VS .NET 2008 Win-GRAF, InduSoft
CPU	Intel E3827 (1.75 GHz dual-core)	Cortex-A8 (1 GHz)
I/O Expansion	I/O Slots (for I-9K modules), RS-232/485, Ethernet	

Compact PAC	XP-8000	XP-8000-CE6	WP-8000	iP-8000
Pictures				
OS	WES 2009	WinCE 6.0	WinCE 5.0	MiniOS7
Software Development Tool	VS .NET 2005/2008, VC6, VB6, Delphi, BCB	VS .NET 2005/2008 ISaGRAF, InduSoft	VS .NET 2005/2008 ISaGRAF, InduSoft	C language, ISaGRAF
CPU	AMD LX800 (500 MHz)	AMD LX800 (500 MHz)	Marvell PAX270 (520 MHz)	80186 (80 MHz)
I/O Expansion	I/O Slots (for I-8K and I-87K modules), RS-232/485, Ethernet			

$\mu$ PAC	WP-5231	WP-5000	$\mu$ PAC-5000	I-7188E	I-7188XA/B/C
	LP-5231	LP-5000		uP-7186E	
Pictures					
OS	WinCE 7.0 Linux kernel 3.2.14	WinCE 5.0 Linux kernel 2.6	MiniOS7	MiniOS7	MiniOS7
Software Development Tool	VS .NET 2008 Win-GRAF, InduSoft	VS .NET 2005/2008 ISaGRAF, InduSoft	C language, ISaGRAF	C language, ISaGRAF	C language, ISaGRAF
CPU	Cortex-A8 (1 GHz)	Marvell PXA270 (520 MHz)	80186 (80 MHz)	80186 (80 MHz) 80188 (40 MHz)	80188 (40 MHz)

**Software Development Tool**

**1. Win-GRAF (PAC / Soft PLC Development Kit)**

Win-GRAF is a powerful SoftLogic development software and PLC-like SoftLogic package that supports IEC 61131-3 Standard Open PLC Languages running on Windows 7 and Windows 8. The Win-GRAF Runtime application can run on any ICP DAS PAC (Programmable Automation Controller) that supports the Win-GRAF, such as the WinPAC series WP-8xx8, WP-5xx8 and WP-9xx8-CE7, or the touch panel ViewPAC series VP-1238-CE7, VP-2208-CE7 and VP-4208-CE7, or the advanced CPU XPAC-CE6 series XP-8xx8-CE6. Using the Win-GRAF software with ICP DAS Win-GRAF PACs, the control/monitor systems can easily implement industrial level of data acquisition and logic control in various industry fields.



**Win-GRAF Workbench Features:**

**Support IEC 61131-3 Standard Open PLC Languages:**

1. Ladder Diagram (LD)
2. Function Block Diagram (FBD)
3. Sequential Function Chart (SFC)
4. Structured Text (ST)
5. Instruction List (IL)

**Using ST Syntax in the FBD or LD Program**

**On Line Debug/Control/Monitor**

**Off Line Simulation on PC**

**On-Line Change:**

Replace the current running project to a new modified one without stopping the project

**Event Triggered Data Binding:**

Exchange data between PACs.

**Upload Source Code From PAC to PC**

**Recipe:**

Apply multi-recipes pre-defined in PC/Win-GRAF to PAC.

**Spy List:**

Show several selected variables in one Spy List window.

**Event triggered Data Binding**

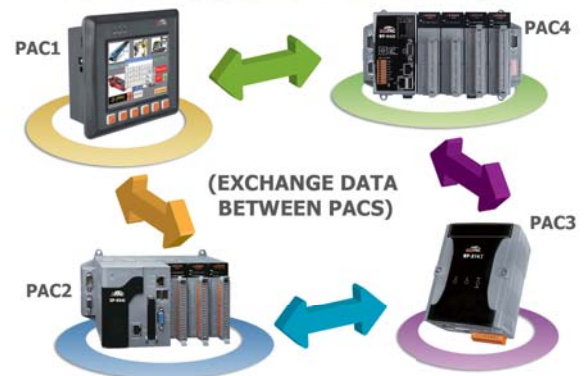

**2. ISaGRAF (SoftPLC Solution)**

ISaGRAF is a powerful SoftLogic package on the industrial market. ISaGRAF Workbench is a PLC-like development software running on Windows 95/98/NT/2000/XP/Vista/7 and its ISaGRAF Runtime application programs can run on any ISaGRAF PACs such as WP-8xx7, VP-2xx7, XP-8xx7-CE6, iP-8xx7, μPAC-7186(P)EG etc. Using ISaGRAF PACs, the control/monitor systems can easily implement industrial level of real-time data acquisition and data/devices control via wiring or wireless network in various industries.

**ISaGRAF Workbench Features:**

**Support IEC 61131-3 Standard Open PLC Languages**

+ Flow Chart (FC) :

1. Quick Ladder (LD)
2. Function Block Diagram (FBD)
3. Sequential Function Chart (SFC)
4. Structured Text (ST)
5. Instruction List (IL)
6. Flow Chart (FC)

**On-line debugging/control/monitor**

**Off-line simulation**

**On-line change (For WP-8xx7, VP-2xW7, XP-8xx7-CE6 only)**

**Spotlight: Simple graphic HMI**

**Auto-Scan I/O**

**Uploading the program in the PAC**

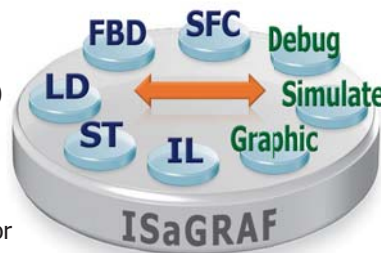

### 3. NAPOPC DA Server

**NAPOPC DA Server** is a **free** OPC DA Server (**The "OPC" stands for "OLE for Process Control" and the "DA" stands for "Data Access"**) provided by ICP DAS running on WinPAC, ViewPAC, XPAC, WinCon and PC with Windows 95/98/ME/2000/NT/XP operating systems. **NAPOPC DA Server** provides many benefits to users such as reduce time through lower system integration costs, integrate easily with plug-and-play SCADA/HMI/Database, connect and interoperate easily to custom applications, access to data by anyone in the automation hierarchy, reduce troubleshooting and maintenance cost, write to devices synchronously and asynchronously (not possible before OPC).

Using SCADA/HMI/Database software program, system contacts and obtains data from NAPOPC DA Server either on the same computer or on another computer. SCADA/HMI/Database makes a request and NAPOPC DA Server fulfills the request by gathering the data of ICP DAS modules and third-party devices to SCADA/HMI/Database.

For different OS of PAC products, ICP DAS provides several professional DA Servers, such as:

- NAPOPC\_ST DA Server : For Windows 95/98/2000/NT/XP/7 OS
- NAPOPC\_XPE DA Server : For Windows XP Embedded OS
- NAPOPC\_CE5 DA Server : For Windows CE 5.0 OS
- NAPOPC\_CE6 DA Server. : For Windows CE 6.0 OS

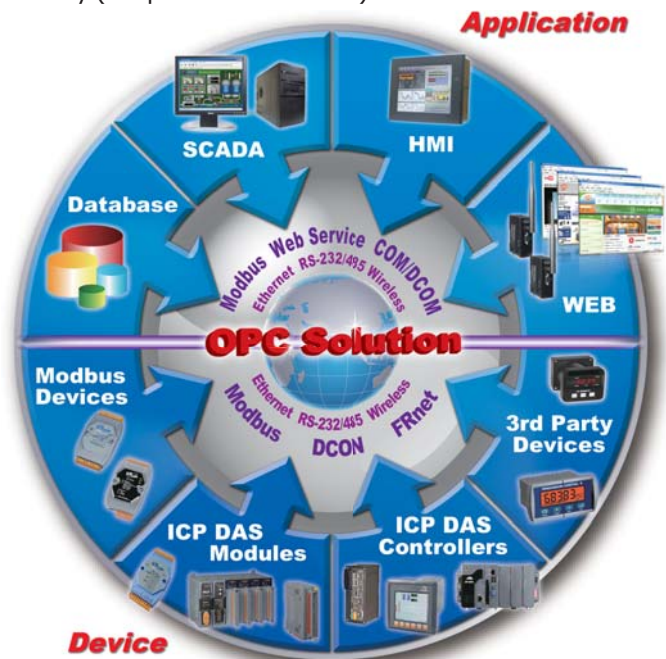

### 4. Soft-GRAF HMI

Soft-GRAF Studio is an HMI (Human Machine Interface) software developed by ICP DAS which allows user to create his colorful HMI application running with the control logic in the same ISaGRAF WinCE series PAC: XP-8047-CE6/8347-CE6/8747-CE6, WP-8137/8437/8837, WP-8147/8447/8847 and VP-25W7/23W7 ISaGRAF PAC. User can edit the HMI screen by Soft-GRAF Studio using the graphical drag and drop operation. And use ISaGRAF to design the control logic by PLC Languages (Ladder, ST, FBD.....).

#### • Soft-GRAF Studio Features:

- ▶ Soft-GRAF Studio:
  - Easy HMI screen editing (Mouse drag and drop) No programming is required to implement HMI editing.
- ▶ Support various and colorful HMI objects:
  - Page (Max. 200, support password security)
  - Numeric (Input, input security, display)
  - Text (Dynamic/static text display)
  - Picture (Animated/static picture display)
  - Moving Trace (1-axis or 2-axis)
  - Bar-meter (Vertical/horizontal dynamic display)
  - Buttons displayed as text
  - Buttons displayed as Picture
  - Built-in various objects (Will be more)
- ▶ Multi-language:
  - English, Traditional Chinese, Simplified Chinese, Russian, etc.
- ▶ HMI behaves smoothly



**5. InduSoft (SCADA Solution)**



**Introduction :**

InduSoft Web Studio is a powerful, integrated collection of automation tools that includes all the building blocks needed to develop modern Human Machine Interfaces (HMI), Supervisory Control and Data Acquisition (SCADA) systems, and embedded instrumentation and control applications.

InduSoft Web Studio's application runs in native Windows NT, 2000, XP, CE and CE .NET environments and conforms to industry standards such as Microsoft .NET, OPC, DDE, ODBC, XML, and ActiveX. We provide the InduSoft bundled driver to integrate InduSoft software into ICP DAS products (IO Modules: I-7000, I-8000, I-87K ; PACs: WinPAC, WinPAC, XPAC) for SCADA system.

**Integrated with ICP DAS PACs :**

InduSoft has been integrated into ICP DAS various PACs including WinPAC, ViewPAC, XPAC and XPAC-CE6. The following is the advantages when using InduSoft with ICP DAS PACs.

	Features
<b>WinPAC</b>	<ul style="list-style-type: none"> <li>• Stable and high performance-to-price ratio small SCADA system</li> <li>• Rapidly and easily develop I/O integrated graphic supervisory control system</li> </ul>
<b>ViewPAC</b>	<ul style="list-style-type: none"> <li>• Provide integrated touch HMI/SCADA system solution</li> <li>• Suitable for spatial narrow and small machine control system</li> </ul>
<b>XPAC</b>	<ul style="list-style-type: none"> <li>• High performance and various Win32 API and Tool integrated SCADA system</li> <li>• Easily integrate third party software for multi-purpose application</li> </ul>
<b>XPAC-CE6</b>	<ul style="list-style-type: none"> <li>• Provide the best choice for high efficiency real time embedded system</li> <li>• Suitable for massive data acquisition and processing centralized system</li> </ul>

**Features:**

- Elegant Graphics
- Multi-Language
- Database (Access, Excel, SQL, Oracle...)
- Recipes and Reports
- Online and History Alarm / Trend
- Various Communication Driver (DCON, Modbus, OPC, DDE, TCP/IP...)
- Remote Web Client Control & Security
- ActiveX (GSM / SHM / COM /WEB provided by ICP DAS)
- System Redundancy
- Others (VBScript, E-mail, FTP, SNMP...)

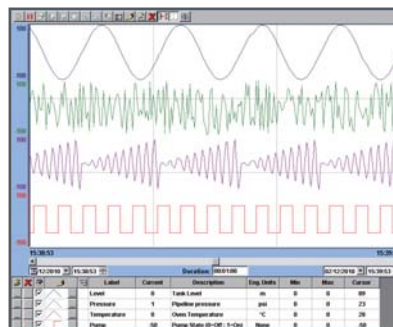
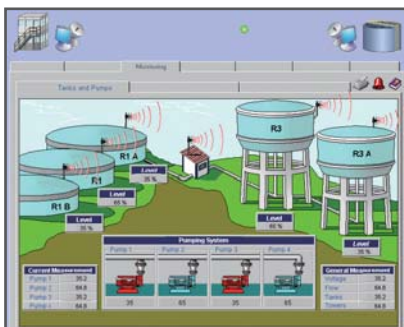
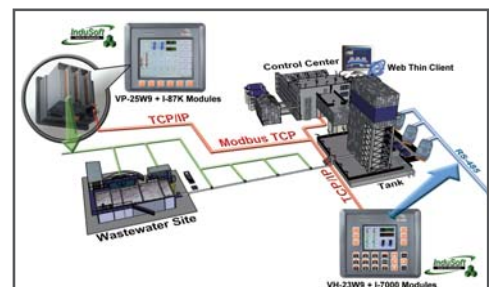
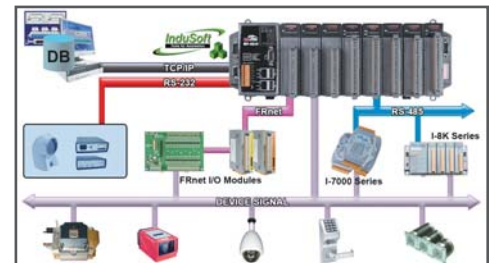
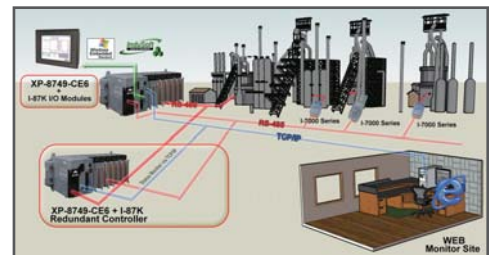











## 1.3 Related Panel

ICP DAS provides wide range of panel products, such as iPPC series, ViewPAC series, SmartView series, IWS (InduSoft) series, TouchPAD, and ViewPAD series. The iPPC series is an industrial panel PC based on WES7 (Windows Embedded Standard 7) and equipped with X86 CPU. The ViewPAC series is a panel PAC based on Windows CE and equipped with ARM CPU. The SmartView series is a kind of ViewPAC including web HMI, OPC UA and MQTT. The IWS series is an InduSoft based ViewPAC. TouchPAD and ViewPAD are control panel and equipped with ARM CPU.

### PAC family with LCD

	iPPC (Industrial Panel PC)	
Model Name	iPPC-x731-WES7	iPPC-x701-WES7
Pictures		
OS	WES7 (Windows Embedded Standard 7)	
Software Development Tool	DLL for Visual Studio .NET	
CPU	E3827 (1.75 GHz, 64-bit dual core)	
LCD	10.4" ~ 17"	
I/O Expansion	I/O Slots (for I-8K, I-87K modules), RS-232/485, Ethernet	RS-232/485, Ethernet

	ViewPAC			IWS	SmartView
Model Name	VP-25W1	VP-4131	VP-x201-CE7/VP-x231-CE7	IWS-x201-CE7	SV-x201
Pictures					
OS	WinCE 5.0		WinCE 7.0		Linux
Software Development Tool	VS .NET 2005/2008 ISaGRAF, Win-GRAF, InduSoft			InduSoft (SCADA)	Creator
CPU	Marvell PXA270 (520 MHz)		Cortex-A8 (720 MHz or 1 GHz)		
LCD	5.7"/10.4" TFT LCD with Touch Panel		7" ~ 15" TFT with Touch Panel		
I/O Expansion	I/O Slots (for I-8K, I-87K modules), RS-232/485, Ethernet			RS-232/485, Ethernet	

	TouchPAD			ViewPAD	
Model Name	TPD-703 TPD-703-64	TPD-43x	TPD-280-H TPD-283-H	VPD-13x VPD-13xN	VPD-14x VPD-14xN
Pictures					
OS	N/A				
Software Development Tool	HMIWorks (C language, Ladder)				
CPU	32-bit RISC CPU				
LCD	7" TFT LCD with Touch Panel	4.3" TFT LCD with Touch Panel	2.8" TFT LCD with Touch Panel	3.5" TFT LCD with Touch Panel	4.3" TFT LCD with Touch Panel
I/O Expansion	RS-232/485 or Ethernet		RS-485 or Ethernet	RS-232/485, Ethernet or XV-Board	

## 1.4. Industrial Wireless Communication Products

Industrial Wireless Communication creates new prospects for automation. In the harsh environment, chemicals, vibrations, or moving parts could potentially damage cabling. Industrial Wireless Communication system substantially reduces cost and time for the installation and maintenance of the large number of cable, thus makes plants setup and reconfiguration easy and safe.

ICP DAS provides a great variety of wireless products with modular and universal solution specially designed for industrial harsh environment.

**Wireless and Mobile Total Solution**

**Software/SCADA/Utility**

- VxComm Utility
- NAPOPC
- InduSoft
- EZ Data Logger
- eLogger

**Programmable Automation Controllers**

- WP/LP-5000
- WP/LP-8000
- iPAC-8000
- ViewPAC-2xWx
- XPAC-8000
- IO Modules
- TPD-283
- TPD-430
- PCI/ISA Card

DSSS RF	2G/3G/4G	WLAN	ZigBee	GPS	IR
SST-2450	GTM-201 Series	Wi-Fi AP	ZigBee Converters	GPS Receivers	IR Modules
DSSS RF	2G/3G	WiFi	ZigBee	GPS	IR
M-7000 Series	G-4500 Series	I-7540D-WF	ZigBee I/O	Train	Air Conditioner
CNC Machine	GT-500 Series	M2M-711D	ZigBee Repeater	Public Transportation	Projector
Meters	Truck	Barcode Reader	Remote Controller	Cruise	Sound

# RS-485 Products



2.1	Communication Cards for PC/IPC	P 2-1
2.2	Communication Modules for PAC	P 2-2
2.3	Converter/Repeater/Hub/Splitter	P 2-3
2.4	Termination Resistor/DC Bias Voltage	P 2-5
2.5	RS-485 I/O Modules	P 2-6
2.6	RS-485 I/O Units	P 2-7



## 2.1 Communication Cards for PC/IPC

2

RS-485 Products



The VXC/VEX multi-Port serial card enables user to increase additional communication ports on PCs. It's the on-top-of-the-list choice while you are managing to connect lots of outer devices through your PC; every VXC/VEX card ensures you smooth communication in both time-critical applications and industrial fields. With simply a VXC card, it has never been that easy to integrate a PC with lots of devices, such as PLCs, machines, meters, controller devices, laboratory instruments, modems, card readers, serial printers, RFID readers, bar code readers, sensors.

### Selection Guide

Universal PCI → **VXC -** 1 X X

PCI Express → **VEX -**

PCI Express → **PCIe - S**

1: RS-232  
4: RS-422/485  
8: RS-232, RS-422/485

Number of Ports

Model Name		RS-232	RS-422/485	Isolation	ESD Protection	Max. Speed (bps)	FIFO Size (bytes)	Connector
	<b>VXC-112AU</b>	2	-	-	-	115.2 K	128	Male DB-9
	<b>VXC-112iAU</b>	2	-	2.5 kV	±4 kV	115.2 K	128	Male DB-9
	<b>VXC-142AU</b>	-	2	-	-	115.2 K	128	Male DB-9
	<b>VXC-142iAU</b>	-	2	2.5 kV	±4 kV	115.2 K	128	Male DB-9
	<b>VXC-182iU</b>	1	1	2.5 kV	±4 kV	115.2 K	128	Male DB-9
	<b>VXC-114U</b>	4	-	-	-	115.2 K	128	Female DB-37
	<b>VXC-114iAU</b>	4	-	2.5 kV	±4 kV	115.2 K	128	Female DB-37
	<b>VXC-144U</b>	-	4	-	-	115.2 K	128	Female DB-37
	<b>VXC-144iU</b>	-	4	2.5 kV	±4 kV	115.2 K	128	Female DB-37
	<b>VXC-118U</b> <span style="color: red; font-weight: bold;">NEW</span>	8	-	-	-	115.2 K	256	Female DB-62
	<b>VXC-148U</b> <span style="color: red; font-weight: bold;">NEW</span>	-	8	-	-	115.2 K	256	Female DB-62

Model Name		RS-232	RS-422/485	Isolation	ESD Protection	Max. Speed (bps)	FIFO Size (bytes)	Connector
	<b>VEX-112</b>	2	-	-	-	115.2 K	128	Male DB-9
	<b>VEX-112i</b>	2	-	2.5 kV	±4 kV	115.2 K	128	Male DB-9
	<b>VEX-142</b>	-	2	-	-	115.2 K	128	Male DB-9
	<b>VEX-142i</b>	-	2	2.5 kV	±4 kV	115.2 K	128	Male DB-9
	<b>VEX-114</b>	4	-	-	-	115.2 K	128	Female DB-37
	<b>VEX-114i</b>	4	-	2.5 kV	±4 kV	115.2 K	128	Female DB-37
	<b>VEX-144</b>	-	4	-	-	115.2 K	128	Female DB-37
	<b>VEX-144i</b>	-	4	2.5 kV	±4 kV	115.2 K	128	Female DB-37
	<b>PCIe-S118</b> <span style="color: red; font-weight: bold;">NEW</span>	8	-	-	-	921.6 K	256	Female DB-62
	<b>PCIe-S148</b> <span style="color: red; font-weight: bold;">NEW</span>	-	8	-	-	921.6 K	256	Female DB-62





## 2.2 Communication Modules for PAC



The communication modules offer the possibility to add several serial ports into a XPAC, WinPAC, ViewPAC and iPAC . Up to 4 ports, optionally isolated, RS-232, RS-422 or RS-485 ports.

2

RS-485 Products

Model Name	I-8112iW	I-8114W	I-8114iW	I-8142iW	I-8144iW
Pictures					
<b>Communication</b>					
Interface	RS-232	RS-232	RS-232	RS-422/485	RS-422/485
Port	2	4	4	2	4
Max. Speed (K bps)	115.2				
Controller Chip	16C950				
<b>System</b>					
Hot Swap	-	-	-	-	-
Isolation	2500 Vrms	-	2500 Vrms	2500 Vrms	
Power Consumption	1.5 W	1.25 W	1.75 W	1.5 W	1.75 W
Connector	Male D-Sub 9 x 2	Female D-Sub 37		Terminal Block	
Optional Accessories	CA-0915 CA-0910F	CA-9-3705 CA-9-3715D	CA-9-3705 CA-9-3715D	-	-



**CA-0910F**  
9-pin Female-Female D-sub cable, 1 M



**CA-0915**  
9-pin Male-Female D-sub cable, 1.5 M



**CA-9-3705**  
DB-37 Male (D-sub) to 4-Port DB-9 Male (D-sub) cable, 0.3 M, 90°



**CA-9-3715D**  
DB-37 Male (D-sub) to 4-Port DB-9 Male (D-sub) cable, 1.5 M, 180°



**DN-09-2F**  
I/O Connector Block with DIN-Rail Mounting and two 9-pin Male Header  
Includes : 2 x CA-0910F (9-pin Female-Female D-sub Cable 1.0 M)

## 2.3 Converter/Repeater/Hub/Splitter



U.S. Patent



### ICP DAS Self-Tuner ASIC Features:

- Multiple Baud Rate
- Multiple Data Format
- Automatic RS-485 Direction Control

### Self-Tuner Chip

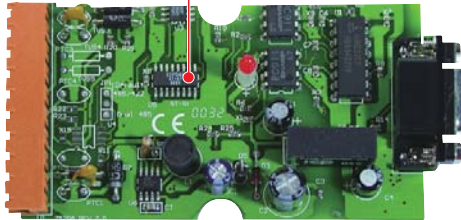

▲ I-7520

### "Self-Tuner"

A conventional RS-232 to RS-485 converter uses the DIP switch to select the baud rate and data format for the whole RS-485 network. All modules, devices and equipments in the network should be configured to the same baud rate and data format. Unfortunately most real world applications can't be implemented in such a simple way. The Self-Tuner is an innovative chip designed to solve this problem. Every converter contains a Self-Tuner chip. The chip automatically tunes the baud rate and data format to the whole network. Therefore the I-7520 can connect to modules, devices and equipments with different baud rates and data formats in a network.

Furthermore, the RS-485 is a 2-wire half-duplex network. To transmit and receive data via the twisted pair wire, a transmission direction control for the RS-485 is needed. In conventional designs, software has to switch a hardware handshaking signal such as RTS (Request To Send) to control the transmission direction. The Self-Tuner chip automatically detects and controls the direction of the transmission of the RS-485 network. So the application program does not have to care about the direction control.

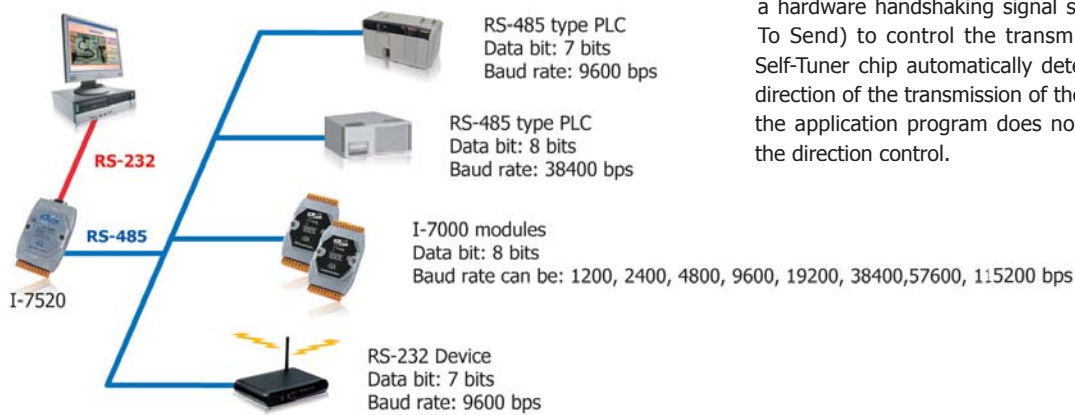

▲ I-7520U4

▲ I-7514U

### High Quality Isolated RS-485 Repeater/Hub/Splitter

The maximum effective distance of RS-485 without repeater is 1200 meters (4000 feet) at baud rates up to 9.6 Kbps and up to 32 (256) nodes can be connected. With the professional design, the repeater I-7510 solves the problem of signal weakening and extends the maximum effective distance by 1200m and connects 32 (256) nodes more. And it has optical isolation design for lightning and surge protection. If the RS-485 topology is too complex to make the communicating well, a RS-485 hub or splitter is recommended.

I-7520U4 and I-7514U are multichannel RS-485 repeater/hub/splitter. Each channel is independent and has optical isolation, short circuit and open circuit protection. Thus when one channel fails, it will not affect another channel of the hub. The features make it perfect to star type or mixed type topology in complex and large scale RS-485 network.

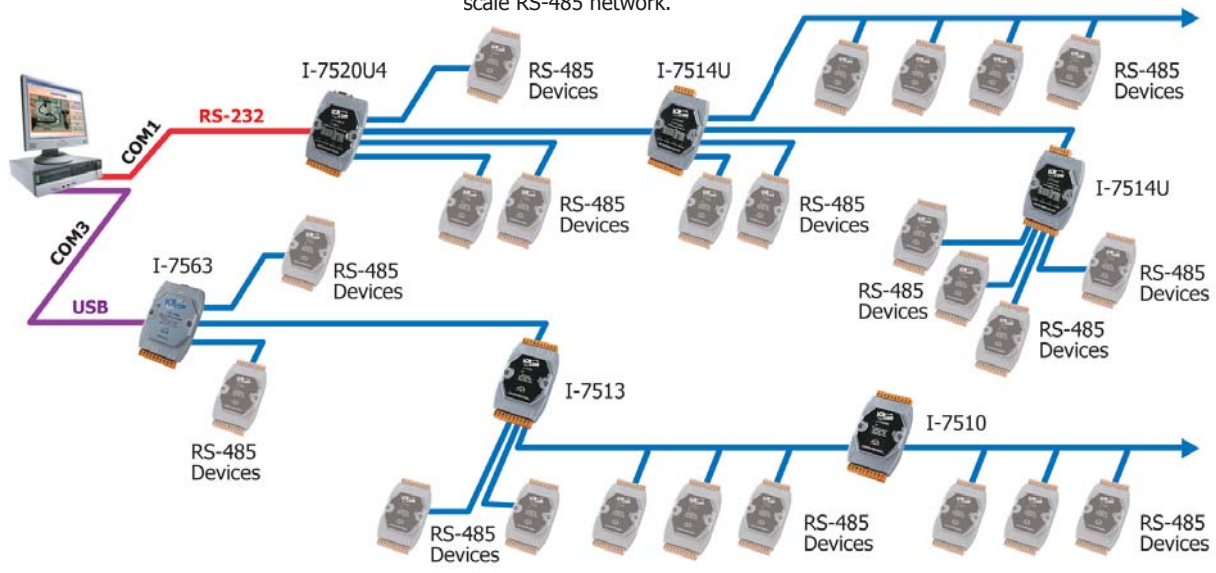

The following block diagram shows how I-7514U was designed as independent channel. Data coming from the master input will be transmitted to all four RS-485 slave channels. But data coming from the slave channels will be returned to the master input only. Thus reduces the possibility of interference between each RS-485 slave loop and makes the RS-485 networks more robust and reliable.

► I-7514U Block Diagram

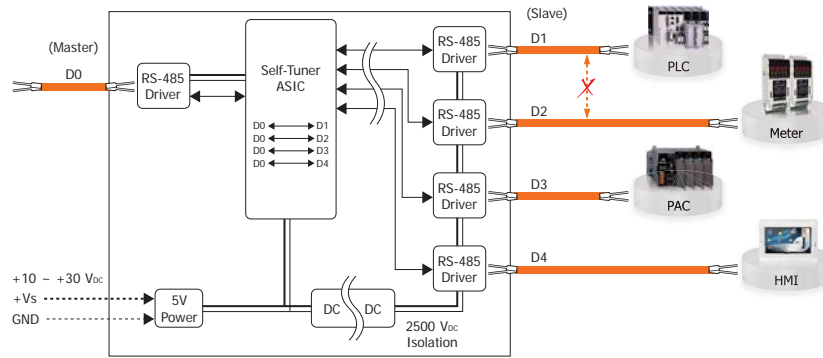

✓ RS-232/422/485 Converter/Repeater

Model Name	tM-7520U	I-7520	I-7520R	I-7520A	I-7520AR	I-7551	tM-7510U	I-7510	I-7510A	I-7510AR
Pictures										
Function	Converter					Repeater				
Interface	RS-232 to RS-485			RS-232 to RS-422/485		RS-232 to RS-232	RS-485	RS-485	RS-422/485	
Isolation	3000 VDC RS-232 side	3000 VDC RS-232 side	3000 VDC RS-485 side	3000 VDC RS-232 side	3000 VDC RS422/485 side	3000 VDC 3 ways	3000 VDC	3000 VDC		3000 VDC 3 ways
Operating Temperature	-25 ~ +75°C									

✓ USB to RS-232/422/485 Converter

Model Name	I-7560U	USB-2514	I-7561U	tM-7561
Pictures				
Function	Converter	Converter	Converter	Converter
Interface	USB to RS-232	USB to 4-Port RS-232	USB to RS-232/422/485	USB to RS-485
Isolation	-	-	3000 VDC	3000 VDC
Operating Temperature	-25 ~ +75°C			

✓ USB RS-232/485 to RS-485 Hub

Model Name	I-7563U	I-7513	I-7520U4	I-7514U
Pictures				
Function	3-Ch Hub/Splitter	3-Ch Hub/Splitter/Repeater	4-Ch Hub/Splitter	4-Ch Hub/Splitter/Repeater
Interface	USB to 3-Ch RS-485	RS-485 to 3-Ch RS-485	RS-232 to 4-Ch RS-485	RS-485 to 4-Ch RS-485
Isolation	3000 VDC	3000 VDC 3 ways	3000 VDC RS-232 side	3000 VDC Ch1-Ch4 side
Operating Temperature	-25 ~ +75°C			

More products refer to Industrial Communication & Networking Products Catalog

- Multi-Port Serial Cards
- Programmable Device Servers (Serial-to-Ethernet)
- Converters, Repeaters and Hubs
- Fieldbus Solutions
- Ethernet Switches

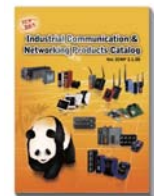

## 2.4. Termination Resistor/DC Bias Voltage

### The RS-485 Bias and Termination Resistors Module

#### tM-SG4



The tM-SG4 is an optional module that is used to improve the communication of RS-485 network. It provides switch selectable bias resistors on RS-485 network. It also has 15-step switch selectable termination resistor such that the user can select a proper termination resistor to be connected to the RS-485 network easily. If the RS-485 network is not over 100 meters, the termination resistors are not needed. Otherwise, it may be necessary to insert two termination resistors at both end of the RS-485 network. It is not easy to calculate the value of a termination resistor on the RS-485 network. The best way to do this is to use an oscilloscope to check the RS-485 signal directly. If the impedance match of RS-485 network is OK, the oscilloscope will show a very nice square wave. If these square wave signals are distorted, the user will need to insert two termination resistors at both end of the RS-485 network.

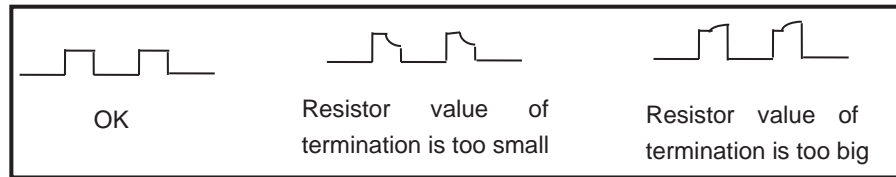

#### Features >>>

- Switch-selectable Bias Resistors
- 15-step Switch-selectable Termination Resistor
- LED Indicator for Power/Termination
- DIN-Rail Mountable
- Cost-effective
- Wide Operating Temperature Range: -25 ~ +75°C

#### Applications >>>

##### Termination Resistor

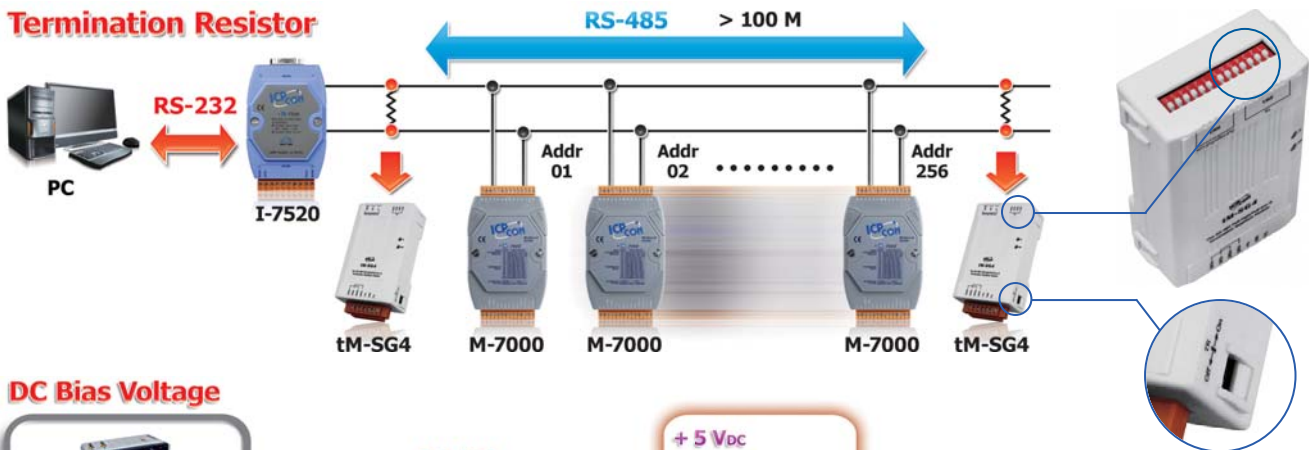

##### DC Bias Voltage







## 2.5 RS-485 I/O Modules

Although RS-485 is a very old technology, it is still a good choice to establish a cost-effective remote I/O system. Our RS-485 remote I/O module supports DCON protocol, Modbus RTU/ASCII protocol. According to different application, we have developed various RS-485 I/O modules, such as palm-size I-7000/M-7000 series (Ch 2.2) and tiny-size tM series (Ch2.3). The module has diversified I/O interface, such as overvoltage-protection analog input module, relay output, digital input/output, counter, timer.

The brief comparison is as the following table. Besides those regular RS-485 I/O modules, we can also provide some ODM modules.

Model Name	tM series	I-7000	M-7000
Pictures			
<b>Communication</b>			
Protocol	DCON, Modbus RTU, Modbus ASCII	DCON	DCON, Modbus RTU
Data Format	(N, 8, 1), (N, 8, 2), (O, 8, 1), (E, 8, 1)	(N,8,1)	
Max. Nodes	32	256	
Bias resistor	Yes, 10 K $\Omega$	No (Note1)	
Dual Watchdog	Yes, Module (2.3 second), Communication (Programmable)	Yes, Module (1.6 second), Communication (Programmable)	
<b>I/O</b>			
DIO Max. channel	8	16	
AIO	Resolution	12/14 bits	12/16 bits
	Max. channel	8 (tM-AD8)	20 (I-7017Z, M-7017Z)
	Individual Channel Configuration	-	Yes
<b>Display</b>			
Power and Communication LED	Yes	Yes	
I/O Status LED	-	Yes (for D version only)	
7-Segment LED	-	Yes (for D version only)	
<b>Mechanical</b>			
Dimensions (W x L x D)	52 mm x 98 mm x 27 mm	72 mm x 123 mm x 35 mm	

**Note1:** The RS-485 master is required to provide the bias. Otherwise, the tM-SG4 or SG-785 should be added to provide the bias. All ICP DAS controllers and converters provide the bias.

Furthermore, we also developed RU-87Pn, a series of RS-485 remote I/O unit for compact and modular I/O expansion. It comprises a CPU, a power module and a backplane with a number of I/O slots for flexible I/O configuration. With its patented technology, namely auto configuration and hot swap, it saves lots of labor on the set up and maintenance of the automation systems. Reliable 3-piece construction enables users to hot swap modules during operation, without rewiring. All I/O module data are backed up in the non-volatile memory of the RU-87Pn. After hot-swapping a module, all settings are automatically loaded to recover.



### Features

- Easy Maintenance and Diagnosis
- Easy Duplicate System
- Auto Configuration
- DCON Protocol
- Hot Swap



For more details of, refer to **PAC Product Catalog**



## 2.6 RS-485 I/O Units

### RS-485 I/O Expansion Unit

**RU-87P1**



**RU-87P4**



**RU-87P2**



**RU-87P8**



#### Features ▶▶▶

- One RS-485 Port for Multi-Drop Topology
- Switches to Configure Communication
- LED Indicators for Fault Detection
- 1/2/4/8 I/O Slots for I-87K Modules
- Hot Swap Allowed
- Auto Configuration
- DCON Protocol





#### Ordering Information ▶▶▶

<b>RU-87P1 CR</b>	1 slot I/O Expansion Unit (RoHS)
<b>RU-87P2 CR</b>	2 slots I/O Expansion Unit (RoHS)
<b>RU-87P4 CR</b>	4 slots I/O Expansion Unit (RoHS)
<b>RU-87P8 CR</b>	8 slots I/O Expansion Unit (RoHS)

Model Name	RU-87P1	RU-87P2	RU-87P4	RU-87P8
<b>Interface Type (RS-485)</b>				
Baud Rate	115200 bps maximum			
Distance	1.2 km (4000 ft) maximum			
Isolation	3000 Vdc			
ESD Protection	±4 K Contact Discharge and ±8 K Air Discharge			
Communication Protocol	DCON Protocol (ASCII Format)			
<b>Switch</b>				
Rotary Switch	x2, For RS-485 address			
DIP Switch	8-bit × 1, For auto configuration, check sum and baud rate			
<b>LED Indicators</b>				
Power	Yes			
System Ready	Yes			
Auto Configuration	Yes			
Slot Status	Yes			
<b>I/O Expansion Slots</b>				
Hot Swap	Yes			
Auto Configuration	Yes			
Support Module Type	High profile I-87K module only			
Slots Numbers	1	2	4	8
<b>Mechanical</b>				
Dimensions (W x L x H)	64 mm x 120 mm x 110 mm	95 mm x 132 mm x 111 mm	188 mm x 132 mm x 111 mm	312 mm x 132 mm x 111 mm
Installation	DIN-Rail or Wall Mounting			
<b>Environmental</b>				
Operating Temperature	-25 ~ +75°C			
Storage Temperature	-30 ~ +80°C			
Ambient Relative Humidity	10 ~ 90% RH (Non-condensing)			
<b>Power</b>				
Input Range	+10 ~ +30 VDC			
Reverse Polarity Protection	Yes			
<b>Isolation</b>				
Frame Ground	Yes			
Consumption	1 W	1 W	2 W	2.4 W
Power Board Driving	5 W	8 W	30 W	30 W

# Industrial Ethernet Products



<b>3.1</b>	<b>Overview</b>	<b>P 3-1</b>
<b>3.2</b>	<b>EtherCAT Products</b>	<b>P 3-2</b>
	<ul style="list-style-type: none"> <li>• Selection Guide ----- P 3-2</li> </ul>	
<b>3.3</b>	<b>EtherNet/IP Products</b>	<b>P 3-6</b>
	<ul style="list-style-type: none"> <li>• Selection Guide ----- P 3-6</li> <li>• EtherNet/IP Remote I/O Modules----- P 3-9</li> </ul>	
<b>3.4</b>	<b>PROFINET Products</b>	<b>P 3-10</b>
	<ul style="list-style-type: none"> <li>• Selection Guide ----- P 3-11</li> <li>• PROFINET Converters ----- P 3-12</li> <li>• PROFINET Gateways----- P 3-13</li> <li>• Analog Input &amp; Output Modules ----- P 3-15</li> <li>• Digital Input &amp; Output Modules ----- P 3-16</li> </ul>	
<b>3.5</b>	<b>Ethernet Device Servers</b>	<b>P 3-17</b>
	<ul style="list-style-type: none"> <li>• Selection Guide ----- P 3-18</li> </ul>	
<b>3.6</b>	<b>BACnet/IP Products</b>	<b>P 3-19</b>
	<ul style="list-style-type: none"> <li>• Selection Guide ----- P 3-19</li> <li>• Case Studies----- P 3-20</li> <li>• BACnet Gateways----- P 3-21</li> <li>• BACnet/IP I/O Modules ----- P 3-22</li> </ul>	
<b>3.7</b>	<b>Industrial Ethernet/Fiber Switches</b>	<b>P 3-23</b>
<b>3.8</b>	<b>Ethernet I/O Modules (Modbus TCP/UDP Slave)</b>	<b>P 3-28</b>
	<ul style="list-style-type: none"> <li>• Selection Guide ----- P 3-31</li> </ul>	
<b>3.9</b>	<b>MQTT I/O Module</b>	<b>P 3-33</b>
	<ul style="list-style-type: none"> <li>• Selection Guide ----- P 3-33</li> </ul>	
<b>3.10</b>	<b>Wi-Fi Products</b>	<b>P 3-34</b>
	<ul style="list-style-type: none"> <li>• Selection Guide ----- P 3-34</li> <li>• Wi-Fi Converter ----- P 3-35</li> <li>• Wi-Fi Bridge ----- P 3-35</li> <li>• WLAN Remote Maintenance Device ----- P 3-36</li> <li>• Wi-Fi Gateway----- P 3-36</li> <li>• Wi-Fi I/O Modules ----- P 3-37</li> </ul>	

### 3.1 Overview

Industrial Ethernet is a kind of technology, which uses the Ethernet family of computer network technologies in an industrial environment, for automation and process control. By using standard Ethernet interface, the automation units from different manufacturers can be easy to interconnect with each other throughout an application system. Industrial Ethernet takes advantage of the relatively larger marketplace because the comprehensive usage of the Ethernet interconnections could reduce cost and improve performance of communications between industrial controllers.

ICP DAS foresees the market trend and have announced several Industrial Ethernet products. In addition to the Modbus TCP series, ICP DAS also offers different product lines of the EtherCAT, EtherNet/IP, PROFINET and BACnet/IP application protocols. Through them, to construct a multi-function automation system can be more flexible and be easy to integrate the computers and the Industrial Ethernet products from different manufactures.

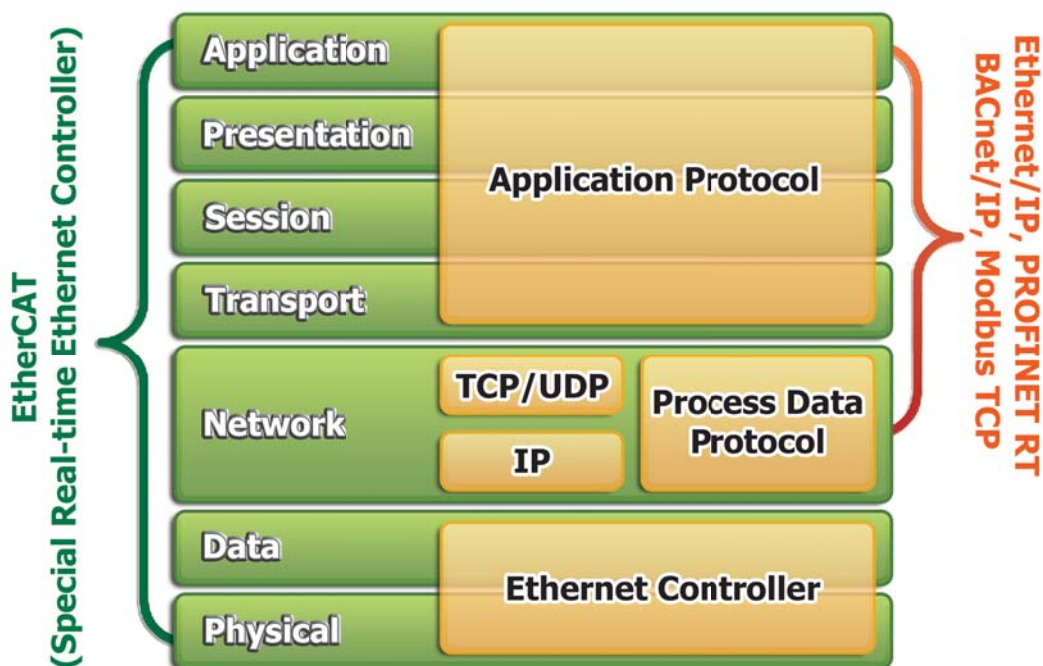

Protocol	Modbus TCP	EtherCAT	EtherNet/IP	PROFINET RT	BACnet/IP
Trademark					
Organization	Modbus	ETG	ODVA	PI	SSPC
Special Hardware	No	Yes	No	No	No
Ethernet Switch	Yes	No	Yes	Yes	Yes
Cycle Time	Normal	Fast	Normal	Good	Normal
Topology Flexibility	Normal	Good	Normal	Normal	Normal
Data Integration	Easy	Normal	Easy	Easy	Easy

## 3.2 EtherCAT Products

EtherCAT (Ethernet for Control Automation Technology) is an open, high-performance fieldbus system that makes Ethernet technologies available at the I/O level. EtherCAT provides flexible wiring, fast communication and many other nice features. It needs a master to control many slaves. ICPDAS provides PC master cards, PEC-800 and PEC-801, for users to build their applications including motion control. These cards can offer multi-axis motion and I/O control functions by their own built-in CPU. In this way, the CPU loading of PC can be reduced dramatically. In the mean while, ICPDAS also provides many I/O slave modules for users to choose from. Since EtherCAT technology is an industrial standard, those modules can work together in a system with 3rd-party EtherCAT slaves as well.

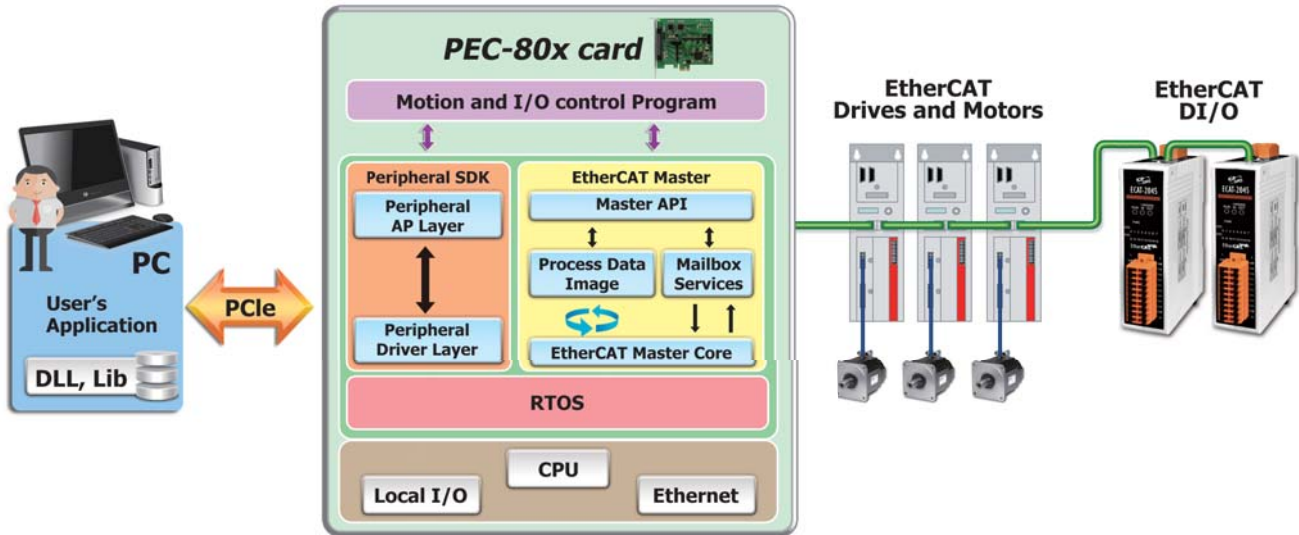

- **Versatile Motion Functions**

P-to-P, Line, circle, 3D-arc, helix and other motion functions are provided.

- **Networking Standards**

The PEC-80x card is based on EtherCAT and CiA402 standards for precise multi-axis control. Third-party EtherCAT I/O slaves are also supported.

- **Programming API**

Fast application implementation is enabled by using motion API provided by ICP DAS.

### Applications:

- Packaging
- Material handling
- Textile
- Printing and automotive applications
- Machine tools
- Robotics
- Industrial automation

- **Flexible and Easy Wiring**

EtherCAT is a network technology which makes the system wiring is easy and cost effective. Various coupler and junction slaves are provided to flexible wiring and less cabling.



### Selection Guide

EtherCAT Solution Products of Remote Motion Solutions		
<b>Master Cards</b>	PEC-800 PEC-801	PCIe EtherCAT Master Card
<b>Motion Control Modules</b>	ECAT-2092(T) ECAT-2093	EtherCAT Encoder Modules
	ECAT-2091S ECAT-2094S ECAT-2098S	EtherCAT Stepping Motor Driving Modules
	ECAT-2015 ECAT-2017 ECAT-2018	EtherCAT Analog Input Modules
<b>I/O Modules</b>	ECAT-2024 ECAT-2028	EtherCAT Analog Output Modules
	ECAT-204x ECAT-205x ECAT-206x	EtherCAT Digital Input/Output Modules
	ECAT-2511-A ECAT-2511-B	EtherCAT to Single-mode Fiber Converters
<b>Junction Slave Modules</b>	ECAT-2512 ECAT-2513	EtherCAT Junction Slave Modules



### EtherCAT Master Card



Model Name	PEC-800	PEC-801
Pictures		
<b>Communication Interface</b>		
Connector	1x RJ45	
Speed	100 Mbit/s	
Protocol	EtherCAT Master	
No. of Slave Node	Max. 32	
No. of Motion Control	Max. 16-Axis Synchronously	
<b>Digital Output</b>		
Channels	12	13
Output type	Sink(open collector)	
max load Current	100mA /ch	
<b>Digital Input</b>		
Channels	12	13
type	Wet (Sink/Source)	
<b>Encoder</b>		
Axis	-	2
Type	-	A/B Phase, CW/CCW, Pulse/Dir.
Speed, Resolution	1 MHz, 32-bit	
Compare Trigger Output	2-ch	



### Encoder Module



Model Name	Axis	Type	Operating Voltage	Speed	Counter	Compare Trigger Out	Hardware Latch	Hardware Reset
<b>ECAT-2092</b>	2	1. A/B Phase	5/24 V (Jumper Select)	6 MHz (5V)	32-bit	-	Yes	Yes
<b>ECAT-2092T</b>	2	2. CW/CCW				2 (Open Collector)	Yes	Yes
<b>ECAT-2093</b>	3	3. Pulse/Dir.				-	-	-



### Stepping Motor Driving Module



Model Name	Driver					Encoder				
	Axis	Type	Resolution	Output Current	Voltage Range	Axis	Type	Operating Voltage	Resolution	Speed
<b>ECAT-2091S</b>	1	2-phase stepper motor	200 x 256	2A per axis	5 ~ 40 V	1	A/B Phase	5 V	32-bit	1 MHz
<b>ECAT-2094S</b>	4					-	-	-	-	
<b>ECAT-2098S</b>	8					-	-	-	-	



### Analog Input Module



Model Name	Channel	Input Range	Resolution	Accuracy	Output Capability
<b>ECAT-2015</b>	7	Pt100, Pt1000, Ni120, Cu50, Cu100, Cu1000	16-bit	0.1% of FSR	10 Hz (Total)
<b>ECAT-2017</b>	8/16	0~10V, ±10 V, ±5 V, ±2.5 V, 0~ 20 mA, ±20 mA or 4~20mA (Software selectable)	12-bit	0.2% of FSR	1k Hz per channel
<b>ECAT-2018</b>	8	J, K, T, E, R, S, B, N, C, L, M, LDIN43710 (Software selectable)	16-bit	0.1% of FSR	10 Hz (Total)



## Analog Output Module



Model Name	Channel	Output Range	Resolution	Accuracy	Output Capability
<b>ECAT-2024</b>	4	$\pm 10V, \pm 5V,$	12-bit	$\pm 2$ LSB	10V @ 5mA
<b>ECAT-2028</b>	8	0~10V, 0 ~ 5V			



## Digital I/O Module



Model Name	Digital Input		Digital Output		
	Channels	Type	Channels	Type	Max. Load
<b>ECAT-2057</b>	-	-	16	Open Collector (Sink)	100 mA
<b>ECAT-2057-PNP</b>	-	-	16	Open Emitter (Source)	100 mA
<b>ECAT-2057-8P8N</b>	-	-	8	Open Collector (Sink)	100 mA
			8	Open Emitter (Source)	100 mA
<b>ECAT-2045</b>	-	-	16	Open Collector (Sink)	700 mA
<b>ECAT-2045-32</b>	-	-	32	Open Collector (Sink)	600 mA
<b>ECAT-2051</b>	16	Dry (Source), Wet (Sink/Source)	-	-	-
<b>ECAT-2051-32</b>	32	Dry (Source), Wet (Sink/Source)	-	-	-
<b>ECAT-2050</b>	14	Dry (Source), Wet (Sink/Source)	4	Open Collector/ Emitter by Jumper Selectable	100 mA
<b>ECAT-2052</b>	8	Wet (Sink/Source)	8	Open Emitter (Source)	100 mA
<b>ECAT-2052-NPN</b>				Open Collector (Sink)	
<b>ECAT-2053</b>	16	Wet (Sink/Source)	-	-	-
<b>ECAT-2055</b>	8	Dry (Source), Wet (Sink/Source)	8	Open Collector (Sink)	700 mA
<b>ECAT-2055-32</b>	16	Dry (Source), Wet (Sink/Source)	16	Open Collector (Sink)	700 mA
<b>ECAT-2060</b>	6	Dry (Source), Wet (Sink/Source)	6	Relay, Form A (SPST-NO)	5A
<b>ECAT-2060-20</b>	10	Dry (Source), Wet (Sink/Source)	10	Relay, Form A (SPST-NO)	5A
<b>ECAT-2061</b>	-	-	16	Relay, Form A (SPST-NO)	5A

NEW

## EtherCAT Media Fiber Converter

### ECAT-2511-A ECAT-2511-B



The ECAT-2511-A and ECAT-2511-B are EtherCAT to single-mode fiber optic converter. They are designed not only to convert EtherCAT signals to optical signals on a fiber optic cable, to reshape the EtherCAT signal to compensate for distortion, but to isolate the bus error due to the wire short or disturbance. With the advantage of fiber optic, the ECAT-2511-A and ECAT-2511-B enable secure data transmission via fiber optic transmission, and help the EtherCAT network to prevent the noise from EMS/RFI interference.

- EtherCAT Type: RJ45, 100 Base-TX
- Fiber Type: SC, Single mode, 100 Base-FX
- Fiber Cable: 8.3/125, 8.7/125, 9/125 or 10/125  $\mu$ m
- Max. transmission distance up to 25 km
- Fiber Wavelength:
  - Tx: 1310 nm, Rx: 1550 nm for ECAT-2511-A
  - Tx: 1550 nm, Rx: 1310 nm for ECAT-2511-B

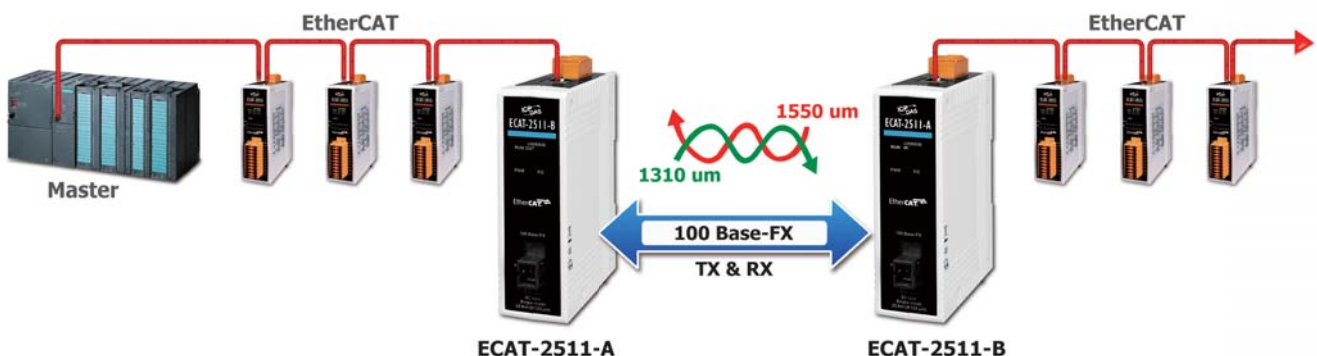



NEW

### EtherCAT Junction Slave Modules

**ECAT-2512**  
**ECAT-2513**

ECAT-2512 and ECAT-2513 are 1-to-2 port and 1-to-3 port EtherCAT junction slaves. They are designed for realizing flexible wiring by daisy chain and branch.

Model Number	<b>ECAT-2512</b> 	<b>ECAT-2513</b> 
No. of Port	3 x RJ45 (1 in, 2 out)	4 x RJ45 (1 in, 3 out)
No. of Node	1	2

**Benefit 1: Translate Daisy-chain to Branch Topology**

EtherCAT junction slaves can realize branch topology. They makes the cabling easier than daisy-chain topology.

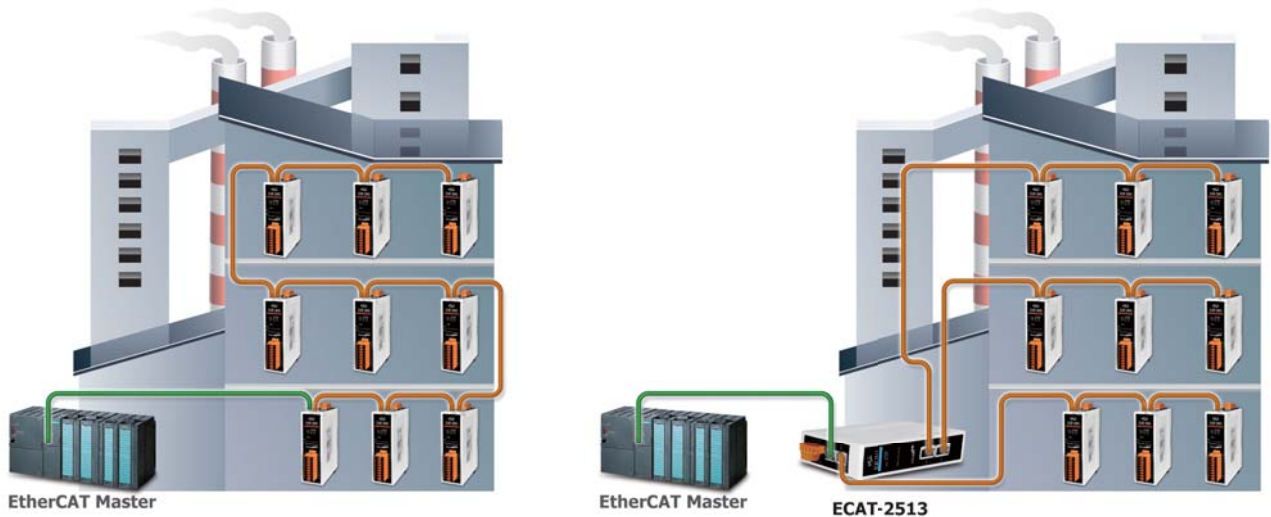

**Benefit 2: Improving the Debugging Efficiency**

If a slave device is not working or the cable is disconnected, the following slave devices on the same network all not communicate with the master controller.

With EtherCAT junction slaves, all slave devices can be wired as separated sections. If one slave device is failed, only the slave devices on the same section will be influenced. The EtherCAT junction slave keeps the slave devices on another section communicate with the master controller. Debugging can be made separately, thus improving the debugging efficiency.

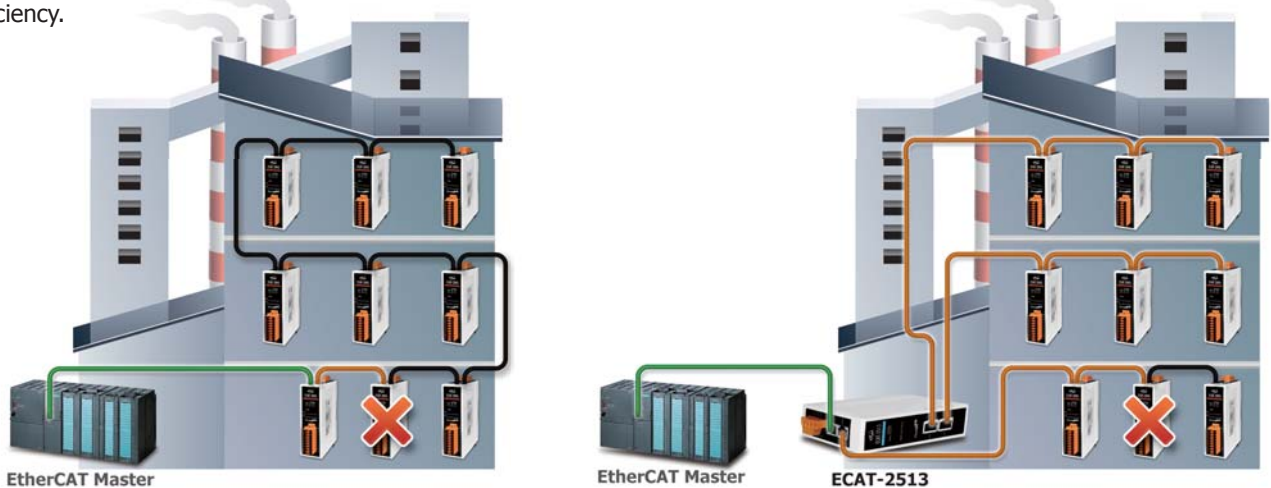



### 3.3 EtherNet/IP Products

EtherNet/IP is one of the open network standards, like DeviceNet and ControlNet. It is an industrial application layer protocol for industrial automation applications. EtherNet/IP uses all of the protocols of traditional Ethernet including the Transport Control Protocol (TCP), the Internet Protocol (IP) and the media access and signaling technologies. Building on standard Ethernet technologies means that EtherNet/IP will work transparently with all the standard Ethernet devices found today. EtherNet/IP application layer is based on the "Common Industrial Protocol" (CIP) which is used in both DeviceNet and ControlNet. This standard organizes networked devices as a collection of objects. It defines the access, behavior and extensions, which allow vastly different devices to be accessed using a common protocol. Based on these protocols, EtherNet/IP provides a seam-less integrated system from the Industrial floor to the enterprise network.

EtherNet/IP uses all the transport and control protocols of standard Ethernet including the Transport Control Protocol (TCP), the User Datagram Protocol (UDP), the Internet Protocol (IP) and the media access and signaling technologies found in off-the-shelf Ethernet technology. Building on these standard communication technologies means that EtherNet/IP works transparently with all the standard Ethernet devices found in today's marketplace.

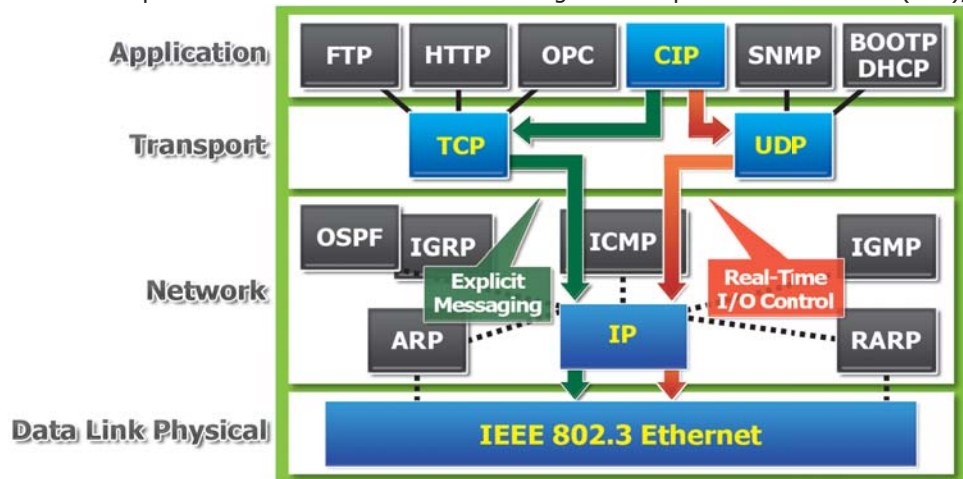

#### Features:

- Offer Producer-consumer service that enable users to control, configure and collect data.
- Uses exiting IEEE standards for Ethernet physical layer and data link layer.
- Provide flexible installation options leveraging commercially available industrial infrastructure products, including copper, fiber, fiber ring and wireless solutions.
- Provide robust physical layer options for industrial environments and includes the use of sealed RJ45 and M12 D-coding connector.
- Compatible with general communication standards, including OPC, TCP/IP, HTTP, FTP, SNMP, DHCP.
- Use TCP port number 44818 for explicit messaging and UDP port number 2222 for implicit messaging.
- Transfer of basic I/O data via UDP-based implicit messaging.
- Uploading and downloading of parameters, programs and recipes via TCP.
- Polled, cyclic and change-of-state monitoring via UDP.
- One-to-one (unicast), one-to-many (multicast), and one-to-all (broadcast) communication via TCP



#### Selection Guide

Model Name		Description
<b>EtherNet/IP Gateways</b>	GW-7472	Ethernet/IP Adapter to Modbus TCP/RTU Master Gateway
	GW-7473	Modbus TCP/RTU Slave to EtherNet/IP Scanner Gateway
<b>EtherNet/IP I/O Modules</b>	EIP-2017	EtherNet/IP I/O Module with Isolated 8-Ch Voltage/Current Inputs
	EIP-2019	Ethernet/IP I/O Module with 8-Ch Thermocouple Inputs
	EIP-2024	Ethernet/IP I/O Module with 4-Ch Voltage/Current Outputs
	EIP-2042	Ethernet/IP I/O Module with 16-Ch DO
	EIP-2051	Ethernet/IP I/O Module with 16-Ch DI
	EIP-2055	Ethernet/IP I/O Module with 8-Ch DI, 8-Ch DO
	EIP-2060	Ethernet/IP I/O Module with 6-Ch DI, 6-Ch Relay

NEW

## EtherNet/IP Adapter to Modbus TCP/RTU Master Gateway

### GW-7472



The GW-7472 (EtherNet/IP adapter to Modbus TCP/RTU Master Gateway) is helpful for data-exchanging between the Modbus RTU Network, Modbus TCP Network, and the EtherNet/IP Network. It reads the register data from the Modbus RTU slaves as well as Modbus TCP servers and publishes these data to the input register data of the EtherNet/IP scanner. The output data transmitted by the EtherNet/IP scanner are updated to the register data of Modbus TCP/RTU slaves via the GW-7472.

#### General Features >>>

- 10/100 Base-TX Ethernet, RJ-45 x1
- Redundant power inputs: PoE (IEEE 802.3af, Class 1) and DC jack
- Automatically RS-485 direction control
- Tiny form-factor and low power consumption

#### EtherNet/IP Features >>>

- Ethernet Protocol: EtherNet/IP adapter
- Maximum number of connections for Explicit Messages: 6
- Maximum number of connections for Implicit Messages: 1
- EtherNet/IP Input/Output command data size: maximum 500 bytes
- Supported I/O connection methods:
  - ★ Transport and trigger: Exclusive-Owner, Cyclic
  - ★ Originator to Target Type: POINT2POINT
  - ★ Target to Originator Type: POINT2POINT, MULTICAST

#### Modbus Features >>>

- Maximum support 8 Modbus commands for each one Modbus TCP server
- Modbus Input/Output command data size: maximum 500 bytes
- Supported Modbus Function Code 01, 02, 03, 04, 05, 06, 15, and 16
- Modbus Protocol: Modbus TCP/RTU master protocols
- Maximum support 30 Modbus RTU commands
- Maximum support 10 Modbus TCP servers

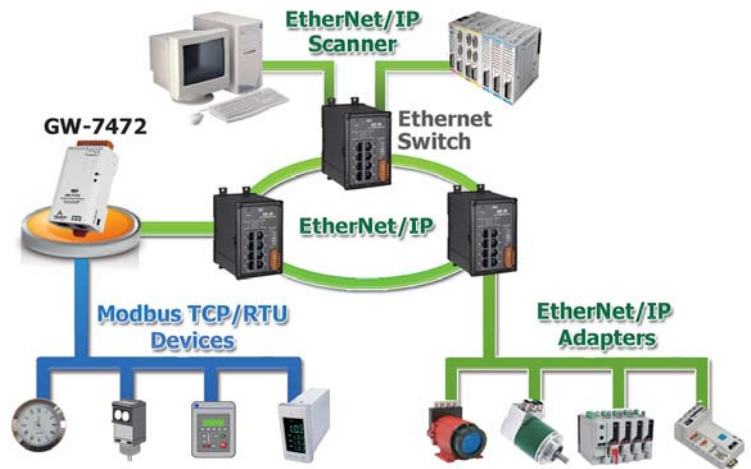

NEW

## Modbus TCP/RTU Slave to EtherNet/IP Scanner Gateway

### GW-7473



The GW-7473 (Modbus TCP/RTU Slave to EtherNet/IP Scanner Gateway) is helpful for data-exchanging between Modbus Master and EtherNet/IP adapter. It reads the register data from the EtherNet/IP adapter and publishes these data to the input register data of the Modbus TCP client as well as Modbus RTU Master. The output data transmitted by the Modbus TCP/RTU Master are updated to the register data of EtherNet/IP adapter.

#### General Features >>>

- 10/100 Base-TX Ethernet, RJ-45 x1
- Redundant power inputs: PoE (IEEE 802.3af, Class 1) and DC jack
- Automatically RS-485 direction control
- Tiny form-factor and low power consumption

#### EtherNet/IP Features >>>

- Supported Objects according to CIP Standard
  - ★ Assembly Object
  - ★ Connection Manager Object
  - ★ Ethernet Link Object
  - ★ Message Router Object
  - ★ TCP/IP Interface Object
- Ethernet Protocol: EtherNet/IP Scanner
  - ★ Scanner Class Functionality
  - ★ Class 1 (connected) I/O Server and Client

#### Modbus Features >>>

- Modbus Protocol: Modbus TCP Server/RTU Slave protocols
- Supported Modbus Function Code 01, 02, 03, 04, 05, 06, 15, and 16
- Maximum support 15 Modbus TCP clients

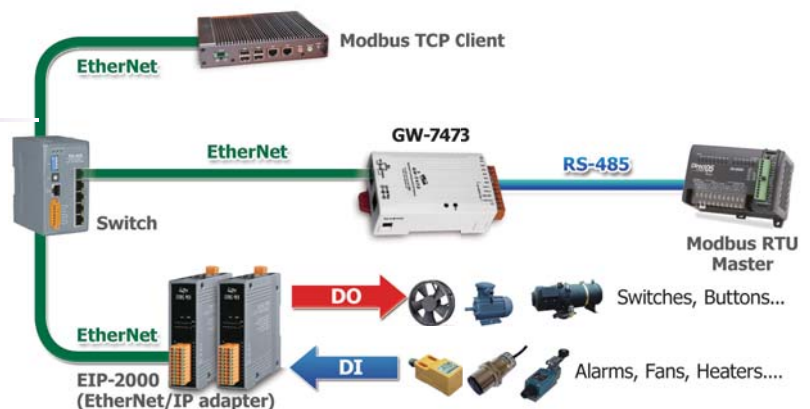

## Application

The application of sewage treatment plant is getting more and more important. The sewage treatment plant needs to reconstruct the control system. We provide a GW-7472 solution with AB PLC (Allen-Bradley ControlLogix 5563 via 1756-ENBT). Users can convert the data between EtherNet/IP and Modbus Protocol.

In the control room, GW-7472 gets the motors, meters and sensors information and publishes these data to PLC. PLC can also transmit data to the Modbus device via GW-7472.

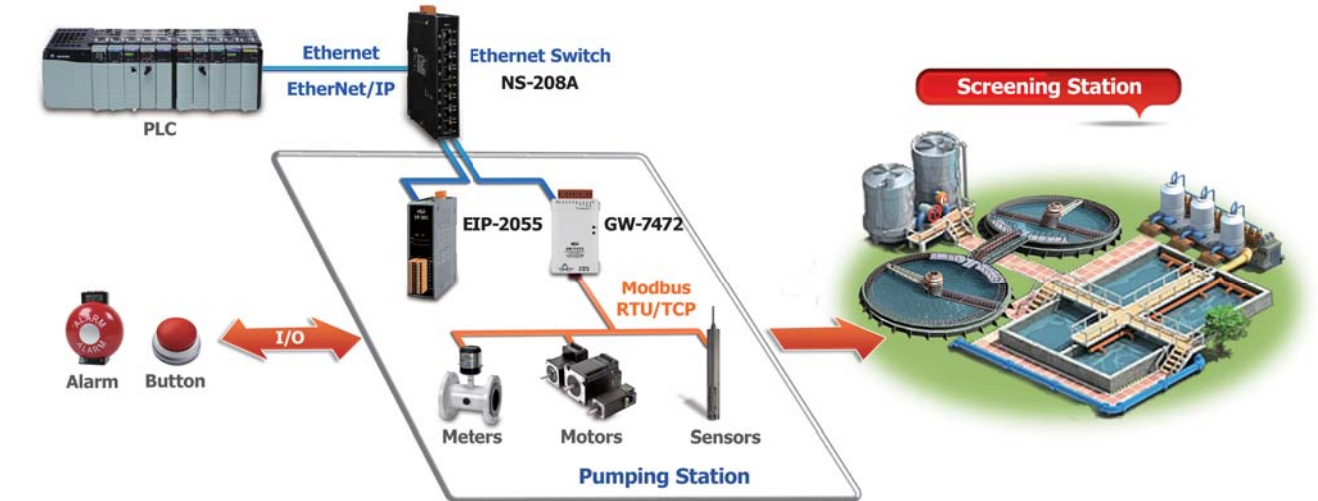

In the screw factory, the screw and the other elements need to be counted at the same time. We provide a detective solution with GW-7473 and EIP-2000 module. Users do not need the PLC to be a scanner.

EIP-2000 module receives the I/O status and publishes these data to GW-7473. Users can read data by PC via Modbus RTU or Modbus TCP.

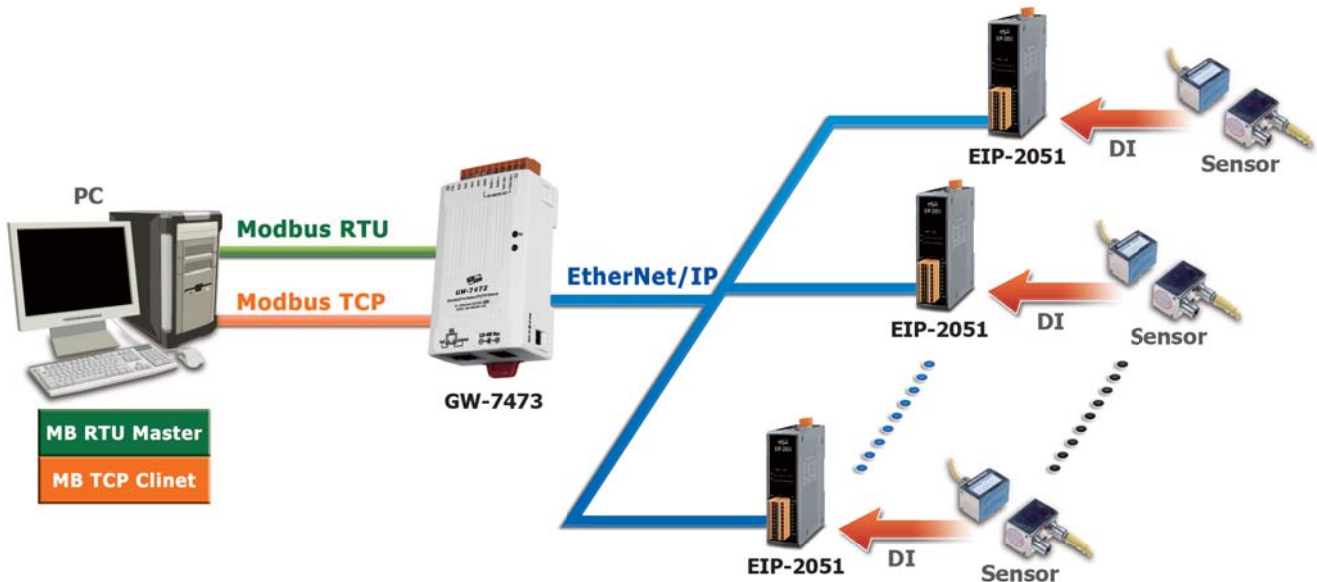



## EtherNet/IP Remote I/O Modules

Analog Input & Output Module			
Model Name	EIP-2017	EIP-2019	
	8-ch(DIFF.)/16-ch(S.E.) analog inputs module	8-Ch Thermocouple Input Module	
Pictures			
Analog Input			
Channels	Differential	8 (Differential)	8 (Differential)
	Single-Ended	16	-
Sensor Type	-	Thermocouple (J, K, T, E, R, S, B, N, C)	
Voltage Input Range	±15 mV, ±50 mV, ±100 mV, ±500 mV, ±1 V, ±2.5 V, ±5 mV, ±10 mV	±15 mV, ±50 mV, ±100 mV, ±500 mV, ±1 V, ±2.5 V, ±5 V, ±10 V	
Current Input Range	±20 mA, 0~+20 mA, +4 mA~+20 mA (Jumper Selectable)	±20 mA, 0~+20 mA, +4 mA~+20 mA (Required External 125Ω Resistor)	
Resolution	16-bit	16-bit	
Sampling Rate	10 Hz	10 Hz	
Accuracy	±0.1% of FSR	±0.1% of FSR	
Overvoltage Protection	240 Vrms	240 Vrms	
Input Impedance	400 kΩ	400 kΩ	
EDS Protection	4 kV Contact for each channel	4 kV Contact for each channel	
Intra-Module Isolation	3000 VDC	3000 VDC	

Module	DI		DO		AI		AO	
EIP-2026	Channel	Type	Channel	Type	Channel	Type	Channel	Type
	2	Dry, Source	3	Open Collector Sink, 700mA/Channel	5	Voltage, Current (Jumper), Thermocouple	2	Voltage, Current (Jumper)

Digital Input & Output Module				
Model Name	EIP-2042	EIP-2051	EIP-2055	EIP-2060
	16-Ch DO Module	16-Ch DI Module	8-Ch DI, 8-Ch DO Module	6-Ch DI, 6-Ch Relay Module
Pictures				
Digital Input				
Channels	-	16	8	6
Contact	-	Dry + Wet	Dry + Wet	Dry + Wet
Sink/Source (NPN/PNP)	-	Sink/Source	Sink/Source	Sink/Source
Wet Contact	On Voltage Level	+10 ~ 50 VDC	+10 ~ 50 VDC	+10 ~ 50 VDC
	Off Voltage Level	+4 VDC Max.	+4 VDC Max.	+4 VDC Max.
Dry Contact	On Voltage Level	Close to GND	Close to GND	Close to GND
	Off Voltage Level	Open	Open	Open
Input Impedance	-	10 kΩ, 0.5W	10 kΩ, 0.5W	10 kΩ, 0.5W
Digital Output				
Channels	16	-	8	6
Type	Open Collector	-	Open Collector	Power Relay
Sink/Source (NPN/PNP)	Sink (NPN)	-	Sink (NPN)	Form A
Load Voltage	+3.5 ~ +50 VDC	-	+3.5 ~ +50 VDC	30 VDC/125 VAC
Max. Load Current	700 mA/Channel	-	700 mA/Channel	5 A @ 30 VDC, 5 A @ 125 VAC
Overvoltage Protection	60 VDC	-	60 VDC	-
Overload Protection	Yes	-	Yes	-
Power-on Value	Yes	-	Yes	Yes
Safe Value	Yes	-	Yes	Yes

### 3.4 PROFINET Products

#### Introduction:

PROFINET is the Ethernet based standard for real-time automation that specified and published by PI (PROFIBUS & PROFINET International – <http://www.profibus.com>). PROFINET uses Ethernet standard as well as TCP, UDP and IP as protocols for communication, configuration and diagnosis in the network. Therefore, it is easy to be integrated to existing fieldbus systems, like PROFIBUS DP, PROFIBUS PA, Interbus, DeviceNet and other technologies to an open Ethernet based network without changes to existing field devices.

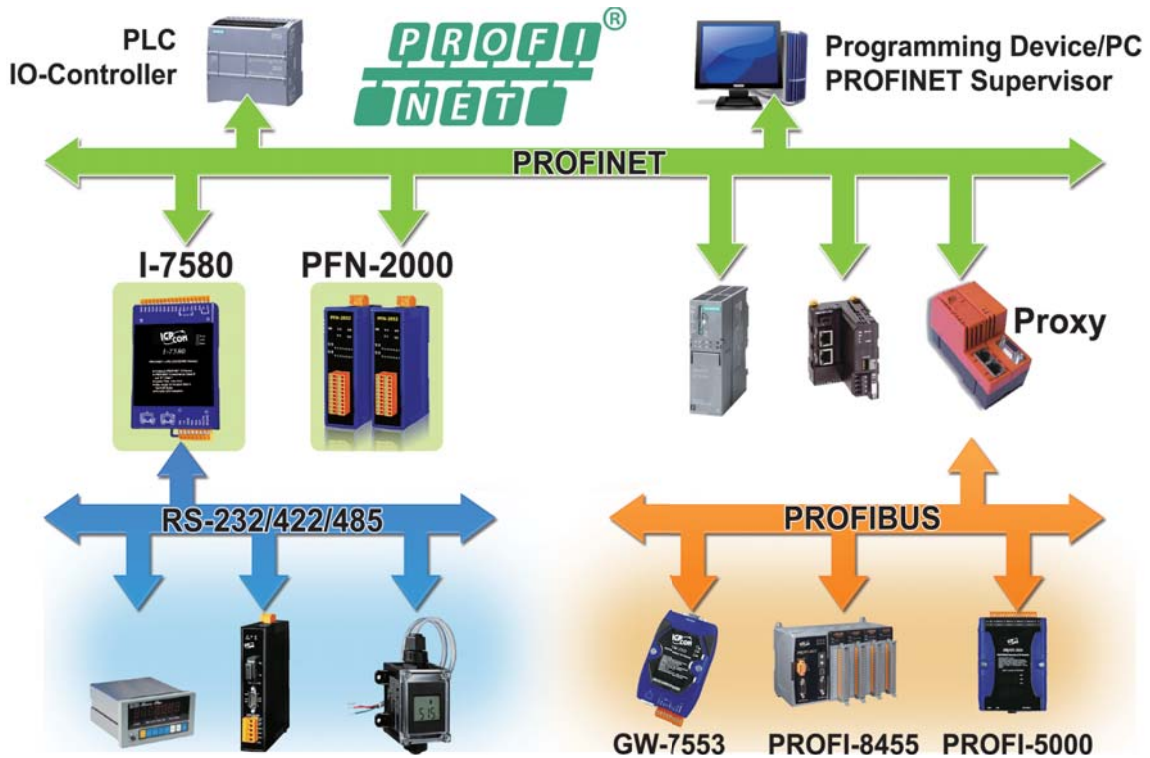

PROFINET contains 2 different solutions. They are PROFINET IO and PROFINET CBA (Component Based Automation).

PROFINET CBA is a communication solution for autonomously acting partial units of machines or plants. PROFINET IO is used for communication with decentral periphery like IOs, drives, etc. PROFINET products of ICP DAS are PROFINET IO devices.

The PROFINET standard defines three different performance levels which cover the various requirements from different applications.

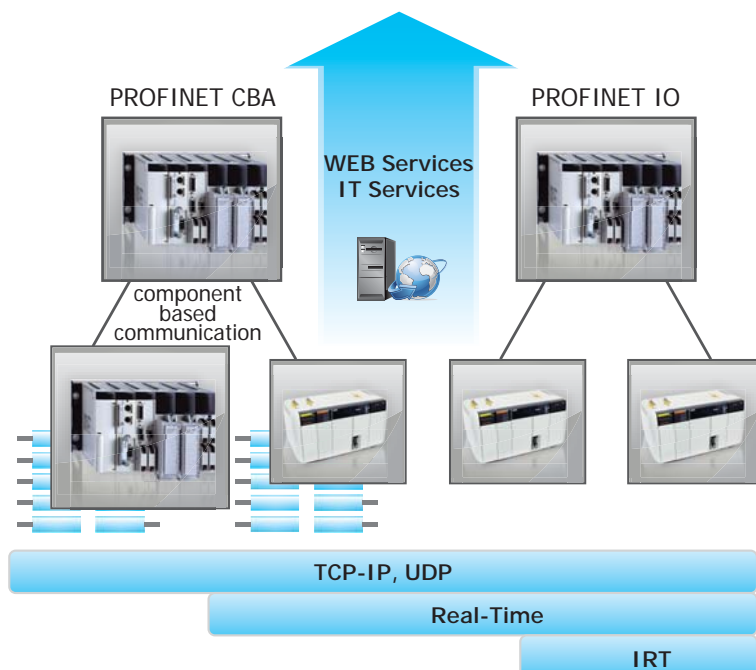

### PROFINET NRT (Non Real Time)

It uses standard protocols as UDP/IP. With response time approx. 100 ms PROFINET NRT targets for applications in process automation.

### PROFINET RT (Real Time)

For applications with higher requirements on cycle time like factory automation, it directly uses the Ethernet protocol to exchange I/O data, while diagnosis and configuration uses standard UDP/IP. PROFINET RT enables applications With response time approx. > 10 ms.

### PROFINET IRT (Isochronous Real Time)

The highest requirements come from the control of complex industrial drive systems, like packaging machines or robotics. With applications with cycle time < 1 ms and jitter < 1 μs are possible. The PFN-2000 series provides various I/O modules that meet PROFINET RT for process automation, factory automation.

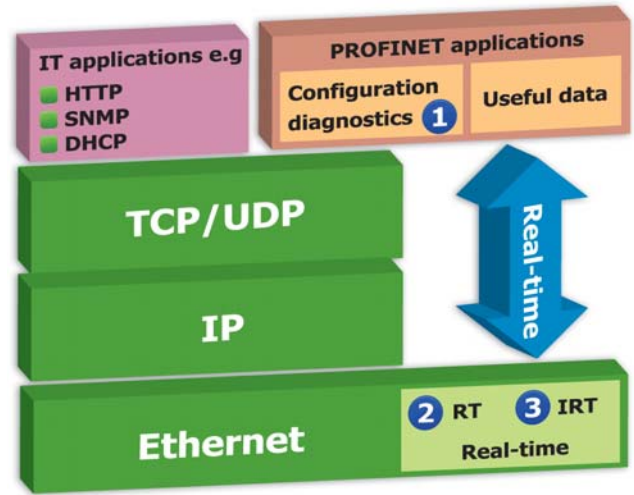

#### 1 TCP/IP

- Device parameterization and configuring
- Reading of diagnostic data
- Negotiating the useful data channel

#### 2 Real-time RT

- Effective cyclic transmission of useful data
- Event-driven messages/alarms

#### 3 Isochronous real-time IRT

- Useful data transfer in isochronous mode
- Hardware support through ERTEC
- Jitter < 1 μs

## Features:

- Transfer protocol: PROFINET IO
- Supported Ethernet services: ICMP, IGMP, ARP, DHCP, TELNET, TFTP, SNMP, VLAN Priority Tagging
- Supported PROFINET services: RTC, RTA, CL-RPC, DCP, LLDP, I&M
- PROFINET Conformance Class B and RT Class 1
- Cyclic Time: 1 ms (min)
- Generic GSDML File Provided
- Automatic MDI / MDI-X Crossover for Plug-and-play



### Selection Guide

Model Name		Description
<b>PROFINET Converter</b>	I-7580	PROFINET to RS-232/422/485 Converter
<b>PROFINET Gateway</b>	GW-7662	PROFINET to Modbus RTU/ASCII Gateway
	GW-7663	PROFINET to Modbus TCP Gateway
<b>PROFINET I/O Module</b>	PFN-2019	PROFINET I/O Module with 8-Ch universal AI
	PFN-2024	PROFINET I/O Module with 4-Ch AO
	PFN-2042	PROFINET I/O Module with 16-Ch DO
	PFN-2051	PROFINET I/O Module with 16-Ch DI
	PFN-2052	PROFINET I/O Module with 8-Ch DI
	PFN-2053	PROFINET I/O Module with 16-Ch DI
	PFN-2055	PROFINET I/O Module with 8-Ch DI, 8-Ch DO
	PFN-2060	PROFINET I/O Module with 6-Ch DI, 6-Ch Relay



## PROFINET Converters

NEW

### PROFINET to RS-232/422/485 Converter

#### I-7580



The I-7580 is specially designed for PROFINET IO device. It offers RS-232, RS-422, and RS-485 three kinds of communication way. With the Hybrid COM 1 design, users can readily choose one type of com port to use. Through the GSDML file, it is easy to communicate with any standard PROFINET IO controller.

- Protocol: PROFINET IO Device
- PROFINET Conformance Class B and RT Class 1
- Cyclic Time: 1 ms (min)
- Generic GSDML File Provided (Version 2.25)
- Max length of in/output data is 512/384 Bytes
- Provide LED indicators
- 4 kV Contact ESD protection for any terminal
- Wide range of power input (+10 VDC ~ +30 VDC) and operating temperature (-25°C ~ +75°C)

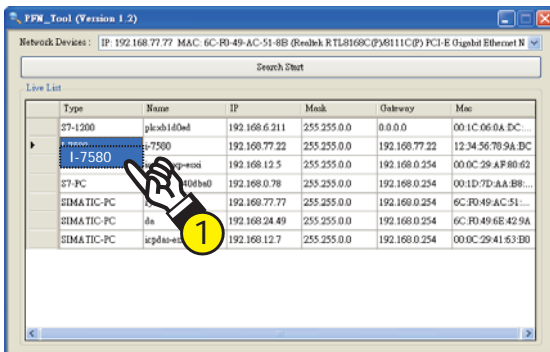

- Show PROFINET user parameters of the I-7580
- Show diagnostic messages of the I-7580
- Provide comport test function
- Provide Communication Log of comport

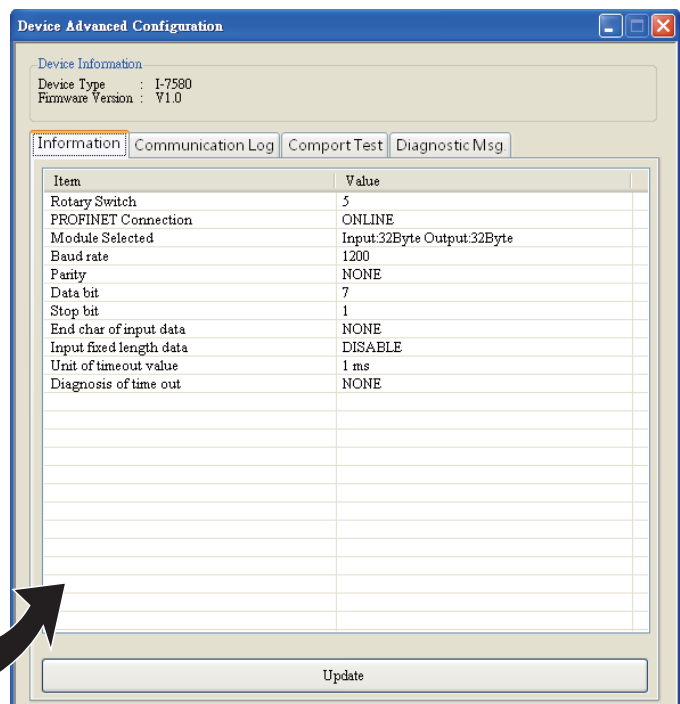
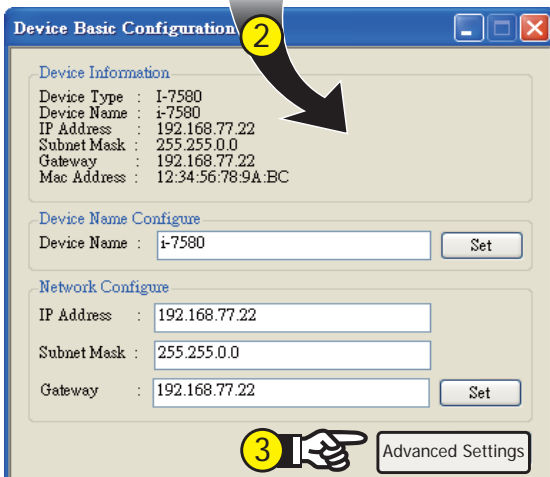

### PROFINET Gateways

The PROFINET gateway is used to solve data-exchanging between different communication network and PROFINET network. If it is necessary to integrate different communication protocols to PROFINET, the PROFINET gateway is helpful. The application architectures as following figures provide the examples to show when and how to apply these products.

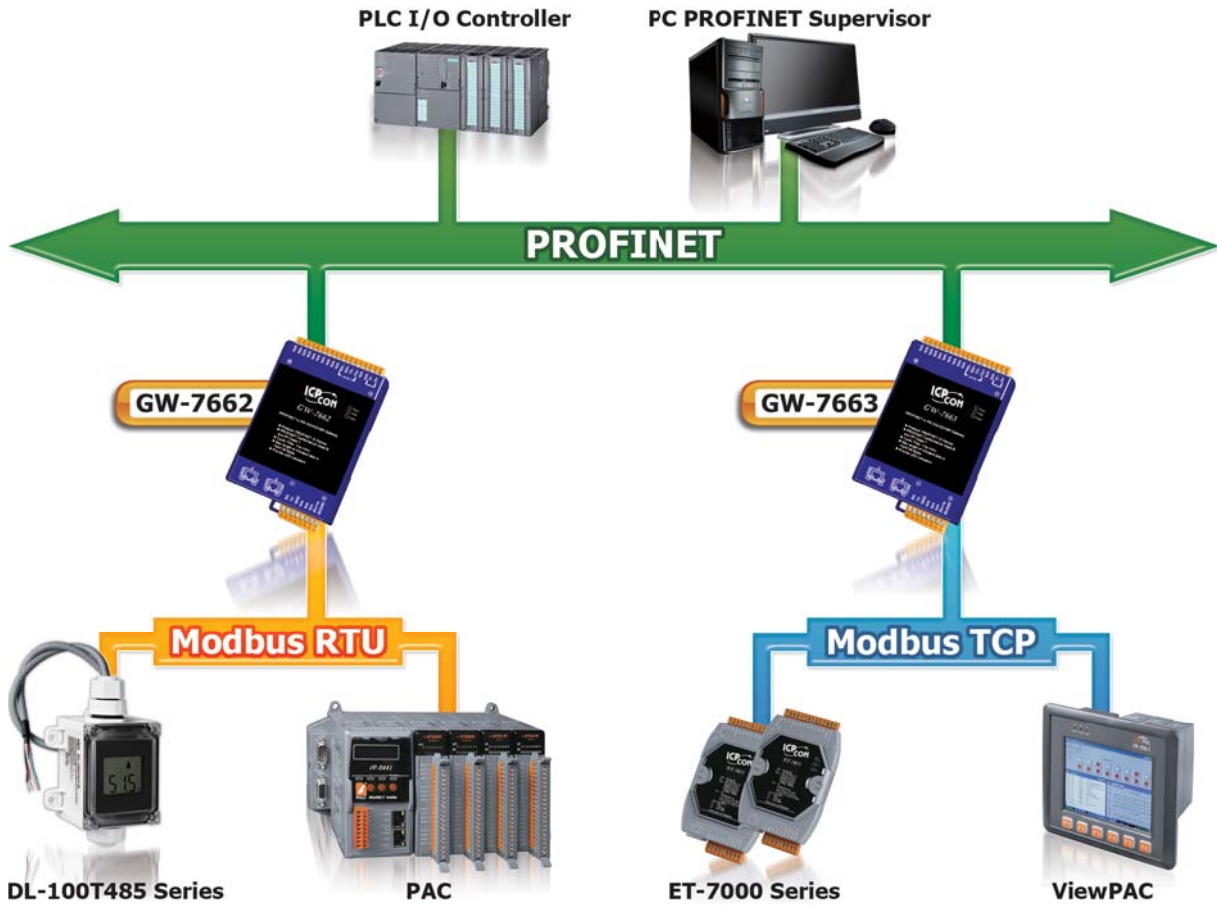

### Specifications >>>

Models		GW-7662	GW-7663
Pictures		<b>NEW</b>	<b>NEW</b>
		PROFINET to Modbus RTU/ASCII Gateway	PROFINET to Modbus TCP Gateway
PROFINET	Protocol	IO device	
	Conformance Classes	Class B	
	RT Classes	Class 1	
	Cyclic Time	1 ms	
COM port	Type	1 x RS-232/422/485	N/A
	Baud Rate (bps)	2.4 k ~ 115.2 k	N/A
	Protocol	Modbus RTU/ASCII, Master/Slave	N/A
Ethernet Port	Speed	10/100M	
	Protocol	PROFINET IO device	Modbus TCP Server/ Client & PROFINET IO device



NEW

## PROFINET to Modbus RTU Master Gateway

### GW-7662



The GW-7662 gateway is a PROFINET IO device that allows the PROFINET controller to access the Modbus RTU devices. In the Modbus network, the GW-7662 can be a Modbus master to access the Modbus slaves, can be a Modbus slave provide the data from the PROFINET controller. The flexible design lets the GW-7662 widely applying in the many applications.

- Wide range of power input (+10 ~ +30 VDC) and operating temperature (-25°C ~ +75°C)
- Support several kinds of baud for COM1 from 2.4 ~ 115.2 kbps
- Max length of in/output data is 512/512 Bytes
- PROFINET Conformance Class B and RT Class 1
- Generic GSDML File Provided (Version 2.25)
- 4 kV Contact ESD protection for any terminal
- Support Modbus RTU/ASCII protocol
- Support Modbus Master and Slave mode
- Protocol: PROFINET IO Device
- Cyclic Time: 1 ms (min)
- Provide LED indicators

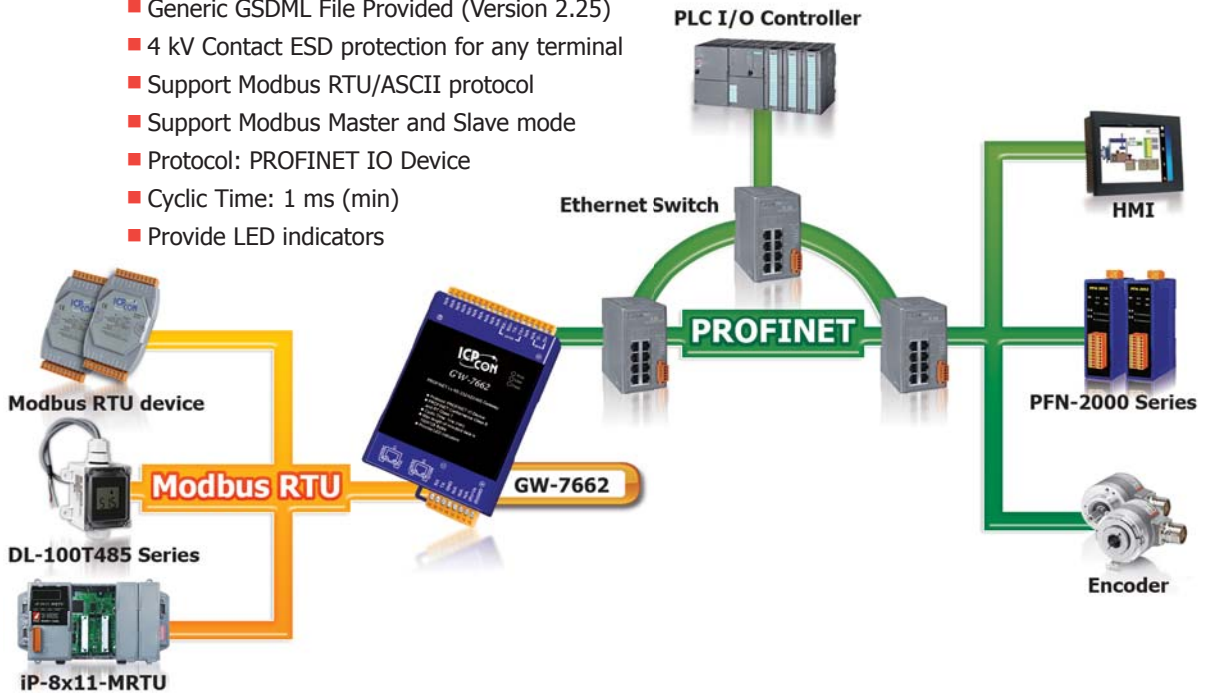

NEW

## PROFINET to Modbus TCP Master Gateway

### GW-7663



The GW-7663 is used for data-exchange between the Modbus TCP network and the PROFINET network. It provides the Modbus TCP client and server functions. Therefore, the GW-7663 can satisfy most of the applications of the data transfer between Modbus and PROFINET.

- Max length of in/output data is 512/512 Bytes
- PROFINET Conformance Class B and RT Class 1
- 4 kV Contact ESD protection for any terminal
- Generic GSDML File Provided (Version 2.25)
- Wide range of power input (+10 ~ +30 VDC) and operating temperature (-25°C ~ +75°C)
- Protocol: PROFINET IO Device
- Support Modbus TCP protocol
- Support Modbus Master and Slave mode
- Cyclic Time: 1 ms (min)
- Provide LED indicators

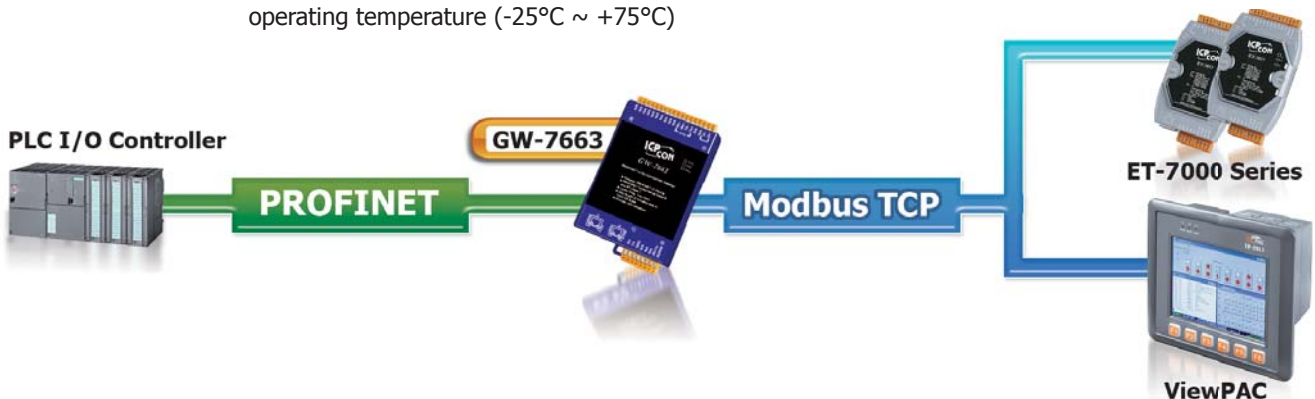





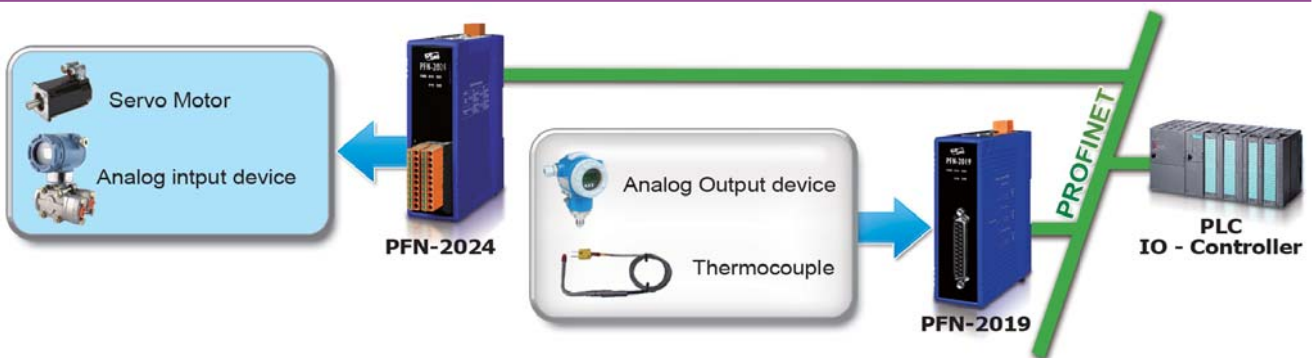

## Analog Input & Output Modules

Model Name	PFN-2019	PFN-2024
Pictures		
	10-Ch AI Module	4-Ch AO Module
<b>Analog Input</b>		
Channels	10 (Differential)	
Sensor Type	Thermocouple (J, K, T, E, R, S, B, N, C)	
Voltage Input Range	±15 mV, ±50 mV, ±100 mV, ±500 mV, ±1 V, ±2.5 V, ±5 V, ±10 V	
Current Input Range	±20 mA, 0 ~ +20 mA, +4 mA ~ +20 mA (Jumper Selectable)	-
Resolution	16-bit	
Sampling Rate	10 Hz	
Accuracy	±0.1% of FSR	
EDS Protection	4 kV Contact for each channel	
<b>Analog Output</b>		
Channels		4
Voltage Output Range		0 ~ 5 V, ±5 V, 0 ~ 10 V, ±10 V
Current Output Range		0 ~ 20 mA, 4 ~ 20 mA
Resolution	-	14-bit
Accuracy	Voltage Output	±0.1% of FSR
	Current Output	±0.2% of FSR
ESD Protection		4 kV Contact for each channel
<b>PROFINET</b>		
Connector	2 x RJ-45, 10/100 BaseTX	
Protocol	PROFINET IO	
Service	RTC, RTA, CL-RPC, DCP, LLDP	
Conformance	Class B	
RT	Class 1	
Cycle Time	1 ms (min.)	
Generic GSDML File	Ver. 2.25	
<b>System</b>		
ESD (IEC 61000-4-2)	4 kV	
EFT (IEC 61000-4-4)	1 kV	
Surge (IEC 61000-4-5)	1 kV	
Intra-Module Isolation, Field-to-Logic	3750 Vrms	
Power Input	+10 ~ +30 VDC	





## Digital Input & Output Modules

Digital Input & Output Module						
Model Name	PFN-2042	PFN-2051	PFN-2052	PFN-2053	PFN-2055	PFN-2060
Pictures	16-Ch DO Module	16-Ch DI Module	8-Ch DI Module	16-Ch DI Module	8-Ch DI, 8-Ch DO Module	6-Ch DI, 6-Ch Relay Module
						
<b>Digital Input</b>						
Channels		16	8	16	8	6
Contact		Dry + Wet	Wet	Dry	Dry + Wet	Dry + Wet
Sink/Source (NPN/PNP)		Sink/Source	Sink/Source	Source	Sink/Source	Sink/Source
Wet Contact	On Voltage Level	+10 ~ 50 VDC	+4 ~ 30 VDC	-	+10 ~ 50 VDC	+10 ~ 50 VDC
	Off Voltage Level	+4 VDC Max.	+1 VDC Max.	-	+4 VDC Max.	+4 VDC Max.
Dry Contact	On Voltage Level	Close to GND	-	Close to GND	Close to GND	Close to GND
	Off Voltage Level	Open	-	Open	Open	Open
Input Impedance		10 kΩ, 0.5W	3KΩ, 0.3W	-	10 kΩ, 0.5W	10 kΩ, 0.5W
<b>Digital Output</b>						
Channels	16				8	6
Type	Open Collector				Open Collector	Power Relay
Sink/Source (NPN/PNP)	Sink				Sink	Form A
Load Voltage	+3.5 ~ +50 VDC				+3.5 ~ +50 VDC	30 VDC/125 VAC
Max. Load Current	700 mA/Channel	-	-	-	700 mA/Channel	2 A @ 30 VDC, 0.6 A @ 125 VAC
Overvoltage Protection	60 VDC				60 VDC	-
Overload Protection	Yes				Yes	-
Power-on Value	Yes				Yes	Yes
Safe Value	Yes				Yes	Yes
<b>PROFINET</b>						
Connector	2 × RJ-45, 10/100 BaseTX					
Protocol	PROFINET IO					
Service	RTC, RTA, CL-RPC, DCP, LLDP					
Conformance	Class B					
RT	Class 1					
Cycle Time	1 ms (min.)					
Generic GSDML File	Ver. 2.25					
<b>System</b>						
ESD (IEC 61000-4-2)	4 kV					
EFT (IEC 61000-4-4)	1 kV					
Surge (IEC 61000-4-5)	1 kV					
Intra-Module Isolation, Field-to-Logic	3750 V					
Power Input	+10 ~ +30 VDC					

### 3.5 Ethernet Device Servers

In order to integrate the information from the field into the enterprise systems easily, the Ethernet communication is widely applied in the industrial and automation applications. Beside the Ethernet/IP, PROFINET, and EtherCAT, ICP DAS also announces a series of the general purpose products and Modbus-related products as the converters, gateways, I/O modules and switches. The device server series products let the serial communication products quickly join the Ethernet network. For the I/O control and monitor requirements, the Modbus I/O slaves and intelligent I/O modules provides simple methods to achieve the purposes. If you need to deploy an Ethernet network, the Ethernet switch can fit the applications.



#### Introduction

The ICP DAS Programmable Device Server is designed to bring network connectivity to your serial devices. The programmable features allow developers to quickly build custom applications that turn "dull" serial devices into "intelligent" devices right away without modifying their hardware or software configuration.

With extensive experience accumulated over many years, a great number of serial devices such as PLCs, bar code readers, RFID readers, meters and motion controllers, etc., have been widely used in various applications. As the advances in communication technologies in recent years, continue to drive optimization of data accessibility and remote operation ability, a wide variety of industries have begun to feel the urge to upgrade their latency serial communications to Ethernet network connections. The ICP DAS PDS series of products are your best choice for implementing this scenario in a robust, reliable and cost-effective way.

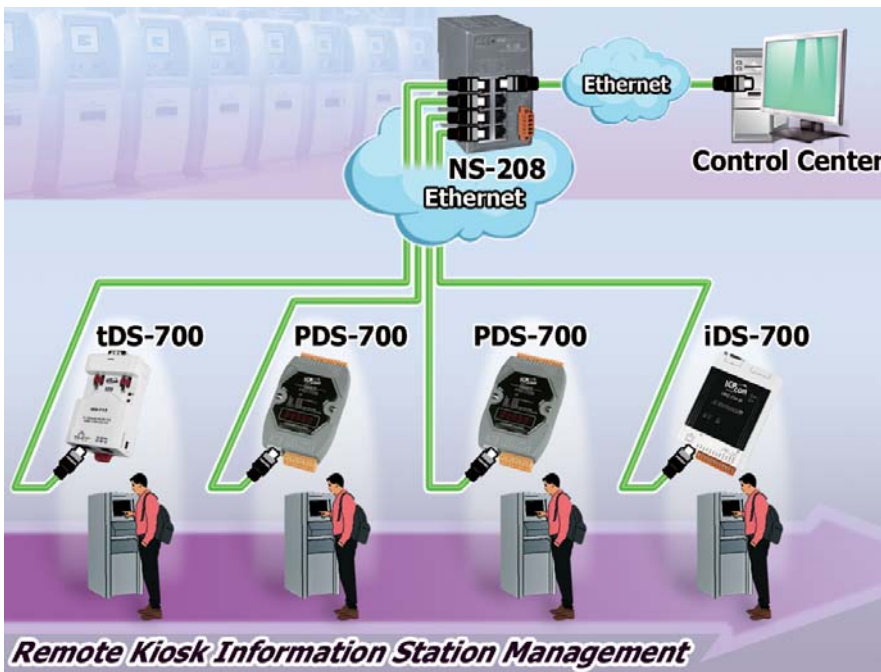

The VxComm Driver creates virtual COM port(s) on 32-bit and 64-bit Windows XP/2012/7/8/10 systems and maps them to the remote serial port(s) of the PDS/DS series. The user's serial client programs need to only be changed to the virtual COM port access the serial devices that are allocated on the Internet or Ethernet network via the PDS/DS series.

- 1.) High Reliability Industrial Ethernet Switch Catalog
- 2.) Industrial Ethernet Switch Additional Products Catalog

- Managed Ethernet Switches
- Media Converters
- IP67 Waterproof Switches
- Real-time Redundant Ring Ethernet Switches
- Unmanaged Ethernet Switches PoE Ethernet Switches
- Cyber-Ring Ethernet Self-healing Technology

Or refer to <http://www.icpdas.com/root/support/catalog/catalog.html>

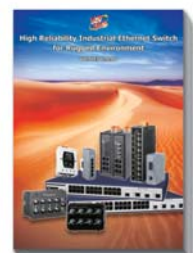



## Selection Guide

### Comparison Table of Device Server and Modbus Gateway

Features	iDS	PPDS	PDS	DS	tDS	tGW
Picture						
PoE	Yes	Yes	–	–	Yes	Yes
Programmable	Yes	Yes	Yes	–	–	–
Virtual COM	Yes	Yes	Yes	Yes	Yes	–
Modbus Gateway	–	Yes	–	–	–	Yes
Multi-client	Yes	Yes	Yes	Yes	–	Yes
SNMP	Yes	–	–	–	–	–
Application Mode	Virtual COM TCP Server TCP Client UDP Pair Connection RFC2217 Telnet Modem Emulator	Virtual COM TCP Server TCP Client Pair Connection Modbus TCP Slave	Virtual COM TCP Server TCP Client Pair Connection	Virtual COM TCP Server TCP Client Pair Connection	Virtual COM TCP Server TCP Client Pair Connection	Modbus TCP Master Modbus TCP Slave Modbus UDP Master Modbus UDP Slave Pair Connection
Remarks	Intelligent	Professional	Powerful	Isolation for DS-715	Cost-effective, Entry-level	Cost-effective, Entry-level

#### ✓ iDS Series – Intelligent Device Server

Series	Ethernet	Virtual COM	Virtual I/O	Programmable	Modbus	Casing
<b>iDS-700</b>	10/100 M, PoE	Yes	–	Yes	–	Plastic
<b>iDS-700M</b>						Metal

#### ✓ PPDS Series – Programmable Device Server and Modbus Gateway with PoE

Series	Ethernet	Virtual COM	Virtual I/O	Programmable	Modbus	Casing
<b>PPDS-700-MTCP</b>	10/100 M, PoE	Yes	Yes	Yes	Yes	Plastic
<b>PPDSM-700-MTCP</b>						Metal
<b>PPDS-700-IP67</b>			–		–	IP67 Waterproof Plastic

#### ✓ PDS Series – Programmable Device Server

Series	Ethernet	Virtual COM	Virtual I/O	Programmable	Modbus	Casing
<b>PDS-700</b>	10/100 M	Yes	Yes	Yes	–	Plastic
<b>PDSM-700</b>						Metal
<b>PDS-220Fx</b>	100 Base-FX, Fiber		–		–	–
<b>PDS-5000-MTCP</b>	10/100 M Ethernet Switch	–	–	–	Yes	Plastic

#### ✓ DS, tDS & tGW Series – Non-Programmable Device Server and Modbus Gateway

Series	Ethernet	Virtual COM	Virtual I/O	Multi-client	Modbus	Casing	Remarks
<b>DS-700</b>	10/100 M	Yes	–	Yes	–	Plastic	Isolation for DS-715
<b>tDS-700</b>	10/100 M, PoE			–	–		–
<b>tGW-700</b>		–	–	–	Yes	Yes	–

### 3.6 BACnet/IP Products

BACnet, a data communication protocol for building automation and control networks, is developed under the auspices of the American Society of Heating, Refrigerating and Air-Conditioning Engineers (ASHRAE). It is an American national standard, a European standard, an national standard in more than 30 countries, and an ISO global standard. This protocol is comprehensive applied in vastly different applications such as heating, ventilating, and air-conditioning control, lighting control, access control, and fire detection systems. The BACnet protocol also provides mechanisms for computerized building automation devices to exchange information, regardless of the particular building service they perform.

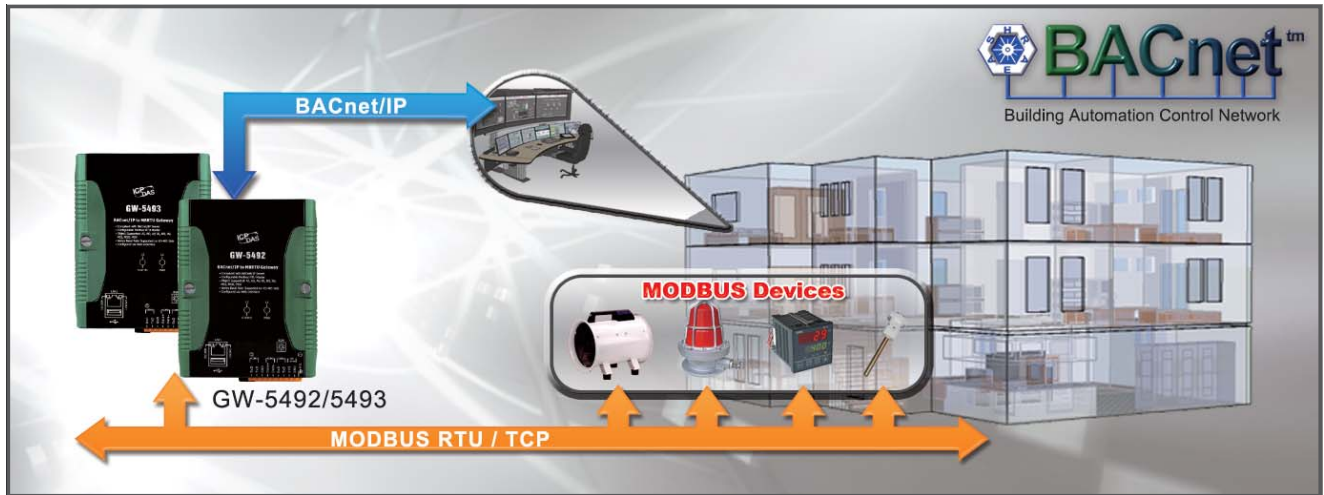

#### Features:

- Designed specifically for building automation control
- Conformance to ANSI/ASHRAE standard 135-2008 or ISO 16484-5
- A completely non-proprietary open communication software standard
- Support several different physical and link layers (BACnet/IP, Ethernet, ARCNET, MS/TP, PTP and LonTalk)
- All data in a BACnet system is represented in terms of "objects", "properties" and "services"

BACnet Stack Layers					OSI Layer	
BACnet Defined					Application (7)	Handles the actual interface with the user's application program
BACnet Application Layer					Network (3)	Establishes logical circuits and routing between two machines
BACnet Network Layer					Data-Link (2)	Controls orderly access to the physical medium
ISO 8802-2 (IEEE 8802.3) Type 1	MS/TP	PTP	LonTalk	BVLL	Physical (1)	Transmits and receives individual bits on the physical medium
ISO 8802-3 Ethernet	ARCNET	EIA 485		UDP/IP		
		EIA 232		IP Supporting Data link		



Object_Name	SAMPLE OBJECT
Object_Type	ANALOG INPUT
Present_Valus	72.3
Status_Flags	Out-of Service
High_Limit	78.0
Low_Limit	68.0

#### Selection Guide

Model Name	Description
<b>BACnet/IP Gateway</b>	GW-5492 BACnet/IP Server to Modbus RTU Master Gateway
	GW-5493 BACnet/IP Server to Modbus TCP Client Gateway
	GW-5429 Modbus RTU Slave to BACnet/IP Client Gateway
	GW-5439 Modbus TCP Server to BACnet/IP Client Gateway
<b>BACnet/IP I/O Modules</b>	BNET-5304 BACnet/IP I/O Module with 6-Ch AI, 1-Ch AO, 4-Ch DI, 4-Ch DO
	BNET-5310 BACnet/IP I/O Module with 4-Ch AI, 2-Ch AO, 3-Ch DI, 3-Ch DO



## Case Studies

### Commercial Building Automation System

#### Product: GW-5492

The user used the SCADA, InduSoft Web Studio, with BACnet/IP driver to integrate with BACnet/IP devices and controllers in a commercial building including 210 air volume terminals, 22 air handling units, 3 chillers... etc. Using GW-5492, the user was able to integrate those Modbus RTU devices to BACnet/IP network. By doing these is to eliminate multiple protocols on the network and easy maintenance in the future. The system monitors and controls nearly 2500 physical inputs and outputs which are connected to the InduSoft residing on the BACnet/IP networks. InduSoft also configured a powerful feature that showed facility personnel peak demand trends on energy usage and sequence unit operations to minimize energy consumption. The building retains 10% energy savings each month after new system installed.

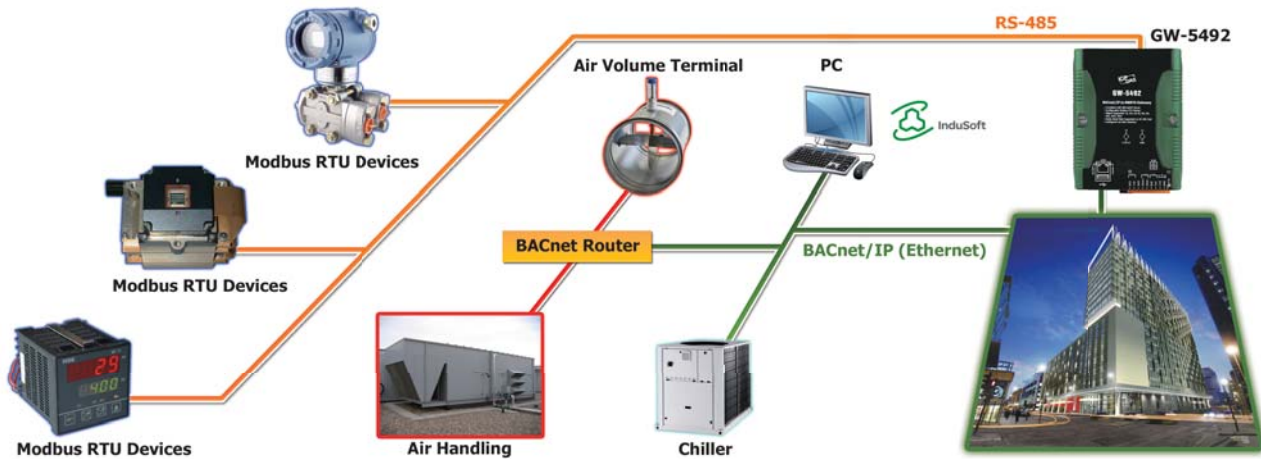

### Building Automation of a Medical Center

#### Product: GW-5493

The user from a medical center used the SCADA, InduSoft Web Studio, to integrate numerous third party devices using BACnet/IP protocol – including the hospital emergency power transfer switches, water booster pumps, and HVAC system. For those existing Modbus TCP devices, the user added the GW-5493 BACnet/IP to Modbus gateway in order to make the devices accessible using BACnet/IP protocol. The system integration provides the information necessary to make complex decisions driving energy savings and properly monitor the equipment. With GTM-201, the system allows the operator to receive alarms and monitoring points via SMS messages. The building automation system also trends data regularly so that the client can use the information to track costs and troubleshoot equipment from historical data.

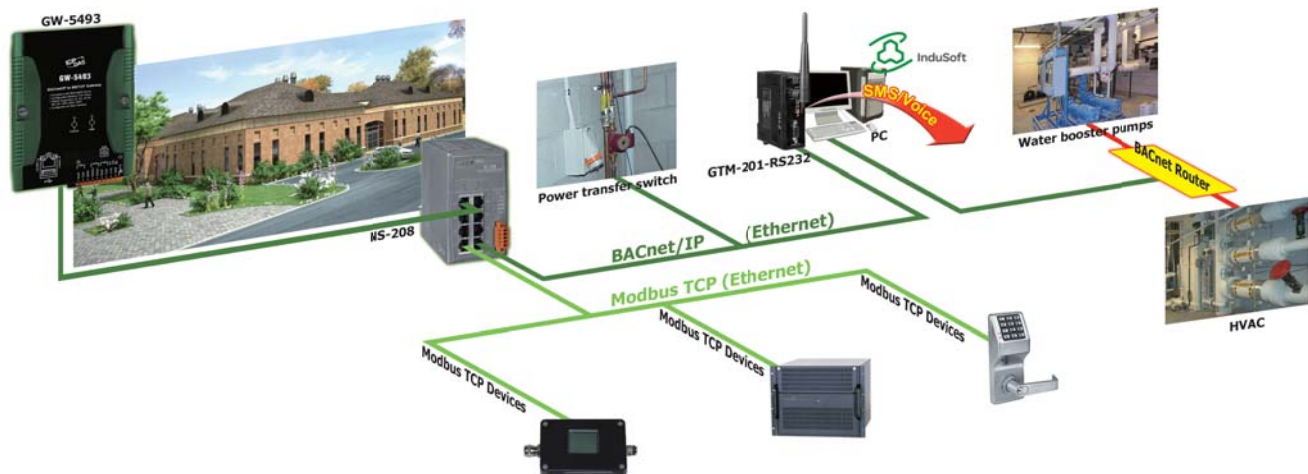



## BACnet Gateways

NEW

### BACnet/IP Server to Modbus Master Gateway

#### GW-5492 GW-5493



GW-5492 and GW-5493 is a fully configurable universal BACnet/IP to Modbus RTU/TCP gateway. The GW-549x includes BACnet/IP Server and Modbus RTU Master (GW-5492) or TCP Client (GW-5493) which is used to make Modbus devices accessible on a BACnet network. BACnet (Building Automation and Control Networking) protocol has been designed specifically to meet the communication needs of building automation and control systems for applications such as heating, ventilating. The GW-549x contains a large number of BACnet objects gives you flexibility in mapping Modbus registers to any combination of BACnet objects. Multiple BIBBs are supported. All the data transfer is configurable using a standard Web browser.

Available soon

### Modbus Slave to BACnet/IP Client Gateway

#### GW-5429 GW-5439



GW-5429 and GW-5439 is a fully configurable universal BACnet/IP to Modbus RTU/TCP gateway. The GW-54x9 includes BACnet/IP Client and Modbus RTU Slave (GW-5429) or TCP Server (GW-5439) which is used to make BACnet devices accessible on a Modbus network. BACnet (Building Automation and Control Networking) protocol has been designed specifically to meet the communication needs of building automation and control systems for applications such as heating, ventilating. The GW-54x9 contains a large number of BACnet objects gives you flexibility in mapping Modbus registers to any combination of BACnet objects. Multiple BIBBs are supported. All the data transfer is configurable using a standard Web browser.



#### Features >>>

- No Programming Required
- BACnet/IP and Modbus register mapping configuration via web utility
- Fully compliant with BACnet/IP and Modbus
- Quickly and cost effectively integrate networks



#### BACnet Support >>>

<b>Object</b>	Binary Input, Binary Output, Binary Value, Analog Input, Analog Output, Analog Value, Multi-State Input, Multi-State Output, Multi-State Value, Device
<b>BIBB</b>	DS-RP-B, DS-RPM-B, DS-WP-B, DS-WPM-B, DS-COV-B, DM-DDB-B, DM-DOB-B, DM-DCC-B, DM-TS-B, DM-UTC-B, DM-RD-B



#### Utility Features >>>



- Configured via standard Web browser
- Provide Modbus and BACnet configuration interface
- Update firmware remotely
- Easily mapping Modbus Register to BACnet object



#### Modbus Support >>>

Code	Type	Description
01	Read Coil Status	Read the ON/OFF status of discrete outputs in the slave
02	Read Input Status	Read the ON/OFF status of discrete inputs in the slave
03	Read Holding Registers	Read the binary contents of holding registers in the slave
04	Read Input Registers	Read the binary contents of input registers in the slave
05	Force Single Coil	Write a single output to either ON or OFF in the slave
06	Preset Single Register	Write an integer value into a single register in the slave
15	Force Multi Coils	Write each coil in the sequence of coils to either ON or OFF in the slave
16	Preset Multi Registers	Write a block of contiguous registers in the slave



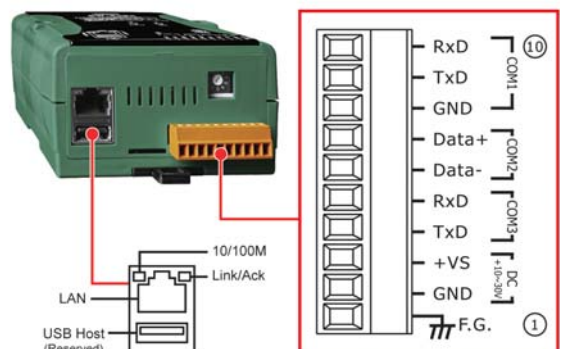

#### Pin Assignments >>>







## BACnet/IP I/O Modules

Model Name	BNET-5304	BNET-5310
Pictures	Multi-function BACnet/IP Module 	Multi-function BACnet/IP Module 
<b>System</b>		
COM1	Reserved	
Ethernet	10/100 Base-TX	
Security	ID and Password	
Built-in Watchdog	Yes	
LED Indicator	Power and Status	
<b>Protocol</b>		
BACnet	BACnet/IP	
BACnet Objects	1 Device, 6 AI, 1 AO, 4 BI, 4 BO	1 Device, 4 AI, 2 AO, 3 BI, 3 BO
BIBB	DS-RP-B, DS-RPM-B, DS-WP-B, DS-WPM-B, DS-COV-B, DM-DDB-B, DM-DOB-B, DM-DCC-B, DM-TS-B, DM-UTC-B, DM-RD-B	
<b>Analog Input</b>		
Channel	6	4
Wiring	Single-Ended	Differential
Range	±5 V, 0 ~ +5 V	±10 V
Resolution	12-bit	
Sampling Rate	4 KHz	
Input Impedance	1 MΩ	
Overvoltage Protection	±30 VDC	
Isolation	Non-isolated	
<b>Analog Output</b>		
Channel	1	2
Range	±5 V	±10 V
Resolution	12-bit	
Output Capacity	20 mA	
Isolation	Non-isolated	
<b>Digital Input</b>		
Channels	4	3
Contact	Dry	
Dry Contact	On Voltage Level	Close to GND
	Off Voltage Level	Open
Overvoltage Protection	30 VDC	
<b>Digital Output</b>		
Channels	4	3
Type	Open Collector	
Sink/Source (NPN/PNP)	Sink	
Load Voltage	+10 VDC ~ 40 VDC	
Max. Load Current	200 mA/channel at 25°C	
Overload Protection	1.4 A	
<b>Environmental</b>		
Dimensions (W x L x H)	91 mm x 132 mm x 52 mm	
Operating Temp	-25 ~ +75°C	
Storage Temp.	-30 ~ +85°C	
Humidity	5 ~ 90% PH, Non-condensing	
Power Input Range	+10 V to +30 VDC	
Power Consumption	4.8 W (0.2 A @ 24 Vdc)	

### 3.7 Industrial Ethernet/Fiber Switches

Unmanaged Industrial PoE Ethernet Switch						
Model Name	NS-105PSE	tNS-200IN-24V	NS-205PSE-24V	NSM-208PSE-24V	NSM-205GHP	NSM-208PSE-M12
Pictures						
Speed	10/100 M				10/100/1000 M	10/100 M
Ethernet Port	1	1	1	-	1	-
Ethernet Port with PoE	4	1	4	8	4	8
Casing	Plastic			Metal with IP30		Metal with IP40
Operating Temperature	-40 ~ +75°C					
Power Input	+46 VDC ~ +53 VDC	+18 VDC ~ +32 VDC			+18 VDC ~ +60 VDC	+46 V ~ +53 VDC
Dimensions (W x L x H)(Units: mm)	76 x 38 x 118	52 x 86 x 27	31 x 113 x 157	25 x 119 x 168	25 x 119 x 168	190 x 56 x 100

Unmanaged Industrial Ethernet Switch						
Model Name	NS-205AG	NS-208-IP67	NS-105A	NS-208A	NSM-316G	NSM-208-M12
Pictures						
Speed	10/100/1000 M	10/100 M				
Port	5	8	5	8	16	8
Casing	Plastic				Metal with IP30	Metal with IP40
Operating Temperature	-40 ~ +75°C	-10 ~ +60°C	-40 ~ +75°C			
Power Input	+12 VDC ~ +48 VDC	+12 VDC ~ +53 VDC	+12 VDC ~ +48 VDC			+12 VDC ~ +53 VDC
Dimensions (W x L x H)(Units: mm)	33 x 78 x 107	190 x 155 x 104	76 x 38 x 118	31 x 113 x 157	51 x 154 x 118	190 x 56 x 100

Unmanaged Industrial 10/100 Base-T(X) with 100 Base-FX Fiber Switch							
Model Name	NSM-205AFT-T	NSM-205AFC-T	NSM-205AFCS-T	NSM-206AFT-T	NSM-206AFC-T	NSM-206AFCS-T	
Pictures							
Fiber Port	Mode	Multi-mode	Multi-mode	Single-mode	Multi-mode	Multi-mode	Single-mode
	Connector	ST	SC	SC	ST	SC	SC
	Speed	100 M					
Ethernet	Port	1			2		
	Speed	10/100 M					
Ethernet	Port	4					
	Casing	Metal					
Operating Temperature	-30 ~ +75°C						
Power Input	+12 VDC ~ +48 VDC						
Dimensions (W x L x H)(Units: mm)	25 x 133 x 168						

1.) High Reliability Industrial Ethernet Switch Catalog

2.) Industrial Ethernet Switch Additional Products Catalog

- Managed Ethernet Switches
- Media Converters
- IP67 Waterproof Switches
- Real-time Redundant Ring Ethernet Switches
- Unmanaged Ethernet Switches PoE Ethernet Switches
- Cyber-Ring Ethernet Self-healing Technology

Or refer to <http://www.icpdas.com/root/support/catalog/catalog.html>

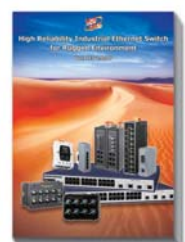

# NS-205PSE-IP67 Series

Industrial 5-Port Unmanaged IP67 Ethernet Switch with PoE

# NS-205-IP67 Series

Industrial 5-Port Unmanaged IP67 Ethernet Switch



NS-205PSE-IP67 Series/NS-205-IP67 Series							For NS-205PSE-IP67/ NS-205PSE-IP67/DIN			For NS-205-IP67/ NS-205-IP67/DIN		For NS-205-IP67/DIN/ NS-205PSE-IP67/DIN	
-10 ~ +60 Wide Temperature	Wall Mount	IP67	CE	FCC	RoHS	WEEE	+46 ~ +53 Input Voltage	10/100 LAN x1	PoE 10/100 PoE + LAN x4	10/100 LAN x5	DIN-Rail Mount		

## Introduction

The NS-205PSE-IP67/NS-205-IP67 is designed for industrial applications in harsh environments. The rugged RJ-45 ensure tight, robust connections, and guarantee reliable operation, even for applications that are subject to high vibration and shock. The NS-205PSE-IP67 PoE switch provides 5 fast Ethernet with 4 IEEE 802.3af compliant PoE ports. The switch is classified as power source equipment (PSE) and provides up to 15.4 W of power per port.

The Ethernet switch supports IEEE 802.3/802.3u/802/3x with 10/100M, full/half-duplex, MDI/MDI-X auto-sensing, and provide an economical solution for your industrial Ethernet network.

## Appearance

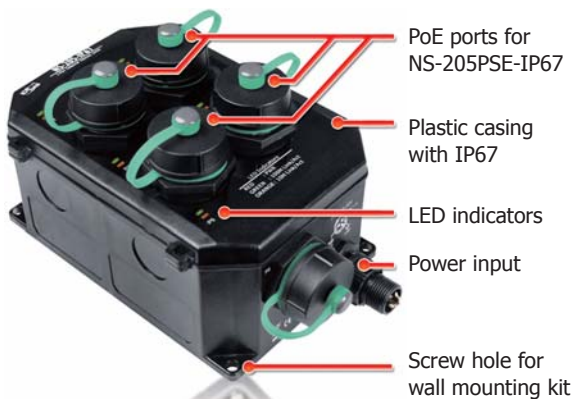

## Dimensions (Units: mm)

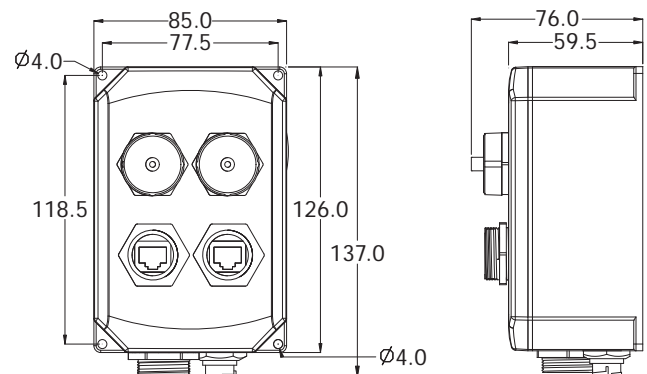

## Ordering Information

<b>NS-205PSE-IP67 CR</b>	Industrial 5-Port unmanaged IP67 Ethernet switch with PoE Includes IP67 RJ-45 Plug x 5, IP67 Power Plug x 1, Cap with Tether x 5 (RoHS)
<b>NS-205-IP67 CR</b>	Industrial 5-Port unmanaged IP67 Ethernet switch Includes IP67 RJ-45 Plug x 5, IP67 Power Plug x 1, Cap with Tether x 5 (RoHS)

# NS-208PSE-IP67

Industrial 8-Port Unmanaged IP67 Ethernet Switch with PoE

# NS-208-IP67

Industrial 8-Port Unmanaged IP67 Ethernet Switch



NS-208PSE-IP67/NS-208-IP67 Series							For NS-208PSE-IP67		For NS-208-IP67	
-10 ~ +60 Wide Temperature	Wall & DIN-Rail Mount	IP67	CE	FCC	RoHS	WEEE	+46 ~ +53 Input Voltage	PoE 10/100 x 8	10/100 LAN	x 8

## Introduction

The NS-208PSE-IP67/NS-208-IP67 is designed for industrial applications in harsh environments. The rugged RJ-45 ensures tight, robust connections, and guarantees reliable operation, even for applications that are subject to high vibration and shock. The NS-208PSE-IP67 PoE switch provides 8 fast Ethernet with 8 IEEE 802.3af compliant PoE ports. The switch is classified as power source equipment (PSE) and provide up to 15.4 W of power per port.

The Ethernet switch supports IEEE 802.3/802.3u/802/3x with 10/100M, full/half-duplex, MDI/MDI-X auto-sensing, and provides an economical solution for your industrial Ethernet network.

## Appearance



## Dimensions (Units: mm)

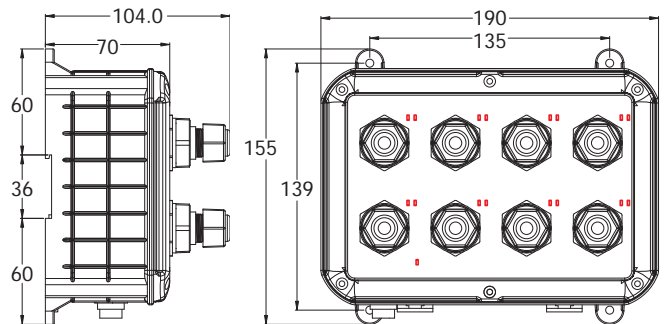

## Ordering Information

<b>NS-208PSE-IP67 CR</b>	Industrial 8-Port unmanaged IP67 Ethernet switch with PoE Includes IP67 RJ-45 Plug x 8, IP67 Power Plug x 1, Cap with Tether x 8 (RoHS)
<b>NS-208-IP67 CR</b>	Industrial 8-Port unmanaged IP67 Ethernet switch Includes IP67 RJ-45 Plug x 8, IP67 Power Plug x 1, Cap with Tether x 8 (RoHS)

# NSM-208-M12

EN50155 8-Port M12 Unmanaged Ethernet Switch

# NSM-208PSE-M12

EN50155 8-Port M12 Unmanaged PoE Ethernet Switch



NSM-208-M12/NSM-208PSE-M12 Series						For NSM-208PSE-M12		For NSM-208-M12	
-40 ~ +75 Wide Temperature	Wall Mount	IP40	EN50155	CE	FCC	+46 ~ +53 Input Voltage	PoE + LAN x 8	LAN x 8	

## Introduction

The NSM-208PSE-M12/NSM-208-M12 is designed for industrial applications in harsh environments. The M12 connectors ensure tight, robust connections, and guarantees reliable operation, even for applications that are subject to high vibration and shock.

The NSM-208PSE-M12 PoE switch provides 8 fast Ethernet M12 ports with 8 IEEE 802.3af compliant PoE ports. The switch is classified as power source equipment (PSE) and provide up to 15.4 W of power per port.

The Ethernet switch supports IEEE 802.3/802.3u/802/3x with 10/100M, full/half-duplex, MDI/MDI-X auto-sensing, and provides an economical solution for your industrial Ethernet network.

The NSM-208-M12 provides a wide +12 VDC ~ +53 VDC power range to fit all the common power standards found in industrial automation, without external power converters. The wide power input lowers installation and maintenance costs.

## Appearance

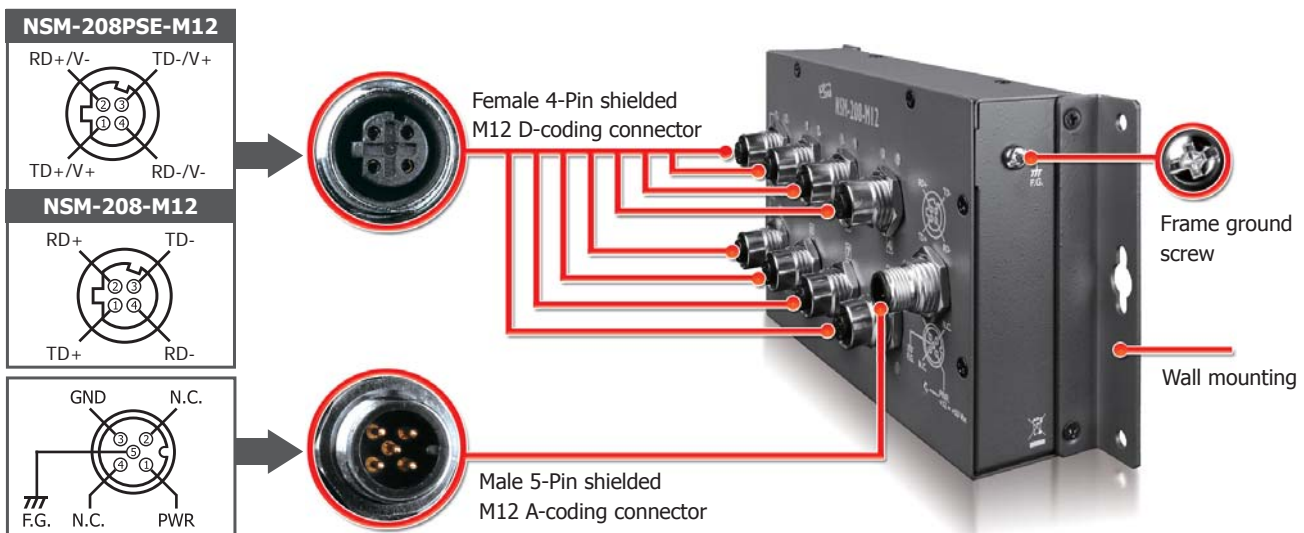

## Specifications ▶▶▶

Models	NSM-208PSE-M12	NSM-208-M12
<b>Technology</b>		
Standards	IEEE 802.3, 802.3u, 802.3x, 10/100 Base-T(X) auto negotiation speed, F/H duplex mode, and auto MDI/MDI-X connection	
Processing Type	Store & forward	
MAC Addresses	1024	
Memory Bandwidth	3.2 Gbps	
Frame Buffer Memory	512 Kbit	
Flow Control	IEEE 802.3x flow control, back pressure flow control	
<b>Interface</b>		
LED Indicators	PWR, Link/Act, Power Device is detected	PWR, Link/Act
Ethernet Isolation	1500 Vrms 1 minute	
Connector	Female 4-Pin shielded M12 D-coding connector x 8	
<b>Power Input</b>		
Input Voltage Range	+46 VDC ~ +53 VDC	+12 VDC ~ +53 VDC
Power Consumption	0.12 A @ 48 VDC without PD loading 3.0 A @ 48 VDC with PD full loading	0.12 A @ 48 VDC
Protection	Power reverse polarity protection	
Connector	Male 5-Pin shielded M12 A-coding connector x 1	
<b>PoE Technology</b>		
PoE Compliance	100% IEEE 802.3af compliant	
PoE Classification	PSE (Power Sourcing Equipment)	
PoE Voltage	+48 VDC depending on power input	
PoE Power	Up to 15.4 W per port	-
PoE Operation	Automatic detection and power management	
PoE Pin Assignments	V+ (Pin 1, 3), V- (Pin 2, 4)	
PoE Disconnect Mode	DC disconnect	
<b>Mechanical</b>		
Casing	Metal with IP40	
Dimensions (W x L x H)	190 mm x 56 mm x 100 mm	
Installation	Wall Mounting	
<b>Environmental</b>		
Operating Temperature	-40 ~ +75°C	
Storage Temperature	-40 ~ +85°C	
Ambient Relative Humidity	10 ~ 95% RH, Non-condensing	

## Dimensions (Units: mm) ▶▶▶

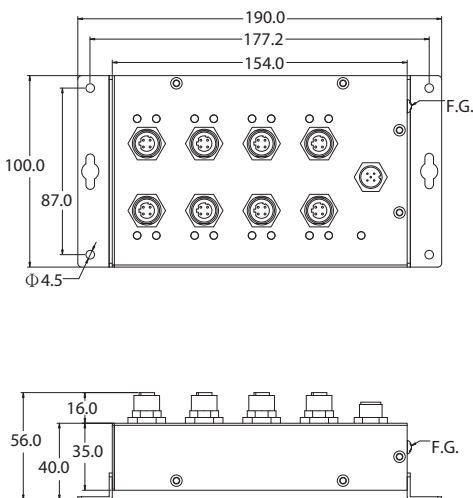

## Ordering Information ▶▶▶

<b>NSM-208-M12 CR</b>	EN50155 8-Port M12 Unmanaged Ethernet Switch (RoHS) Includes M12D-4P-IP68 x 8, A-CAP-M12M x 8, M12A-5P-IP68 and A-CAP-M12F x 1		
<b>NSM-208PSE-M12 CR</b>	EN50155 8-Port M12 Unmanaged PoE Ethernet Switch (RoHS) Includes M12D-4P-IP68 x 8, A-CAP-M12M x 8, M12A-5P-IP68 and A-CAP-M12F x 1		
M12D-4P-IP68	A-CAP-M12M	M12A-5P-IP68	A-CAP-M12F
4PIO1K0000001	4PIO1K0000002	4PIO1K0000003	4PIO1K0000004
To get high quality M12 cable, please refer to <a href="http://www.balluff.com">http://www.balluff.com</a>			

## Accessories ▶▶▶

MDR-60-48	48 V/1.25 A, 60 W Power Supply with DIN-Rail Mounting
DIN-KA52F-48	48 V/0.52 A, 25 W Power Supply with DIN-Rail Mounting
DR-120-48	48 V/2.5 A, 120 W Power Supply with DIN-Rail Mounting

### 3.8 Ethernet I/O Modules (Modbus TCP/UDP Slave)

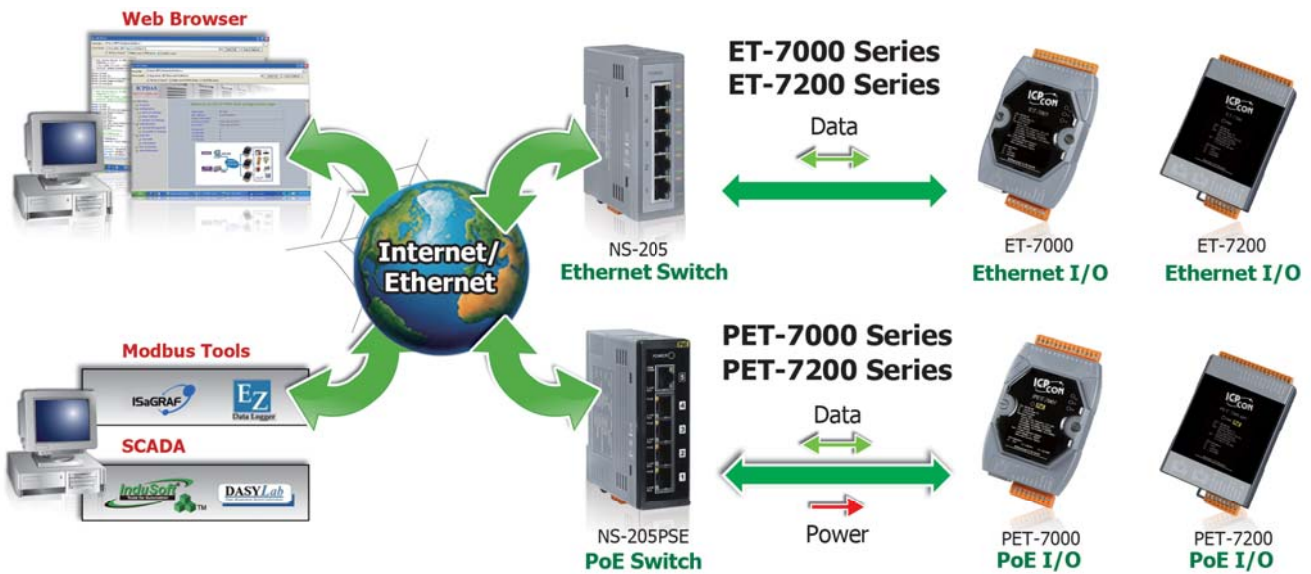

Although the RS-485 remote I/O module is still selling well, we found more and more demand of Ethernet based remote I/O modules. Our Ethernet remote I/O modules support Modbus TCP, Modbus UDP protocol. We also provide web HMI, Web server, OPC server, security mechanism..etc. According to different application, we have developed various Ethernet I/O modules, such as palm-size ET-7000/PET-7000 series, ET-7200/PET-7200 series and tiny-size tET/tPET series. The module has diversified I/O interface, such as overvoltage-protection analog input module, relay output, digital input/output, counter, timer. The brief comparison is as the following table. Besides those regular Ethernet I/O modules, we can also provide some ODM modules.

Model Name	tET/tPET Series	ET-7000 PET-7000	ET-7200 PET-7200
Pictures			
<b>Communication</b>			
Ethernet	10/100 M, RJ-45 x 1	10/100 M, RJ-45 x 2	
Protocol	Modbus TCP, Modbus UDP		
Security	Web Password and IP Filter	ID, Password and IP Filter	
Max. Sockets	5	12	
Web Server	Yes	Yes	
User-defined Web pages	-	Yes (Web HMI)	
<b>I/O</b>			
I/O pins	10 pins	23 pins	26 pins
DI Counter	32-bit, 3.5 kHz	32-bit, 500 Hz	
Pair Connection	Yes (Polling/Push Mode)	Yes (Polling Mode)	
<b>Mechanical</b>			
Dimensions (W x L x D)	52 mm x 98 mm x 27 mm	72 mm x 123 mm x 35 mm	76 mm x 120 mm x 42 mm

**More products refer to Industrial Remote I/O Products Catalog**

- RS-485 Remote I/O Modules
- Ethernet Remote I/O Modules
- CAN bus Remote I/O Modules
- PROFIBUS Remote I/O Module

Or refer to <http://www.icpdas.com/root/support/catalog/catalog.html>



## Features:

### 1. Power over Ethernet (PoE)

The PET-7000/PET-7200 series module can be powered by an IEEE802.3af compliant PoE switch. Both Ethernet and power can be carried by an Ethernet cable eliminating the need for additional wiring and power supply.



### 2. Daisy-Chain Ethernet Cabling

The ET-7200/PET-7200 Series has a built-in two-Port Ethernet switch to implement daisy-chain topology. The cabling is much easier and total costs of cable and switch are significantly reduced.

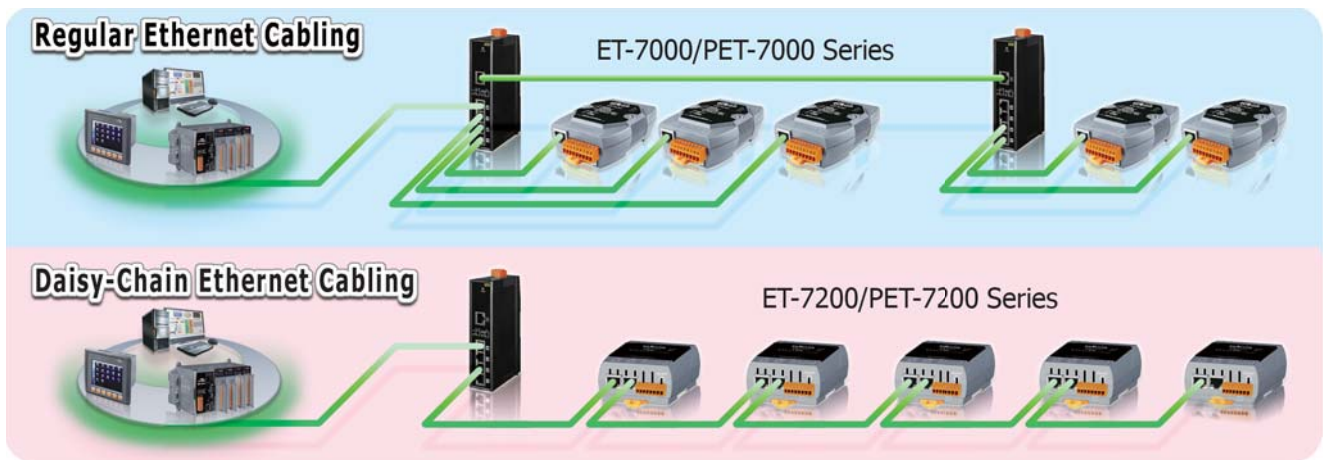

### 3. LAN Bypass

LAN Bypass feature guarantees the Ethernet communication. It will automatically active to continue the network traffic when the ET-7200/PET-7200 loses its power.



### 4. Communication Security

Account and password are needed when logging into the web server. An IP address filter is also included, which can be used to allow or deny connections with specific IP addresses.

### 5. Support for both Modbus TCP and Modbus UDP Protocols

The Modbus TCP, Modbus UDP slave function on the Ethernet port can be used to provide data to remote SCADA software.

### 6. Built-in I/O

Various I/O components are mixed with multiple channels in a single I/O module, which provides the most cost effective I/O usage and enhances performance of the I/O operations.

### 7. Dual Watchdog

The Dual Watchdog consists of a Module Watchdog and a Communication Watchdog. The action of AO,DO are also associated to the Dual Watchdog.

**Module Watchdog** is a built-in hardware circuit to monitor the operation of the module and will reset the CPU if a failure occurs in the hardware or the software. Then the Power-on Value of AO,DO will be loaded.

**Communication Watchdog** is a software function to monitor the communication between the host and the I/O module. The timeout of the communication Watchdog is programmable, when the I/O doesn't receive commands from the host for a while, the watchdog forces the AO,DO to pre-programmed Safe Value to prevent unpredictable damage of the connected devices.



### 8. Highly Reliable Under Harsh Environment

- Wide Operating Temperature Range: -25 ~ +75°C
- Storage Temperature: -30 ~ +80°C
- Humidity 10 ~ 90% RH (Non-condensing)



### 10. I/O Pair Connection

This function is used to create a AI/DI to AO/DO pair through the Ethernet. Once the configuration is completed, the I/O module can poll the status of remote AI/DI devices and then use the Modbus TCP protocol to continuously write to a local AO/DO channels in the background.

### 11. Web HMI

The Web HMI function allows the users to create dynamic and attractive web pages to monitor and control the I/O points. Users can upload specific I/O layout pictures (bmp, jpg, gif format) and define a description for each I/O point. No HTML or Java skills are needed to create the web pages.

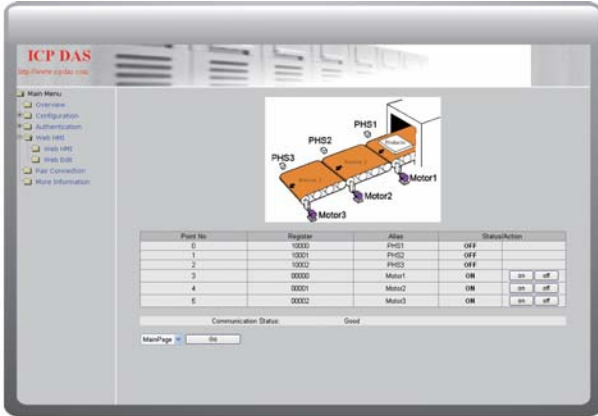

### 13. Dimensions (Units: mm)

ET-7000/PET-7000 Series

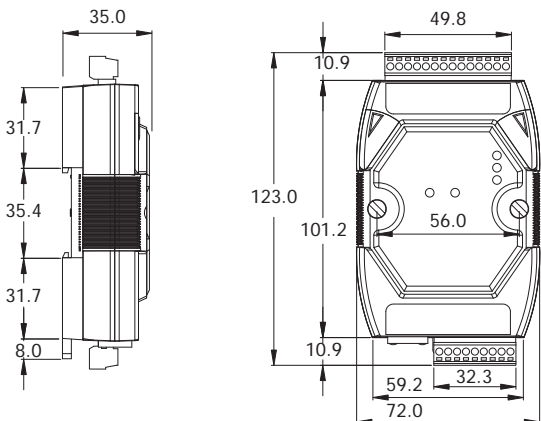

ET-7200/PET-7200 Series

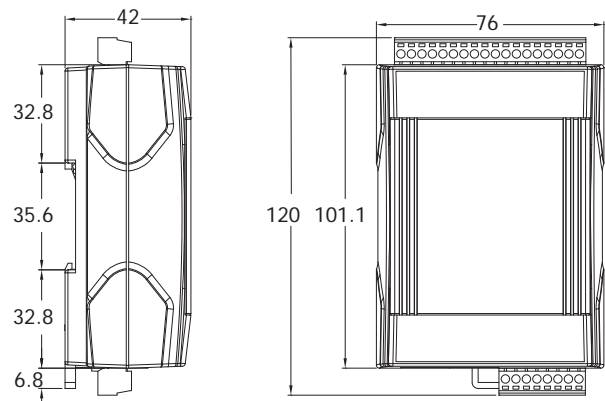

### 9. Power-on Value and Safe Value

Besides setting by the set AO,DO commands, the AO,DO can be set under two other conditions.

**Power-on Value:** The Power-on Value is loaded into the AO,DO under 3 conditions: Power-on, reset by Module Watchdog, reset by reset command.

**Safe Value:** When the Communication Watchdog is enabled and a Communication Watchdog timeout occurs, the "safe value" is loaded into the AO,DO.

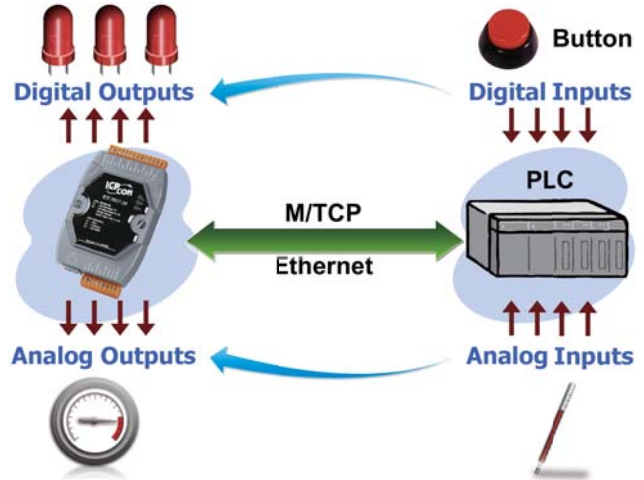

### 12. Built-in Web Server

Each I/O module has a Built-in web server that allows the users to easily configure, monitor and control the module from a remote location using a regular web browser.





## Selection Guide



### Analog Input Model



Model Name		AI			DO		
		Channel	Voltage and Current Input	Sensor Input	Channel	Type	Sink/Source
ET-7005 PET-7005	-	8	-	Thermistor	4	Open Collector	Sink
ET-7015 PET-7015	ET-7215 PET-7215	7	-	RTD: Pt100, Pt1000, Ni120, Cu100, Cu1000	-	-	-
ET-7017 PET-7017	ET-7217 PET-7217	8	$\pm 150$ mV, $\pm 500$ mV, $\pm 1$ V, $\pm 5$ V, $\pm 10$ V, $\pm 20$ mA, $0 \sim 20$ mA, $4 \sim 20$ mA	-	4	Open Collector	Sink
ET-7017-10 PET-7017-10	ET-7217-10 PET-7217-10	10/20	-	-	-	-	-
ET-7018Z PET-7018Z	ET-7218Z PET-7218Z	10	$\pm 15$ mV, $\pm 50$ mV, $\pm 100$ mV, $\pm 500$ mV, $\pm 1$ V, $\pm 2.5$ V $\pm 20$ mA, $0 \sim 20$ mA, $4 \sim 20$ mA	Thermocouple: J, K, T, E, R, S, B, N, C, L, M, and LDIN43710	6/3 (Note 2)	Open Collector	Sink
ET-7019 PET-7019	-	8	$\pm 15$ mV, $\pm 50$ mV, $\pm 100$ mV, $\pm 150$ mV, $\pm 500$ mV, $\pm 1$ V, $\pm 5$ V, $\pm 10$ V	Thermocouple: J, K, T, E, R, S, B, N, C, L, M, and LDIN43710	4	Open Collector	Sink
ET-7019Z PET-7019Z	ET-7219Z PET-7219Z	10	$\pm 20$ mA, $0 \sim 20$ mA, $4 \sim 20$ mA	-	6/3 (Note 2)	-	-

**Note 1:** We recommend to choose ET-7018Z/PET-7018Z and ET-7019Z/PET-7019Z for extremely accurate thermocouple measurement.

**Note 2:** 6 DO channels for ET-7018Z, PET-7018Z, ET-7019Z and PET-7019Z.  
3 DO channels for ET-7218Z, PET-7218Z, ET-7219Z and PET-7219Z.



### Multi-function I/O



Model Name		AI			AO		DI/Counter		DO	
		Channel	Voltage and Current Input	Sensor Input	Channel	Voltage and Current Output	Channel	Contact	Channel	Type
ET-7002 PET-7002	ET-7202 PET-7202	3	$\pm 150$ mV, $\pm 500$ mV, $\pm 1$ V, $\pm 5$ V, $\pm 10$ V, $0 \sim 20$ mA, $\pm 20$ mA, $4 \sim 20$ mA	-	-	-	6	Wet (Sink, Source)	3	Power Relay (Form A)
-	ET-7204 PET-7204	4	-	-	4	$0 \sim 5$ V, $\pm 5$ V, $0 \sim 10$ V, $\pm 10$ V, $0 \sim 20$ mA, $4 \sim 20$ mA	4	Dry (Source), Wet (Sink, Source)	-	-
ET-7016 PET-7016	-	2	$\pm 15$ mV, $\pm 50$ mV, $\pm 100$ mV, $\pm 500$ mV, $\pm 1$ V, $\pm 2.5$ V, $0 \sim 20$ mA, $\pm 20$ mA, $4 \sim 20$ mA	Strain Gauge, Load Cell, Full-Bridge, Half-Bridge, Quarter-Bridge	1 (Note)	$0 \sim 10$ V	2	Wet (Sink, Source)	2	Open Collector (Sink)
ET-7024 PET-7024	ET-7224 PET-7224	-	-	-	4	$0 \sim 5$ V, $\pm 5$ V, $0 \sim 10$ V, $\pm 10$ V, $0 \sim 20$ mA, $4 \sim 20$ mA	5	Dry (Source), Wet (Sink, Source)	5	Open Collector (Sink)
ET-7026 PET-7026	ET-7226 PET-7226	6	$\pm 150$ mV, $\pm 500$ mV, $\pm 1$ V, $\pm 5$ V, $\pm 10$ V, $0 \sim 20$ mA, $\pm 20$ mA, $4 \sim 20$ mA	-	2	-	2	-	2	-

**Note:** The AO is configured as a voltage excitation source for the strain gauge.



### Analog Output



Model Name		AO					
		Resolution	Channel	Voltage Output	Current Output	Safe Value	Power-on Value
ET-7028 PET-7028	ET-7228 PET-7228	12-bit	8	$-0 \sim 5$ V, $\pm 5$ V, $0 \sim 10$ V, $\pm 10$ V	$0 \sim 20$ mA, $4 \sim 20$ mA	Yes	Yes

### ✓ DC Digital I/O



Model Name		DI/Counter			DO			
		Channel	Contact	Sink/Source	Channel	Type	Sink/Source	Max. Load Current @ 25°C
ET-7042 PET-7042	ET-7242 PET-7242	-	-	-	16	Open Collector	Sink	100 mA/channel
ET-7044 PET-7044	ET-7244 PET-7244	8	Wet	Sink, Source	8	Open Collector	Sink	300 mA/channel
ET-7050 PET-7050	-	12	Wet	Sink, Source	6	Open Collector	Sink	100 mA/channel
ET-7051 PET-7051	ET-7251 PET-7251	16	Wet	Sink, Source	-	-	-	-
ET-7052 PET-7052	ET-7252 PET-7252	8	Wet	Sink, Source	8	Open Collector	Source	650 mA/channel
ET-7053 PET-7053	ET-7253 PET-7253	16	Dry	Source	-	-	-	-
-	ET-7255 PET-7255	8	Dry, Wet	Sink, Source	8	Open Collector	Source	650 mA/channel

### ✓ AC Digital Input



Model Name		DI/Counter		
		Channel	Contact	Sink/Source
-	ET-7258 PET-7258	16	Wet	Sink, Source
-	ET-7259 PET-7259	16	Wet	Sink, Source

### ✓ Relay Output & Digital Input



Model Name		Relay Output				DI/Counter		
		Channel	Relay	Type	Max. Load Current @ 25°C	Channel	Contact	Sink/Source
ET-7060 PET-7060	ET-7260 PET-7260	6	Power Relay	Form A (SPST N.O.)	5.0 A/channel	6	Wet	Sink, Source
-	ET-7261 PET-7261	11	Power Relay	Form A (SPST N.O.)	5.0 A/channel	-	-	-
ET-7065 PET-7065	-	6	PhotoMOS Relay	Form A	1.0 A/channel	6	Wet	Sink, Source
ET-7066 PET-7066	-	8	PhotoMOS Relay	Form A	1.0 A/channel	-	-	-
ET-7067 PET-7067	ET-7267 PET-7267	8	Power Relay	Form A (SPST N.O.)	5.0 A/channel	-	-	-

### ✓ Encoder/Counter Input



Model Name		Axis	Counter	Counting Mode	Input Level	Counter Value Retention
ET-7083 PET-7083	-	3	32-bit	Quadrant: 1 MHz Max. CW/CCW: 4 MHz Max. Pulse/Direction: 4 MHz Max.	5 V, 12 V, 24 V	Yes, up to 10 years

### 3.9 MQTT I/O Module

MQ-7200M is an I/O module designed for Internet of Things. It support MQTT V3.1 client. Through the MQTT broker (can be installed on private cloud or public cloud), it can flexibly exchange data between I/O modules and other MQTT clients.

Compared to request/response type of Ethernet I/O modules, MQTT I/O modules bring two obvious benefits:

**1. Reduce the Ethernet communication packets**

The behavior of most request/response type of Ethernet I/O modules is: the master polls every modules periodically no matter the data is changed or not. MQTT I/O modules can be configured to publish data to the broker periodically or an event happens. Thus the Ethernet communication packets can be obviously reduced.

**2. Simplify the network configuration**

MQTT I/O modules can be configured as dynamic IP address. Only the MQTT broker needs a domain name or a static IP address. Thus the networking configuration for each MQTT I/O module can be the same. Thus the configuring work becomes simplified.

**Features:**

- Support MQTT V3.1 Client
- Built-in Web Server for Configuration
- 2-port Ethernet Switch for Daisy-chain Topology
- LAN Bypass to Prevent Communication Lost While Power Lost
- Build-in LED indicators for I/O

**Appearance:**

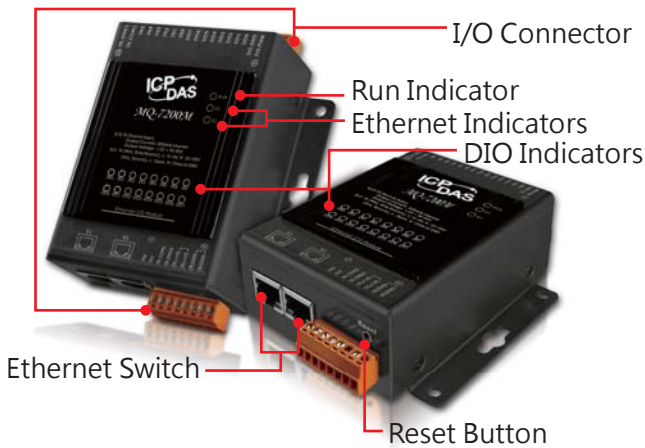

**Applications:**

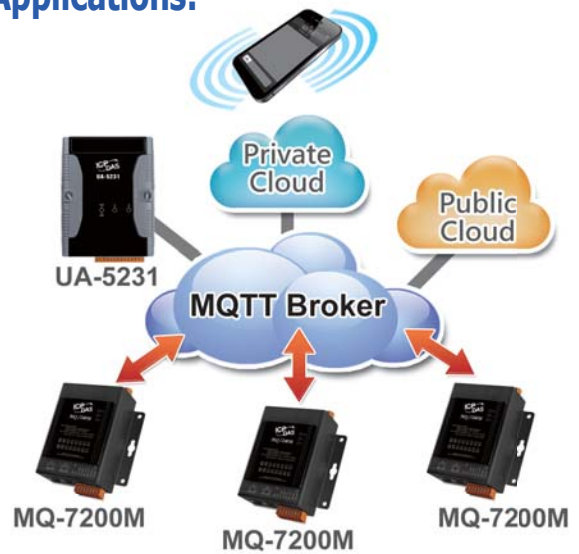

**Selection Guide**

Module Name	DI			DO			
	Channel	Type	Sink/Source	Channel	Type	Sink/Source	Max. Load
MQ-7244M	8	Wet	Sink/Source	8	Open Collector	Sink	300 mA/Channel
MQ-7251M	16	Wet	Sink/Source	-	-	-	-
MQ-7252M	8	Wet	Sink/Source	8	Open Collector	Source	650 mA/Channel
MQ-7253M	16	Dry	Source	-	-	-	-
MQ-7255M	8	Dry, Wet	Source	8	Open Collector	Source	650 mA/Channel
MQ-7258M	16	AC	Sink/Source	-	-	-	-

## 3.10 Wi-Fi Products

WLAN (Wireless Local Area Network) links devices by wireless distribution method (spread-spectrum or OFDM radio), and generally provides a connection through an access point to the Internet. WLAN allows users to move device within a local coverage area, and still be connected to the network. High-bandwidth allocation for wireless will make a relatively low-cost wiring possible. Nowadays, Wireless LAN applications are very popular. They're not only faster than traditional industrial transmissions, i.e. RS-232, RS-485, RS-422 etc, but are also able to minimize the need for troublesome wiring tasks and have a higher mobility than an Ethernet network. ICP DAS provides a great variety of WLAN products, which are all compliant with standard of IEEE 802.11.

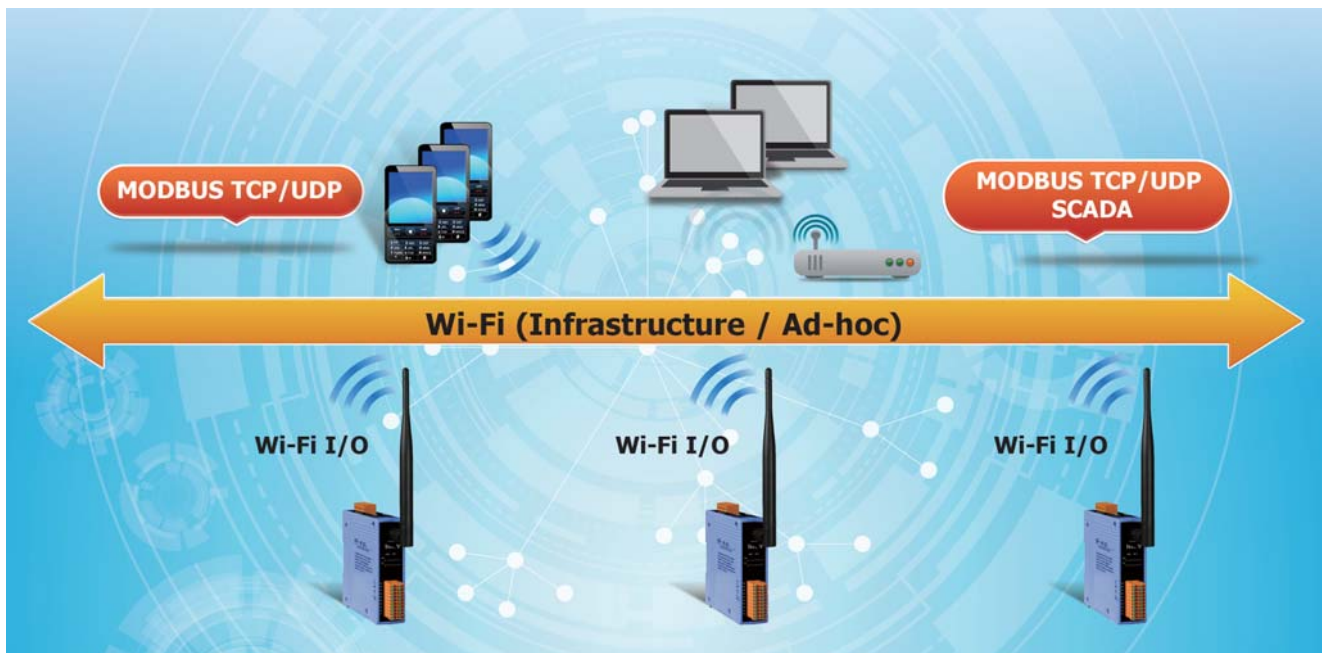

### Advantages & Benefits:

- Build a wireless network via Wi-Fi technology. There is no need to build an expansive fixed line network
- Enable CAN/Serial/Ethernet device to be connected to the same network via Wi-Fi without any cable
- Use widely available IEEE 802.11 (Wi-Fi) or Ethernet network infrastructure
- Support IEEE 802.11 b/g for Wi-Fi Ad Hoc mode
- Secure data access with WEP, WPA, WPA2



### Selection Guide

Module Name	Description
<b>Remote Maintenance</b>	M2M-711D Remote Maintenance Wi-Fi Device Terminal Unit
<b>Wi-Fi Converter</b>	I-7540D-WF CAN to Wi-Fi Converter
<b>Wi-Fi Bridge</b>	WF-2571 Ethernet to Wi-Fi Bridge
<b>Wi-Fi Gateway</b>	RMV-760D-MTCP Modbus TCP/RTU Data-Exchange with Wi-Fi Interface Gateway
<b>Wi-Fi I/O Module</b>	WF-2015 Wi-Fi I/O Module (6-ch RTD Input)
	WF-2017 Wi-Fi I/O Module (8-ch Differential/16-ch Single-Ended AI)
	WF-2019 Wi-Fi I/O Module (10-ch Universal AI)
	WF-2026 Wi-Fi I/O Module (5-ch AI / 2-ch AO / 2-ch DI / 3-ch DO)
	WF-2042 Wi-Fi I/O Module (16-ch DO)
	WF-2051 Wi-Fi I/O Module (16-ch DI)
	WF-2055 Wi-Fi I/O Module (8-ch DI / 8-ch DO)
	WF-2060 Wi-Fi I/O Module (6-ch DI / 6-ch Relay)
WFM-R14 Wi-Fi I/O Module with Metal Case (14-ch Relay)	

## Wi-Fi Converter

### CAN to Wi-Fi Converter

#### I-7540D-WF

The I-7540D-WF supports the wireless transmission of CAN data between a CAN network and a WLAN network according to the 802.11b/g standard. It provides CAN to WLAN converter functionality together with wireless transparent transmission on the CAN network.

- IEEE 802.11b/g compliant
- CAN 2.0A/2.0B compliant
- Point to point or point to multi-points connection via wireless LAN
- Connect CAN networks via a WLAN bridge
- Communication efficiency: one-way is up to 700 fps; two-way 350 fps.
- Wireless transmission distance: up to 100 meters
- Two different operation modes: infrastructure and ad-hoc
- Supports WEP, WPA and WPA2 encryption for wireless LAN

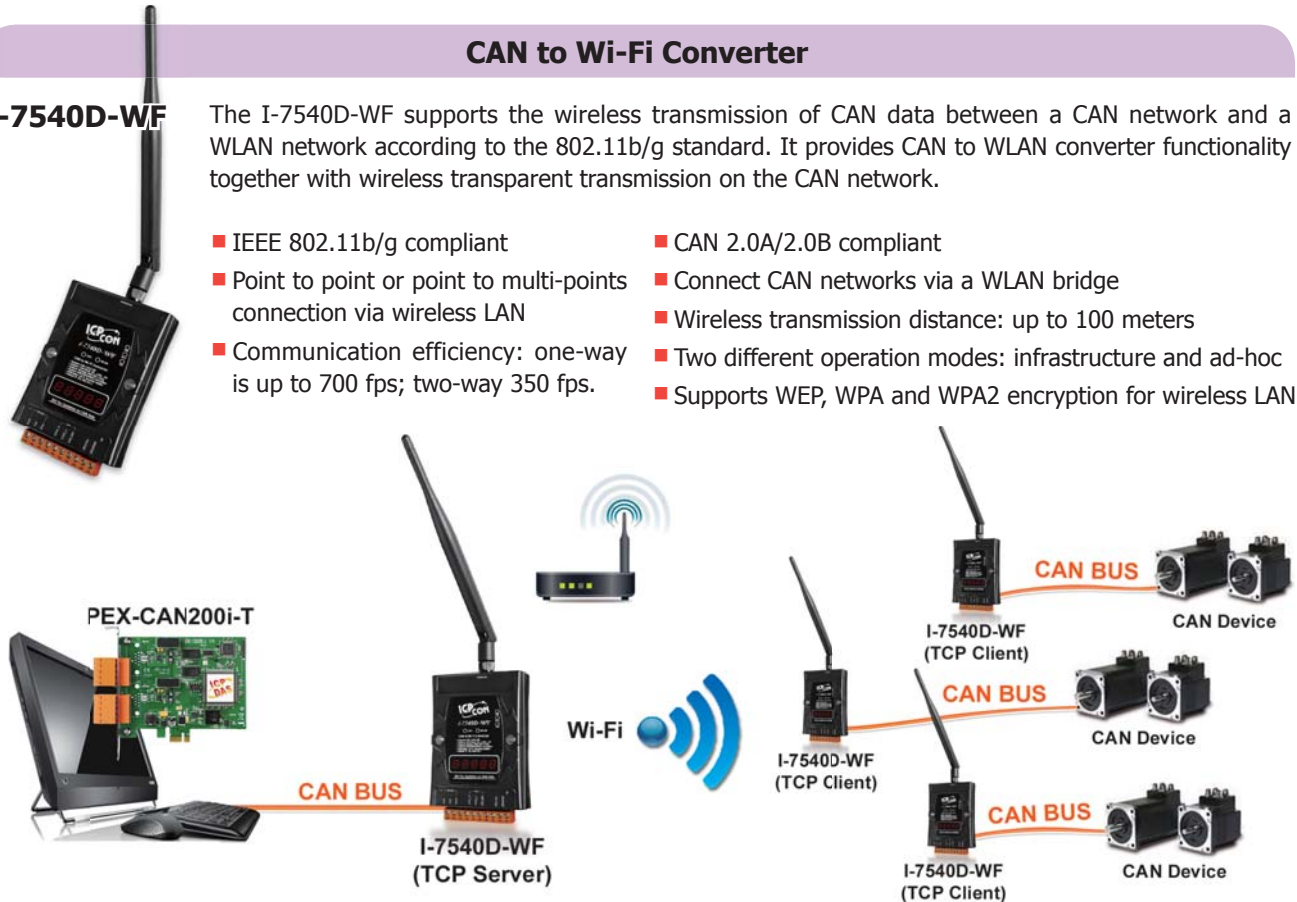

## Wi-Fi Bridge

### Ethernet to Wi-Fi Bridge

#### WF-2571

The WF-2571 is an Industrial Ethernet to Wi-Fi Bridge that creates a connection between an 802.11b/g wireless LAN and a device with a standard Ethernet port. The Bridge transparently conveys data between devices with a 100Base-TX Ethernet interface and a wireless LAN without drivers or complicated addressing schemes. This significantly reduces the complexity of network connectivity and wireless system deployment and also provides wireless LAN and Internet connectivity to industrial, scientific and automotive applications.

- Compatible with IEEE 802.11b/g standards
- USB-based configuration
- Supports both Infrastructure and Ad-hoc mode
- No driver installation required
- Plug-and-Play Ethernet to Wi-Fi connectivity
- Enterprise Class wireless security (WEP, WPA and WPA2)

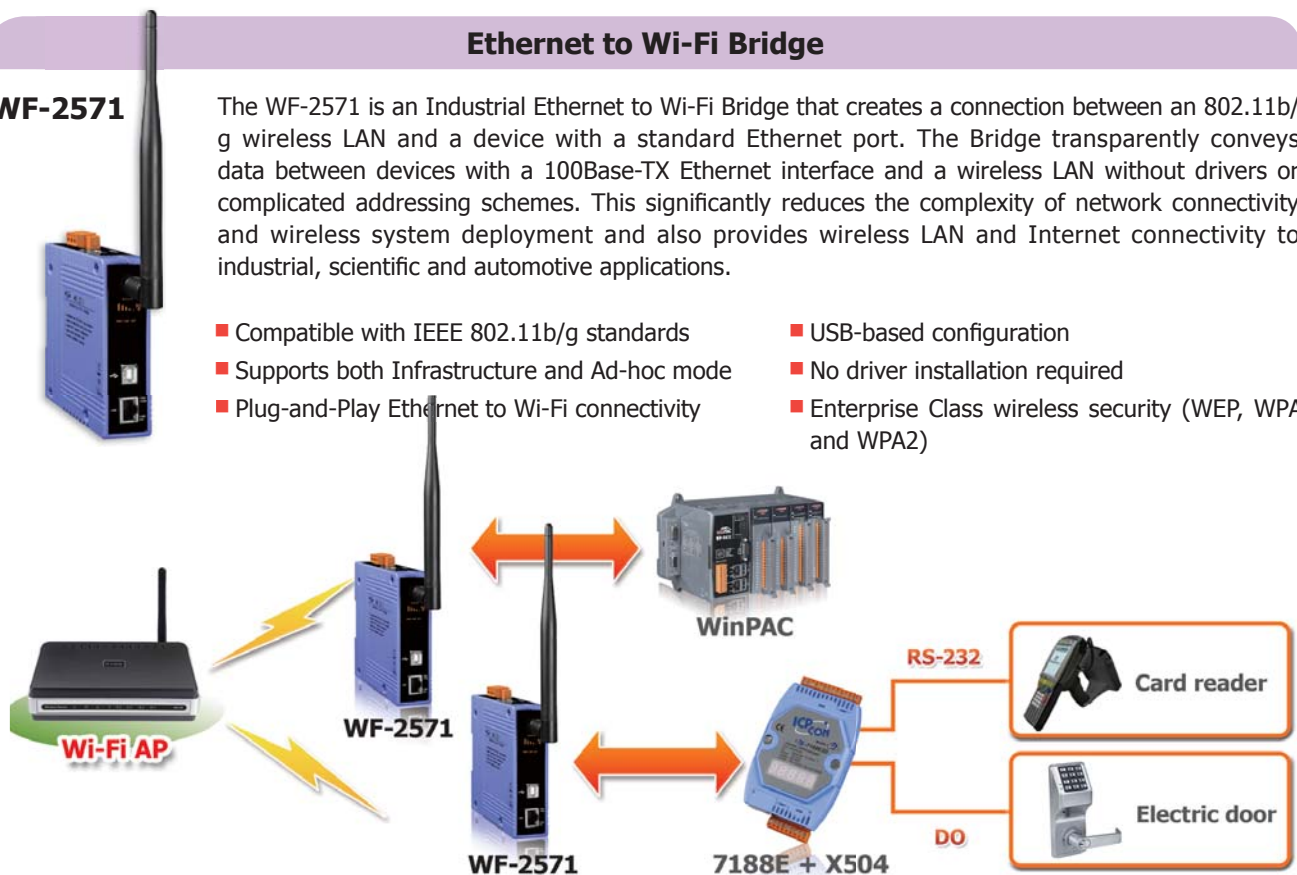

## WLAN Remote Maintenance Device

### Remote maintenance Wi-Fi Device Terminal Unit

#### M2M-711D

The M2M-711D module is specially designed for the remote maintenance and upgrading the serial to network application solution. It is suitable for the harsh industrial field. M2M-711D provides 2 major technologies on networking: VxServer and Pair-connection. This solution can transfer the site condition of equipment accurately. The maintenance engineer can directly check and diagnose the device/PLC like on-site. This can reduce the huge maintenance cost to increase the competition of enterprises.

- IEEE 802.11b/g compliant
- Support VxServer software
- 5-Digit 7 Segment LED Display
- Web-based administration
- Supports both Infrastructure and Ad-hoc mode
- Provide pair connection (RS-232,RS-485) on network
- Support Server and Client communication mode
- Supports WEP-64,WEP-128, WPA-TKIP and WPA2-AES encryption

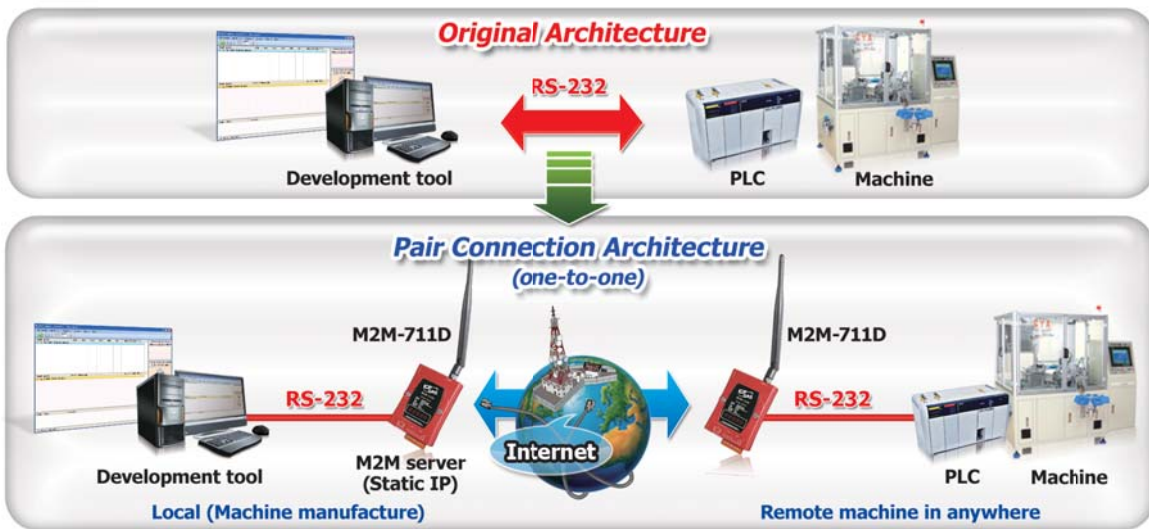

## Wi-Fi Gateway

NEW

### Modbus TCP/RTU Data-Exchange with Wi-Fi Interface Gateway

#### RMV-760D-MTCP

RMV-760D-TCP is a Modbus TCP/RTU gateway. It exchanges Modbus command from Modbus TCP/RTU master to Modbus RTU/TCP slave. Modbus TCP command can be transferred by not only Ethernet port but also Wi-Fi interface. It supports VxComm and Pair-Connection functions. Users can choose Ethernet mode or Wi-Fi mode to do the pair connection, which provides TCP data tunneling between two serial devices.



- IEEE 802.11b/g compliant
- 5-Digit 7 Segment LED Display
- Supports Virtual COM applications
- Supports pair-connection applications
- Supports both Infrastructure and Ad-hoc mode
- Supports WEP-64,WEP-128, WPA-TKIP and WPA2-AES encryption
- Application Modes: Virtual COM, MB TCP Server/Client, MB RTU Master/Slave





## Wi-Fi I/O Modules

The WF-2000 series I/O modules in WLAN connection complies with the IEEE 802.11b/g standards. They make an easy way to incorporate wireless connectivity into monitoring and control systems. Wi-Fi I/O modules support Modbus TCP/UDP protocol and network encryption configuration, which makes perfect integration to SCADA software and offer easy and safe access for users from anytime and anywhere.

Model Name	WF-2026	WF-2042	WF-2055	WF-2060	WF-2051	WFM-R14	
<b>Digital Inputs</b>							
Channels	2	-	8	6	16	-	
Input Type	Dry Contact: Source		Dry Contact: Source Wet Contact: Sink / Source				
Counters	Channels		2	8	6		16
	Max. Counts		32-bit	32-bit			
	Max. Input Freq.		10K Hz	8K Hz			
Photo-Isolation	3750 Vrms	3750 Vrms					
<b>Digital Output</b>							
Channels	3	16	8	6	-	14	
Type	Sink(NPN)			Form A		2 Form A/ 12 Form C	
Load Voltage	+3.5 VDC ~ +50 VDC			30 VDC/250 VAC		30 VDC/ 250 VAC	
Load Current	700mA/channel			5A/channel		5A(Form A)/ 6A(Form C)	
Intra-module Isolation	3750 VDC			-		-	
Overvoltage Protection	60 VDC			-	-		
<b>Mechanical</b>							
Casing	Plastic					Metal	

Model Name	WF-2026	WF-2017	WF-2019	WF-2015
<b>Analog Input</b>				
Channels	5 (Diff)	8 (Diff) / 16 (SE)	10 (Diff)	6
Input Type	Voltage	±150 mVDC, ±500 mVDC, ±1 VDC, ±5 VDC, ±10 VDC	±150 mV, ±500 mV, ±1 V, ±5 V, ±10 V	±15 mV, ±50 mV, ±100 mV, ±500 mV, ±1 V, ±2.5V, ±5V, ±10V
	Current	0 ~ +20 mA, +4 ~ +20 mA, ±20 mA (Jumper Selectable)	0 ~ +20 mA, +4 ~ +20 mA, ±20 mA (Jumper Selectable)	±20 mA (External resistor required)
	Thermocouple			J, K, T, E, R, S, B, N, C
	2/3-wire RTD	-		Pt100, Pt1000, Ni120, Cu50, Cu100, Cu1000
Resolution	16 bit			
Accuracy	±0.1% FSR			±0.05% FSR
Sampling Rate	10 Hz (Total)			12 Hz (Total)
Overvoltage Protection	240 Vrms	Diff	240 Vrms	240 Vrms
		SE	150 Vrms	
<b>Analog Output</b>				
Channels	2			
Output Type	Voltage	+0 ~ +5 VDC, +0 ~ +10 VDC, ±5 VDC, ±10 VDC		
	Current	+0 ~ +20 mA, +4 ~ +20 mA (Jumper Selectable)		
Resolution	12 bit			
Accuracy	±0.1% FSR			
Output Capacity	10 VDC @ 20 mA			
<b>Mechanical</b>				
Casing	Plastic			

<b>Wireless Communication</b>	
Standard Supported	IEEE 802.11b/g
Wireless Mode	Infrastructure & Ad-hoc
Encryption	WEP, WPA and WPA2
<b>Power</b>	
Input Voltage Range	10 VDC ~ 30 VDC
Operating Temperature	-25 ~ +75°C



# CAN Bus Products



<b>4.1</b>	<b>Overview</b>	<b>P 4-1</b>
<b>4.2</b>	<b>CAN Bus Repeater/Bridge/Switch</b>	<b>P 4-4</b>
<b>4.3</b>	<b>CAN Converters</b>	<b>P 4-7</b>
	<ul style="list-style-type: none"> <li>4.3.1 USB to CAN Converters - - - - - P 4-7</li> <li>4.3.2 CAN to Fiber Converter/Bridge- - - - - P 4-11</li> <li>4.3.3 Ethernet/Wi-Fi to CAN Converters- - - - - P 4-15</li> <li>4.3.4 Uart to CAN Converters - - - - - P 4-20</li> </ul>	
<b>4.4</b>	<b>Gateway/ Protocol Converters</b>	<b>P 4-25</b>
	<ul style="list-style-type: none"> <li>4.4.1 CANopen Gateways- - - - - P 4-25</li> <li>4.4.2 CANopen Motion Solution - - - - - P 4-28</li> <li>4.4.3 DeviceNet Gateways - - - - - P 4-29</li> <li>4.4.4 J1939 Gateways - - - - - P 4-32</li> </ul>	
<b>4.5</b>	<b>Palm-size Programmable CAN Controllers</b>	<b>P 4-35</b>
<b>4.6</b>	<b>PC-based CAN Bus Boards</b>	<b>P 4-36</b>
<b>4.7</b>	<b>PAC-based CAN Modules</b>	<b>P 4-41</b>
<b>4.8</b>	<b>CAN Bus Power Meter</b>	<b>P 4-42</b>
<b>4.9</b>	<b>CAN Bus Data Logger</b>	<b>P 4-44</b>
<b>4.10</b>	<b>I/O Modules and Units</b>	<b>P 4-46</b>
	<ul style="list-style-type: none"> <li>4.10.1 Analog Input Modules - - - - - P 4-48</li> <li>4.10.2 Analog Output Modules - - - - - P 4-49</li> <li>4.10.3 Digital I/O Modules - - - - - P 4-50</li> <li>4.10.4 CANopen I/O Units - - - - - P 4-51</li> <li>4.10.5 DeviceNet I/O Units- - - - - P 4-52</li> <li>4.10.6 I/O Modules Support List of CAN-8000 Units - - - - - P 4-53</li> </ul>	
<b>4.11</b>	<b>CANcheck</b>	<b>P 4-54</b>
<b>4.12</b>	<b>Case Studies</b>	<b>P 4-56</b>



## 4.1 Overview

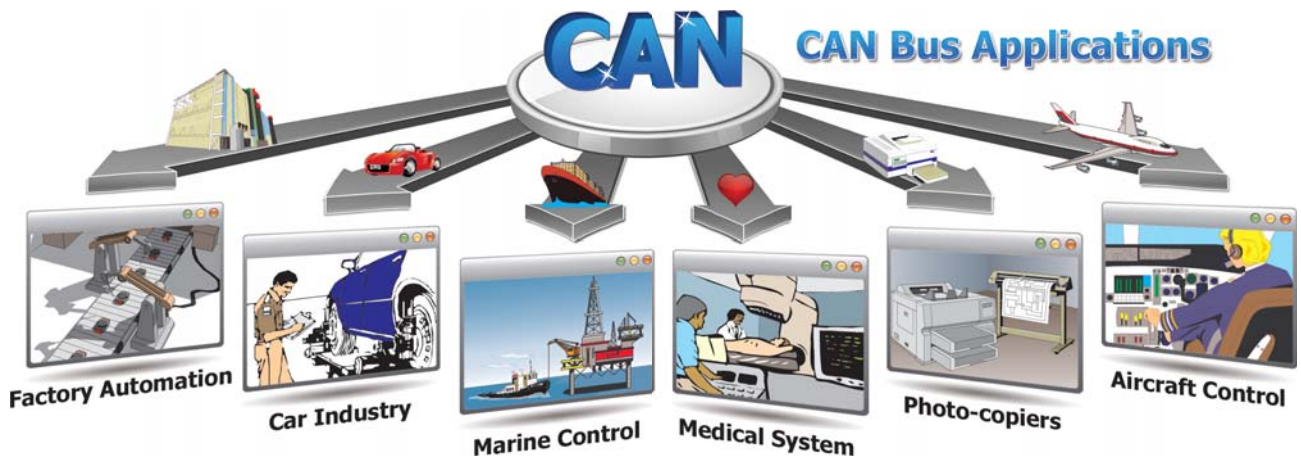

4

CAN Bus

ICP DAS has been developing rich **CAN-based/DeviceNet/CANopen/J1939** products for more than 10 years, including PCI interface cards, Fieldbus converters, PACs, gateways and remote I/O modules. We provide complete hardware solutions to satisfy a wide variety of CAN-based applications that can effectively solve issues related of data acquisition and calculation, transmission distance extension, network topology limitations, communication interface transformation, and noise resistance. In addition, ICP DAS supplies a large ranges of software resource, such as utility tools, APIs, demo programs, OPC, ActiveX and third-party drivers, which can help users to develop complex custom control and monitoring systems more easily and quickly. For certain special applications, we can offer flexible OEM/ODM projects to match the different requirements of our customers. Through ICP DAS's efficient and reliable service, you can easily complete your complex CAN-based projects.

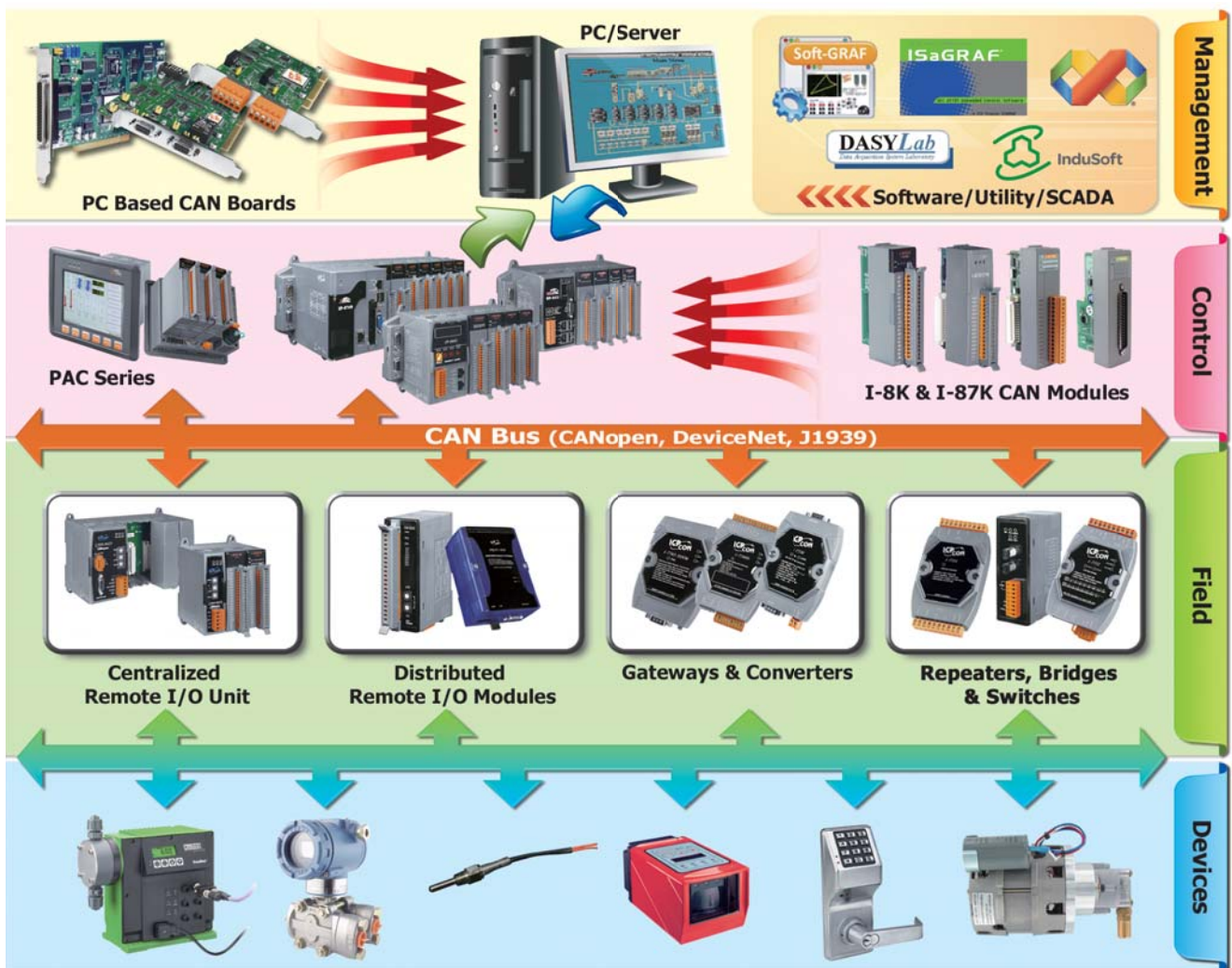



## Selection Guide

Model Name		Description		
<b>CAN Bus Repeater/ Bridge/Switch (Ch 4.2)</b>	I-7531	Isolated CAN Bus Repeater		
	I-7532	Isolated Two-channel CAN Bus Bridge		
	I-2534	4-Port CAN Bus Switch		
	I-5534-M	4-Port CAN Bus Switch with Metal Casing		
<b>CAN Converter (Ch 4.3)</b>	USB to CAN Converter	I-7565	1-Port Cost Effective USB to CAN Converter	
		I-7565-H1/H2	1/2-Port High Performance USB to CAN Converter	
		I-7565-CPM	Intelligent USB to CANopen Converter	
		I-7565-DNM	Intelligent USB to DeviceNet Converter	
	CAN to Fiber Converter/ Bridge	I-2532	CAN to Multi-mode Fiber Converter	
		I-2533	CAN to Multi-mode Bridge	
		I-2533CS	CAN to Single-mode Fiber Bridge	
		I-2533CS-60	CAN to Single-mode Fiber Bridge	
		I-2533CS-A/I-2533CS-B	CAN to Single-mode Fiber Bridge with 1-port SC Fiber connector	
	Ethernet/ Wi-Fi to CAN Converter	I-7540D-MTCP	Modbus TCP to CAN Converter	
		ECAN-240	Modbus TCP Client/Server to two CAN ports Converter	
		I-7540D	Ethernet to CAN Converter	
		I-7540D-WF	Wi-Fi to CAN Converter	
	Uart to CAN converter	I-7530-FT	RS-232 to Fault-Tolerance CAN Converter	
		I-7530	RS-232 to CAN Converter	
		tM-7530	Tiny RS-232 to CAN Converter	
		I-7530A	RS-232/422/485 to CAN Converter	
		I-7530A-MR	Modbus RTU to CAN Converter	
	<b>Gateway/ Protocol Converter (Ch 4.4)</b>	CANopen Gateway	I-7232D	CANopen Slave to Modbus RTU Master Gateway
			GW-7433D	Modbus TCP/RTU Slave to CANopen Master Gateway
DeviceNet Gateway		I-7242D	DeviceNet Slave to Modbus RTU Master Gateway	
		GW-7243D	DeviceNet Slave to Modbus TCP/RTU Master Gateway	
		GW-7434D	Modbus TCP/RTU Slave to DeviceNet Master Gateway	
J1939 Gateway		GW-7228	Modbus RTU Slave to J1939 Master Gateway	
		GW-7238D	Modbus TCP/RTU Slave to J1939 Master Gateway	
<b>Palm-size Programmable CAN Controller (Ch 4.5)</b>	I-7188XBD-CAN	1-Port programmable CAN controller with RS-232/485		
	uPAC-7186EXD-CAN	1-Port programmable CAN controller with Ethernet and RS-232/485		
	uPAC-5001D-CAN2	2-Port programmable CAN controller with Ethernet and RS-232/485		
<b>PC-based CAN Bus Boards (Ch 4.6)</b>	PEX-CAN200i	2-Port PCI Express CAN Communication Board		
	PISO-CAN100U	1-Port Universal PCI CAN Communication Board		
	PISO-CAN200U	2-Port Universal PCI CAN Communication Board		
	PISO-CAN400U	4-Port Universal PCI CAN Communication Board		
	PISO-CAN800U	8-Port Universal PCI CAN Communication Board		
	PCM-CAN100	1-Port PCI-104 CAN Communication Module		
	PCM-CAN200	2-Port PCI-104 CAN Communication Module		
	PCM-CAN200P	2-Port PCI-104 + CAN Communication Module		



## Selection Guide

### 4

### CAN Bus

Model Name		Description		
<b>PC-based CAN Bus Boards (Ch 4.6)</b>	PISO-CM100U	1-Port Universal PCI CAN Board with Built-in Programmable CPU		
	PISO-CM200U	2-Port Universal PCI CAN Board with Built-in Programmable CPU		
	PCM-CM100	1-Port PCI-104 CAN Board with Built-in Programmable CPU		
	PISO-DNM100U	1-Port Universal PCI CAN Board with Built-in DeviceNet Master Firmware		
	PISO-DNS100U	1-Port Universal PCI CAN Board with Built-in DeviceNet Slave Firmware		
	PISO-CPM100U	1-Port Universal PCI CAN Board with Built-in CANopen Master Firmware		
	PCM-CPM100	1-Port PCI-104 CAN Board with Built-in Programmable CPU		
<b>PAC-based CAN Modules (Ch 4.7)</b>	I-8120W/I-87120	1-Port Intelligent CAN Bus Communication Module		
	I-8123W/I-87123	1-Port High Performance CANopen Master Module		
	I-8124W/I-87124	1-Port High Performance DeviceNet Master Module		
<b>I/O Module and Unit (Ch 4.10)</b>	Analog Input Modules	CAN-2015C	8-Ch RTD Input Module with CANopen Protocol	
		CAN-2015D	8-Ch RTD Input Module with DeviceNet Protocol	
		CAN-2017C	8-Ch AI Module with CANopen Protocol	
		CAN-2017D	8-Ch AI Module with DeviceNet Protocol	
		CAN-2018C	8-Ch Thermocouple Input Module with CANopen Protocol	
		CAN-2018D	8-Ch Thermocouple Input Module with DeviceNet Protocol	
		CAN-2019C	10-Ch AI Module with CANopen Protocol	
		CAN-2019D	10-Ch AI Module with DeviceNet Protocol	
	Analog Output Modules	CAN-2024C	4-Ch AO Module with CANopen Protocol	
		CAN-2024D	4-Ch AO Module with DeviceNet Protocol	
		CAN-2026C	6-Ch AI, 2-Ch AO, 2-Ch DI and 1-Ch DO Module with CANopen Protocol	
		CAN-2026D	6-Ch AI, 2-Ch AO, 2-Ch DI and 1-Ch DO Module with DeviceNet Protocol	
	Digital I/O Modules	CAN-2053C	16-Ch DI Module with CANopen Protocol	
		CAN-2053D	16-Ch DI Module with DeviceNet Protocol	
		CAN-2054C	8-Ch DI, 8-Ch DO(Sink) Module with CANopen Protocol	
		CAN-2054D	8-Ch DI, 8-Ch DO(Sink) Module with DeviceNet Protocol	
		CAN-2055C	8-Ch DI, 8-Ch DO(Source) Module with CANopen Protocol	
		CAN-2055D	8-Ch DI, 8-Ch DO(Source) Module with DeviceNet Protocol	
		CAN-2057C	16-Ch DO Module with CANopen Protocol	
		CAN-2057D	16-Ch DO Module with DeviceNet Protocol	
	CANopen I/O Units	CAN-8x23	CANopen Remote I/O Unit with 1/2/4/8 I/O Slot	
	DeviceNet I/O Units	CAN-8x24	DeviceNet Remote I/O Unit with 1/2/4/8 I/O Slot	
	<b>CAN Specific Device</b>	CAN bus Power Meter	PM-3133-CPS series	3 Phase Compact Smart Meter with CANopen Protocol
			PM-3112-CPS	2 loops single-phase Power Meter with CANopen Protocol
PM-3114-CPS			4 loops single-phase Power Meter with CANopen Protocol	
PM-4324-CPS			Multi-Channel Power Meter with CANopen Protocol	
CAN bus Data Logger		CAN-Logger100	USB to 1-port CAN bus data logger device	
	CAN-Logger200	USB to 2-port CAN bus data logger device		

## 4.2 CAN Bus Repeater/Bridge/Switch

The CAN Bus Repeater/Bridge/Switch is used to enhance the signal quality, extend the communication distance, isolate CAN Bus network. ICP DAS provides following products.

Model Name	I-7531	I-7532	I-2534	I-5534-M
Pictures	Isolated CAN Bus Repeater 	Isolated Two-channel CAN Bus Bridge 	4-Port CAN Bus Switch 	4-Port CAN Bus Switch with Metal Casing 
<b>CAN Interface</b>				
Transceiver	NXP 82C250		NXP TJA1042	
Channel number	2		4	
Connector	3-pin screwed terminal block (CAN_GND, CAN_L, CAN_H)	4-pin screwed terminal block (CAN_GND, CAN_L, CAN_SHLD, CAN_H)	9-pin male D-Sub with CAN_GND, CAN_SHLD, CAN_H, CAN_L	
Transmission speed (bps)	5 k ~ 800 k with auto baud rate detection		5 k ~ 1 M selected by rotary switch or utility tool	
Transmission Distance (m)	Depends on the CAN baud rate		Duplicates the transmission distance depended on the CAN baud rate	
Propagation Delay	Max. 200ns (shortens the transmission distance by ~ 40 m)	Depends on the CAN baud rate (Max. 134 us @ 1 Mbps)	Depends on the CAN baud rate (Max. 440 us @ 1 Mbps)	
Terminator Resistor	Jumper for 120 Ω terminator resistor		DIP switch for the 120 Ω terminator resistor	Jumper for 120 Ω terminator resistor
Isolation	3000 VDC for DC-to-DC, 2500 Vrms for photo-couple			
Specification	ISO 11898-2, CAN 2.0A and CAN 2.0B			
<b>LED</b>				
Round LED	CAN Status LED	PWR LED, Rx LED, ERR LED	PWR LED, CAN1 LED, CAN2 LED, CAN3 LED, CAN4 LED	
<b>Power</b>				
Power supply	Unregulated +10 ~ +30 VDC			
Protection	Power reverse polarity protection, Over-voltage brown-out protection			
Power Consumption	2 W		3 W	
<b>Mechanism</b>				
Installation	DIN-Rail			
Casing	Plastic		Metal	
Dimensions (W x L x H)	72 x 118 x 33 (mm)		32.3 x 99 x 77.5 (mm)	116.5 x 127 x 61.3 (mm)
<b>Environment</b>				
Operating Temperature	-25 ~ +75°C			
Storage Temperature	-30 ~ +80°C			
Relative Humidity	10 ~ 90% RH, Non-condensing			

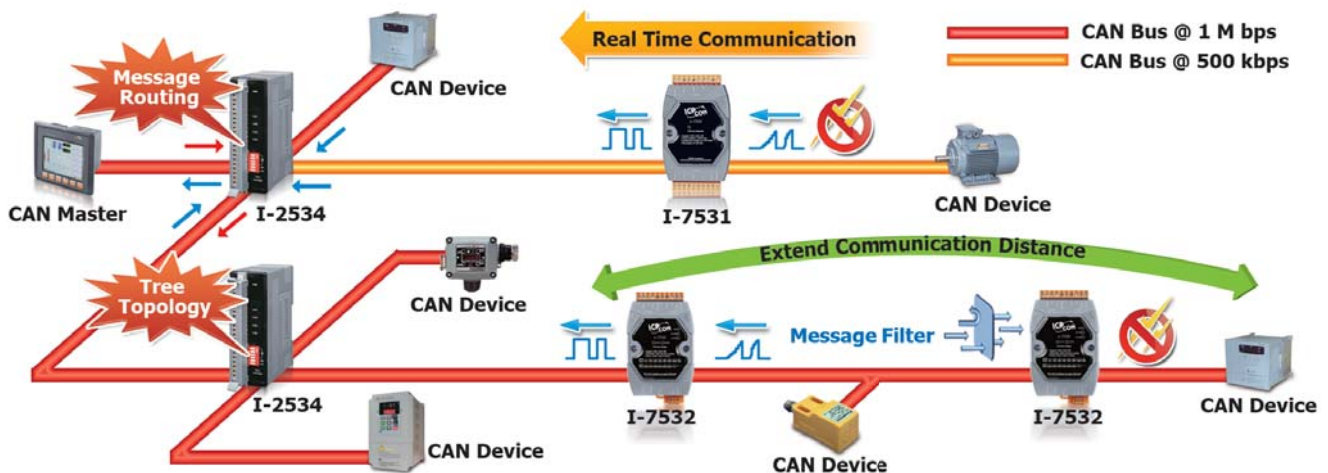

### Isolated CAN Bus Repeater

#### I-7531



The I-7531 is an isolated CAN repeater that can be used to establish a physical coupling of two segments of a CAN bus system. This module is designed to isolate the noise and disturbance between the two CAN ports of the I-7531. When the CAN signal is decayed because of the rough bus cable or noise, the I-7531 can recover the shape of the CAN signals to the original ones. Tree topologies can be implemented as well as long drop lines using the I-7531. In order to use the I-7531 easily, the module can automatically adjust the baud rate by itself to match the CAN network. Users just connect the I-7531 with the CAN buses, check the terminator resistor and power it on, subsequently the I-7531 enable to work normally.

- Automatic baud rate detection
- Up to 100 nodes on each CAN port
- Compatible with CAN specification 2.0 parts A and B
- Fully compatible with the ISO 11898-2 standard
- 2500 Vrms photocoupler isolation on the CAN side
- Jumper for the 120 Ω terminator resistor of the CAN bus
- Supports a wide range of baud rates from 5 kbps ~ 800 kbps
- 3 kV galvanic isolation between the power supply and the two CAN channels

4

CAN Bus



### Isolated two-channel CAN Bus Bridge

#### I-7532



The I-7532 is a CAN bus bridge that can be used to integrate two CAN networks even they implement different CAN baud rate. Compared with the I-7531, the I-7532 offers more than 3 useful features. First, the transmission distance limitation of the CAN bus system on each side of the I-7532 is independent, which means the total CAN network distance can be extended. Second, when some errors (e.g. bit error) happened on one CAN port of the I-7532, the other CAN port of the I-7532 will not be affected and can still work correctly. Last, the baud rate and CAN message filter configuration of these two CAN ports on the I-7532 is able to be tuned following users' applications. These features mean that users can design their applications more flexible and efficient.

- Compatible with CAN specification 2.0 parts A and B
- Supports a range of baud rates from 10 kbps ~ 1 Mbps
- Jumper for the 120 Ω terminator resistor of the CAN bus
- 2500 Vrms photocoupler isolation on the CAN side
- 3 kV galvanic isolation between the two CAN channels
- Fully compatible with the ISO 11898-2 standard
- Two CAN channels
- Extends the CAN transmission distance
- Up to 100 nodes on each CAN port
- Able to configure the CAN baud rate for each channel using a rotary switch

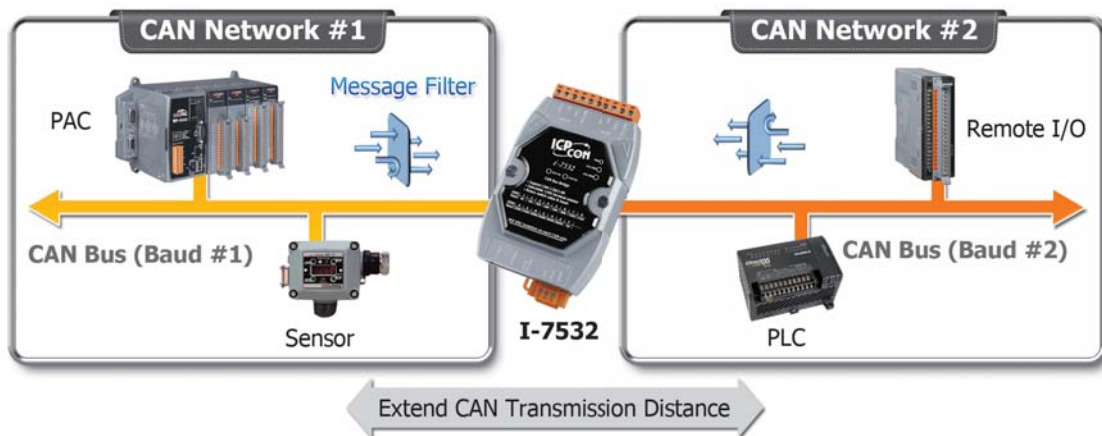

NEW

## Isolated 4-Port CAN Bus Switch

**I-2534**    **I-5534-M**



The I-2534/I-5534-M provides 4 isolated independent CAN ports that can be used to link 4 CAN networks. The I-2534/I-5534-M follows the ISO 11898-2 specification which is applied in widely range of CAN-based protocols. In order to fit the industrial application, this module provides the functions of reshaping the CAN signals and isolating the disturbance among 4 CAN ports. When users apply the I-2534/I-5534-M in the CAN networks which use different baud rate, the I-2534/I-5534-M offers the baud rate configuration, CAN message filters, and message router, and effectively help users solve the problems related to network-to-network data exchanging, message filtering and routing, and tree topology for the CAN bus. The transmission distance limitation for each CAN port of the I-2534/I-5534-M is independent, which means that the total length of the network can be extended.

- 4 CAN communication ports
- 3 kV DC-DC isolation and 2500 Vrms isolation
- Fully compatible with the ISO 11898-2 standard
- The message filter for each CAN port is configurable
- I-5534-M is for the metallic casing
- Power requirements: Unregulated +10 VDC ~ +30 VDC
- Compatible with CAN specification 2.0 parts A and B Supports baud rates from 5 kbps ~ 1 Mbps
- DIP switch for the 120 Ω terminator resistor of the CAN bus
- Rotary switch used to select the baud rate for each CAN port

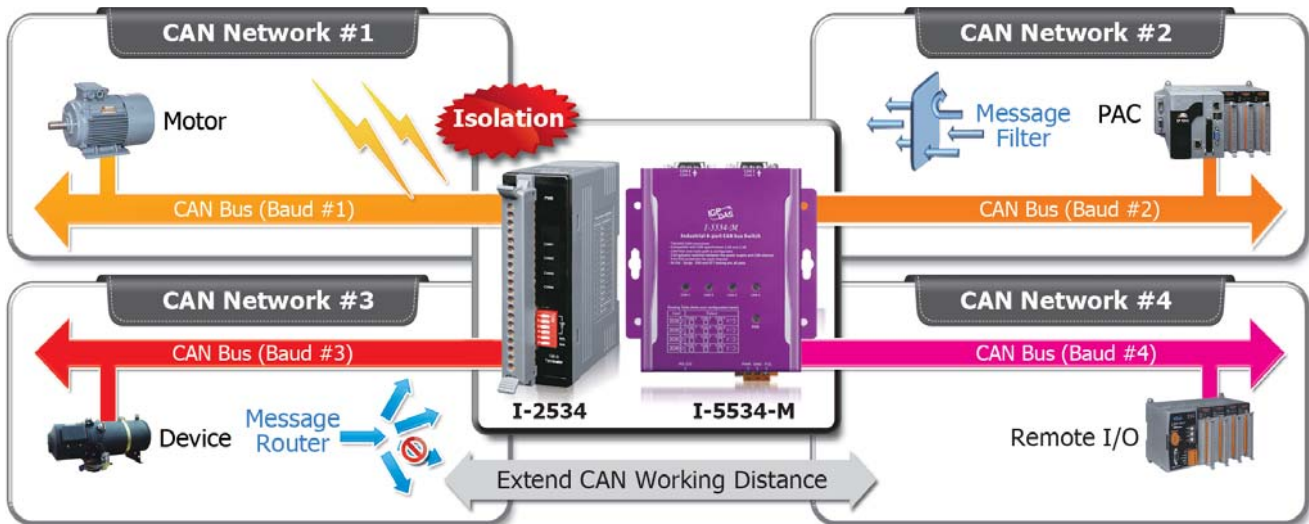

### CAN bus network (Heavy bus loading)

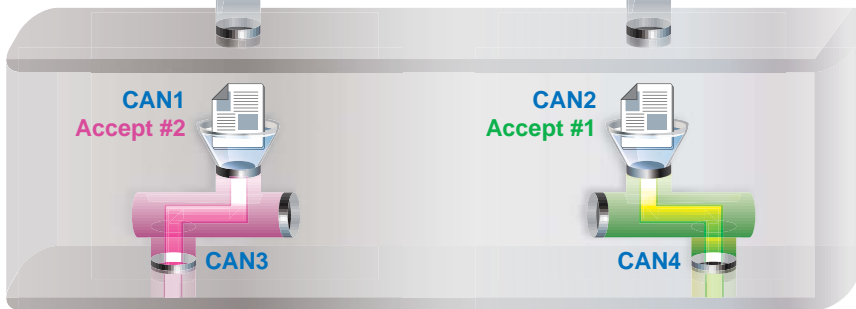

CAN bus with only #2 message (Light bus loading)

CAN bus with only #1 message (Light bus loading)

### 4.3 CAN Converters

ICP DAS CAN converters are used to establish a physical coupling of two or more communication interface, and are infrastructure components with which complex network structures can be implemented. They can be used to implement the data conversion between CAN and USB, Uart, Ethernet or Wi-Fi interface.

- CAN to USB: I-7565 series
- CAN to Fiber: I-253x series
- CAN to Ethernet or Wi-Fi: I-7540 series
- CAN to Uart: I-7530 series



#### 4.3.1 USB to CAN Converters



The I-7565 series is the USB to CAN converter with a maximum of two independent CAN channels that supports CAN protocols 2.0A and 2.0B. It becomes very convenient and easy to access and control the CAN devices via the USB port of the PC.

Model Name	I-7565	I-7565-H1	I-7565-H2	I-7565-CPM	I-7565-DNM
Pictures					
<b>USB Interface</b>					
Connector	USB Type B				
Compatibility	USB 1.1 and 2.0 standard				
<b>Compatibility</b>					
Cannel	1	1	2	1	1
Transceiver	Philips 82C250	NXP TJA1042		NXP 82C250	NXP 82C250
Connector	9-pin male D-Sub		10-pin terminal block	9-pin male D-Sub	
Baud Rate	10k, 20k, 50k, 100k, 125k, 250k, 500k, 800k, 1M				125k, 250k, 500k
Isolation	3000 Vrms			3000 Vdc	
Terminator Resistor	Selectable 120 Ω terminator resistor by a jumper				
Protocol	CAN 2.0A/2.0B			CiA 301 V4.02	DeviceNet Volume I ver2.0, Volume II ver2.0
Receive Buffer	1000 data frames	256 data frames	128 data frames for each CAN port	1000 data frames	256 data frames
Max. Data Flow	250 fps	3000 fps	1500 fps for each CAN port	-	-
<b>System</b>					
Software Drivers	Windows 2K/XP/7, Linux				
Software SDK	N/A			VB6, VC++ 6.0, C#, VB .NET	VB6, VC++ 6.0, BCB 6.0
LED Indicators	PWE, RUN, ERR	PWE, RUN, ERR	PWE, RUN, ERR	PWR, ACT, ERR, Tx/Rx	PWR, RUN, NS, MS
Power Consumption	1.5 W			3 W	3 W
Dimensions (W x W x D)	108 mm x 72 mm x 35 mm				



## USB to CAN Converter

### I-7565



The I-7565 is a cost-efficient device for coupling the CAN-bus to the PC using the standard USB interface. Nowadays the interface is present in every new PC and is supported by the Windows operating systems. If you establish the connection between the I-7565 and the PC during the runtime of the computer, the PC automatically loads the relevant device driver (hot plug & play).

- I-7565 used PL-2303 USB chip, I-7565F used FTDI USB chip. Both of two chips used different drivers.
- Driver supported for Windows 2K/XP/Vista/7 (32 or 64-bit), and Linux
- Powered by the USB port (no external power supply required)
- Jumper for the 120 Ω terminator resistor of the CAN bus
- Supports a range of baud rates from 10 kbps ~ 1 Mbps
- Compatible with CAN specification 2.0 parts A and B
- 2500 Vrms photocoupler isolation on the CAN side
- Fully compatible with the ISO 11898-2 standard
- Fully compliant with USB 1.1/2.0 (Full Speed)
- 3 kV galvanic isolation for the CAN port
- One CAN port and one USB channel



## High-performance 1-Port USB to CAN Converter

### I-7565-H1



The I-7565-H1 is a high-performance intelligent USB to CAN converter with one CAN port that can help users to make data collection and process on a CAN bus network easily and quickly. It improves the transformation speed of the I-7565, and allows receiving max. 3000 standard 2.0A CAN frames per second. The powerful CPU of the I-7565-H1 provides the accurately time-stamp for each CAN message that is useful to analysis and diagnostic the CAN network.

- Provides a configuration utility that can be used to transmit/receive CAN messages
- Driver supported for Windows 2K/XP/Vista/7 (32 or 64-bit)/8.x , and Linux
- Max. data flow for a single channel is 3000 fps (standard frame)
- No external power supply required (powered by the USB port)
- Built-in jumper for the 120 Ω terminal resistor of the CAN bus
- Programmable CAN bus baud rate from 5 kbps ~ 1 Mbps
- Compatible with CAN specification 2.0 parts A and B
- 2500 Vrms photocoupler isolation on the CAN side
- Supports CAN bus acceptance filter configuration
- Fully compatible with the ISO 11898-2 standard
- 3 kV galvanic isolation for the CAN port
- Removable terminal block
- Provides one CAN port



### High-performance 2-Port USB to CAN Converter

#### I-7565-H2



The I-7565-H2 is a high-performance intelligent USB to CAN converter with two CAN channels that help users to make data collection and process on a CAN bus network easily and quickly. The important feature of I-7565-H2 is to support the user-defined baud rate function no matter what the baud rate is. When connecting I-7565-H2 to PC, PC will load the relevant device driver automatically (hot plug & play). Therefore, users can make data collection and processing of CAN bus network easier and quicker by applying I-7565-H2.

- Provides a configuration utility that can be used to transmit/receive CAN messages
- Driver supported for Windows 2K/XP/Vista/7 (32 or 64-bit)/8.x , and Linux
- Max. data flow for a single channel is 3000 fps (standard frame)
- No external power supply required (powered by the USB port)
- Built-in jumper for the 120 Ω terminal resistor of the CAN bus
- Programmable CAN bus baud rate from 5 kbps ~ 1 Mbps
- Compatible with CAN specification 2.0 parts A and B
- 2500 Vrms photocoupler isolation on the CAN side
- Supports CAN bus acceptance filter configuration
- Fully compatible with the ISO 11898-2 standard
- 3 kV galvanic isolation for the CAN port
- Provides two CAN ports



### Intelligent USB to CANopen Converter

#### I-7565-CPM



I-7565-CPM can represent an economic master solution of CANopen application. It follows CiA 301 specification such as, SDO, PDO, NMT, SYNC and so on. Besides, I-7565-CPM support EDS file interpretation, Heartbeat, Guarding, Slave Boot-up detection, and EMCY event functions. It is suited for portable diagnostic tool or main control unit of a CANopen network.

- Support event trigger, such as EMCY event, Guarding event, Heartbeat event, and Slave Boot-up events
- Support baud: 10 Kbps, 20 Kbps, 50 Kbps, 125 Kbps, 250 Kbps, 500 Kbps, 800 Kbps, and 1 Mbps
- Driver supported for Windows 2K/XP/Vista/7 (32 or 64-bit), and Linux
- Support NMT, PDO, SDO, SYNC and EMCY protocol
- Four indication LEDs (Pwr, Tx/Rx, Act and Err LEDs)
- Support VC6, VB6, VB.net, and C# development
- Support Node Guarding and Heartbeat protocol
- Free software development tools for windows
- Support on-line adding and removing devices
- Fully compliant with USB 1.1/2.0 (Full Speed)
- Support Auto-Search slave device functions
- Provide demos and utility
- Allow CiA DS-301 V4.02
- Support EDS File



## Intelligent USB to DeviceNet Converter

### I-7565-DNM

I-7565-DNM can represent an economic master solution of DeviceNet application. It is a "Predefined Master-Slave connection Set". I-7565-DNM supports Group 2 only Server and UCMM functions to communication with slave devices. It has an independent CAN bus communication port to cover a wide range of DeviceNet applications.

Besides, I-7565-DNM uses the new CAN controller Phillips SJA1000T and transceiver 82C250, which provide bus arbitration, error detection with auto correction and re-transmission function. It can be installed on almost any windows-based system. It is popularly applied in the industrial automation, building automation, vehicle, marine, and embedded control network. In order to expand the DeviceNet functions of ICP DAS products, I-7565-DNM is developed for this purpose.

- Fully compliant with USB 1.1/2.0 (Full Speed)
- DeviceNet Version: Volume I & II, Release 2.0
- Programmable Master MAC ID and Baud Rate
- Support Group 2 and UCMM connection
- Support Auto-Search slave device function
- Support Auto-detect Group 2 and UCMM device
- Status LED: RUN, MS, NS
- Baud Rate: 125k, 250k, 500k
- Slave Node: 63 nodes Max
- Support on-line adding and removing devices
- Auto-Reconnect when the connection is broken
- Free Software development tools for Windows
- I/O Length: 512 Bytes Max. (Input/Output) per slave
- I/O Operating Modes: Poll, Bit-Strobe, Change of State/Cyclic
- Driver supported for Windows 2K/XP/Vista/7 (32 or 64-bit), and Linux
- No external power supply is required as I-7565 takes it's power from the USB bus

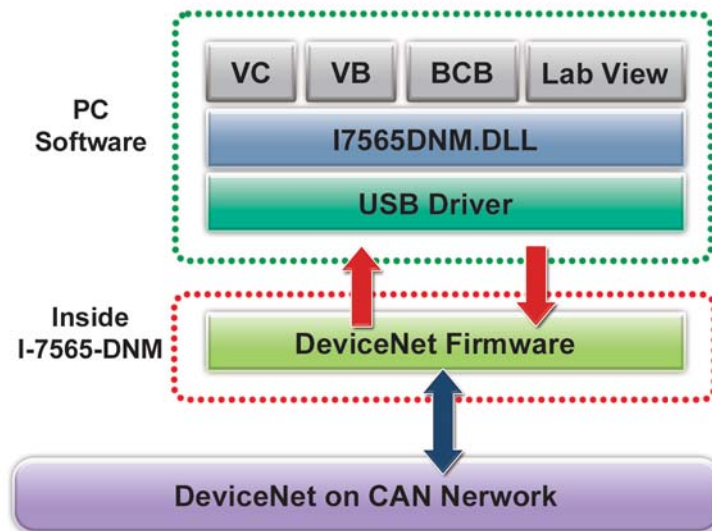
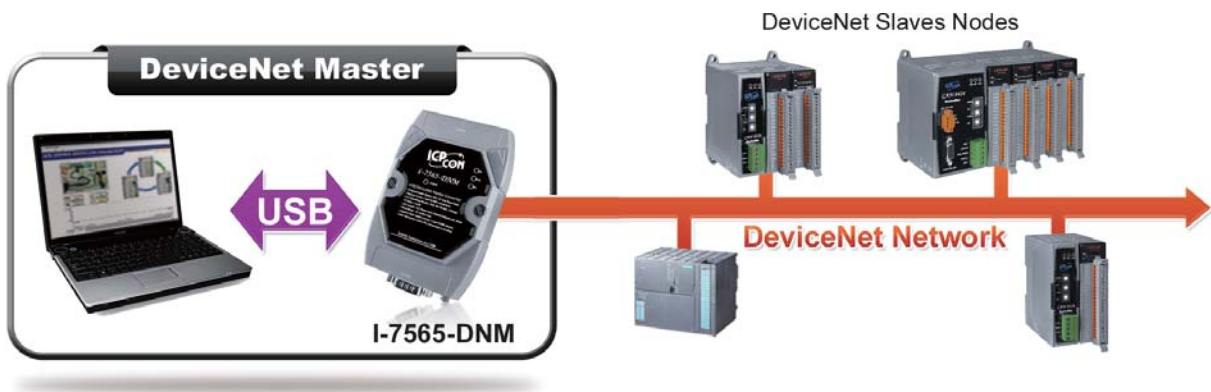

### 4.3.2 CAN to Fiber Converter/Bridge



Models	I-2532	I-2533	I-2533CS	I-2533CS-60	I-2533CS-A/I-2533CS-B
	CAN to Multi-mode Fiber Converter	CAN to Multi-mode Fiber Bridge	CAN to Single-mode Fiber Bridge		
Pictures					
<b>CAN Interface</b>					
Connector	Screwed terminal block (CAN_GND, CAN_L, CAN_H)				
Baud Rate (bps)	10 k ~ 500 k	10 k ~ 1 M			
Transmission Distance (m)	Depends on baud rate				
Propagation Delay	Max 125 ns	Max. 125 μs (depends on the CAN baud rate)			
Terminator Resistor	DIP switch for the 120 Ω terminator resistor				
Isolation	3000 VDC for DC-to-DC, 2500 Vrms for photo-couple				
Specification	ISO 11898-2, CAN 2.0A and CAN 2.0B				
<b>Fiber Interface</b>					
Connector	ST (Multi-mode)		SC (Single-mode)		SC type
Wave Length (nm)	850		1300 or 1310		TX: 1310, RX: 1550 for I-2533CS-A TX: 1550, RX: 1310 for I-2533CS-B
Fiber Cable (μm)	Multi-mode 50/125, 62.5/125 or 100/140		Single-mode 8.3/125, 8.7/125, 9/125 or 10/125		
Transmission Distance	Max. 1.4 km	Max. 2 km	Max. 30 km	Max. 60 km	Max. 15 km
<b>UART Interface</b>					
COM1	–	RS-232 (for configuration)			
COM 1 Connector	–	3-pin screwed terminal block (Rx, Tx, GND)			
Transmission Speed (bps)	–	115200			
Data bit	–	8			
Stop bit	–	1			
Parity	–	None			
<b>LED</b>					
Round LED	PWR LED, TD LED, RD LED	PWR LED, CAN_Tx LED, CAN_Rx LED, CAN_Err LED, FB_Err LED	PWR LED, CAN_Tx LED, CAN_Rx LED, CAN_Err LED, FB_Err LED, FB_Ack LED		
<b>Power</b>					
Power Supply	Unregulated +10 VDC ~ +30 VDC				
Protection	Power reverse polarity protection, Over-voltage brown-out protection				
Power Consumption	0.5 W	3 W			
<b>Mechanical</b>					
Installation	DIN-Rail				
Dimensions (W x L x H)	32.3 mm x 107 mm x 102 mm		33.0 mm x 126.8 mm x 104.5 mm		
<b>Environment</b>					
Operating Temperature	-25°C ~ +75°C				
Storage Temperature	-30°C ~ +80°C				
Relative Humidity	10 ~ 90% RH, Non-condensing				

## CAN to Multi-mode Fiber Converter

### I-2532



The I-2532 is a CAN to fiber optic converter, and fits to various CAN-based applications, such as CANopen, DeviceNet, J1939, and so forth. The module is designed not only to convert CAN bus signals to optical signals on a fiber optic cable, to reshape the CAN signal to compensate for distortion, but to isolate the bus error due to the wire short or disturbance. With the advantage of fiber optic, the I-2532 enables secure data transmission via fiber optic transmission, and helps the CAN network to prevent the noise from EMS/RFI interference. In order to use the I-2532 easily and conveniently, the converter is designed to automatically tune the baud rate by itself to match the CAN network. Users just connect the I-2532 with the fiber optic cable and CAN bus and check the terminator resistor and power it on, then the I-2532 enable to work normally.

### I-2532-M

I-2532-M is a CAN to multi-mode fiber converter that with the same specifications as I-2532 but with metal housing.

If you need other products with metal housing, call us.

The dimensions are W x H x D = 77 x 81 x 28 mm

- Compatible with CAN specification 2.0 parts A and B
- Supports a range of baud rates from 10 kbps ~ 500 kbps
- DIP switch for the 120 Ω terminator resistor of the CAN bus
- Fiber Port: ST (Multi-mode)
- Fiber Cable: 62.5/125 μm
- Fully compatible with the ISO 11898-2 standard
- 2500 Vrms photocoupler isolation on the CAN side
- 3 kV galvanic isolation
- Wavelength: 850 nm
- One CAN and one fiber channel

### I-2532-M Metal Housing Product

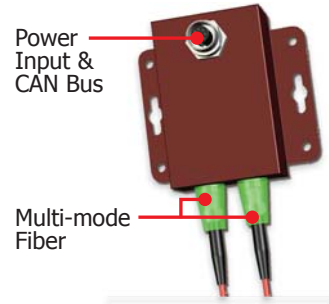

### Single CAN Network

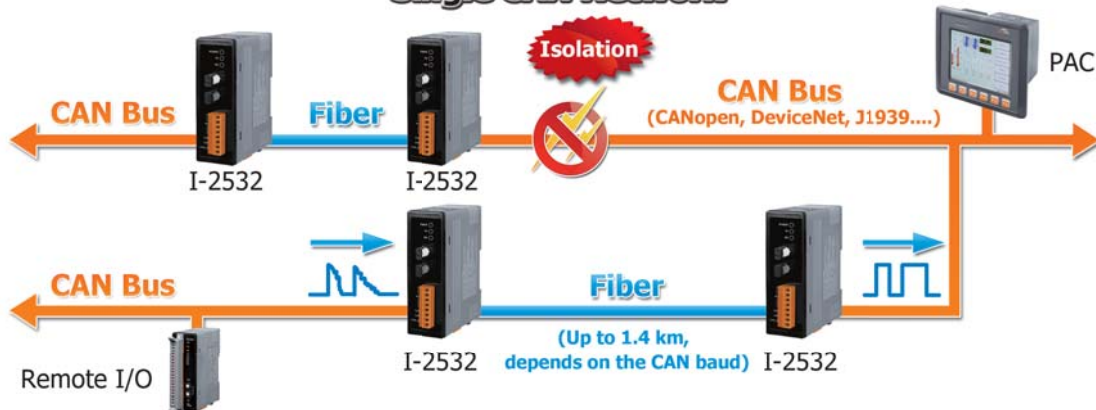

### Block Diagram of I-2532

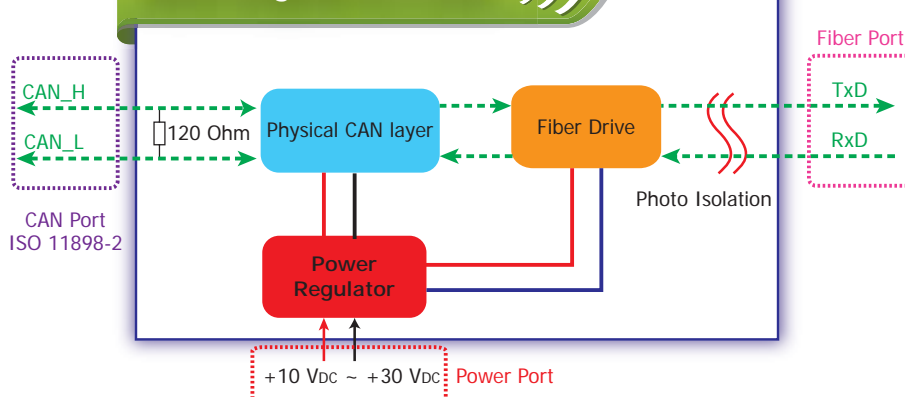

NEW

## CAN to Multi-mode Fiber Bridge

### I-2533



The I-2533 is an intelligent CAN bridge that can be used to establish the connection between two CAN bus systems via fiber optic cable. Similar to the I-2532, the I-2533 can also apply in various CAN-based protocols to convert CAN bus signals to optical signals and reshape the CAN signals. The difference between the I-2532 and I-2533 is the CAN configuration functions and the distance limitation of CAN communication. The I-2533 offers the functions to configure the CAN baud rate and CAN message filters. These are useful when using the I-2533 to link two CAN networks which may have different baud rates. By using the I-2533, the transmission distance limitation of the CAN bus system will not be reduced because of the CAN baud rate, which means that the total network length can be extended. This feature means that users can develop the applications more powerful and flexible with the I-2533.

- Fiber Port: ST (Multi-mode)
- Fiber Cable: 62.5/125  $\mu\text{m}$
- Up to 100 CAN nodes on each channel
- Broken line detection for fiber cable
- Wavelength: 850 nm
- 2500 Vrms iCoupler isolation on the CAN side
- Built-in switch for the 120  $\Omega$  terminator resistor
- Rotary switch for CAN baud rate configuration
- Fully compatible with the ISO 11898-2 standard
- Software utility tool for message filter configuration
- Compatible with CAN specification 2.0 parts A and B
- Max. transmission distance of up to 2 km at any CAN baud rate

4

CAN Bus

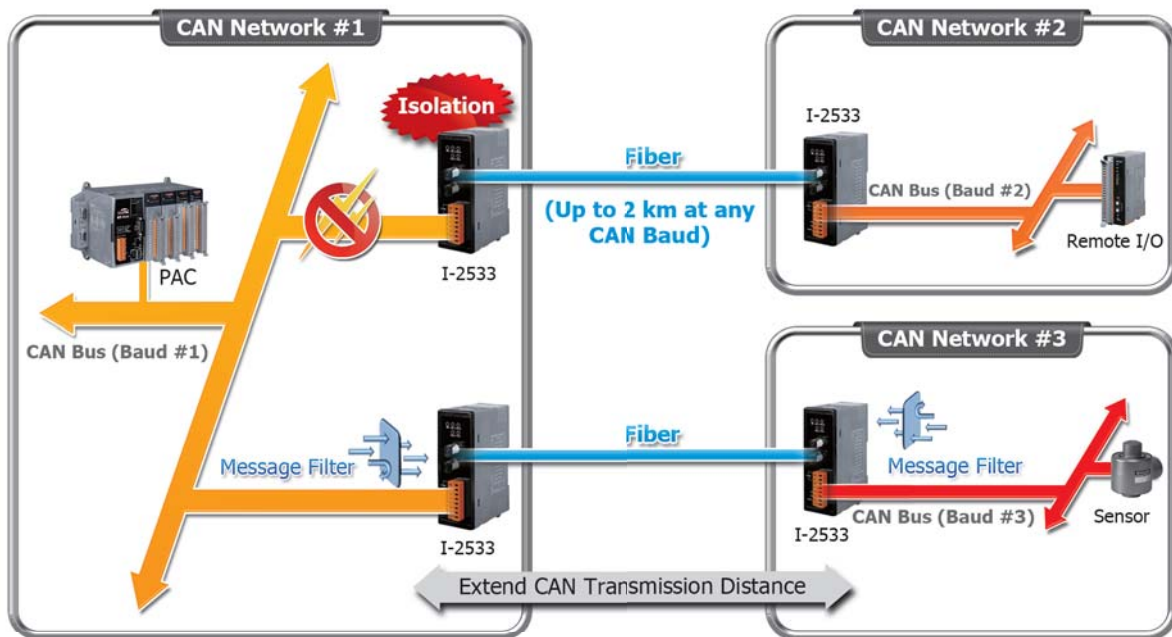

### Block Diagram of I-2533

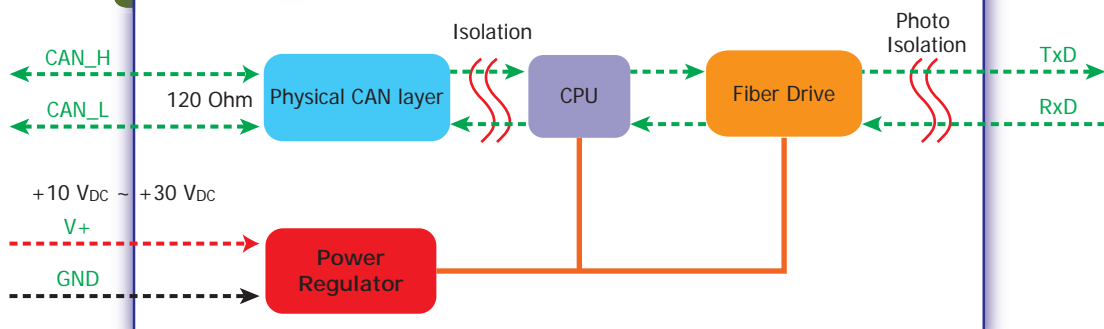

NEW

## CAN to Single-mode Fiber Bridge

### I-2533CS

### I-2533CS-60 **NEW**



The I-2533CS series (I-2533CS/I-2533CS-60) is a local CAN bridge used to establish a connection between two CAN bus systems via single mode fiber transmission medium. In order to solve the problem between CAN and fiber transmission mediums, the I-2533CS series is specially designed for converting the electrical CAN bus signal to the optical signal- and recover the signal to CAN bus by using another I-2533CS series. Compared with other CAN/ Fiber converters, the I-2533CS series has three more important features. First, the transmission distance limitation of the CAN bus system will not be reduced due to higher CAN baud rate. No matter what kind of CAN baud rates you use, the data transmission distance of fiber is up to 30 km (60 km for I-2533CS-60). It means that the total network working distance can be extended.

- 4 Fully compatible with the ISO 11898-2 standard
- 4 Support both CAN 2.0A and CAN 2.0B
- 4 NXP TJA1042 CAN transceiver
- 4 Wave Length: 1310 nm
- 4 2500 Vrms isolation on the CAN side
- 4 Transmission distance up to 30 km at any CAN baud rate (60km for I-2533CS-60)
- 4 Build-in switch to select 120 Ω terminal resistor
- 4 Fiber Cable: 8.3/125, 8.7/125, 9/125 or 10/125 μm
- 4 Allow user-defined CAN baud rate
- 4 3 kV galvanic isolation between the power supply and CAN channel
- 4 Rotary switch for CAN baud rate configuration
- 4 Utility tool for CAN message filter configuration

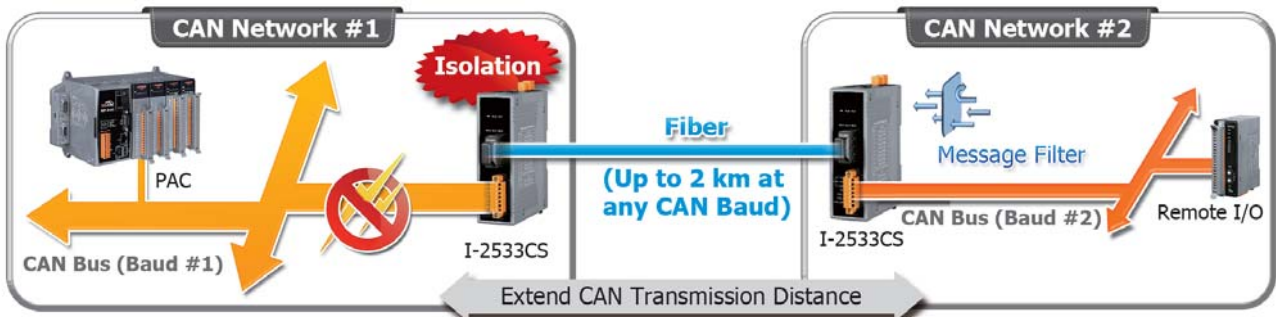

## CAN to Multi-mode Fiber Bridge

### I-2533CS-A

### I-2533CS-B



The I-2533CS-A/B is a type of CAN-to-Fiber Bridge that can be used to establish a connection between two CAN networks. It supports Wavelength Division Multiplexing (WDM) technology so that only a single fiber cable is needed for transmitting bi-directional CAN data. As the I-2533CS-A and I-2533CS-B must be paired because of hardware limitations, this means that the cost of deploying fiber cable can be effectively reduced. Compared with other CAN/Fiber converters, the I-2533CS-A/B has three significant features. First, the I-2533CS-A/B can be used to overcome the transmission distance limitations of the CAN Bus. Consequently, the transmission distance can be extended to up to 15 km using fiber cable, regardless of the CAN baud rates used in the system.

- Embedded NXP TJA1042 CAN transceiver
- 2500 Vrms isolation on the CAN side
- 120 Ω terminal resistor selectable via DIP switch
- CAN baud rate configurable via rotary switch
- Fiber Type: SC, Single mode, 100 Base-FX
- Utility for CAN message filter configuration
- Allows user-defined CAN baud rates
- Fully compatible with the ISO 11898-2 standard
- Wavelength: • Tx: 1310 nm, Rx: 1550 nm for I-2533CS-A  
• Tx: 1550 nm, Rx: 1310 nm for I-2533CS-B
- Fiber Cable: 8.3/125, 8.7/125, 9/125 or 10/125 μm
- Supports both CAN 2.0A and CAN 2.0B specifications
- Max. transmission distance up to 15 km at any CAN baud rate
- 3 kV galvanic isolation between the power supply and the CAN channel

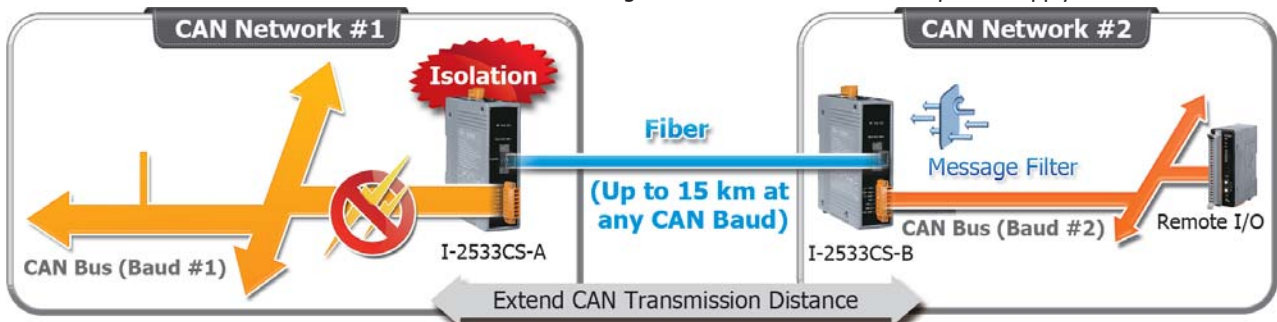

## 4.3.3 Ethernet/Wi-Fi to CAN Converters

The Ethernet or Wi-Fi to CAN converters are the solutions that enable CAN networks to be integrated into the Internet/Ethernet or Wi-Fi, whereby remote monitor and control is possible.

The I-7540D-WF supports the wireless transmission of CAN data between a CAN network and a WLAN network according to the 802.11b/g standard. The I-7540D-WF is highly suitable for connecting mobile (e.g., vehicles or machines) or stationary CAN networks and is often used for short ranges up to 100 m.

The Ethernet or Wi-Fi converters help to implement various Ethernet or wireless transmission applications.

Models	I-7540D	I-7540D-MTCP	ECAN-240	I-7540D-WF
Pictures			Available Soon	
<b>CAN Interface</b>				
Controller	NXP SJA1000T with 16 MHz clock		Microprocessor inside	CAN Controller inside
Transceiver	NXP 82C250		TJA 1042	NXP 82C250
Channel number	1		2	1
Connector	2-pin screwed terminal block (CAN_L, CAN_H)		9-pin male D-Sub for each CAN port	3-pin screwed terminal block (CAN_L, CAN_H, CAN_GND)
Baud Rate (bps)	10 k, 20 k, 50 k, 125 k, 250 k, 500 k, 800 k, 1 M			
Isolation	1000 VDC for DC-to-DC, 2500 Vrms for photo-couple		3000 VDC for DC-to-DC, 2500 Vrms for photo-couple	
Terminator Resistor	Jumper for 120 Ω terminator resistor			
Specification	ISO-11898-2, CAN 2.0A and CAN 2.0B			
<b>UART Interface</b>				
COM 1	RS-232			
COM 1 Connector	5-pin screwed terminal block (TxD, RxD, RTS, CTS, GND )		–	3-pin screwed terminal block (TxD, RxD, GND )
COM 2	RS-485 (Self-Turner inside)		–	–
COM 2 Connector	2-pin screwed terminal block (DATA+, DATA-)		–	–
Baud Rate (bps)	110, 150, 300, 600, 1200, 2400, 4800, 9600, 19200, 38400, 57600, 115200		–	115200
Data bit	7, 8		–	8
Stop bit	1		–	1
Parity	None, Even, Odd		–	None
Protocol	ICP DAS Protocol	Modbus RTU	–	For Configuration
<b>Ethernet Interface</b>				
Controller	10/100Base-TX Ethernet Controller (Auto-negotiating, Auto_MDIX)		10/100Base-TX Ethernet Controller (Auto-negotiating, Auto_MDIX)	–
Connector	RJ-45 with LED indicator		RJ-45 with LED indicator	–
Protocol	ICP DAS Protocol	Modbus TCP	Modbus TCP Server/Client UDP, Http for configuration	–
<b>Wi-Fi Interface</b>				
Antenna	–		5 dBi (Omni-Directional)	
Standard Supported	–		IEEE 802.11b/g	
Operation Mode	–		Infrastructure & Ad-hoc	
Encryption	–		WEP, WPA and WPA2	
Frequency Ranges	–		2.412GHz ~ 2.484GHz	
Transmission distance	–		Up to 100 meters	
<b>Mechanical</b>				
Installation	DIN-Rail			
Dimensions (W x L x H)	72 mm x 122 mm x 33 mm		72.5mm x 110mm x 102mm (W x H x D)	117 mm x 76 mm x 37 mm
<b>Environment</b>				
Operating Temperature	-25°C ~ +75°C			
Storage Temperature	-30°C ~ +80°C			
Relative Humidity	10 ~ 90% RH, Non-condensing			



## Modbus TCP to CAN Converter

### I-7540D-MTCP



Inheriting to the most of all features of the I-7540D, the I-7540D-MTCP enables CAN networks to be combined with the Internet/Ethernet. It can be used to not only access the CAN network via the Ethernet, but can also realize Ethernet transparent transmission on the CAN network. In order to connect the PLCs, HMIs and SCADAs with the CAN devices more easily and conveniently, the I-7540D-MTCP supports the Modbus TCP and Modbus RTU communication protocol. This module can act as a Modbus TCP server, and wait for the commands from the Modbus TCP client. When the controller is a Modbus RTU master, the I-7540D-MTCP is able to be the Modbus RTU slave, and transfer the Modbus RTU commands to the CAN messages. These features mean that users can setup their applications more flexibly and conveniently.

- Built-in watchdog
- 1 kV galvanic isolation
- Compatible with CAN specification 2.0 parts A and B
- Fully compatible with the ISO 11898-2 standard
- Supports a range of baud rates from 10 kbps ~ 1 Mbps
- Jumper for the 120 Ω terminator resistor of the CAN bus
- Supports Modbus function code: 0x03/0x04/0x10
- 2500 Vrms photocoupler isolation on the CAN side
- Support maximum 24 Ethernet clients connection
- Includes a software utility for monitoring and configuration
- Support 30 specific CAN IDs in the Modbus TCP/RTU mode
- Provide the transparent communication between the CAN devices via Ethernet
- Provides one channel each for CAN, RS-232, RS-485 and 10/100 Base-T Ethernet



Available soon

## Modbus TCP Client/Server to two CAN ports Converter

### ECAN-240



ECAN-240 is a Ethernet to CAN two ports converter. Users can communicate with different CAN networks at the same time. In order to be used more easily in industry, the ECAN-240 supports Modbus TCP client and Modbus TCP server function. Users can choose one of them for fitting their application.

Furthermore, the two CAN ports have different purposes according to their usages. For example: In pair connection mode, the different CAN networks can be communicated with each other via module configuration.

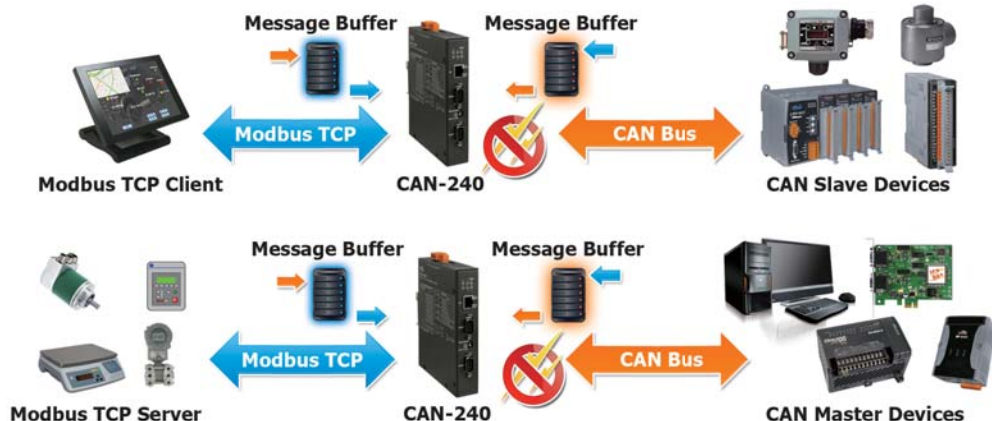

### Ethernet to CAN Converter

#### I-7540D



The I-7540D is a CAN to Ethernet converter, and is usually applied as an Ethernet to CAN/RS-232/485 Device Server. It supports socket access functions and virtual COM port technology which helps users to get the CAN, RS-232, RS-485 data via virtual COM port. The I-7540D also provides transparent mode, which enables CAN networks to be coupled together over the Internet/Ethernet, whereby remote monitoring and control is possible. By the features of tiny operating system, protocol independence, small casing and flexibility, it is able to widely fit various RS-232, RS-485 and CAN applications, which may be based on private RS-232 protocol, private CAN protocol, Modbus protocol, CANopen protocol, DeviceNet protocol or J1939 protocol.

- 1 kV galvanic isolation
- 10/100 Base-T Ethernet port
- Supports the Virtual COM technology
- Fully compatible with the ISO 11898-2 standard
- 2500 Vrms photocoupler isolation on the CAN side
- Compatible with CAN specification 2.0 parts A and B
- Supports a range of baud rates from 10 kbps ~ 1 Mbps
- Impedance matching for the 120 Ω terminator resistor of the CAN bus
- Provides connections for a maximum of 25 Ethernet clients
- Provide one channel each for CAN, RS-232, RS-485 and Ethernet
- Provide the transparent communication between the CAN devices via Ethernet

4

CAN Bus

### General Application

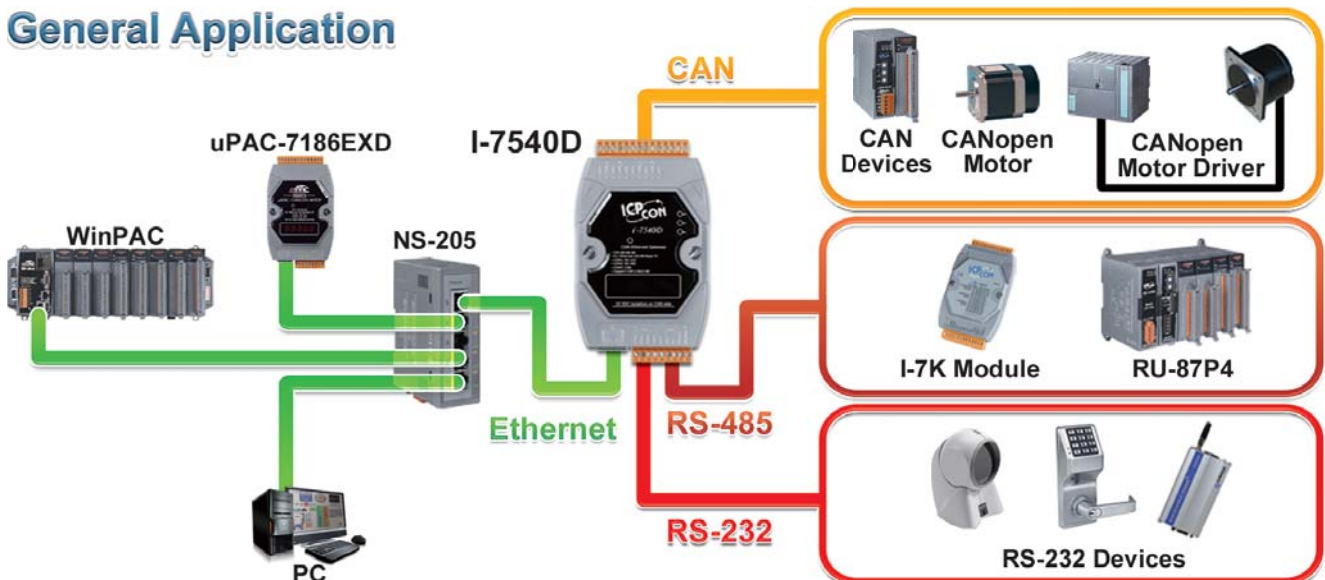

### Extend CAN communication distance

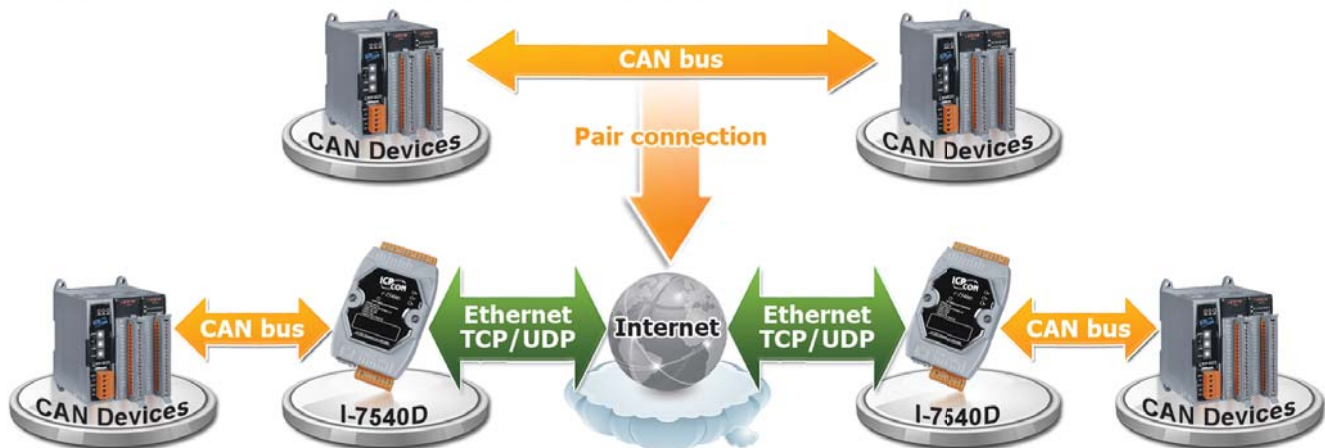

## Wi-Fi to CAN Converter

### I-7540D-WF

The I-7540D-WF supports the wireless transmission of CAN data between a CAN network and a WLAN network according to the 802.11b/g standard. It provides CAN to WLAN converter functionality together with wireless transparent transmission on the CAN network. The I-7540D-WF is highly suitable for connecting mobile (e.g., vehicles or machines) or stationary CAN networks and is often used in short ranges up to 100 m. Using an appropriately configured router, CAN data can be determined to pass or filter from the CAN networks to the Ethernet. The wireless connection that is established between two I-7540D-WF units can be used instead of a cable, and enables the connection of CAN networks that would otherwise be difficult to link such as rotational machineries.



- IEEE 802.11 b/g compliant
- Wireless data transmission via WLAN
- Connects CAN networks via a WLAN bridge
- Compatible with CAN specification 2.0 parts A and B
- Wireless transmission distance: up to 100 meters
- Two different operation modes: infrastructure and ad-hoc
- Supports WEP, WPA and WPA2 encryption for wireless LAN
- Point to point or point to multi-point connection via wireless LAN
- Communication efficiency (peak value): one-way is up to 700 fps (client->server, server->client), two-way 350 fps (client<=>server)



### Ad hoc mode (AP is not necessary)



**Case Studies: Modbus TCP to CAN converter**

**Location: Taiwan**

By using the OBD-II interface, the I-7565-H1 and CANcheck software can be used to diagnose the vehicle. In the usual maintenance, the I-7565-H1 with CANcheck software could help to check vehicle safety systems and sensing components, including airbags, ABS, brake systems, oxygen sensors, and etc.. That will shorten the diagnostic time and make the maintenance become easy. In other CAN-based applications or equipments, the I-7565-H1 and CANcheck software would be the great and friendly tool.

Main Description	Minor Description	Start Time	End Time	Result	Remark
Engine Speed	1040 RPM				
Engine Speed	3040 RPM				
Engine Speed	5040 RPM				
Engine Speed	8040 RPM				
Vehicle Speed	35 km/hr				
Vehicle Speed	55 km/hr				
Vehicle Speed	85 km/hr				
Vehicle Speed	110 km/hr				
Vehicle Speed	123 km/hr				

**CAN Bus**

Compressor

**I-7540D-MTCP**

**Modbus TCP**

### 4.3.4 Uart to CAN Converters

The I-7530 series is the Uart to CAN converter that support CAN protocols 2.0A and 2.0B. The I-7530-FT is designed for the fault tolerance CAN bus (ISO 11898-3). The I-7530A-MR supports Modbus RTU command especially.

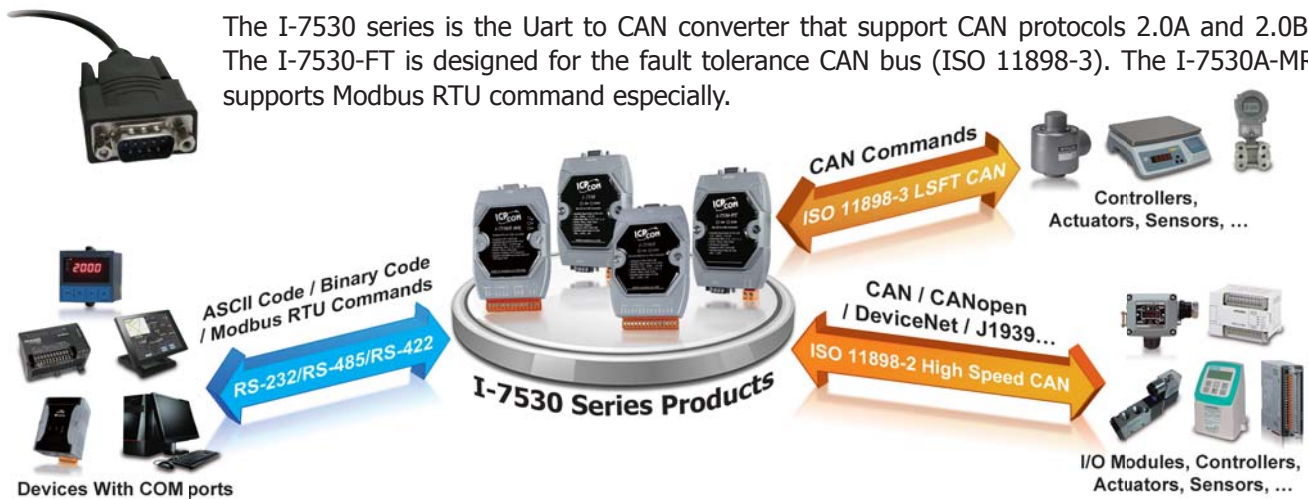

Models	I-7530-FT	I-7530	I-7530T	I-7530A	I-7530A-MR	tM-7530
Pictures	RS-232 to Fault-Tolerance CAN Converter 	RS-232 to CAN Converter 	RS-232 to CAN Converter 	RS-232/422/485 to CAN Converter 	Modbus RTU to CAN Converter 	Tiny RS-232 to CAN Converter 
<b>CAN Interface</b>						
Transceiver	AMIS 41682	NXP 82C250	TJA1042	NXP 82C250		NXP TJA1042
Connector	9-pin male D-sub					3 pins spring type terminal block
Baud Rate	10k, 20k, 50k, 125k bps	10k, 20k, 50k, 125k, 250k, 500k, 800k, 1M bps				
Protocol	ISO 11898-3 (low speed fault tolerance), CAN 2.0A and CAN 2.0B	ISO 11898-2, CAN 2.0A and CAN 2.0B				
Receiver Buffer	1000 data frames					256 data frames
Isolation	–	3000 VDC for DC-to-DC				1000 VDC for DC-to-DC
<b>UART Interface</b>						
Type	RS-232			RS-232/422/485		RS-232
Protocol	–			Modbus RTU slave		–
Connector	9-pin female D-sub			14-pin terminal block		9-pin female D-sub
Baud Rate	110, 150, 300, 600, 1200, 2400, 4800, 9600, 19200, 38400, 57600, 115200 bps			300, 600, 1200, 2400, 4800, 9600, 19200, 38400, 57600, 115200, 230400 bps		
Receiver Buffer	900 data frames					256 bytes
<b>System</b>						
Power Consumption	1 W					
Power Input	+10 VDC ~ +30 VDC					
Dimensions (W x L x H)	72 x 118 x 33 (mm)					52 x 98 x 27 (mm)
Operating Temperature	-25°C ~ +75°C					
Storage Temperature	-30°C ~ +80°C					

**Performance Table**

I-7530, I-7530FT, I-7530A performance table:

**The test is the performance which transfer 8 bytes data frame from CAN to RS-232 (for I-7530/I-7530T)**

CAN setting	Transfer frames	Transfer time (ms)	RS-232 setting	Receive frames	Receive time (ms)	The max frames/sec	Data<8 bytes/frame	RS-232 command length
2.0A 1 Mbps	1,000	200	115200, n, 8, 1	1,000	2954	338	>=338	22 B
2.0A 1 Mbps	1,000	200	115200, n, 7, 1	1,000	2775	360	>=360	22 B
2.0B 1 Mbps	1,000	200	115200, n, 8, 1	1,000	3580	279	>=279	27 B
2.0B 1 Mbps	1,000	200	115200, n, 7, 1	1,000	3337	299	>=299	27 B

**The test is the performance which transfer 8 bytes data frame from RS-232 to CAN (for I-7530/I-7530T)**

CAN setting	Transfer frames	Transfer time (ms)	RS-232 setting	Receive frames	Receive time (ms)	The max frames/sec	Data<8 bytes/frame	RS-232 command length
2.0A 1 Mbps	1,000,000	2,612,243	115200, n, 8, 1	1,000,000	2,612,243	382	>=382	22 B
2.0A 1 Mbps	1,000,000	2,441,130	115200, n, 7, 1	1,000,000	2,441,130	409	>=409	22 B
2.0B 1 Mbps	1,000,000	3,142,043	115200, n, 8, 1	1,000,000	3,142,043	318	>=318	27 B
2.0B 1 Mbps	1,000,000	3,142,043	115200, n, 7, 1	1,000,000	2,966,646	337	>=337	27 B

I-7530A-MR performance table:

**RS-232/422 full-duplex communication mode**

CAN setting	RS-232/422 setting	RS-232/422 command length	The max frames/sec
2.0B 1 Mbps	115200, n, 8, 1	27 Bytes	370
2.0B 1 Mbps	230400, n, 8, 1	27 Bytes	666
2.0B 1 Mbps	460800, n, 8, 1	27 Bytes	1250

**Accessory**



Optional CAN bus connector: CNT-CAN

Step 1



Step 2

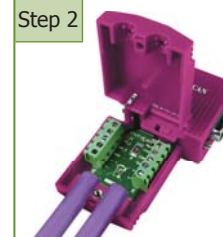

Step 3



Step 4



Installation

## Low-Speed/Fault-Tolerance CAN to RS-232 Converter

### I-7530-FT



The I-7530-FT is a low speed but reliable CAN to RS-232 converter. The "FT" stands for "Fault Tolerance". It follows ISO 11898-3 standard, and is suited for the applications which may have a lot of noise in the harsh environment. Generally, the I-7530-FT communicates with other CAN devices by two-line CAN bus. As one of the CAN bus lines is malfunction, the I-7530-FT even uses a single line of the CAN bus to access the CAN devices. The utility tool supports sending or receiving CAN messages, and the configuration of the I-7530-FT. This tool is free, and is helpful to diagnostic the CAN networks.

- Max. transmission speed of up to 125 kbps for CAN and 115.2 kbps for RS-232
- Power, data flow and error indicator for CAN and RS-232 transmission
- Compatible with CAN specification 2.0 parts A and B
- Fully compatible with the ISO 11898-3 standard
- Built-in CAN/RS-232 converter firmware
- Built-in RS-232/CAN FIFO buffers



## CAN to RS-232/422/485 Converter

### I-7530A



The I-7530A is an RS-232/422/485 to CAN converter. It is a member of the I-7530 serial family, and inherits all of the features of the I-7530. The CAN interface of the I-7530A follows ISO 11898-2 specification, the maximum CAN baud is up to 1 Mbps. There is one COM port in the I-7530A. As the I-7530A runs, it only receives the commands from one of these COM interfaces (i.e. from the RS-232, RS-485 or RS-422 interface) at the same time, but the CAN messages will be forwarded to all of these COM interfaces.

- Provides one channel each for CAN, RS-232, RS-422 and RS-485
- CAN and serial COM parameters can be configured via software
- Jumper for the 120 Ω terminator resistor of the CAN bus
- Supports a range of baud rates from 10 kbps ~ 1 Mbps
- Compatible with CAN specification 2.0 parts A and B
- 2500 Vrms photocoupler isolation on the CAN side
- Fully compatible with the ISO 11898-2 standard
- Supports transparent communication mode
- 3 kV galvanic isolation

### Block Diagram of I-7530A

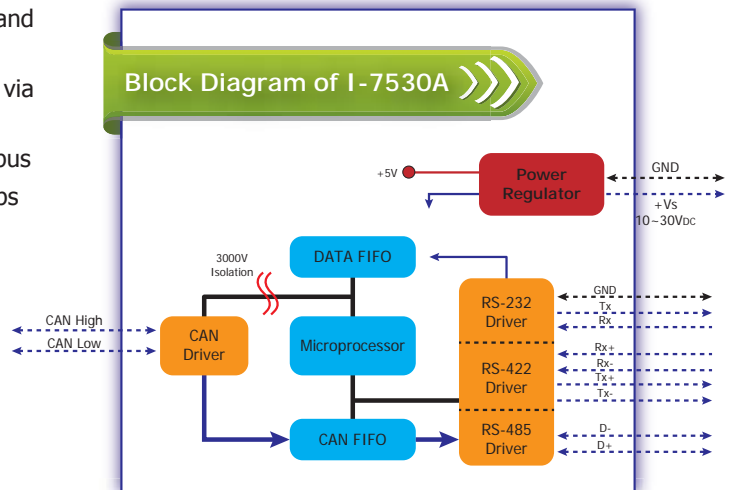

### CAN to RS-232 Converter

#### I-7530



The I-7530 is designed for integrating the traditional RS-232 devices into the CAN network. It is a RS-232 to CAN converter which unleashes the power of the CAN bus via an RS-232 communication interface, converting messages between a CAN network and an RS-232 device. The CAN interface of the I-7530 follows ISO 11898-2 specification, the maximum CAN baud is up to 1 Mbps. Sometimes, users need to control several RS-232 devices at the same time. In this case, the I-7530 provides the station ID for the RS-232 device which is connected with the I-7530. These RS-232 devices can be grouped in a CAN network, and be controlled by one CAN master via setting pair connection mode.

- 3 kV galvanic isolation
- One CAN port and one RS-232 port
- Support transparent communication mode
- Fully compatible with the ISO 11898-2 standard
- 2500 Vrms photocoupler isolation on the CAN side
- Compatible with CAN specification 2.0 parts A and B
- Supports a range of baud rates from 10 kbps ~ 1 Mbps
- Jumper for the 120 Ω terminator resistor of the CAN bus
- CAN and RS-232 parameters can be configured via software

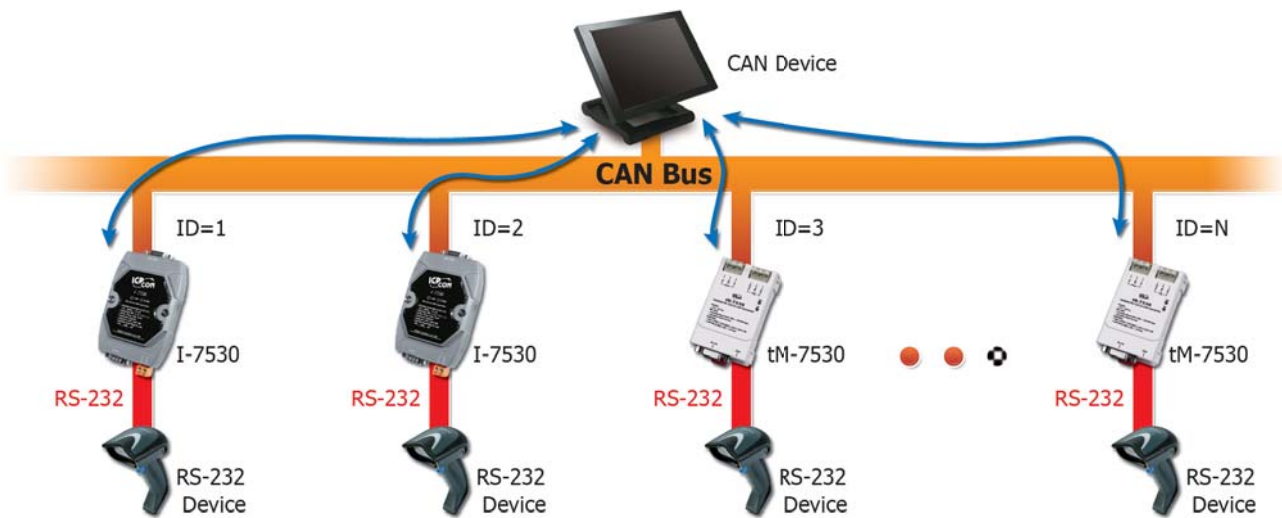

### Tiny CAN to RS-232 Converter

#### tM-7530



The tM-7530 is a tiny form-factor, cost-efficient, and low consumption module. And it is designed for integrating the traditional RS-232 devices into the CAN network. It is a RS-232 to CAN converter which unleashes the power of the CAN bus via an RS-232 communication interface, converting messages between a CAN network and an RS-232 device. The CAN interface of the tM-7530 follows ISO 11898-2 specification, the maximum CAN baud is up to 1 Mbps. The functional design of tM-7530 is the same as I-7530 series, including basic communication and pair connection mode. tM-7530 supports RS-232 baud rate up to 230400 bps.

- Compatible with CAN specification 2.0 parts A and B
- Supports a range of baud rates from 10 kbps ~ 1 Mbps
- Option the 120 Ω terminator resistor of the CAN Bus
- 1 kV galvanic isolation
- Fully compatible with the ISO 11898-2 standard
- 2500 Vrms photocoupler isolation on the CAN side
- One CAN port and one RS-232 port
- Support transparent communication mode
- CAN and RS-232 parameters can be configured via software
- RS-232 baud rate up to 230400



## CAN to Modbus RTU Slave Converter

### I-7530A-MR



The I-7530A-MR is a CAN bus to Modbus RTU converter and it allows a Modbus RTU master to communicate with CAN devices on a CAN network. Different from the I-7530A, the I-7530A-MR can be a Modbus RTU slave, and it is more suitable for connecting with the PLC, HMI or SCADA which provide the functions of the Modbus RTU master. Besides, the higher COM baud and full-duplex RS-232/RS-422 transparent communication of the I-7530A-MR solve more difficult problems of applications which may not be touched by the I-7530A. The I-7530A-MR provides three kinds of communication modes, ASCII communication mode, Modbus RTU communication mode, and transparent communication mode.

- Compatible with CAN specification 2.0 parts A and B
- Supports CAN bus acceptance filter configuration
- Converts CAN messages to specific ASCII command string
- Provides pair-connection communication between RS-232/RS-485/RS-422 devices via the CAN bus
- Supports Modbus RTU function codes 0x03/0x04/0x10 for reading/writing CAN messages
- Programmable CAN bus baud rate from 10 kbps ~ 1 Mbps, or a user-defined baud rate
- Include a software utility that enables users to easily configure module settings and test CAN bus communication

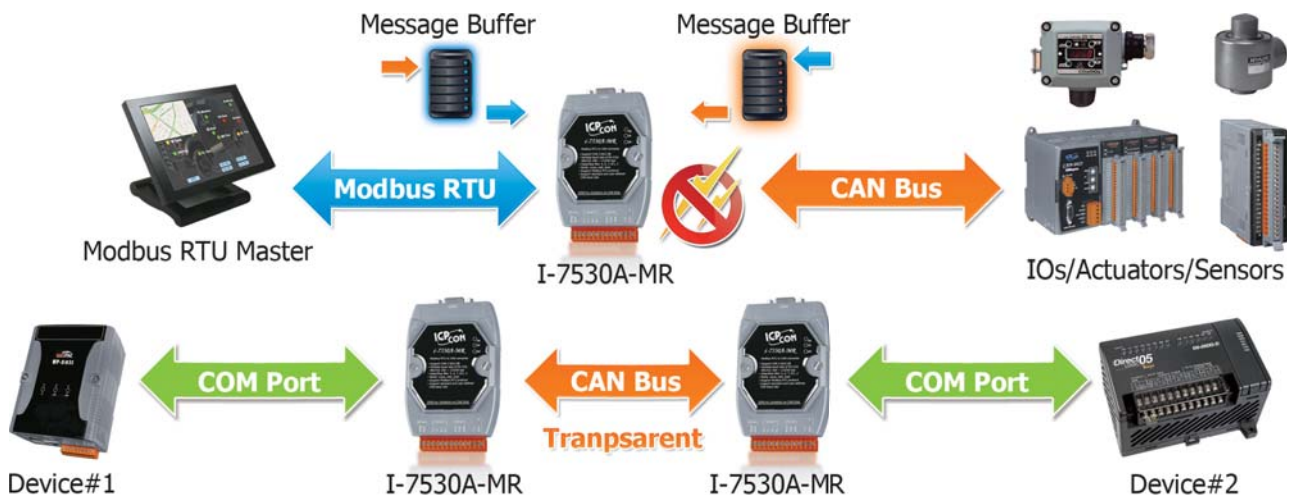
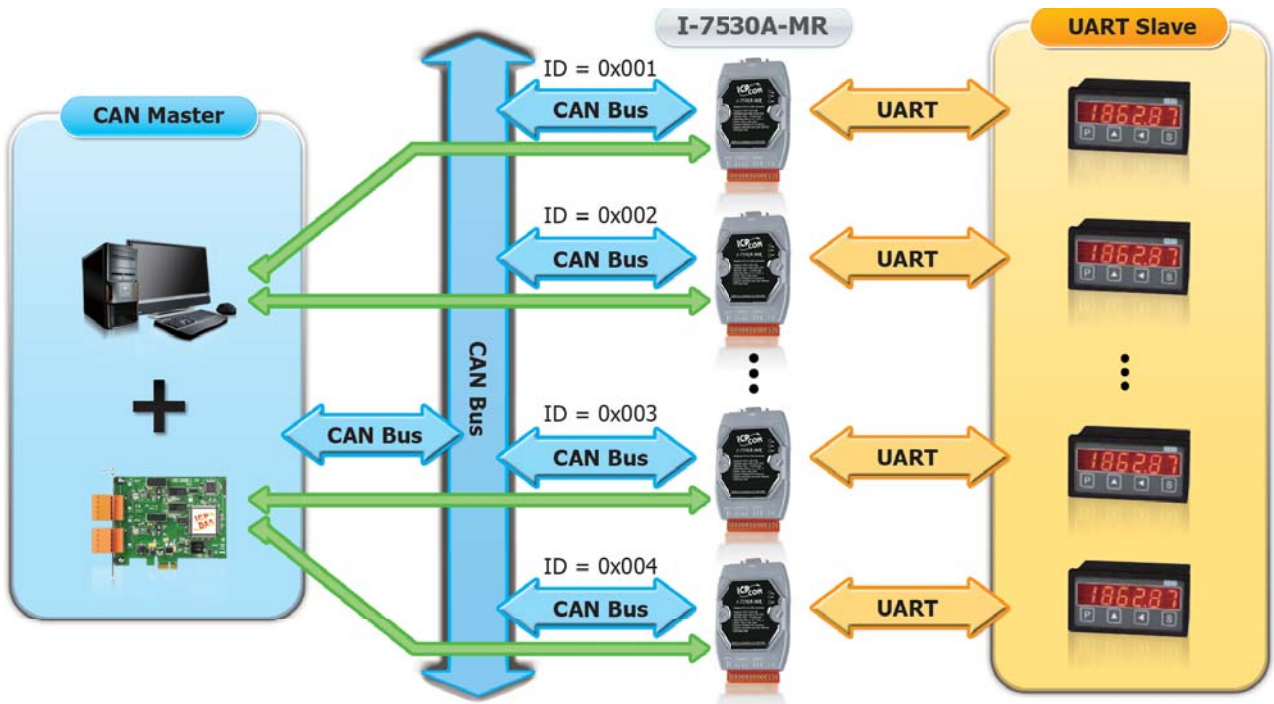

## 4.4 Gateway/Protocol Converters

The stand-alone industrial gateways are designed to connect existing devices to the fieldbus via the serial bus or the Ethernet. Easy to use and setup, no programming required. Following protocols are supported by ICP DAS gateways

- **Modbus RTU:** a kind of protocol based on the RS-232/485 network. The Modbus RTU devices may be a PLC, a Modbus RTU sensor, ICPDAS M-7000 series modules and so forth.
- **Modbus TCP:** a kind of protocol based on the Ethernet. The Modbus TCP devices may be a PLC, a Modbus TCP sensor, ICPDAS ET-7000 series modules and so forth.

### 4.4.1 CANopen Gateways

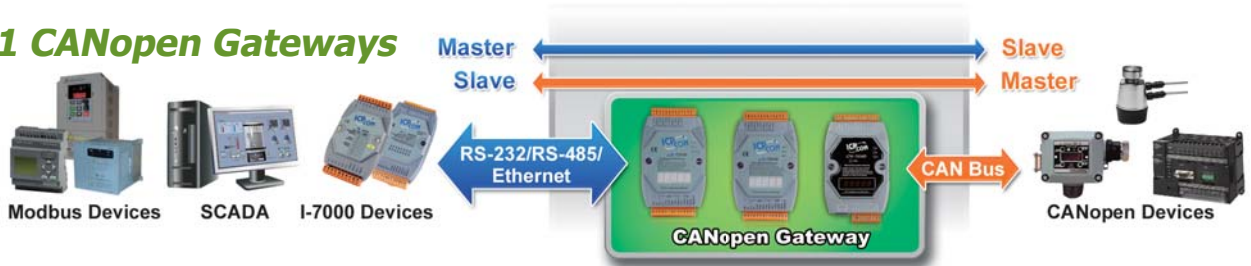

Model Name	I-7232D	GW-7433D	GW-7553-CPM
	CANopen Slave to Modbus RTU Master Gateway	Modbus TCP/RTU Slave to CANopen Master Gateway	PROFIBUS DP Slave to CANopen Gateway
Pictures			<i>Available Soon</i>
<b>CANopen Interface</b>			
CANopen Interface	1 channel (CAN_H, CAN_L), and the other is for bypass		
CANopen Function	CANopen slave	CANopen master (Supports at least 120 CANopen commands)	CANopen master
CANopen Baud Rate	10 k, 20 k, 50 k, 125 k, 250 kbps, 500 k, 800 k, 1M		
CANopen Version	CiA 301 v 4.02 and CiA 401 v2.01		
Guarding Function	Yes		
Heartbeat Function	Heartbeat Producer	Heartbeat Consumer	
Emergency Message	Yes	-	-
<b>UART Interface</b>			
COM1 Connector	RS-232 (TxD, RxD, RTS, CTS, GND) or RS-485 (Data+, Data-), non-isolated	RS-232 (TxD, RxD, RTS, CTS, GND), non-isolated	
COM1 Function	Only for configuration	Modbus RTU Slave	Only for Configuration
COM2 Connector	RS-485 (Data+, Data-) with internal self-tuner ASIC; non-isolated		-
COM2 Function	Modbus RTU Master (Supports Max. 10 Modbus RTU commands)	Modbus RTU Slave	-
<b>Ethernet Interface</b>			
Ethernet	-	10/100 Base-TX	-
Ethernet Function	-	Configuration or Modbus TCP Server	-
Modbus Function Code	01, 02, 03, 04, 06, 15	01, 02, 03, 04, 05, 06, 15,16	-
<b>PROFIBUS Interface</b>			
Connector	-	-	9-pin female D-Sub
Baud Rate (bps)	-	-	9.6 k, 19.2 k, 45.45 k, 93.75 k, 187.5 k, 500 k, 1.5 M, 3 M, 6 M, 12 M
Transmission Distance (m)	-	-	Depend on baud rate (for example, max. 1200 m at 9.6 kbps )
Protocol	-	-	DP-V0 Slave
Max. Input/Output Length	-	-	240/240 bytes
<b>System</b>			
Power Consumption	3 W		
Power Input	10 ~ 30 VDC		
Dimension (W x L x H)	72 mm x 122 mm x 33 mm		
Operating Temperature	-25 ~ +75°C		
Storage Temperature	-30 ~ +80°C		

## CANopen Slave to Modbus RTU Master Gateway

### I-7232D



The I-7232D is a CANopen slave to Modbus RTU master gateway, and allows a CANopen master to have ability to access the Modbus slave devices. In the CANopen network, the I-7232D is a NMT slave, SDO server, PDO producer, and PDO consumer. From the view of the Modbus network, it is a Modbus RTU master which polls all the predefined data of the Modbus RTU slaves, and bypass the CANopen control commands to the Modbus slaves. The I-7232D follows the CANopen specification CiA-301 v4.02 and CiA-401 v2.1, and supplies many features of CANopen protocols, such as dynamic PDO, EMCY object, error output value, SYNC cyclic and acyclic. Like the I-7231D, the EDS file is also provided by the utility tool. Users can easily apply the I-7232D in the standard CANopen master with the EDS file.

- PDO: Event-triggered, RTR, cyclic, acyclic SYNC and dynamic PDO mapping
- CANopen Version: DS-301 v4.02 , DSP-401 v2.1
- Support Max. 10 Modbus RTU commands
- Error Control: Node Guarding protocol
- Product EDS file dynamically by utility
- No of SDOs: 1 server, 0 client
- NMT: Slave

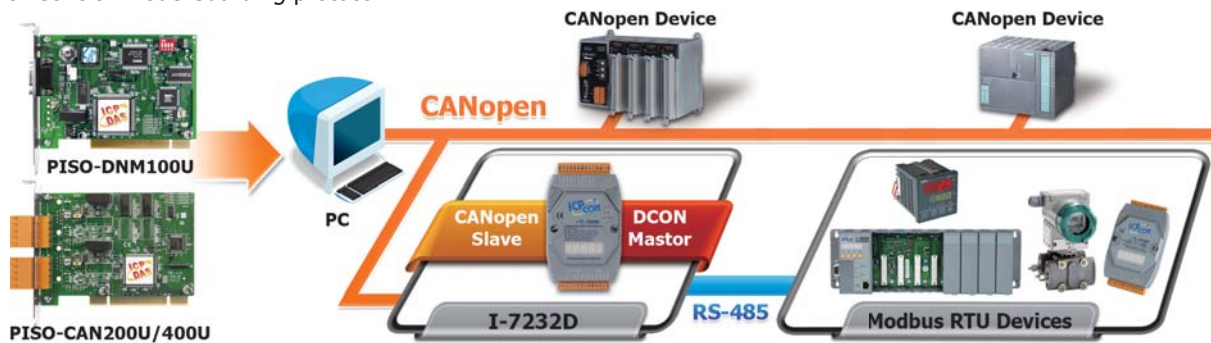

## Modbus TCP/RTU Slave to CANopen Master Gateway

### GW-7433D



The GW-7433D is an economic Fieldbus solution that provides the communication transformation mechanisms between the Modbus protocol and the CANopen protocol. This module is able to collect the information of the CANopen slaves periodically, and returns these data to the Modbus TCP client or Modbus RTU master while receiving the Modbus commands. When the Modbus TCP client or Modbus RTU master needs to output data to the CANopen slaves, the GW-7433D transfers the received Modbus commands to the CANopen messages to handle the CANopen slaves. Both of the Modbus TCP server and the Modbus RTU slave functions can work on the GW-7433D simultaneously. The GW-7433D also offers the Modbus registers for recording the life statuses of the CANopen slaves. These features mean that users can set up their applications more reliably and flexibly.

- Allow 5 Modbus TCP masters to access GW-7433D simultaneously
- Support more than 120 CANopen SDO/PDO commands
- Error Control: Node Guarding protocol
- Configuration by utility via Ethernet
- CANopen Version: DS-301 v4.02
- PDO: Event-triggered, RTR
- Emergency Message: Yes
- NMT: Master

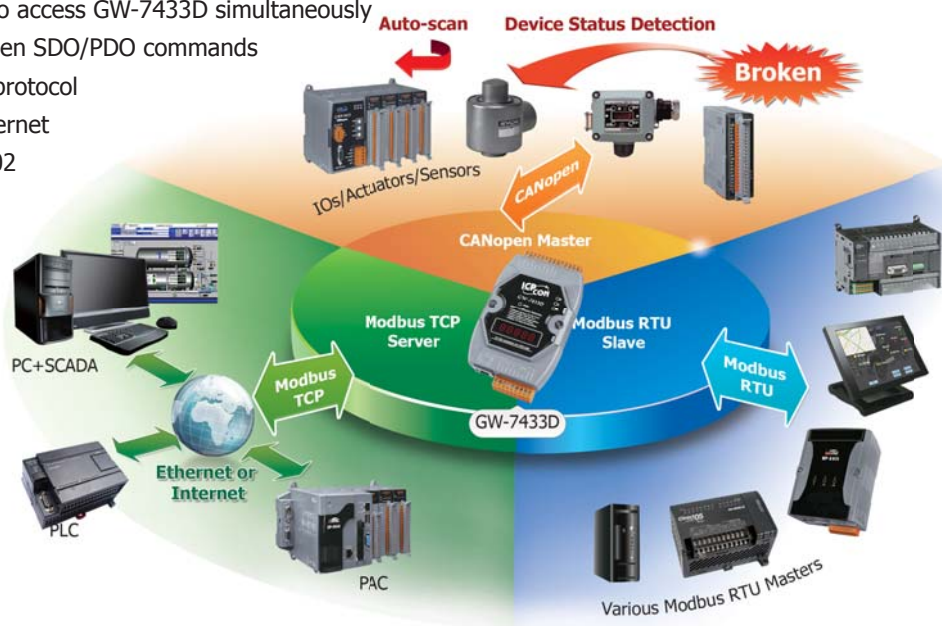

Available soon

## PROFIBUS DP Slave to CANopen Master Gateway

### GW-7553-CPM



The GW-7553-CPM is designed for the slave device of PROFIBUS DP protocol. It allows PROFIBUS master to access CANopen slave devices. These CANopen slave device may be a sensor, actuators, ICPDAS CAN-2000 series modules and so forth. In addition, we also provide the utility software for users to configure the GW-7553-CPM. By using this module, users can put their CANopen slave devices into PROFIBUS network very easily.

- Protocol: PROFIBUS DP-V0 slave
- 240 bytes Max. input data length
- 240 bytes Max. output data length
- Support Heartbeat function
- Support Node Guarding
- PROFIBUS address 0 ~ 126 set by DIP switch
- Follow the CiA CANopen Standard DS-301 v4.02
- Support 110 CANopen SDO/PDO commands
- 3000 VDC isolation protection on PROFIBUS side
- Network isolation protection: 2500 Vrms high speed iCoupler
- Detect Transmission rate (9.6 to 12000 kbps) on PROFIBUS automatically

4

CAN Bus



### Utility Features >>>

- Provide TxPDO, RxPDO, TxSDO, and RxSDO CANopen messages
- Provide Communication Log of CANopen network
- Show PROFIBUS configuration of the gateway
- Provide CANopen test function
- Show diagnostic messages

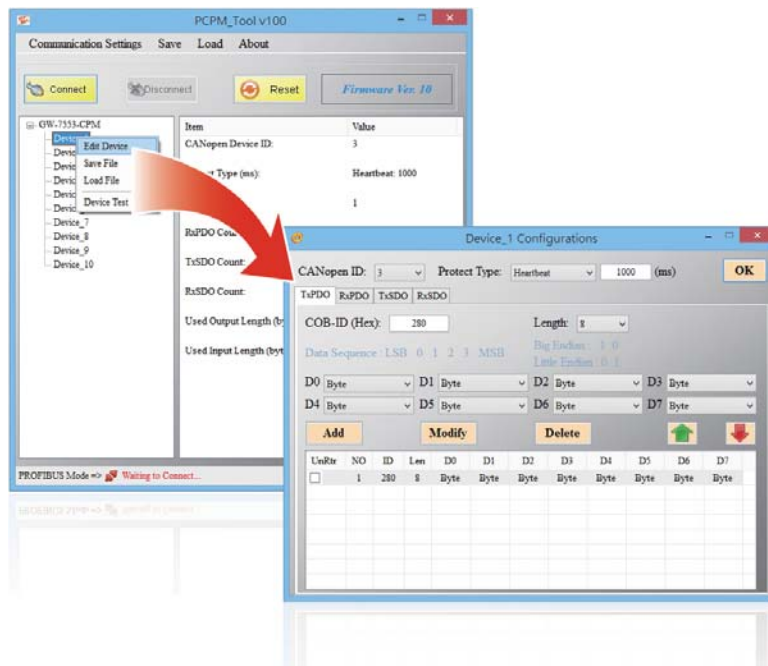

## 4.4.2 CANopen Motion Solution

### Introduction ▶▶▶

The CANopen Motion Library is compliant with the CANopen standard CiA 402, and provides a variety of motion control functions, such as position control, velocity control, torque control, synchronous action etc. The CiA 402 is one of the standard CANopen application profiles, and is specially designed for motion control systems. In addition to making the management of the CANopen-based motors easy, the CANopen protocol, which is based on the CAN bus, can help to reduce the need for wire connections between the controller and the motors, and provides rapid troubleshooting functions. A large number of CANopen-based motors can be linked together so that multi-axis motion control via a single host becomes achievable. While controlling the motors, CANopen-based remote I/O modules that comply with the CiA 402 standard can also be accessed at the same time. Therefore, developing a motion control application becomes easier and more convenient.

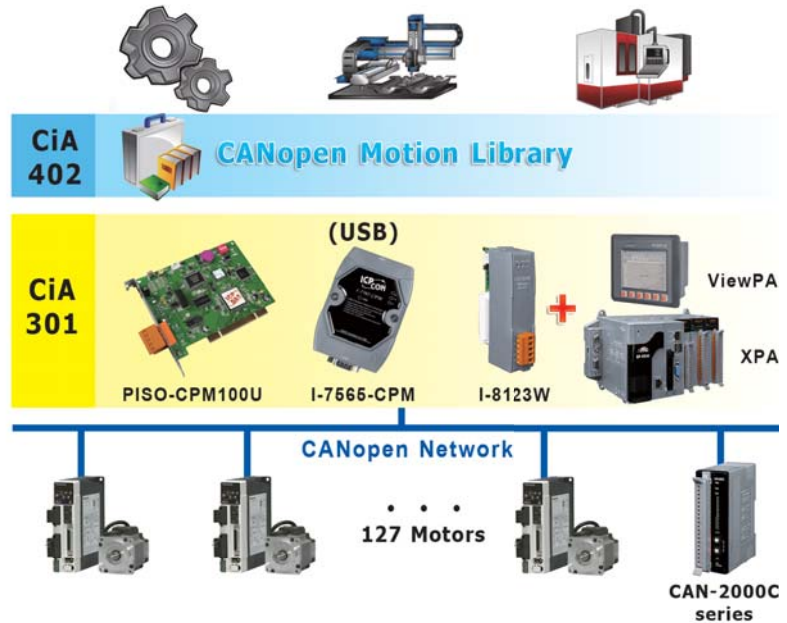

### Features ▶▶▶

- Compliant with the CiA 402 v1.1 Standard
- Supports a max. of 127 motors in a single network
- Absolute and relative position control
- Velocity, torque or jog control
- Supports synchronous action for a maximum of 127 motors
- Supports various homing control methods
- Supports torque limitation via CANopen commands
- Supports the node guarding and heartbeat protocols
- Supports dynamic PDO object configuration
- Bus distance ranges between 25 m to 5000 m
- Supports baud rates of 10 Kbps, 20 Kbps, 50 Kbps, 125 Kbps, 250 Kbps, 500 Kbps, 800 Kbps and 1 Mbps

### Benefits ▶▶▶

- Suitable for distributed multi-axis motion control systems. E.g., distributed sun tracker systems, conveyer transmission control systems, and so on.
- Reduces the cost of wiring, especially time requirements.
- Choose from a range of motors with no limit on certain types.
- The CAN hardware has a range of error detection and error correction mechanisms, which provides the safest communication bus.
- Able to use different CANopen I/O modules and motors in the same CANopen network.
- The range of the CANopen bus can be extended for long distance applications. For example, for solar or wind farm application systems.
- The CANopen bus can be converted to fiber to protect against high noise interference.

### Typical Application Network ▶▶▶



### 4.4.3 DeviceNet Gateways

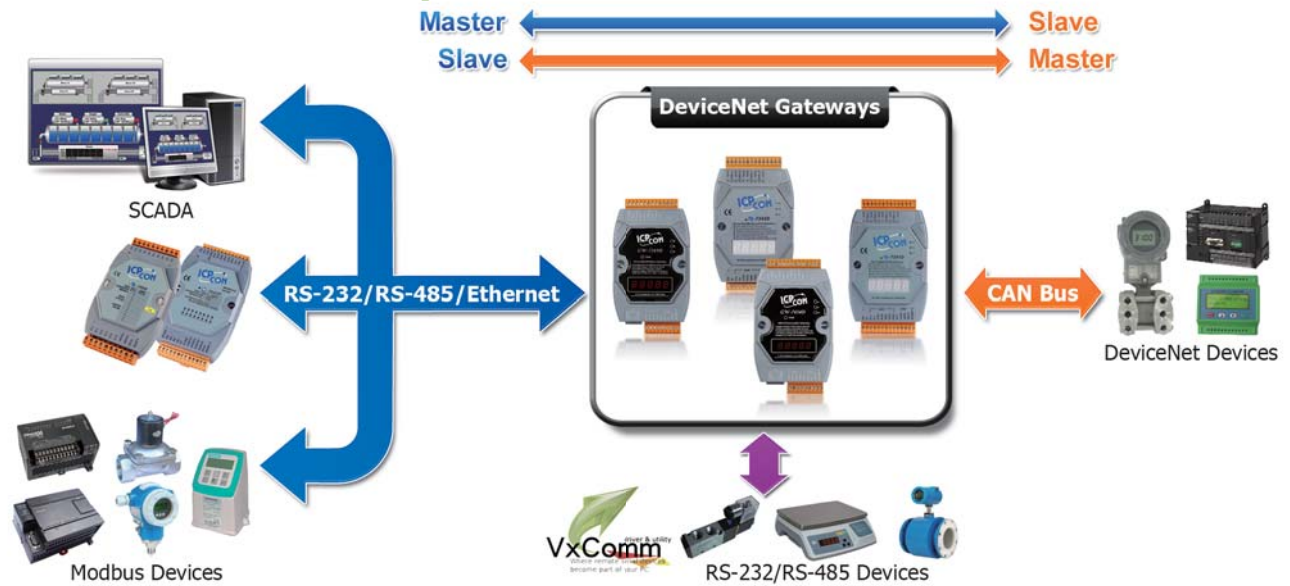

4

CAN Bus

Model Name	I-7242D	GW-7243D	GW-7434D
	DeviceNet Slave to Modbus RTU Master Gateway	DeviceNet Slave to Modbus TCP/RTU Master Gateway	Modbus TCP/RTU Slave to DeviceNet Master Gateway
Pictures			
<b>DeviceNet Interface</b>			
DeviceNet Connector	1 channel (CAN_H, CAN_L), and the other is for bypass		
DeviceNet Function	DeviceNet slave		DeviceNet master
DeviceNet Baud Rate	125k, 250k, 500k bps		
DeviceNet Specification	DeviceNet specification Volume I/II, Release 2.0		
I/O operating modes	Polling, Bit-Strobe, Change of State/Cyclic	Polling	Polling, Bit-Strobe, Change of State/Cyclic
Heartbeat Function	Yes		-
Shutdown Message	Yes		-
Shutdown Message	Yes		-
<b>Shutdown Message</b>			
COM1 Connector	RS-232 (TxD, RxD, RTS, CTS, GND) or RS-485 (Data+, Data-), non-isolated	RS-232 (TxD, RxD, RTS, CTS, GND), non-isolated	
COM1 Function	Only for configuration		Modbus RTU Master/Slave, VxComm
COM2 Connector	RS-485 (Data+, Data-) with internal self-tuner ASIC; non-isolated		
COM2 Function	Modbus RTU Master (Supports Max. 10 Modbus RTU commands)	Modbus RTU/ASCII Master	Modbus RTU Master/Slave, VxComm
<b>Ethernet Interface</b>			
Ethernet	-	10/100 Base-TX (Auto-negotiating, Auto MDI/MDI-X, LED indicators)	
Ethernet Function	-	Modbus TCP Client	Configuration, Modbus TCP Server, VxComm
Modbus Function Code	0x01, 0x 02, 0x 03, 0x04, 0x0F, 0x10	0x01, 0x 02, 0x 03, 0x04, 0x05, 0x06, 0x0F, 0x10	
<b>System</b>			
WDT	Yes (0.8 second)		
Power Consumption	3 W	2.5 W	
Power Input	10 ~ 30 Vdc		
Dimension (W x L x H)	72 mm x 122 mm x 33 mm		
Operating Temperature	-25 ~ +75°C		
Storage Temperature	-30 ~ +80°C		

## DeviceNet Slave to Modbus RTU Master Gateway

### I-7242D



The I-7242D allows a master located on a DeviceNet network to enter into a dialogue with the slaves on a Modbus RTU network. It's a "Group 2 Only Slave" device in the DeviceNet network, and supports "Predefined Master/Slave Connection Set". From the view of the Modbus network, it is a Modbus RTU master which polling all the predefined data of the Modbus RTU slaves, and bypass the DeviceNet control commands to the Modbus slaves. This device is widely used in the application of building automation, remote data acquisition, environment control and monitoring, laboratory equipment & research, factory automation, etc. The I-7242D also has the utility tool which is used to configure the I-7242D's parameters and build the EDS file. Through the EDS file to the I-7241D, it is easy to apply the Modbus RTU devices in DeviceNet applications.

- I/O operating modes: Polling, Bit-Strobe, Change of State/Cyclic
- Support Max. 10 Modbus RTU series modules
- Support Predefined Master/Slave Connection Set (Group 2 Only Server)
- Provide dynamic Assembly Objects mapping
- Comply with DeviceNet specification volume I, release 2.0 & volume II, release 2.0
- Support Offline Connection Set, Device Heartbeat message and Device Shutdown message

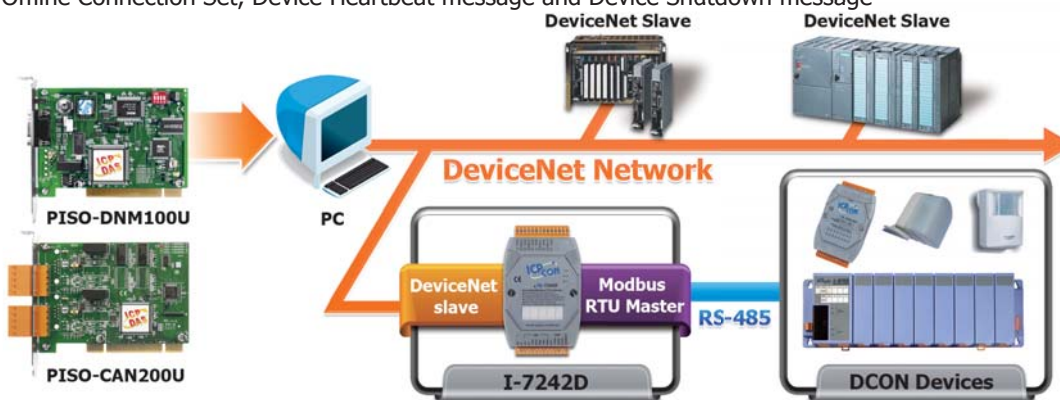

## DeviceNet Slave to Modbus TCP/RTU/ASCII Master Gateway

### GW-7243D



The GW-7243D offers the DeviceNet slave and Modbus master functions, and enables the DeviceNet master to access the Modbus slave devices. In the DeviceNet network, the module acts as a Group 2 Only Server device, and waits to build the connection with the DeviceNet master. In the Modbus network, the GW-7243D is a master device, and cyclically sends the commands to access the Modbus slave devices. Both the Modbus TCP client and Modbus RTU/ASCII master interfaces of the GW-7243D can work simultaneously. This feature means that users are able to integrate different kinds of Modbus slave devices together into the DeviceNet network no matter these devices provide Ethernet, RS-232 or RS-485 communication interfaces. In order to simplify the use of the GW-7243D, the GW-7243D Utility tool for configuration and EDS file production is given. This is helpful to build the applications easily and quickly.

- Group 2 Only Server DeviceNet subscriber
- Support Explicit and Poll Connection
- Maximum support 4 Modbus TCP devices
- Maximum support 5 Modbus TCP commands for each Modbus TCP device
- Maximum support 10 Modbus RTU/ASCII commands for each COM port
- Support Modbus function codes: 0x01, 0x02, 0x03, 0x04, 0x05, 0x06, 0x0F and 0x10

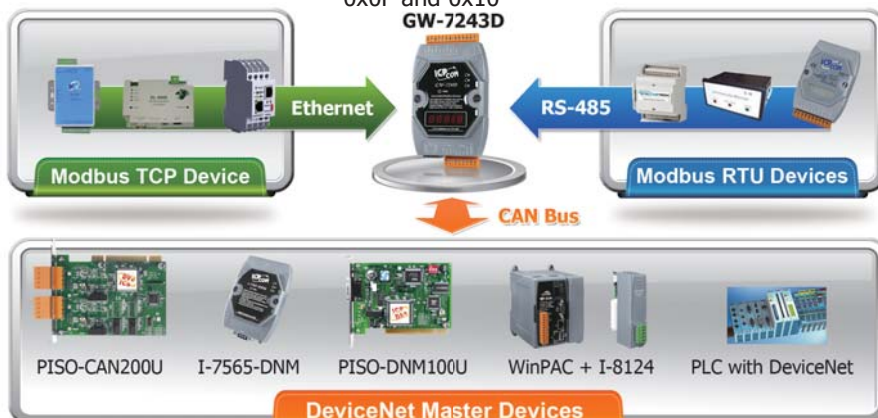

## Modbus TCP/RTU/ASCII Slave to DeviceNet Master Gateway

### GW-7434D



The GW-7434D is an economic solution that provides a communication protocol transformation between the DeviceNet protocol and the Modbus TCP protocol. This module solves the problem to connect an existing DeviceNet network to the Ethernet-based PLC, HMI or SCADA for setting up a control or monitoring system. Different to the GW-7243D, the GW-7434D offers the Predefined Master connection Set function and Group 2 only Server function as a DeviceNet master, and enables accessing the DeviceNet slaves automatically and cyclically. If the PLC, HMI or SCADA would like to access the DeviceNet slaves and simultaneously communicate with the Modbus slaves or COM-based devices connected with the RS-232 or RS-485 ports of the GW-7434D, the GW-7434D can be the Modbus TCP server or VxComm server to exchange the data with those devices.

4

CAN Bus

- Support maximum DeviceNet devices up to 63
- Predefined Master/Slave Connection Set
- Support one Poll, one Bit-Strobe, one COS or one Cyclic IO connection for each DeviceNet device
- Convert single Modbus TCP to multi Modbus RTU devices, setting by Utility
- Support VxComm technique for every COM ports of controllers, setting by Utility
- Programmable DeviceNet Master MAC ID
- Programmable DeviceNet transfer-rate 125K, 250K, 500K
- Supports maximum DeviceNet devices up to 63
- Predefined Master/Slave Connection Set
- DeviceNet I/O Length: 128 bytes max. (Input/Output) per DeviceNet slave
- Total DeviceNet I/O Length: 1280 bytes max. (Input/Output) for all DeviceNet slaves
- Supports I/O Operation Mode: Poll, Bit-Strobe and Change Of State/Cyclic
- Supports maximum 512 bytes Modbus I/O data for DeviceNet I/O to map
- Supports on-line adding device into and removing device from network
- Converts single Modbus/TCP to multi Modbus/RTU, setting by Utility
- Supports VxComm technique for every COM ports of controllers, setting by Utility
- Allowed multi-client (or master) access simultaneously
- Support "Set/Get Explicit Message" methods via Modbus TCP/RTU command
- Supports Modbus RTU to DeviceNet master, setting by Utility

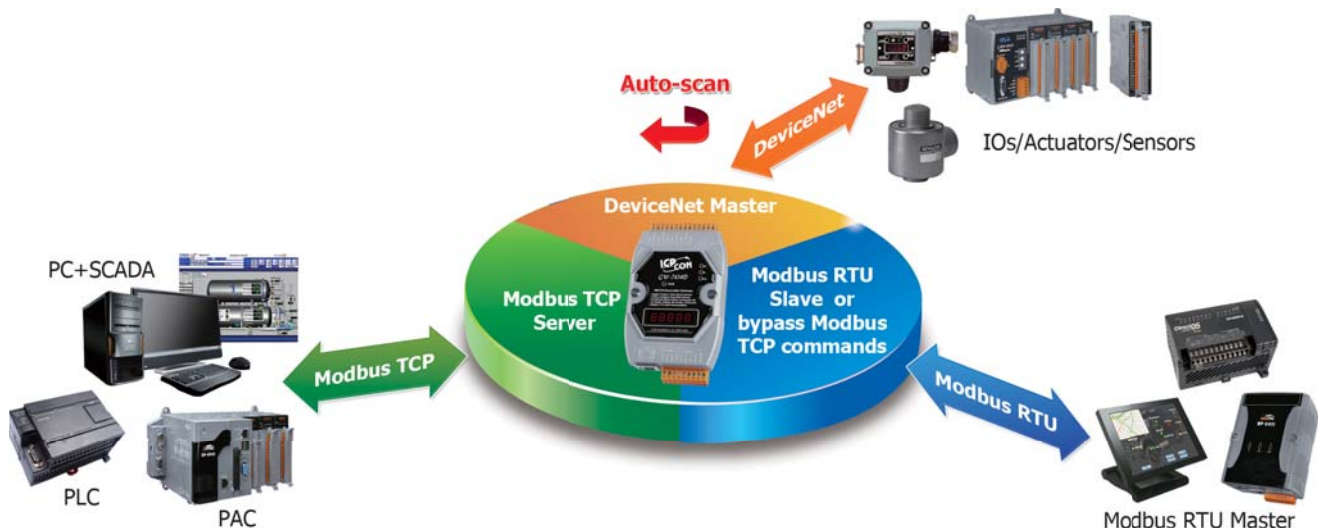



## 4.4.4 J1939 Gateways

J1939 is the vehicle bus standard used for communication and diagnostics among vehicle components, originally by the car and heavy duty truck industry in the United States. Because of the success of applying in vehicles, J1939 has become the accepted industry standard and the vehicle network technology of choice for off-highway machines in applications such as construction, material handling, and forestry machines. It is a higher-layer protocol based on Controller Area Network (CAN), which provides serial data communications between microprocessor systems (ECU) in any kind of heavy duty vehicles. The messages exchanged between these units can be data such as vehicle road speed, torque control message from the transmission to the engine, oil temperature, and many more.



Models	GW-7228	GW-7238D
Pictures		
<b>Hardware</b>		
J1939 Channels	1	
<b>CAN Interface</b>		
Controller	Microprocessor inside with 96 MHz	NXP SJA1000T with 16 MHz clock
Transceiver	NXP 82C250/NXP TJA1042	
Connector	9-pin D-Sub connector	5-pin screwed terminal block (CAN_L, CAN_H, N/A for others)
Baud Rate (bps)	250 k	
Isolation	3000 Vdc for DC-to-DC 2500 Vrms for photo-couple	1000 Vdc for DC-to-DC 2500 Vrms for photo-couple
Terminator Resistor	Selectable 120 Ω terminator resistor by jumper	
Specification/Protocol	ISO-11898-2, CAN 2.0A and CAN 2.0B/J1939	
<b>UART Interface</b>		
COM 1/Protocol	RS-232/RS-422/RS-485/Modbus RTU	RS-232/Modbus RTU
COM 1 Connector	14-pin screw terminal connector RS-232 (TXD, RXD, GND)/ RS-422 (Tx+, Tx-, Rx+, Rx-)/ RS-485 (D+, D-)	5-pin screwed terminal block (TxD, RxD, RTS, CTS, GND)
COM 2/Protocol	–	RS-485 (Self-Turner inside)/Modbus RTU
COM 2 Connector	–	2-pin screwed terminal block (DATA+, DATA-)
<b>Ethernet Interface</b>		
Controller	–	10/100Base-TX Ethernet Controller (Auto-negotiating, Auto_MDIX)
Connector/Protocol	–	RJ-45 with LED indicator/Modbus TCP
<b>Power</b>		
Power Supply	Unregulated +10 VDC ~ +30 VDC	
Protection	Power reverse polarity protection, Over-voltage brown-out protection	
Power Consumption	1.5 W	2 W
<b>Mechanical</b>		
Dimensions (L x W x H)	122 mm x 72 mm x 33 mm	108 mm x 72 mm x 33 mm
<b>Environment</b>		
Operating Temperature	-25°C ~ +75°C	
Storage Temperature	-30°C ~ +80°C	
Relative Humidity	10 ~ 90% RH, Non-condensing	

### Modbus RTU Slave to J1939 Master Gateway

#### GW-7228



The GW-7228 enables the Modbus RTU master to exchange the data with the devices in the J1939 network. This module provides the Modbus slave functions on the RS-232, RS-422, and RS-485 ports so that the Modbus RTU master can easily control and monitor the J1939-based devices. If users use one of the communication ports for application, the other two ports can be used to monitor the Modbus communication situations between the Modbus master and the GW-7228. This feature is helpful for diagnosis while setting up an application system. For J1939 CAN networks, the GW-7228 supports PDU1, PDU2, broadcast and destination specific type of J1939 messages, and is widely applied in the Diesel power-train, in-vehicle networks for trucks and buses or where the Modbus RTU and J1939 protocols transformation is needed.

- Transmission and reception of all types of J1939 messages, including PDU1, PDU2, broadcast and destination specific
- Support Modbus RTU slave protocol with function codes 03, 04, 06 and 16
- Support BAM of Connection Management message
- Built-in jumper to select 120 Ω terminal resistor
- Support RS-232, RS-485 and RS-422 interfaces
- Provide PWR/J1939/MODBUS indication LED

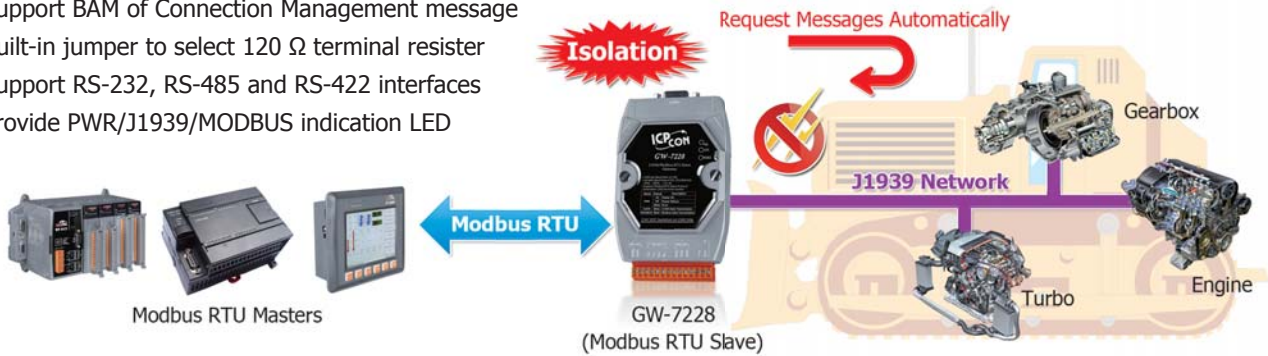

### Modbus TCP/RTU Slave to J1939 Master Gateway

#### GW-7238D



Similar to the GW-7228, the GW-7238D is a J1939 to Modbus master gateway. The main difference is that the GW-7238D has an Ethernet port as the Modbus TCP server, and allows connecting with up to 5 Modbus TCP clients. The GW-7238D also offers an RS-232 and RS-485 ports which are the Modbus RTU slaves and enable the Modbus RTU master to exchange the data with the devices in the J1939 network. Both the Modbus TCP server and the Modbus RTU slave functions of the GW-7238D can work simultaneously. This feature means that users can apply the GW-7238D in their applications more flexibly and more economically. For J1939 CAN networks, the GW-7238 supports PDU1, PDU2, broadcast and destination specific type of J1939 messages, and is widely applied in the various J1939-based applications.

- Transmission and reception of all types of J1939 messages, including PDU1, PDU2, broadcast and destination specific
- Provide PWR/J1939/MODBUS/ERR indication LEDs
- Communication support both Modbus TCP/RTU to J1939 at the same time
- Support RS-232, RS-485 and Ethernet interfaces
- Support Modbus TCP server/RTU slave protocol with function code 03, 04, 06 and 16
- Support BAM of Connection Management message
- Built-in jumper to select 120 Ω terminal resistor

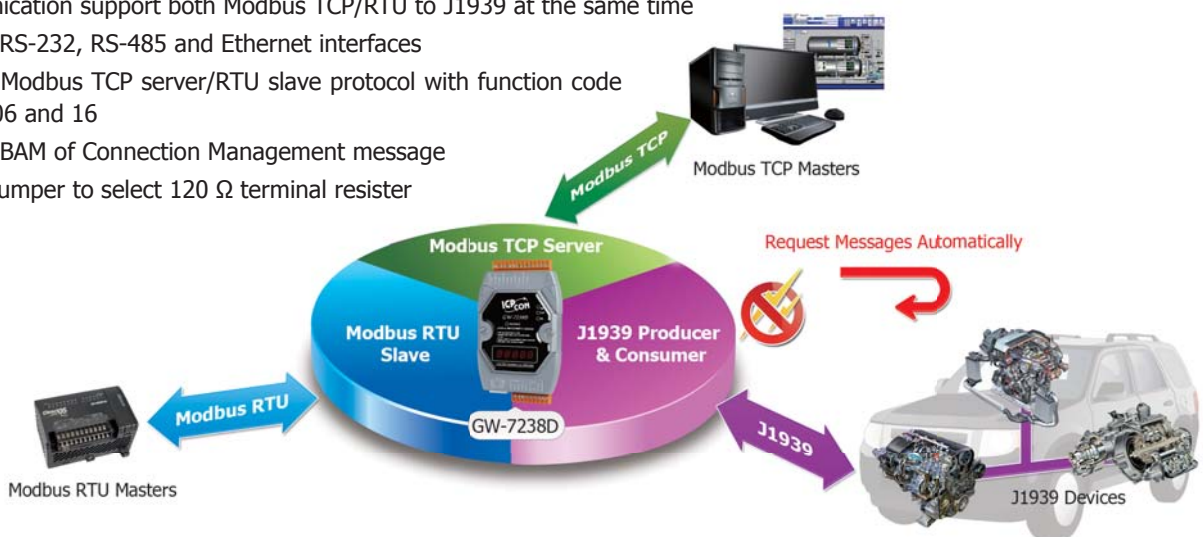

## Case Studies

The user from the vessel power research institute needs to set up an engine test system to adjust the performance of the vessel engines. In this system, the Volvo Penta Diesel engine which offers the J1939 communication interface is used. The user would like to control and monitor the engine parameters, such as the engine oil temperature, the engine coolant temperature, the engine rotational speed, the torque speed and the value of the frequency switch, on the touch screen which provides the RS-485 interface as a Modbus RTU master. In order to overcome the problem of the data exchange between the J1939 network and the Modbus RTU network, the user applies the GW-7228 to resolve this issue. The GW-7228 provides the J1939 interface and the Modbus RTU slave function. In the J1939 network, the GW-7228 listens to the J1939 network and obtains all of the J1939 messages automatically sent from the engine. When receiving the Modbus RTU messages from the touch screen, the GW-7228 returns the data of the engine or commands the engine to change the rotational speed and torque that is corresponding to the content of the Modbus commands.

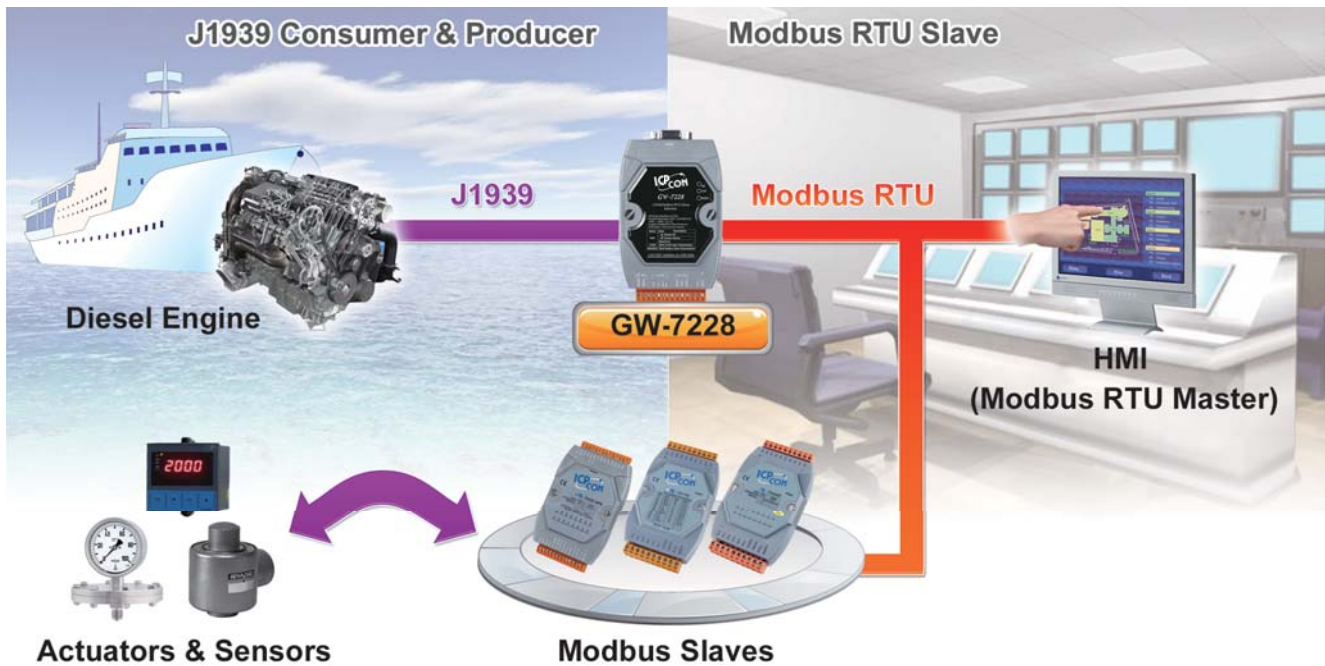

## 4.5 Palm-size Programmable CAN Controllers

The palm size PACs (Programmable Automation Controller) includes I-7188XBD-CAN, uPAC-7186EXD-CAN and uPAC-5001D-CAN2. With abundant and various peripherals and communication ports, the PAC can integrate different communication interface, like CAN bus, RS-232, RS-485, Ethernet and so on. In order to increase the modules openness and applications flexibility, the PAC provides MiniOS7, a DOS-like real-time single-task operation system for adapting to all kinds of needs. Users can develop application programs via C/C++ compiler.

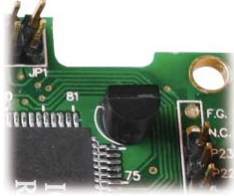

**Unique 64-bit Hardware Serial Number**



**Built-in RTC - Real Time Clock**



**5-Digit 7-Segment LED Display**



**microSD expansion**

Model Name	I-7188XBD-CAN	uPAC-7186EXD-CAN	uPAC-5001D-CAN2
Pictures			
<b>System Software</b>	MiniOS7 (DOS-like embedded operating system)		
<b>Development Software</b>	OS: MiniOS7 (DOS-like embedded operating system) Download Interface: RS-232 (COM1) or Ethernet Language: C language Compilers: TC++ 1.01, TC 2.01, BC++3.1 ~ 5.2x, MSC 6.0, MSVC++ (before version 1.5.2)		
<b>CPU Module</b>	CPU: 80188, 40 MHz or compatible (I-7188XBD-CAN); 80186, 80 MHz or compatible (uPAC-7186EXD-CAN, uPAC-5001D-CAN2) SRAM: 512 KB Flash: 512 KB microSD Expansion: - (I-7188XBD-CAN); Up to 2 GB (uPAC-5001D-CAN2) EEPROM: 2 KB (I-7188XBD-CAN); 16 KB (uPAC-7186EXD-CAN, uPAC-5001D-CAN2) NVRAM: 31 Bytes (battery backup, data valid up to 10 years) RTC (Real Time Clock): Provide second, minute, hour, date, day of week, month, year 64-bit Hardware Serial Number: Yes, for Software Copy Protection Watchdog Timers: Yes (0.8 second)		
<b>Communication Ports</b>	Ethernet: - (I-7188XBD-CAN); 10/100 Base-TX (Auto-negotiating, Auto MDI/MDI-X, LED indicators) (uPAC-7186EXD-CAN, uPAC-5001D-CAN2) COM 1: RS-232 (TxD, RxD, RTS, CTS, GND) or RS-485 (Data+, Data-), non-isolated (I-7188XBD-CAN); RS-232 (TxD, RxD, RTS, CTS, GND), non-isolated (uPAC-7186EXD-CAN, uPAC-5001D-CAN2) COM 2: RS-485 (Data+, Data-) with internal self-tuner ASIC; non-isolated (uPAC-7186EXD-CAN, uPAC-5001D-CAN2) CAN: 1 channel (I-7188XBD-CAN); 1 channel (uPAC-7186EXD-CAN); 2 channels (uPAC-5001D-CAN2)		
<b>LED Indicator</b>	7-Segment LED: Yes Programmable LED Indicators: 4 (I-7188XBD-CAN); 5 (uPAC-7186EXD-CAN, uPAC-5001D-CAN2)		
<b>Mechanical</b>	Dimension (W x L x H): 72 mm x 122 mm x 33 mm (I-7188XBD-CAN); 91 mm x 123 mm x 52 mm (uPAC-7186EXD-CAN, uPAC-5001D-CAN2) Installation: DIN-Rail Mounting		
<b>Environmental</b>	Operating Temperature: -25 ~ +75°C Storage Temperature: -30 ~ +80°C Ambient Relative Humidity: 10 ~ 90% RH (Non-condensing)		
<b>Power</b>	Input Range: 10 ~ 30 VDC (I-7188XBD-CAN); 12 ~ 48 VDC (uPAC-7186EXD-CAN, uPAC-5001D-CAN2) Redundant Power Inputs: - (I-7188XBD-CAN); Yes (uPAC-7186EXD-CAN, uPAC-5001D-CAN2) Power Consumption: 3 W		

## 4.6 PC-based CAN Bus Boards

To access the CAN sensors, actuators, and I/O modules we provide communication boards for PC-based solution.

### Communication Boards:

The following CAN bus communication boards are designed for different interface and different CAN port number.

The common features are:

1. Compatible with CAN specification 2.0 parts A and B
2. Fully compatible with ISO 11898-2 standard
3. Supports baud rate from 10 kbps to 1 Mbps
4. 2 kV galvanic isolated
5. Direct memory mapping to the CAN controller

### Software Support:





#### ► For Windows:

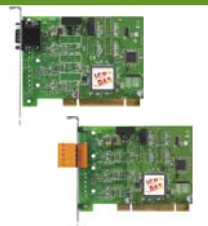

- ✓ LabView CAN Driver
- ✓ DASyLab CAN Driver
- ✓ RTX CAN Driver
- ✓ PISOCNX Active Object
- ✓ NAPOPC.CAN DA Server
- ✓ InduSoft Driver
- ✓ Power Meter Driver

#### ► For Linux:

- ✓ SocketCAN Device Driver

### PC-based CAN Communication Boards

Model Name	PEX-CAN200i	PISO-CAN100U	PISO-CAN200U	PISO-CAN400U	PISO-CAN800U
Pictures					
CAN Channel	2	1	2	4	8
Bus Interface	X1 PCI Express	Universal PCI			
On-board CPU	-				
Baud Rate	Programmable transfer rate up to 1 Mbps				
Terminator Resistor	Jumper for 120 Ω terminator resistor				
Galvanic Isolation	2 kV				
PC APIs	API for VB, VC, BCB, VB.Net, C#.Net				
RTX Driver	Yes				-
LabVIEW Driver	-				Yes
InduSoft Driver	-				Yes
OPC Server	-				Yes
OCX	-				Yes
SocketCAN Driver	Yes				-
Device Driver	Windows XP/7, Linux				Windows XP/7

Model Name	PCM-CAN100	PCM-CAN200	PCM-CAN200P
Pictures			
CAN Channel	1, and the other for bypass	2	
Bus Interface	PCI-104		PC/104-Plus
On-board CPU	-		
Baud Rate	Programmable transfer rate up to 1 Mbps		
Terminator Resistor	Jumper for 120 Ω terminator resistor		
Galvanic Isolation	2 kV		
PC APIs	API for VB, VC, BCB, VB.Net, C#.Net		
RTX Driver	Yes		
LabVIEW Driver	Yes		
InduSoft Driver	Yes		
OPC Server	Yes		
OCX	Yes		
SocketCAN Driver	Yes		
Device Driver	Windows XP/7, Linux		

Model Name	PISO-CM100U	PISO-CM200U	PCM-CM100	PISO-DNM100U	PISO-DNS100U	PISO-CPM100U	PCM-CPM100
Pictures		<i>Available Soon</i> 					
CAN Channel	1	2		1			
Bus Interface	Universal PCI		PCI-104	Universal PCI			PCI-104
On-board CPU	Yes						
On-board CPU OS	MiniOS7	-		MiniOS7			
On-board CPU APIs	C/C++			-			
Default Firmware	CAN 2.0A/2.0B			DeviceNet Master	DeviceNet Slave	CANopen Master	
EDS File Support	-				Yes		
Baud Rate	Programmable transfer rate up to 1 Mbps			125 k, 250 k, and 500 kbps		10 k, 20 k, 50 k, 125 k, 250 k, 500 k, 800 k, 1 Mbps	
Terminator Resistor	Jumper for 120 Ω terminator resistor						
Galvanic Isolation	2 kV						
PC APIs	API for VB, VC++, BCB, Delphi			API for VB, VC++, VB.Net, C#.Net			
LabVIEW Driver	-			Yes	-		
InduSoft Driver	Yes			-		Yes	
Power Meter Driver	Yes			-		Yes	
Device Driver	Windows XP/7, Linux						

### Connector Types: -T/-D

Each CAN bus board provide two type of connectors, i.e. DB9 and Terminal Block.



PISO-xxxxx-D

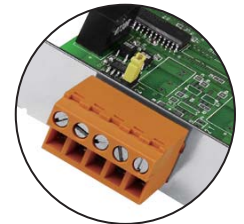

PISO-xxxxx-T

### Accessory:

#### Optional Cable for PISO-CAN800U

##### CA-9-3705:

DB-37 Male (D-sub) to 4-Port DB-9 Male (D-sub) cable. 0.3 M (90°)



##### CA-9-3715D:

DB-37 Male (D-sub) to 4-Port DB-9 Male (D-sub) cable. 1.5 M (180°)



#### Optional CAN bus connector: CNT-CAN

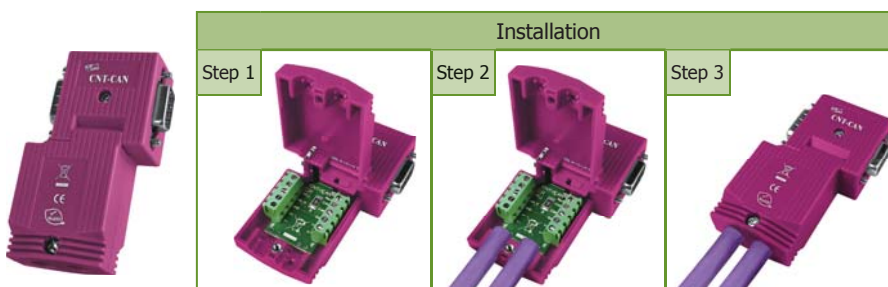

#### CA-0910-C

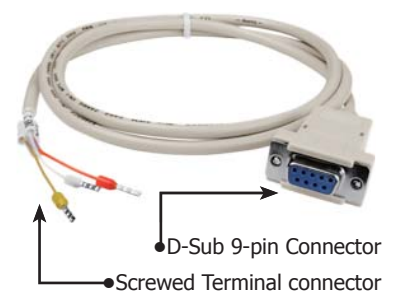

## CAN bus boards

The PCI and PCI Express CAN bus boards use the new CAN controller Phillips SJA1000T and transceiver TJA1042, which provide bus arbitration, error detection with auto correction and re-transmission function. It can be installed in a 5V or 3.3V PCI slot and supported truly "Plug & play".

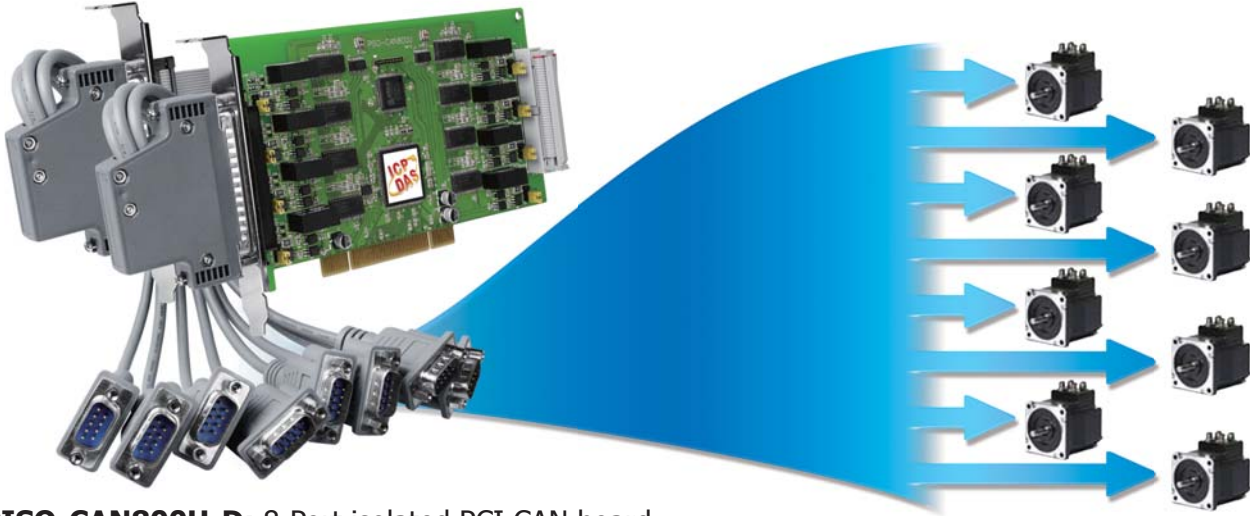

**PISO-CAN800U-D: 8-Port isolated PCI CAN board**

### Features:

- Compatible with CAN specification 2.0 parts A and B
- Support a range of baud rates from 10 kbps ~ 1 Mbps
- 2500 Vrms photocoupler isolation on the CAN side
- VB, VC++, Delphi, and Borland C++ builder demos are provided
- Universal PCI card, supports both the 5 V and the 3.3 V PCI bus
- Built-in jumper for the 120 Ω terminator resistor of the CAN bus
- Fully compatible with the ISO 11898 -2 standard
- Provide 1/2/4/8 independent CAN channels
- 2 kV galvanic isolation for each CAN port
- Direct memory mapping to the CAN controller
- Supports LabVIEW and DASyLab drivers

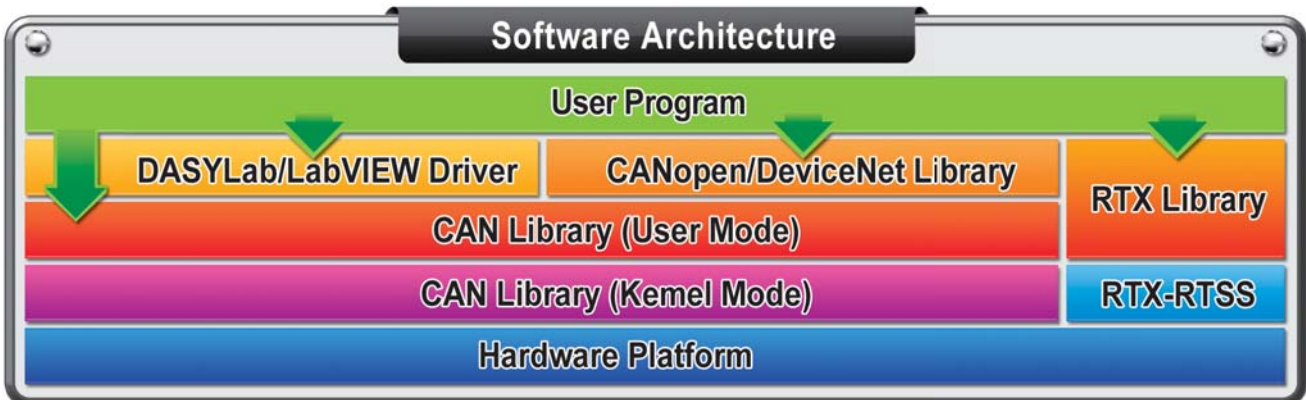
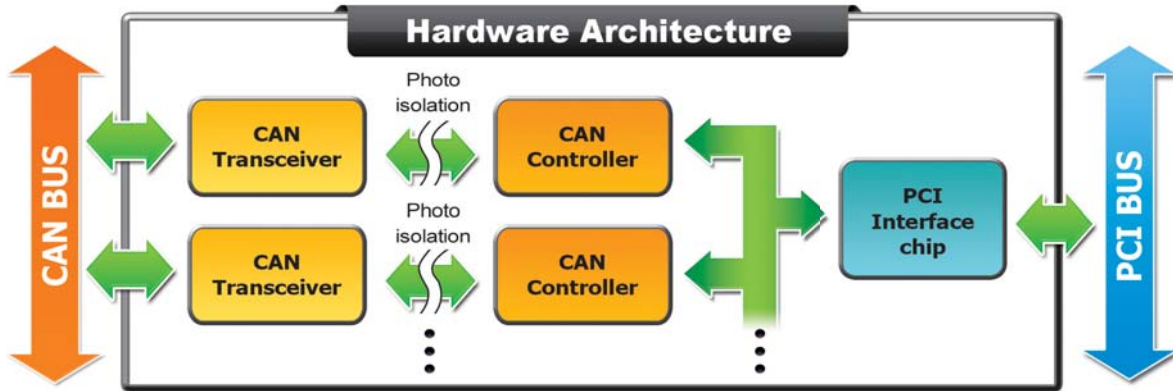

### PISO-CM100U, PCM-CM100: CAN board with built-in programmable CPU

As a stand-alone CAN controller, the PISO-CM100U/PCM-CM100 represents a powerful and economic solution. It has an internal 16-bit 80186 compactable CPU for the complex protocol interpretations and implementations. Owing to the real-time DOS-like OS, MiniOS7, the PISO-CM100U/PCM-CM100 can cover most of all time-critical CAN-based applications, such as self-define CAN protocol, CANopen, DeviceNet, J1939, and so forth. Therefore, when users develop their projects, the PISO-CM100U/PCM-CM100 is helpful to handle the process of the CAN messages, and share the CPU loading of the PC or embedded system. Besides, the PISO-CM100U/PCM-CM100 allows users designing the firmware of the PISO-CM100U/PCM-CM100. Through the library and demos, it is easy to finish the user-defined firmware to satisfy the users' requirements.

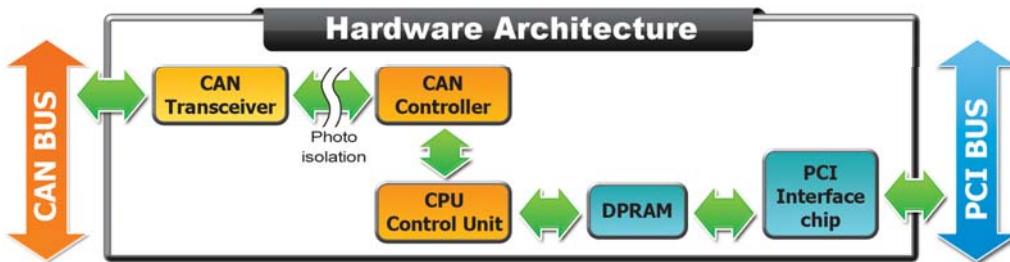
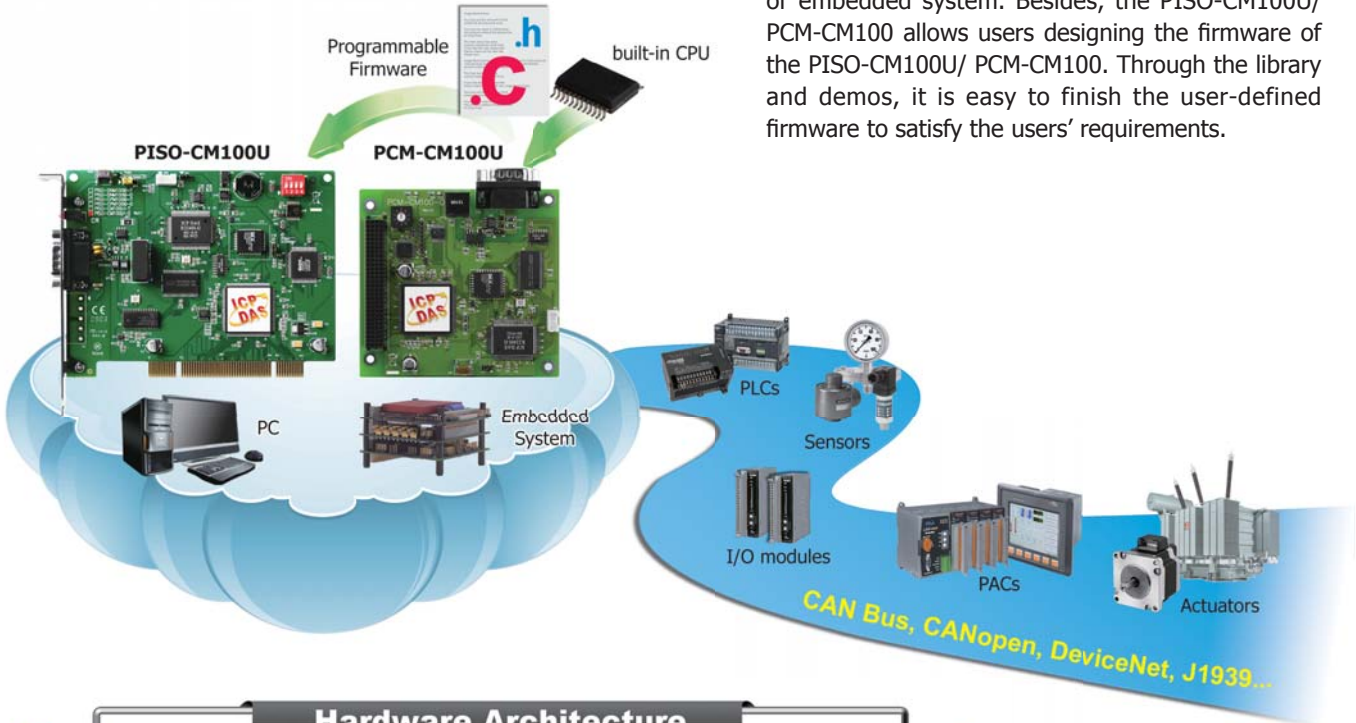

### Built-In CPU Specifications

System Software	
OS	MiniOS7 (DOS-like embedded operating system)
Program Download Interface	RS-232 (needs an optional cable: CA-0904)
Programming Language	C language
Compilers to create.exe Files	TC++ 1.01 TC 2.01 BC++3.1 ~ 5.2x MSC 6.0 MSVC++ (before version 1.5.2)
CPU Module	
CPU	80186, 80 MHz
SRAM	512 KB
Flash	512 KB
EEPROM	16 KB
DPRAM	8 KB
NVRAM	31 Bytes (battery backup, data valid up to 10 years)
RTC (Real Time Clock)	Provides second, minute, hour, date, day of week, month, year
Watchdog Timers	Yes (0.8 second)





## Software



### LabVIEW CAN Driver

The LabVIEW driver includes a configuration utility to configure the ICP DAS's DeviceNet hardware in your PC. By means of this driver, you don't need to Study the complex and abstruse technology of the DeviceNet protocol.

- OS environment: Windows 2000/XP
- Supports NI LabVIEW version 8.0 or later
- Supports CAN specification 2.0A and 2.0B
- Provides 3000-record Rx buffer for each CAN port
- Offers functions for directly accessing SJA1000 register
- Supports time-stamp for each received CAN messages

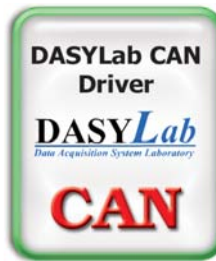

### DASYLab CAN Driver

DASYLab CAN driver makes users interactively develop PC-based applications by simply attaching functional icons. DASYLab offers real-time analysis, control, and the ability to create custom graphical user interfaces. Besides, it can require weeks of training to master. This is useful in some application cases.

- OS environment: Windows 2000/XP
- Supports DASYLab version 8.0
- Follows CAN specification 2.0A and 2.0B
- Supports maximum 64 CAN ports and maximum 4096 block size.
- Provides Intel mode and Motorola mode for remote CAN device
- Offers two kinds of languages, German and English



### PISOCANX ActiveX Object

PISOCANX uses ActiveX technology to simplify the procedure while developing the application by using PISO-CAN series CAN card. The ActiveX object (OCX) can be not only used in general program development environment, but used in the SCADA software which supports the ActiveX technology.

- OS environment: Windows 2000/XP
- Allows polling mode and interrupt mode
- Provides 3000-record Rx buffer for each CAN port
- Supports functions for directly accessing SJA1000 register
- Allows users to read the card No. and relative information
- Supports time-stamp for each received CAN messages

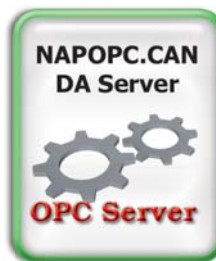

### NAPOPC.CAN DA Server

NAPOPC.CAN DA Server is a CAN OPC server to be as an expert bridge between ICP DAS CAN products and the OPC client of the third party software. Besides, it also provides the easy-to-use integral APIs to access the different CAN ports without through the OPC server.

- OS environment: Windows 2000/XP
- Follows OPC 1.0, OPC 2.0 Data Access Standards
- Configures CAN hardware filter by the APIs of the Virtual CAN Driver
- Provides CAN Engine Utility to monitor the CAN messages
- Collects the data from the different CAN devices in one OPC server
- Provides the CAN devices and the virtual CAN mapping table



### RTX CAN Driver

The RTX CAN Driver helps users to develop the highly real-time CAN bus applications on Windows OS by PISOCAN series boards. The name and parameters of the APIs in the RTX driver are the same as the ones in the Windows driver. Users don't need to pay more efforts to study how to use the APIs of the RTX driver.

- OS environment: Windows2000 SP4, and Windows XP SP2
- Supports interrupt function if the PISO-CAN series CAN card can get the independent IRQ
- Direct I/O control and highly real-time feature
- Supports RTX version 8.0 and RTX 2011
- Provides VC 6.0 demos

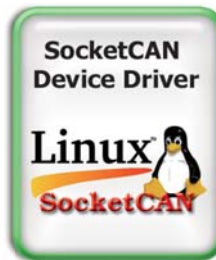

### SocketCAN Device Driver

The SocketCAN driver is a kind of device driver based on the Linux operating system with x86 hardware platform. Users can implement their SocketCAN-based application on the Linux platform by using PISO-CAN series board.

- OS environment: Linux kernel version 2.6.31 ~ 3.2.20 (x86 hardware platform only)
- Provides CANopen/DeviceNet master static library Standard interface for SocketCAN package.
- Supports Virtual CAN interface. Users can map several virtual CAN port into one physical CAN port.
- Provides the RAW socket, CANopen master and DeviceNet master demos



### CANcheck

CANcheck is one software which is used to verify the functions of CAN devices from any manufacturers. It provides users to design the test commands and the expected response. When starting the test, the software will go the predefined procedure to send the messages and check if the responses are correct.

- OS environment: Windows XP, Window 7
- Support: ICP DAS CAN board, CAN converter
- No need to write any programs. The graphical interface is ready-made and easy to operate.
- Can be used to operate and diagnose lights, windows, dashboard or other vehicular electronic systems.
- Supports CAN 2.0A and CAN 2.0B specifications.



### CAN Test Tool

CAN test tool helps users to test the CAN communication of CAN series of ICP DAS. You can use these devices to be an simple CANopen master/slave, DeviceNet master/slave, J1939 transmitter/receiver to test the DUT (device under test).It can easily and quickly test if the DUT works well or not.

- OS environment: Windows XP, Window 7
- Support: ICP DAS CAN board, CAN converter
- Test Function: Two CAN port test to each other, Test with other CAN device, CANopen Master, CANopen Slave, DeviceNet Master, DeviceNet Slave, J1939 Receiver, J1939 Transmitter
- Auto scan all supported ICP DAS CAN device on your PC
- Three steps, easy to test

## 4.7 PAC-based CAN Modules

These CAN bus communication modules are the solutions to the various CAN application requirements in PAC family with rich CAN bus protocols. The I-8123W, I-87123W, I-8124W, and I-87124W separately support CANopen and DeviceNet master protocols. Users can apply them in PAC to connect to CANopen and DeviceNet devices to reach various CANopen/DeviceNet systems easily.

For the especial CAN bus applications, the I-8120W and I-87120W are designed for users to apply in PAC series. The default firmware of I-8120W and I-87120W provides the transmission and reception of CAN bus messages in PAC. In addition, users can design the specific firmware in these modules to reduce the loading of the PAC in C language.

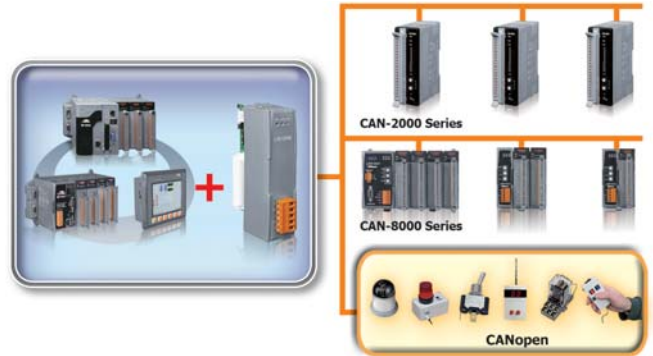

CAN/CANopen/DeviceNet Communication Module (Parallel/Serial Bus)						
Model Name	I-8120W	I-87120	I-8123W	I-87123	I-8124W	I-87124
Pictures						
<b>Communication</b>						
Interface	ISO 11898-2 CAN					
Port	1					
Terminator	120 Ω Selected By Jumper					
Max. Speed (K bps)	1000		1000		500	
Controller Chip	SJA1000T					
Transceiver Chip	82C250					
Protocol	CAN 2.0 A/2.0 B		CANopen CiA 301 ver 4.02, CiA 401 ver 2.1		DeviceNet Volume I ver 2.0, Volume II ver 2.0	
<b>System</b>						
Hot Swap	-	Yes	-	Yes	-	Yes
Data Communication	Parallel Interface	Serial Interface	Parallel Interface	Serial Interface	Parallel Interface	Serial Interface
User-defined Firmware	Yes		-		-	
Isolation	2500 V <sub>rms</sub>					
Power Consumption	2 W					
Connector	5-pin Terminal Block					
Optional Accessories	CA-0904 Cable					
 CA-0904						
Model Name	I-8120W	I-87120	I-8123W	I-87123	I-8124W	I-87124
<b>PAC Driver Support</b>						
I-8000, iP-8000	-	BC, TC	-	BC, TC	-	BC, TC
VP-2111						
WP-8000	eVC++ 4.0, VB.Net 2005, C#.Net 2005					
VP-2000						
XP-8000-CE6, XP-8000-Atom-CE6	VB.Net 2005, C#.Net 2005, VC 2005					
XP-8000, XP-8000-Atom	VB.Net 2005, C#.Net 2005, VC 6					
LP-8000	-	GCC	-	GCC	-	GCC

## 4.8 CAN Bus Power Meter

PM-311x-CPS/CAN series power meter is used for gathering the real-time power consumption information by the CAN interface. It supports not only polling mode, but also Auto-response mode which lets the power meter automatically reply the CAN messages in the predefined time period. This makes the communication more efficient while building a large power monitor system.

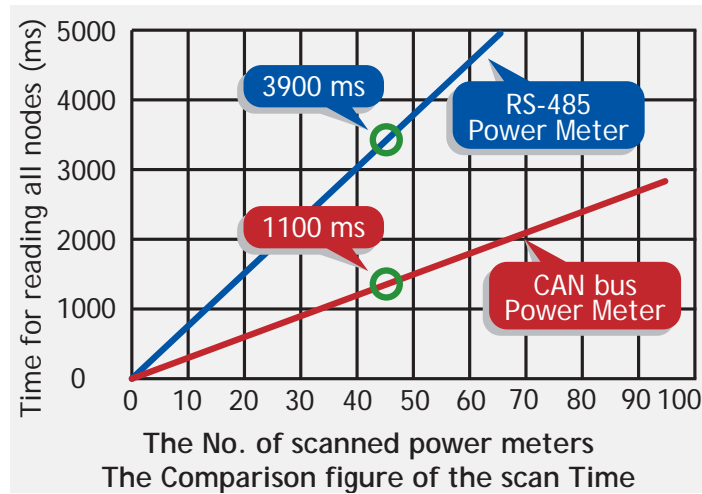

Models	PM-3033-CPS	PM-3133-CPS	PM-3112-CPS	PM-3114-CPS	PM-4324-CPS
Pictures	<b>NEW</b> 	<b>NEW</b> 	<b>NEW</b> 	<b>NEW</b> 	<b>Available Soon</b> 
<b>AC Power Measurement</b>					
Wiring	3P4W-3CT 3P3W-2CT 3P3W-3CT 1P2W-1CT 1P3W-2CT	1P2W-1CT 1P3W-2CT 3P3W-2CT 3P3W-3CT 3P4W	1P2W-2CT	1P4W-4CT	1P2W-1CT 1P3W-2CT 3P3W-2CT 3P3W-3CT 3P4W
Measurement Voltage	10 ~ 500 V		10 ~ 300 V		10 ~ 500 V
Measurement Current	1A or 5A	CTØ10 mm (60 A); CTØ16 mm (100 A); CTØ24 mm (200 A); CTØ36 mm (300 A)			
Measurement Frequency	50/60 Hz				
W Accuracy	Better than 0.5% (PF=1)				
Power Parameter Measurement	True RMS voltage (Vrms), True RMS current (Irms), Active Power (kW), Active Energy (kWh), Apparent Power (kVA), Apparent Energy (kVAh), Reactive Power (kVAR), Reactive Energy (kVARh), Power Factor (PF), Frequency				
Data Update Rate	1 Second				
<b>Alarm Output</b>					
Power Relay	N/A	Form A (Normal Open) x 2; 5 A @ 250 VAC (47 ~ 63 Hz), 5 A @ 30 VDC			
<b>Power</b>					
Input Range	+12 VDC ~ +48 VDC				+90 VAC ~ +240 VAC
Power Consumption	2 W				6 W
<b>Mechanical</b>					
Casing	Plastic				
Module Installation	DIN-Rail Mounting				
<b>Environment</b>					
Operating Temperature	-20°C ~ +70°C				
Storage Temperature	-25°C ~ +80°C				
Ambient Relative Humidity	10 ~ 90% RH, Non-condensing				

## CAN Bus Power Meter

**PM-3033-CPS**



**PM-3112-CPS**



**PM-3133-CPS**



**PM-3114-CPS**



The Smart Power Meter PM-3000 Series can give you access to real-time electric usage for power management. With its high accuracy ( $<1\%$ ,  $PF=1$ ), the power meter series can be applied to both low voltage primary side and/or medium/high voltage secondary side and enables the users to obtain reliable and accurate energy consumption readings from the monitored equipment in real time under operation. These compact size and cost-effective power meters are equipped with revolutionary wired clip-on CT (various types, support input current up to 200 A).

- Current Measurements Up to 200 A with Different CT Ratio
- Supports 2 Power Relay Output (Form A)
- Voltage Measurements Up to 300 V
- W Accuracy Better than 1% ( $PF=1$ )
- Energy Analysis for 1P2W, 1P4W
- True RMS Power Measurements
- Clip-on CT for Easy Installation
- Supports CAN Bus Interface
- Supports CANopen Protocol

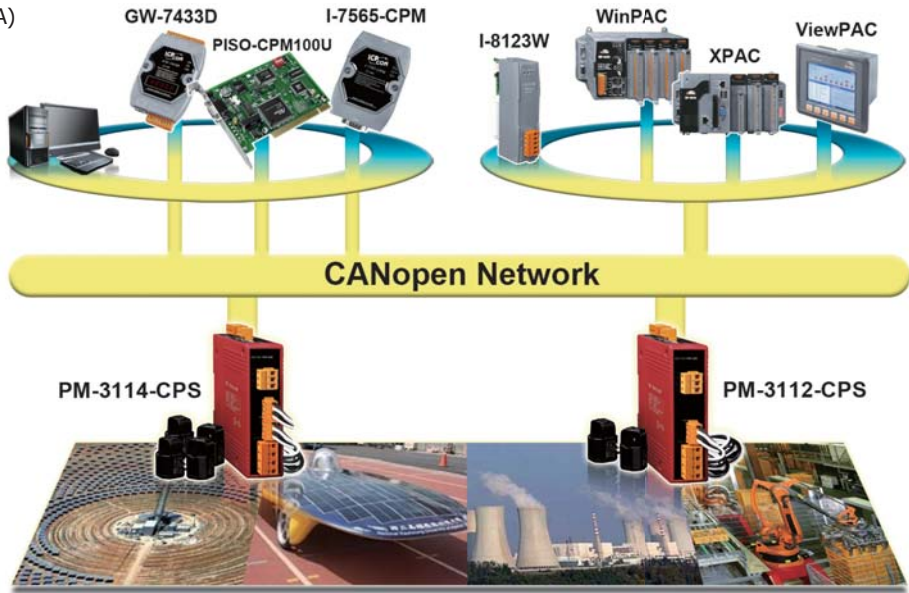

## Case Studies: Power Control System of Factory

## CAN Bus Power Meter

**PM-3114-CPS**



In this case, user add several PM-3114-CPS into existing CANopen network for monitoring power system of factory. The PM-3133-CPS and PM-311x-CPS can be accessed by any standard CANopen master. It makes the communication more efficient when collecting a lot of remote power information.

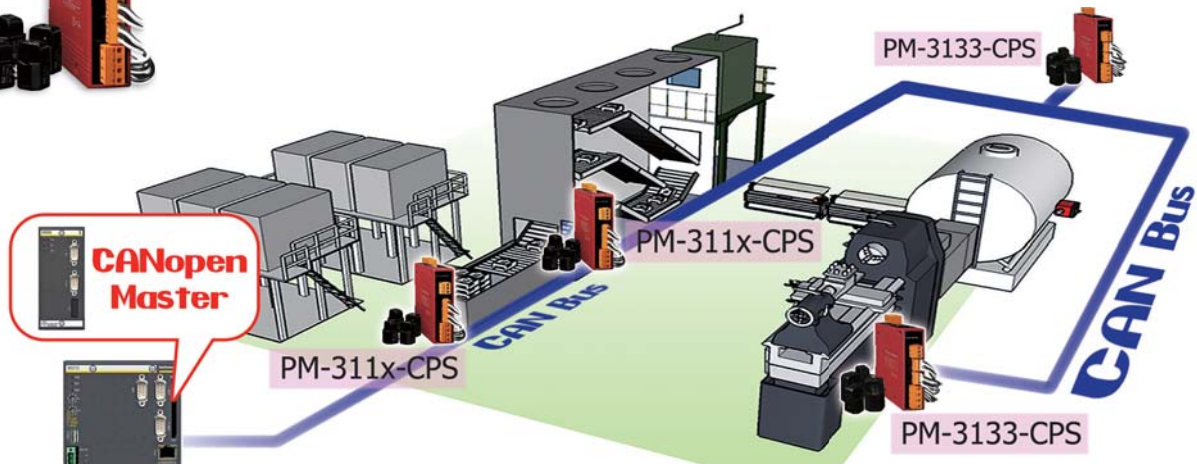

## 4.9 CAN Bus Data Logger

The CAN bus data logging device serves for logging of communication over the CAN data bus. Each received data packet is given a specific time mark, which shows the precise arrival time of data. The actual time mark is obtained from the internal real time clock (RTC), therefore it is independent of the global system time. Data logging on a common SD card allows further analysis and system monitoring on a PC. The CAN-Logger100/200 device by ICP DAS is the result of extensive CAN bus testing and CAN bus programming and is suited for all type of CAN bus application.

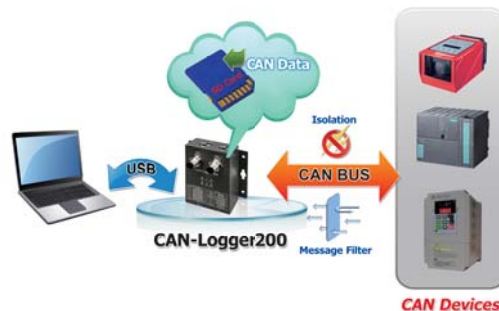

Models	CAN-Logger100	CAN-Logger200
Pictures		
<b>CAN Interface</b>		
Transceiver	NXP TJA1042	
Channel Number	1	2
Connector	5-Pin male M12 x 1 (Pin 1: F.G., Pin 2: +Vs, Pin 3: GND, Pin 4: CAN_H Pin 5: CAN_L)	5-Pin male M12 x 2 (Pin 1: F.G., Pin 2: +Vs, Pin 3: GND, Pin 4: CAN_H Pin 5: CAN_L)
Transmission Speed (bps)	10 k, 20 k, 50 k, 100 k, 125 k, 250 k, 500 k, 800 k, 1 M and user-defined baud rate	
Terminator Resistor	DIP switch for the 120 Ω terminator resistor	
Isolation	3000 VDC for DC-to-DC, 2500 Vrms for photocoupler	
Specification	ISO-11898-2, CAN 2.0A and CAN 2.0B	
CAN Filter	Utility tool	
<b>USB Interface</b>		
Connector	USB Type B x 1	
Compatibility	USB 2.0 High Speed	
Max. Data flow	Transmit: 4000 fps ; Receive: 1000 fps	
Software Driver	Windows 2K/XP/7/8	
<b>Data Logger Capability</b>		
Storage Media	SDHC type flash – support 4 to 32 GB	
Recording Format	Binary	
Time Stamp Resolution	10 us	
Configuration	Utility tool	
Trigger	Log continuously	
Data Logger	Maximum message rate, receive: 15000 msgs/s	
<b>LED</b>		
Round LED	Power, MS, SD, CAN1, CAN2, CAN_ST LEDs	Power, MS, SD, CAN_Rx, CAN_Tx, CAN_ST LEDs
<b>Power</b>		
Power Supply	USB power or CAN bus power (Unregulated +10 ~ +30 VDC) delivery	
Protection	Power reverse polarity protection, Over-voltage brown-out protection	
Power Consumption	0.1 @ 24 VDC	
<b>Mechanical</b>		
Installation	DIN-Rail	
Casing	Metal	
Dimensions (W x L x H)	102.0 mm x 102.0 mm x 44.0 mm (W x L x H)	
<b>Environment</b>		
Operating Temperature	-25°C ~ +75°C	
Storage Temperature	-30°C ~ +80°C	
Relative Humidity	10 ~ 90% RH, Non-condensing	

NEW

## USB to 1-port CAN bus data logger device

### CAN-Logger100



The CAN-Logger100 is a high-performance intelligent CAN bus data logger device with one CAN port that can help to make data collection and to process on a CAN bus network easier and quicker. The powerful CPU of the CAN-Logger100 provides the accurately time-stamp for each CAN message and supports storage media like MMC, SD or SDHC type flash for saving these CAN messages that is useful to analysis and diagnostic the CAN network. In order to enhance the portability of the CAN-Logger100, this module is powered by the USB interface or a M12 connector of CAN bus interface. The CAN-Logger100 uses the standard USB driver of the Windows system. Operating systems supported include Windows 2K/XP/7/8.

- Provides one CAN port
- Power by the USB port or CAN port
- 3 kV galvanic isolation for the CAN port
- Full compatible with the ISO 11898-2 standard
- 2500 Vrms photocoupler isolation on the CAN side
- Supports CAN bus acceptance filter configuration
- Compatible with CAN specification 2.0 parts A and B
- Programmable CAN bus baud rate from 10 kbps ~ 1 Mbps
- Built-in jumper for the 120 Ω terminal resistor of the CAN side
- Supports 4 to 32 GB SDHC type flash for saving CAN messages
- CAN messages are time-stamped with 10 microseconds resolution
- Provides a configuration utility that can be used to transmit/receive CAN messages

NEW

## USB to 2-port CAN bus data logger device

### CAN-Logger200



The CAN-Logger200 is a high-performance intelligent CAN bus data logger device with two CAN port that can help to make data collection and to process on a CAN bus network easier and quicker. The powerful CPU of the CAN-Logger200 provides the accurately time-stamp for each CAN message and supports storage media like MMC, SD or SDHC type flash for saving these CAN messages that is useful to analysis and diagnostic the CAN network. In order to enhance the portability of the CAN-Logger200, this module is powered by the USB interface or M12 connectors of CAN bus interface. The CAN-Logger200 uses the standard USB driver of the Windows system. Operating systems supported include Windows 2K/XP/7/8.

- Provides two CAN port
- Power by the USB port or CAN port
- 3 kV galvanic isolation for the CAN port
- Full compatible with the ISO 11898-2 standard
- Supports CAN bus acceptance filter configuration
- 2500 Vrms photocoupler isolation on the CAN side
- Compatible with CAN specification 2.0 parts A and B
- Programmable CAN bus baud rate from 10 kbps ~ 1 Mbps
- Built-in jumper for the 120 Ω terminal resistor of the CAN side
- Supports 4 to 32 GB SDHC type flash for saving CAN messages
- CAN messages are time-stamped with 10 microseconds resolution
- Provides a configuration utility that can be used to transmit/receive CAN messages



## 4.10 I/O Modules and Units



▲ CAN-2000 series

▲ CAN-8000 series

CAN-2000 series and CAN-8000 series are designed for combining sensors and actuators into CCON, CANopen or DeviceNet network. All of them provide corresponding EDS files for standard CANopen or DeviceNet master interfaces. The main differences between CAN-2000 series and CAN-8000 series are the product size and the capabilities of I/O expansion. CAN-2000 series is a palm-size and stand-alone slave device. It specially suits for distribution control system, and can be placed in a limited space even in the case of machine. CAN-8000 series is useful for centralizing control system. It provides 1/2/4/8 slots for flexible I/O selections to match various applications. Each slot allows you plugging one I-8000/I-87K series I/O module to expand I/O channels, and hot-swap technique is supported.

With the same hardware, the CAN-2000 series and CAN-8000 series can be installed either of CCON, CANopen or DeviceNet firmware. The product names are classified as

**CANopen:** CAN-8x2**3**, CAN-2xxx**C**

**DeviceNet:** CAN-8x2**4**, CAN-2xxx**D**

### Features:

#### 1. Heartbeat Messaging

The heartbeat protocol is generally used to negotiate and monitor the availability of remote I/O devices. It is a message like the heartbeat sent by CANopen/DeviceNet remote I/O modules at a regular time. The users could use this mechanism to indicate the health of the remote I/O. The health information is most important in the industrial applications. All the CANopen/DeviceNet remote I/O series from ICP DAS has the heartbeat protocol to increase the reliability of the remote data.



#### 2. Safety & Arbitration

CAN bus provides five mechanisms for achieving the utmost safety of data transfer. There are powerful for error detection, signaling and self-checking are implemented in every CAN node. If two or more nodes start transmitting messages at the same time, the arbitration mechanism is applied to guarantee that one of these messages can be sent successfully according to the priority.

#### 3. Auto Response of Input Data

The input data of CANopen/DeviceNet I/O modules allows to be responded automatically by event trigger or timer trigger. For example, DI data will be responded to the master when the DI data is changed. The AI data can be responded cyclically by predefined time period.

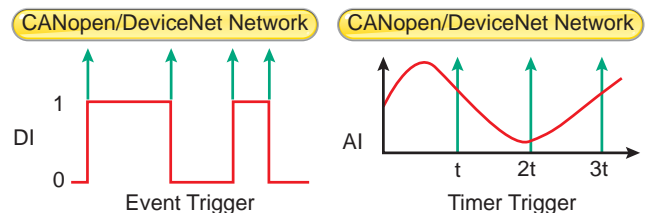

#### 4. CANopen Digital I/O Pair-Connection

CANopen Digital I/O Pair-Connection is a special function for CANopen remote I/O. It can send the DI value that detected by the CANopen DI slave to other CANopen DO slaves through the CANopen network, and then these CANopen DO slaves will output the value. It is useful for users who need to detect a DI signal and output a DO alarm in time.

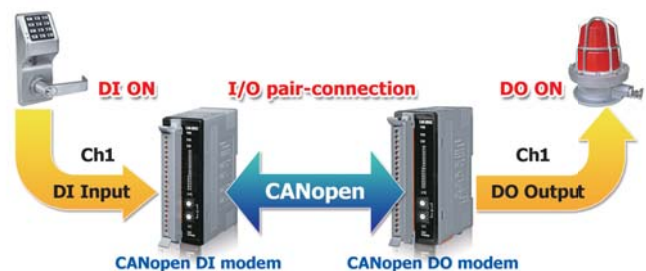

## Communication:

	CANopen I/O Modules	DeviceNet I/O Modules
<b>Communication</b>		
Connector	5-pin screwed terminal block (CAN_GND, CAN_L, CAN_SHLD, CAN_H, CAN_V+)	5-pin screwed terminal block (CAN_GND, CAN_L, CAN_SHLD, CAN_H, CAN_V+)
Baud Rate (bps)	10 k, 20 k, 50 k, 125 k, 250 k, 500 k, 800 k, 1 M	125 k, 250 k, 500 k
Terminator Resistor	Jumper or Switch for 120 Ω terminator resistor	Jumper or Switch for 120 Ω terminator resistor
Node ID	CAN-2000C series: 1 ~ 99 selected by rotary switch CAN-8x23 series: 1~127 selected by rotary switch	0~63 selected by rotary switch
Protocol	CANopen CiA 301 ver4.02, CiA 401 ver2.1	Volume I, Release 2.0 & Volume II, Release 2.0, Errata 5
No. of PDOs	10 Rx, 10 Tx (support dynamic PDO)	-
PDO Mode	Event Triggered, Remotely requested, Cyclic and acyclic SYNC	-
Error Control	Node Guarding protocol and Heartbeat Producer protocol	-
Emergency Message	Yes	-
DeviceNet subscribe	-	Group 2 Only Server
Explicit Connection	-	Yes
Polled I/O Connection	-	Yes
Bit-Strobe I/O Connection	-	Yes
Heartbeat message	Yes	Yes
Shutdown message	-	Yes

## Hardware :

### 1. Installation



### 2. Appearance

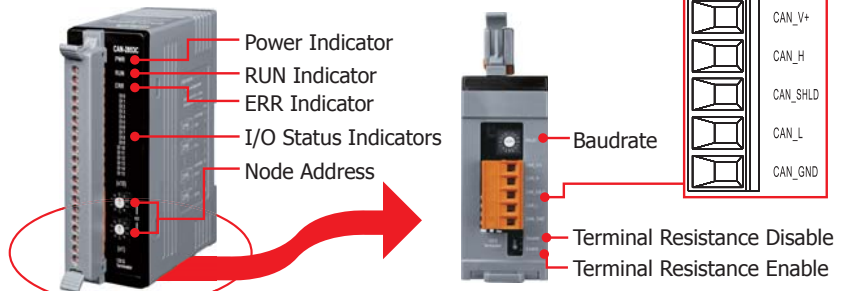

### 3. Dimensions (Units: mm)

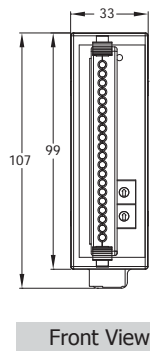
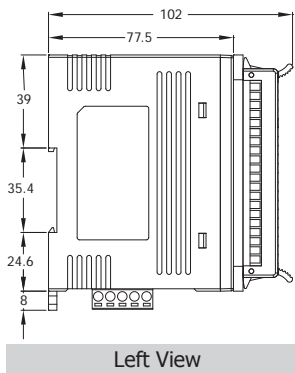

### CAN-8423

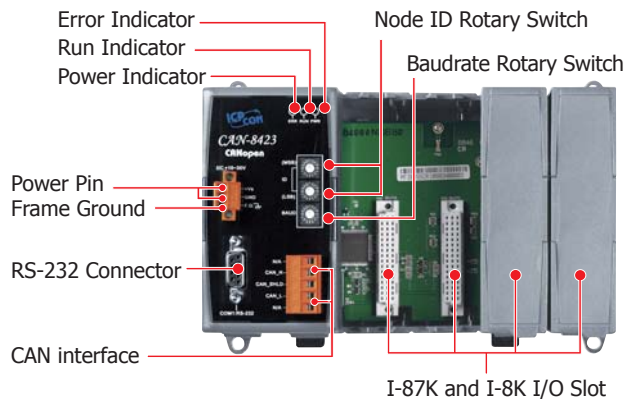

### 4. Optional Accessory





## 4.10.1 Analog Input Modules

### RTD Introduction ▶▶

Resistance Temperature Detectors (RTD), as the name implies, are sensors used to measure temperature by correlating the resistance of the RTD element with temperature. Most RTD elements consist of a length of fine coiled wire wrapped around a ceramic or glass core. The element is usually quite fragile, so it is often placed inside a sheathed probe to protect it. The RTD element is made from a pure material whose resistance at various temperatures has been documented. RTDs are also relatively immune to electrical noise and therefore well suited for temperature measurement in industrial environments, especially around motors, generators and other high voltage equipments.







### Thermocouple Introduction ▶▶

A thermocouple is a temperature sensor which consists of two wires of different conductors.

Based on the Seebeck effect in thermoelectricity, the temperature difference results voltage difference on the two wires.

Thermocouples are widely used in scientific and industrial applications because they're generally accurate and can operate over wide range of temperature.



Model Name	CANopen	CAN-2015C		CAN-2017C		CAN-2018C		CAN-2019C	
	DeviceNet	Available soon	CAN-2015D	CAN-2017D		CAN-2018D		Available soon	CAN-2019D
Pictures		8-Ch RTD Input Module		8-Ch AI Module		8-Ch Thermocouple Input Module		10-ch Universal AI Module	
									
<b>AI</b>									
Channels		8		8		8		10	
Wiring		2/3 wire		Differential		Differential		Differential	
Individual Channel		Yes		Yes		Yes		Yes	
Sensor Type		<b>RTD</b> (Pt100, Pt1000, Ni120, Cu100, Cu1000, JPT100)		-		<b>Thermocouple</b> (J, K, T, E, R, S, B, N, C)		<b>Thermocouple</b> (J, K, T, E, R, S, B, N, C)	
Voltage Input Range		-		±10 V, ±5 V, ±1 V ±500 mV, ±150 mV		±2.5 V, ±1 V, ±500 mV ±100 mV, ±50 mV, ±15 mV		±10 V, ±5V, ±2.5 V ±1 V, ±500 mV, ±100 mV ±50 mV, ±15 mV	
Current Input Range		-		±20 mA (Required External 125Ω Resistor)		±20 mA (Required External 125Ω Resistor)		±20 mA (Required External 125Ω Resistor)	
Resolution		16-bit		16-bit		16-bit		16-bit	
Sampling Rate		10 Hz		10 Hz		10 Hz		10 Hz	
Accuracy		±0.05 % of FSR		±0.1 % of FSR		±0.1 % of FSR		±0.1 % of FSR	
Zero Drift		±0.5 μV/ °C		±10 μV/ °C		±10 μV/ °C		±10 μV/ °C	
Span Drift		±20 μV/ °C		±25 μV/ °C		±25 μV/ °C		±25 μV/ °C	
Overvoltage Protection		120 VDC / 110 VAC		240 Vrms		240 Vrms		240 Vrms	
Input Impedance		20 MΩ		2 MΩ		400 kΩ		400 kΩ	
Common Mode Rejection		150 dB		86 dB		86 dB		86 dB	
Normal Mode Rejection		100 dB		100 dB		100 dB		100 dB	
<b>System</b>									
ESD Protection		4 kV Contact for each channel							
Isolation		3000 VDC for DC-to-DC, 3000 Vrms for bus-to-logic							
Watchdog		Yes							
<b>Power</b>									
Input range		Unregulated +10 ~ +30 VDC							
Power Consumption		1.5 W		2 W		1.5 W		1.5 W	
<b>Mechanism</b>									
Installation		DIN-Rail							
Dimensions (W x L x H)		33 mm x 107 mm x 102 mm						33 mm x 99 mm x 78 mm	
<b>Environment</b>									
Operating Temperature		-25 ~ +75°C							
Storage Temperature		-30 ~ +80°C							
Relative Humidity		10 ~ 90% RH, Non-condensing							

### 4.10.2 Analog Output Modules

All of the CAN-2000 modules provide the EDS files for the standard CANopen and DeviceNet master. The analog output has various output ranges, i.e.,  $\pm 10\text{ V}$ ,  $\pm 5\text{ V}$ ,  $0\sim 20\text{ mA}$ , etc. Each channel can be individually configured to the same or different output range. It is very convenient for applying the CAN-2000 modules into the CANopen and DeviceNet network.

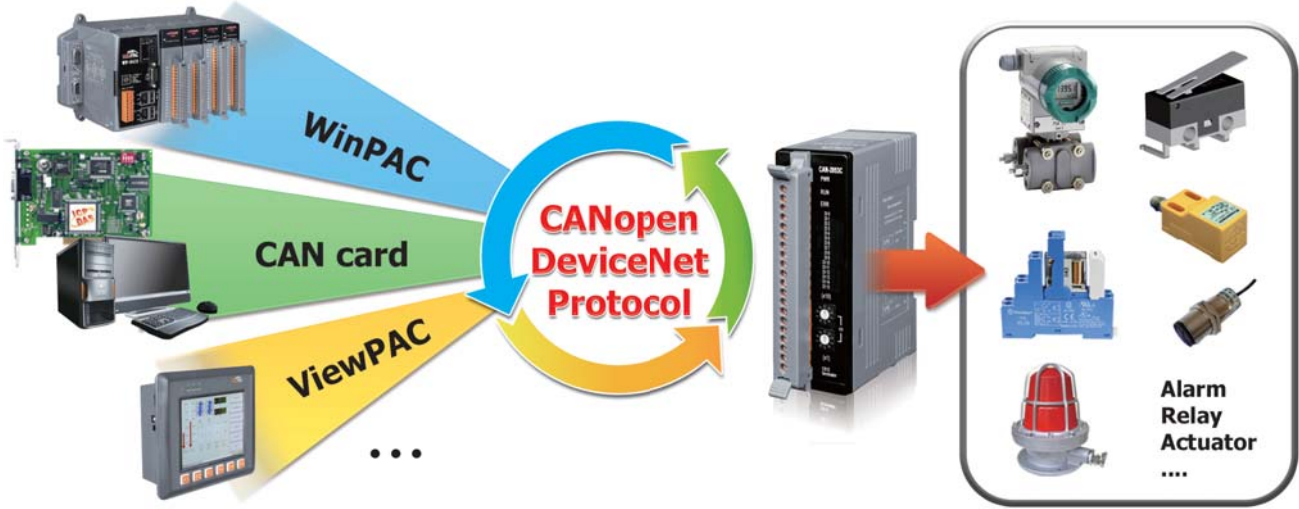

4

CAN Bus

Models	CANopen	CAN-2024C	CAN-2026C	Available Soon	CAN-2028C
	DeviceNet	CAN-2024D	Available Soon	CAN-2026D	Available Soon
		4-Ch AO Module	2-Ch AO, 6-Ch AI, 1-Ch DO and 2-Ch DI Module		8-Ch AO Module
Pictures					
<b>AI</b>					
AO Channels		4	6		8
Wiring		Bipolar/Unipolar	Bipolar/Unipolar		Unipolar
Voltage Output Range		0 ~ +5 V ±5 V 0 ~ +10 V ±10 V	0 ~ +5 V ±5 V 0 ~ +10 V ±10 V		-
Current Output Range		0 ~ 20 mA +4 ~ 20 mA	-		0 ~ 20 mA +4 ~ 20 mA
Resolution		14-bit	12-bit		12-bit
Accuracy		Voltage : ±0.1 % of FSR Current : ±0.2 % of FSR	±0.1 % of FSR		±0.2 % of FSR
Output Capacity		Voltage : 10 V @ 5 mA Current : External +24 V : 1050 Ω	10 V @ 20 mA		External +24 V : 1050 Ω
Power on Value		Yes	Yes		Yes
Safe Value		Yes	Yes		Yes
<b>System</b>					
ESD Protection		4 kV Contact for each channel			
Isolation		3000 VDC for DC-to-DC, 3000 Vrms for bus-to-logic			
Watchdog		Yes			
<b>Power</b>					
Input range		Unregulated +10 ~ +30 Vdc			
Power Consumption		1.5 W	1.8 W		1.4 W
<b>Mechanism</b>					
Installation		DIN-Rail			
Dimensions (W x L x H)		33 mm x 107 mm x 102 mm			
<b>Environment</b>					
Operating Temperature		-25 ~ +75°C			
Storage Temperature		-30 ~ +80°C			
Relative Humidity		10 ~ 90% RH, Non-condensing			

## 4.10.3 Digital I/O Modules

### PWM Introduction >>>





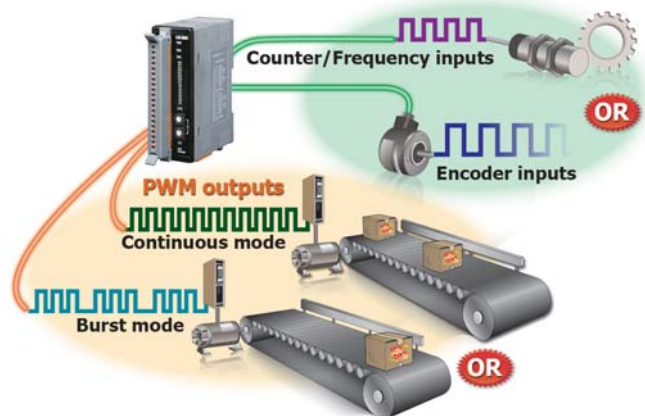

PWM (Pulse width modulation) is a powerful technique for controlling analog circuits. It uses digital outputs to generate a waveform with variant duty cycle and frequency to control analog circuits. CAN-2088C and CAN-2088D have 8 PWM output channels and 8 digital inputs. It can be used to implement powerful and cost effective analog control systems.

### PWM Features >>>

- Automatic generation of PWM outputs by hardware, without software intervention.
- Software and hardware trigger mode for PWM output
- Individual and synchronous PWM output
- Burst mode PWM operation for standby
- DI channel can be configured as simple digital input channel or hardware trigger source of the PWM output

### Applications >>>



Models	CANopen	CAN-2053C	CAN-2054C	CAN-2055C	CAN-2057C	CAN-2060C <i>Available Soon</i>	CAN-2088C
	DeviceNet	CAN-2053D	CAN-2054D	CAN-2055D <i>Available Soon</i>	CAN-2057D	CAN-2060D <i>Available Soon</i>	CAN-2088D
Pictures		16-Ch DI Module 	8-Ch DI, 8-Ch DO Module 	8-Ch DI, 8-Ch DO Module 	16-Ch DO Module 	4-Ch DI, 4-Ch Relay Output Module 	8-Ch DI, 8-Ch PWM Output Module 
<b>DI</b>							
Channels		16	8			4	8
Isolation Voltage		3750 Vrms				3750 Vrms	2500 Vrms
Contact		Wet				Wet/Dry	Wet
Sink/Source (NPN/PNP)		Sink/Source			-	Sink/Source	Sink/Source
ON Voltage Level		+3.5 ~ +30 VDC				+10 ~ +50 VDC	+5.5 ~ 30 VDC
OFF Voltage Level		+1 VDC Max.				+4 VDC Max.	+3 VDC Max.
Counter						10 kHz	500 kHz Max.
<b>DO</b>							
Channels			8	8	16	4	8
Isolation Voltage			3750 Vrms	3750 Vrms	3750 Vrms	3750 Vrms	2500 Vrms
Type			Open Collector	Open Collector	Open Collector	Form A	PWM, TTL
Sink/Source (NPN/PNP)			Sink	Source	Sink	Sink	Sink
Load Voltage			+5 ~ +30 Vdc	+5 ~ +30 Vdc	+5 ~ +30 Vdc	+5 ~ +30 VDC	+3.5 ~ +5 VDC
Max. Load Current			700 mA/channel	700 mA/channel	100 mA/channel	5A/channel	10 mA/Channel
Power on Value			Yes	Yes	Yes	Yes	-
Safe Value			Yes	Yes	Yes	Yes	-
<b>System</b>							
ESD Protection		4 kV Contact for each channel					
Isolation		3000 VDC for DC-to-DC, 2500 Vrms for bus-to-logic					
Watchdog		Yes					
<b>Power</b>							
Input range		Unregulated +10 ~ +30 VDC					
Power Consumption		1.5 W	1.5 W	1.7 W	1.5 W	1.5 W	2 W
<b>Mechanism</b>							
Installation		DIN-Rail					
Dimensions (W x L x H)		33 mm x 107 mm x 102 mm					
<b>Environment</b>							
Operating Temperature		-25 ~ +75°C					
Storage Temperature		-30 ~ +80°C					
Relative Humidity		10 ~ 90% RH, Non-condensing					

### 4.10.4 CANopen I/O Units



#### Features

- 80186, 80 MHz CPU
- One ISO 11898-2 High Speed CAN Port
- Hot Swap Allowed
- Auto Configuration
- Standard CANopen LED Indicator
- Rotary Switch For Baud Rate and Node ID
- CANopen DS 301 Ver 4.02 Specification
- CANopen DS 401 Ver 2.1 Specification
- 1/2/4/8 I/O Slots for I-87K and I-8K Series Modules



#### Specifications >>>

Models	CAN-8123	CAN-8223	CAN-8423	CAN-8823
<b>CAN Interface</b>				
Controller	NXP SJA1000T with 16 MHz clock			
Transceiver	NXP 82C250			
Connector	5-pin screwed terminal block (GND, CAN_L, CAN_SHLD, CAN_H, V+)		5-pin screwed terminal block (N/A, CAN_L, CAN_SHLD, CAN_H, N/A)	9-pin screwed terminal block (N/A, CAN_L, CAN_SHLD, CAN_H, N/A)
Node ID	1~127 (By rotary switch)			
Baud Rate (bps)	10 k, 20 k, 50 k, 125 k, 250 k, 500 k, 800 k, 1 M (By rotary switch)			
Transmission Distance (m)	Depend on baud rate (for example, max. 1000 m at 50 kbps)			
Isolation	1000 VDC for DC-to-DC, 2500 Vrms for photo-couple			
Terminator Resistor	Jumper for 120 Ω terminator resistor			
Specification	ISO 11898-2, CAN 2.0A and CAN 2.0B			
Protocol	CANopen CIA 301 ver4.02, CIA 401 ver2.1			
<b>I/O Expansion Slot</b>				
Hot Swap	Only for I-87K modules			
Auto Configuration	Yes			
Support Module Type	High profile I-87K module, low profile I-87K module and I-8K module			High profile I-8K and I-87K module
Slots Numbers	1	2	4	8
<b>Mechanism</b>				
Dimensions (W x L x H)	64 mm x 119 mm x 91 mm	95 mm x 132 mm x 91 mm	188 mm x 132 mm x 91 mm	312 mm x 132 mm x 91 mm
Installation	DIN-Rail Mounting		DIN-Rail or Wall Mounting	
<b>Environmental</b>				
Operating Temperature	-25 ~ +75°C			
Storage Temperature	-30 ~ +80°C			
Humidity	10 ~ 90% RH (Non-condensing)			
<b>Power</b>				
Input Range	20 W unregulated +10 ~ +30 VDC			
Reverse Polarity Protection	Yes			
Frame Ground	No		Yes	
Consumption	1 W	2 W	2.5 W	3 W
Power Board Driving	20 W			

## 4.10.5 DeviceNet I/O Units



### Features

- 80186, 80 MHz CPU
- One ISO 11898-2 High Speed CAN Port
- Hot Swap Allowed
- Auto Configuration
- Standard DeviceNet LED Indicator
- Rotary Switch For Baudrate and Node ID
- DeviceNet Volume I Ver 2.0, Volume II Ver 2.0
- Predefined Master/Slave Connection Set
- 1/2/4/8 I/O Slots for I-87K and I-8K Series Modules



### Specifications >>>

Models	CAN-8124	CAN-8224	CAN-8424	CAN-8824
<b>CAN Interface</b>				
Controller	NXP SJA1000T with 16 MHz clock			
Transceiver	NXP 82C250			
Connector	5-pin screwed terminal block (GND, CAN_L, CAN_SHLD, CAN_H, V+)		5-pin screwed terminal block (N/A, CAN_L, CAN_SHLD, CAN_H, N/A)	9-pin screwed terminal block (N/A, CAN_L, CAN_SHLD, CAN_H, N/A)
Node ID	1~63 (By rotary switch)			
Baud Rate (bps)	125 k, 250 k, 500 k (By rotary switch)			
Transmission Distance (m)	Depend on baud rate (for example, max. 500 m at 125 kbps )			
Isolation	1000 VDC for DC-to-DC, 2500 Vrms for photo-couple			
Terminator Resistor	Jumper for 120 Ω terminator resistor			
Specification	ISO 11898-2, CAN 2.0A and CAN 2.0B			
Protocol	DeviceNet Volume I ver2.0, Volume II ver2.0 Predefined Master/Slave Connection set			
<b>I/O Expansion Slot</b>				
Hot Swap	Only for I-87K modules			
Auto Configuration	Yes			
Support Module Type	High profile I-87K module, low profile I-87K module and I-8K module			High profile I-8K and I-87K module
Slots Numbers	1	2	4	8
<b>Mechanism</b>				
Dimensions (W x L x H)	64 mm x 119 mm x 91 mm	95 mm x 132 mm x 91 mm	188 mm x 132 mm x 91 mm	312 mm x 132 mm x 91 mm
Installation	DIN-Rail Mounting	DIN-Rail or Wall Mounting		
<b>Environmental</b>				
Operating Temperature	-25 ~ +75°C			
Storage Temperature	-30 ~ +80°C			
Humidity	10 ~ 90% RH (Non-condensing)			
<b>Power</b>				
Input Range	Unregulated +10 ~ +30 VDC			
Reverse Polarity Protection	Yes			
Frame Ground	No		Yes	
Consumption	1.7 W	2 W	2.5 W	3 W
Power Board Driving	20 W			

### 4.10.6 I/O Module Support List of CAN-8000 Units

4

CAN Bus

Type	I-8K Series I/O		I-87K Series I/O		Description	
	High Profile	Low Profile	High Profile	Low Profile		
AI module			I-87005W		8-Ch Thermistor Input Module	
			I-87013W	I-87013	4-Ch RTD Input Module	
			I-87015W		7-Ch RTD Input Module	
			I-87015PW		7-Ch RTD Input Module	
			I-87016W		2-Ch Strain Gauge Input Module	
		I-8017HW	I-8017H	I-87017W	I-87017	8-Ch Voltage/Current Input Module
				I-87017W-A5		8-Ch Voltage/Current Input Module
				I-87017RW		8-Ch Voltage/Current Input Module
				I-87017RCW		8-Ch Current Input Module
				I-87018W	I-87018	8-Ch Thermocouple Input Module
				I-87018RW		8-Ch Thermocouple Input Module
				I-87018ZW		10-Ch Thermocouple Input Module
				I-87019RW		8-Ch Universal AI Module
AO module				I-87022	2-Ch Voltage/Current Output Module	
	I-8024W	I-8024	I-87024W	I-87024	4-Ch Voltage/Current Output Module	
				I-87026	6-Ch AI, 2-Ch AO, 2-Ch DI, 2-Ch DO Module	
DI module	I-8040W	I-8040	I-87040W	I-87040	32-Ch DI (wet, sink/source) Module	
	I-8040PW		I-87040PW		32-Ch DI (wet, sink/source) Module	
	I-8046W		I-87046W		16-Ch DI (dry, source) Module	
	I-8051W	I-8051	I-87051W	I-87051	16-Ch DI (dry, source) Module	
	I-8052W	I-8052	I-87052W	I-87052	8-Ch DI (wet, sink/source) DI Module	
	I-8053W	I-8053	I-87053W	I-87053	16-Ch DI (wet/dry, sink/source) Module	
	I-8053PW		I-87053PW		16-Ch DI (wet/dry, sink/source) Module	
			I-87053W-A5		16-Ch DI (wet/dry, sink/source) Module	
			I-87053W-E5		16-Ch DI (wet/dry, sink/source) Module	
			I-87053W-AC1		16-Ch DI (VAC) Module	
		I-8058W	I-8058	I-87058W	I-87058	8-Ch DI (VAC) Module
			I-87059W		8-Ch DI (VAC) Module	
DO module	I-8037W	I-8037			16-Ch DO (Open Collector, source) Module	
	I-8041W	I-8041	I-87041W	I-87041	32-Ch DO (Open Collector, sink) Module	
	I-8041AW				32-Ch DO (Open Collector, source) Module	
	I-8056W	I-8056			16-Ch DO (Open Collector, sink) Module	
	I-8057W	I-8057	I-87057W	I-87057	16-Ch DO (Open Collector, sink) Module	
	I-8060W	I-8060			6-Ch Power Relay Module	
	I-8064W	I-8064	I-87064W	I-87064	8-Ch Power Relay Module	
		I-8065	I-87065W	I-87065	8-Ch AC SSR Relay Module	
		I-8066	I-87066W	I-87066	8-Ch DC SSR Relay Module	
	I-8068W	I-8068	I-87068W	I-87068	8-Ch Power Relay Module	
I-8069W	I-8069	I-87069W	I-87069	8-Ch PhotoMOS Relay Module		
DI & DO module	I-8042W	I-8042			16-Ch DI (wet, sink/source), 16-Ch DO (Open Collector, sink) Module	
	I-8050W	I-8050			16-Ch universal DIO (wet, sink) Module	
	I-8054W	I-8054	I-87054W	I-87054	8-Ch DI (wet, sink/source), 8-Ch DO (Open Collector, sink) Module	
	I-8055W	I-8055	I-87055W	I-87055	8-Ch DI (dry, source), 16-Ch DO (Open Collector, sink) Module	
	I-8063W	I-8063	I-87063W	I-87063	4-Ch DI (wet, sink/source), 4-Ch Power Relay Module	
Counter module	I-8084W	I-8080			8-Ch Counter/Frequency Input Module	
PWM module	I-8088W				8-Ch DI, 8-Ch PWM Output Module	

**Note: CAN-8823 and CAN-8824 only support high profile I-8K and I-87K modules.**

## 4.11 CANcheck

**CANcheck** – the software is developed by ICP DAS for CAN device detection and diagnosis. It is consisted of seven parts.



### • CAN Message Modeling

Users can model the vehicle CAN protocol or other special CAN protocol, set to the CANcheck software, the software will be able to follow the CAN command set and command transfer cycle. Users could provide the meaningful description for each CAN command. This helps to manage and identify all the complex CAN commands.

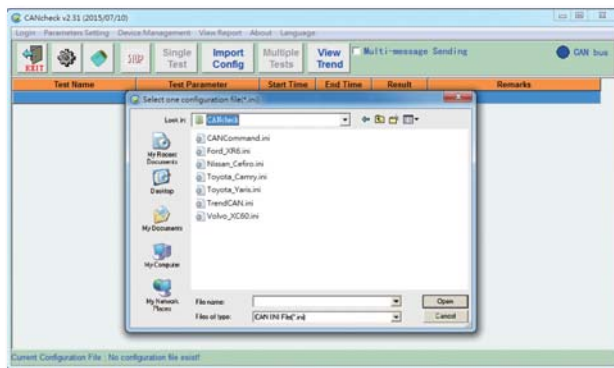

### • CAN Message Verification

Different CAN instruments have different command sets; correspondingly, the return messages also differ. CANcheck can be used to perform verification of expected return messages – an easy way of error-checking operations. This feature does away with manual log-checking, and with it human error and tedium.

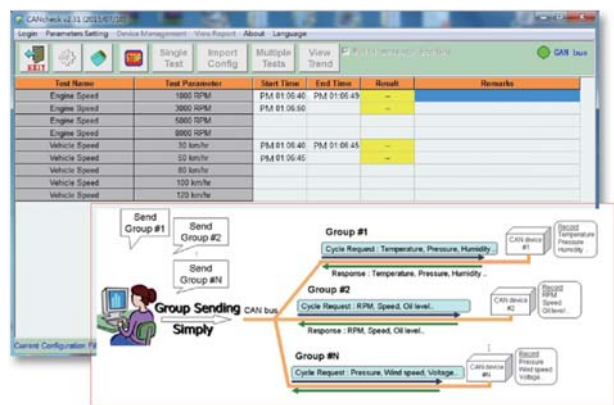

### • CAN Message Management

Different CAN message sets can be stored in different configuration files. The user can easily pipe different configuration files for different test cases. For example, a car factory can store several different cars' data in different configuration files, and then call the corresponding one as needed to test each car.

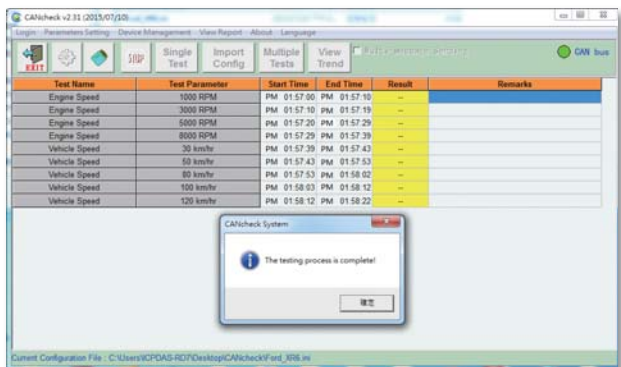

### • CAN Message Group

In most of CAN applications, the CAN master sometimes iteratively polls entire remote devices with the sequential CAN commands. In the multi-message sending mode, CAN messages will be divided into groups according to CAN-ID. In single group, the CAN commands will be sent sequentially at specific time interval. Every group could work individually at the same time. It will simplify the CAN application projects and help to manage CAN devices more efficiently.

## • CAN Data Conversion

The CANcheck software provides the functionality of implementing the conversion of the CAN data. The CAN data of the specific CAN ID could be converted to the value of "long" type, "float" type and etc. When receiving the specific CAN messages, the CAN data will be converted to the specific data type and data value quickly and automatically. The users could focus on those converted value and need not to convert for each raw data manually. This conversion will help the users to deal with the huge raw data more friendly.

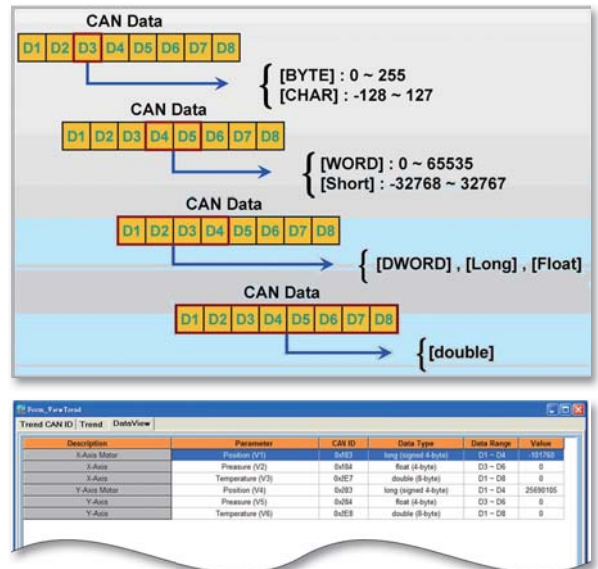
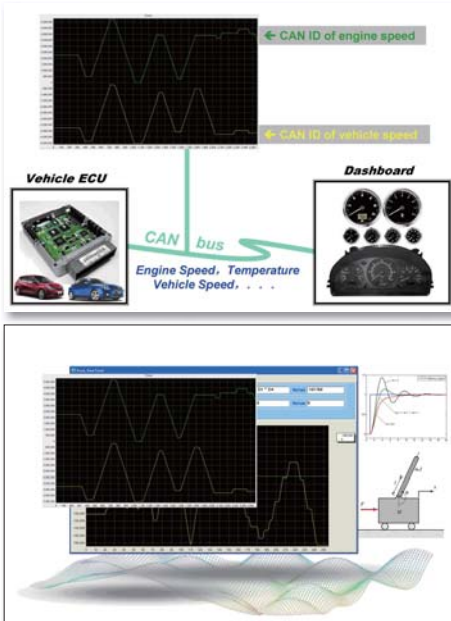

## • Trend Chart Functionality

The CAN messages transmitted on the CAN bus always contains much important information. One part of the information is used to control the system by the host controller, and the other which may not be used by the host controller is interested during the trial run. The CANcheck offers the visualization tool, the trend chart, to monitor the information. It can transfer the raw CAN data into the meaningful and physical information, such as engine speed, vehicle speed and fuel consumption, and show these on the trend chart. Without any modification of the host controller, users can obtain the details change of the system easy and quickly.

## • Real-Time Mathematic Functions

In some applications, the meaningful information must be obtained via a serious of complex mathematical calculation from the raw CAN messages. The CANcheck allows users to arrange up to 4 groups of the mathematical formulas which will transfer the raw data to the useful information instantly while the CAN messages are received. Combined with the trend chart, it is a very useful and helpful toolkit for monitoring or debugging the systems.

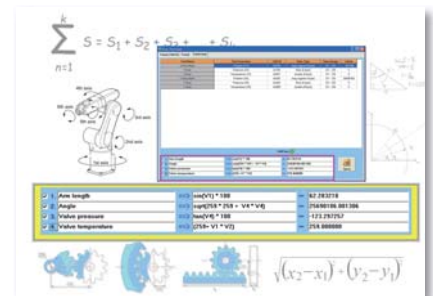

### The detailed features are:

- (1) No need to write any programs. The graphical interface is ready-made and easy to operate.
- (2) Limited to neither the vehicle nor instrument brand; it's interoperable.
- (3) The CAN communication protocol settings file protects against security leaks, ensuring safe operation.
- (4) Can set the returned CAN discrimination, eliminating the hassle of wading through logs and manually interpreting results.
- (5) Can be used to operate and diagnose lights, windows, dashboard or other vehicular electronic systems and components.
- (6) Supports CAN 2.0A and CAN 2.0B specifications.
- (7) The test command planning interface to set the test command, the transfer cycle, detecting the reply command and users' description.
- (8) Can store commands to the specific file.
- (9) Supports both the single- and multi-function tests. In multi-function testing, the software provide multi-message sending option.
- (10) Provides time stamps for the beginning and end of each test.
- (11) Displays real-time CAN status
- (12) Provides the data conversion from the received CAN messages automatically.
- (13) Supports two trends to display the real-time waveform which comes from the CAN messages.
- (14) Provides four free-edited mathematic functions to transfer the raw data instantly and automatically.
- (15) Provides English, Traditional Chinese and Simple Chinese interfaces.

**Supported OS:** Windows XP, 7

**Supported CAN board, converter:** PISO-CAN100U, PISO-CAN200U, PISO-CAN400U, PISO-CAN-800U, PEX-CAN200i, PCM-CAN200, PCM-CAN200P, I-7530, I-7530-FT, I-7530A, I-7530A-MR, I-7540D, I-7540D-MTCP, I-7565, I-7565-H1, I-7565-H2

## Ordering Information >>>

### CANcheck

Software for CAN device detection and diagnosis, USB keypro included.



## 4.12 Case Studies

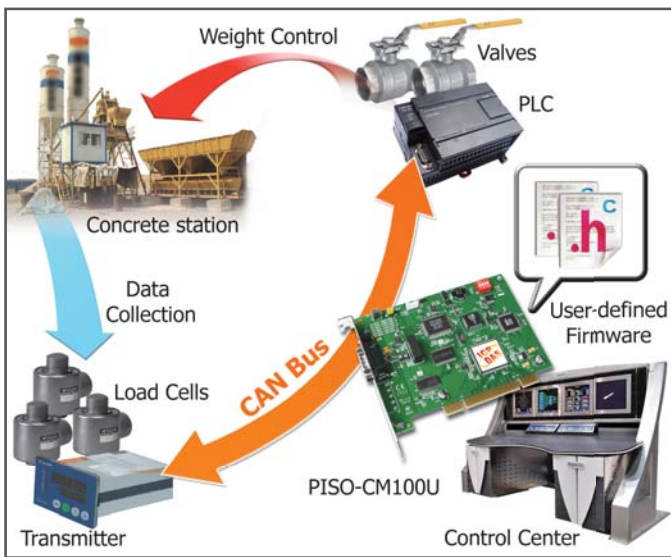

### Concrete Station Monitoring & Control System

- **Location:** China
- **Product:** PISO-CM100U
- **Description:** The result of the quantity control for each recipe material seriously affects the quality of the concrete. In order to adjust each quantity promptly, CAN bus is applied. In this system, the PISO-CM100U is used to monitor the weight of each material from the load cells and send the recipe to the PLC. As the same time, the PC updates all the data on the screen. By utilizing the user-defined firmware in the CPU of the PISO-CM100U, the PC loading can be effectively reduced, and the system becomes more efficient and reliable.



### Cash-in-transit Vehicle

- **Location:** England, United Kingdom
- **Product:** I-7530-FT
- **Description:** A telematics and vehicle control system need to be closely integrated with each other by implementing data exchange interface. LSFT (Low Speed/Fault Tolerance) CAN is a familiar type of interface in the application of automotive electronics systems. The I-7530-FT is specially designed for solving the problem of interface transformation between LSFT CAN and RS-232. In this way, the cash-in-transit of the manufacturer can efficiently control the door of the cash safe and directly monitor the status of the rear access vehicle door on the telematics.

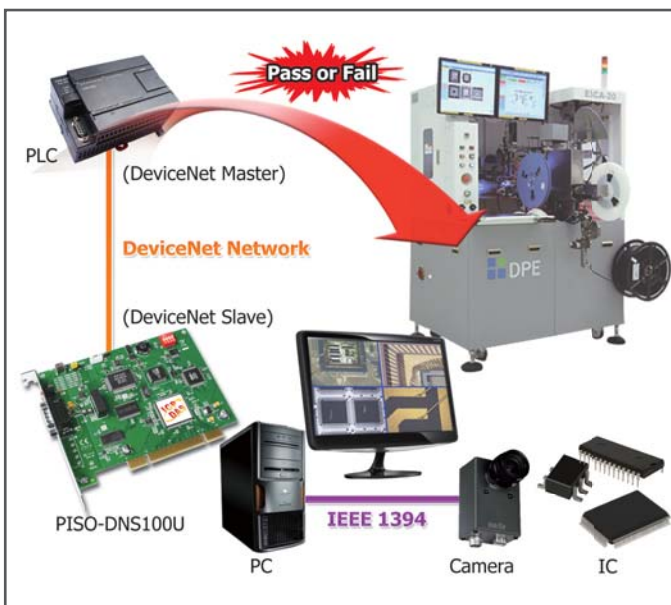

### IC Inspection Machine

- **Location:** Hsinchu, Taiwan
- **Product:** PISO-DNS100U
- **Description:** The IC inspection process is necessary for good quality control. Though PLCs are cheap and stable, IC inspection is a difficult task for a PLC. The user uses a PC plus a camera together with a PISO-DNS100U to perform the IC inspection, and uses a PLC to control the mechanism used to reject defective ICs. After completing the inspection, the PC writes the result to the PISO-DNS100U. Because the PLC is used as a DeviceNet master, it can easily retrieve the information from the PISO-DNS100U via the DeviceNet network.

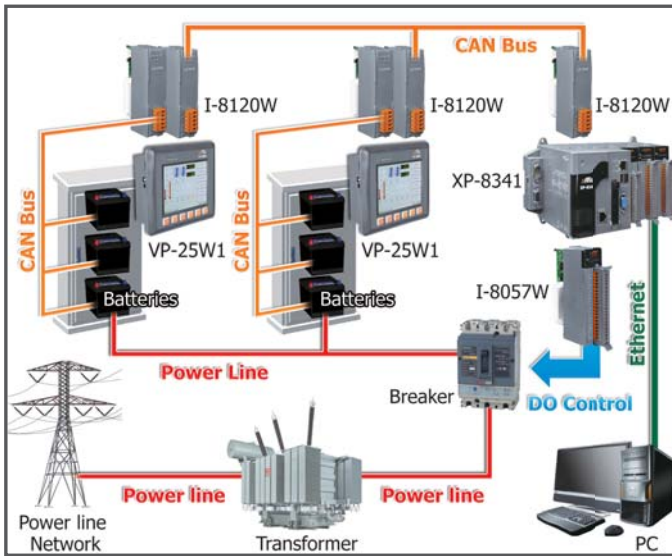

### Energy Storage System

- **Location:** China
- **Product:** I-8120W, I-8057W, VP-25W1, XP-8341
- **Description:** This system improves the usage efficiency of electrical power. During the off-peak time for electricity use, the unused electricity can be stored in batteries. During peak time, these batteries then supply power to the electricity grid. The user has utilized two I-8120W modules plugged in one VP-25W1 in each subsystem. One is for obtaining the battery status, and another is for transmitting the data to the XP-8341. The XP-8341 then transmits the status information to the PC via the Ethernet and controls the charge time using a breaker.

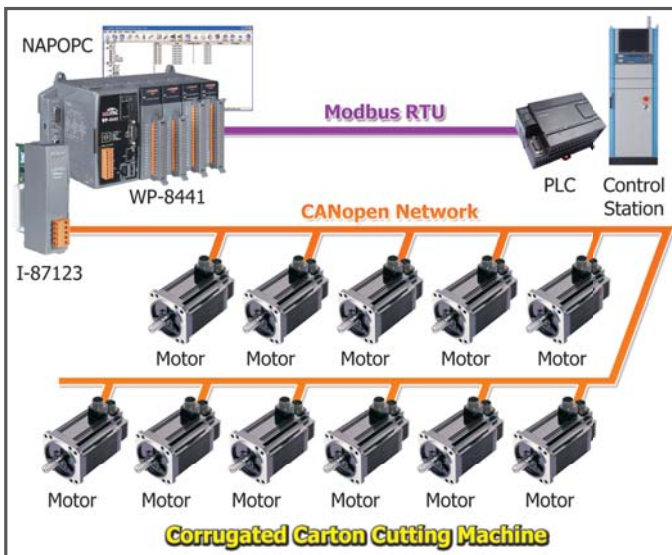

### Corrugated Carton Cutting Machine

- **Location:** Taichung, Taiwan
- **Product:** WP-8441, I-87123
- **Description:** In this case, the orientation and speed of the cutting knives and rollers seriously affects the quality of the output. Because all of the knives and rollers are controlled by 31 motors, the user selected CANopen-based motors in order to achieve that. The WP-8441 and I-87123 together act as a CANopen master to simultaneously control all of the motors, taking advantage of the CANopen features of synchronization and high communication performance. By using this architecture, all of the motors are able to be quickly moved to the target position at the same time by simply sending a single command.

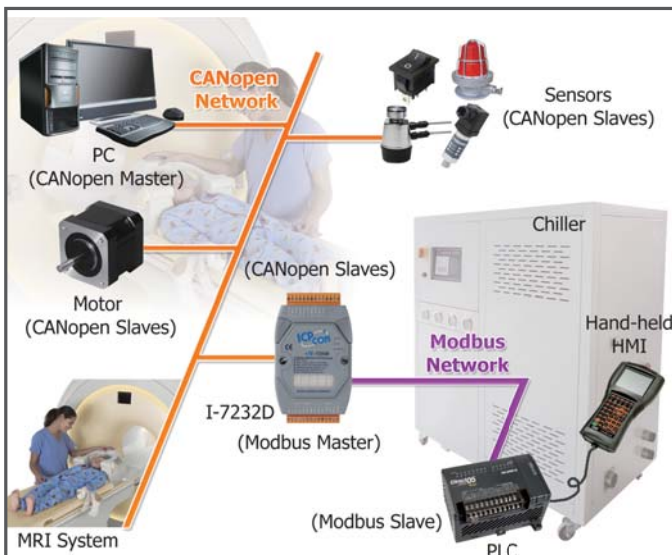

### MRI Cooling System

- **Location:** China
- **Product:** I-7232D
- **Description:** In order to reduce costs, an MRI manufacturer uses a chiller made in China instead of a more expensive German product. However, the user experienced difficulties due to the different communication interfaces. By using the I-7232D, this problem was solved. The I-7232D was able to be used as a Modbus RTU master while communicating with the chiller. In contrast, in the CANopen network, the I-7232D can be used as a CANopen slave. As a result, the I-7232D is able to easily pass information from the chiller to the CANopen master, and conversely transfer CANopen commands to the chiller.

# PROFIBUS Products



## 5.1 Overview P 5-1

- Selection Guide ----- P 5-2

## 5.2 PROFIBUS Converters & Repeaters P 5-3

## 5.3 PROFIBUS Gateways P 5-8

## 5.4 PROFIBUS Remote I/O Modules P 5-11

## 5.5 PROFIBUS Remote I/O Units P 5-13

- I/O Module Support List of PROFIBUS-8000 Units ----- P 5-14

## 5.6 Case Studies P 5-15



## 5.1 Overview



**PROFIBUS** (Process Field Bus) is a standard for fieldbus communication in automation technology and was first promoted (1989) by BMBF (German department of education and research). It is the world's most successful fieldbus, with more than 31 million devices installed by the end of 2009. Over 5.4 million of these were in the process industries.

PROFIBUS (PROCESS FIELD BUS) which is anchored in the international standards IEC 61158 and IEC 61784, is an open, digital communication system with a wide range of applications, particularly in the fields of factory and process automation. It is suitable for both fast, time-critical applications and complex communication tasks. ICP DAS provides a lot PROFIBUS DP products and help the user develop PROFIBUS application system easily. We have been developing and studying PROFIBUS DP for years. ICP DAS will always secure user's industrial safety and stable automation system as our mission.

### Features:

- 124 slaves can be put in Data Exchange.
- Maximum 244 bytes input and 244 bytes output per slave.
- Fast Cyclic data communication between master and slave.
- Slave configuration and parameters are set from the master side by GSD file.
- Allow Multi-master system.
- 32 stations on one segment.
- Baudrate up to 12Mbit/s.

5

PROFIBUS

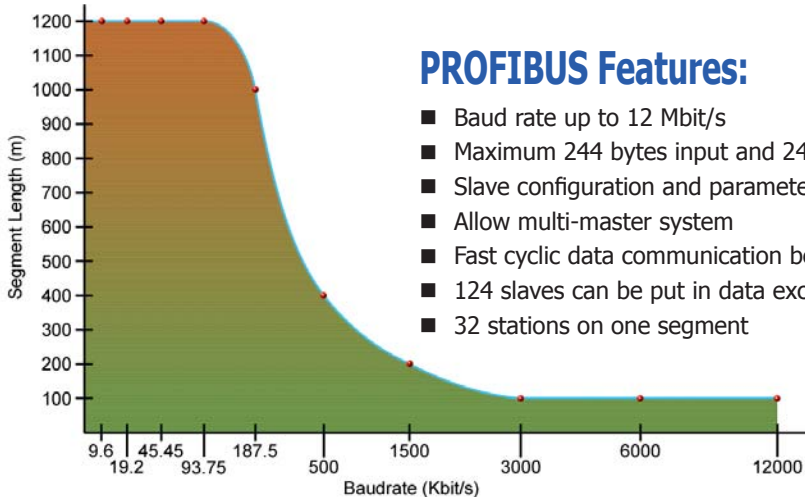
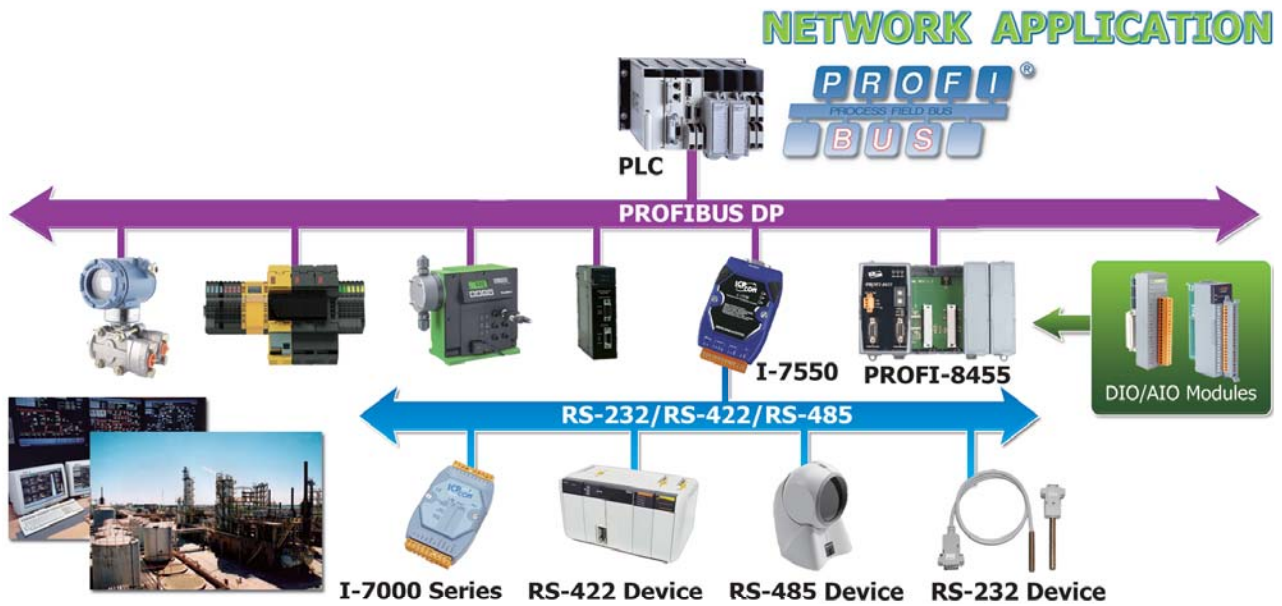

### PROFIBUS Features:

- Baud rate up to 12 Mbit/s
- Maximum 244 bytes input and 244 bytes output per slave
- Slave configuration and parameters are set from the master side by GSD file
- Allow multi-master system
- Fast cyclic data communication between master and slave
- 124 slaves can be put in data exchange
- 32 stations on one segment

## Appearance:

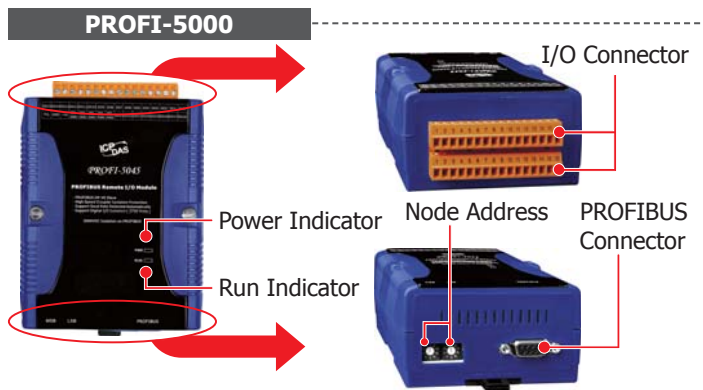

## Hardware:

### 1. Installation



### 2. Dimensions (Units: mm)

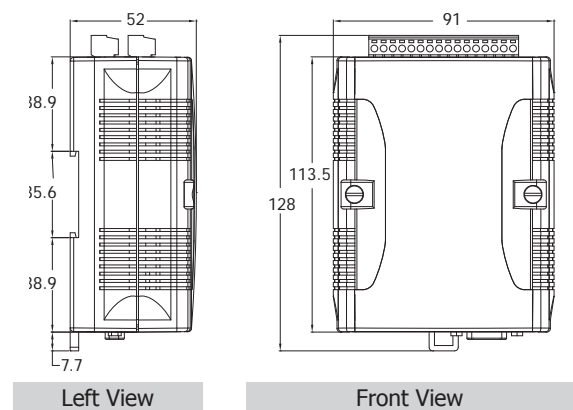

## Selection Guide



	Model Name	Description
<b>Converters</b>	I-7550	PROFIBUS to RS-232/422/485 Converter
	I-7550E	PROFIBUS to Ethernet Converter
	PROFI-2510	Isolated PROFIBUS Repeater
	PROFI-2541	PROFIBUS to Fiber (ST connector) Converter
	PROFI-2541-SC	PROFIBUS to Fiber (SC connector) Converter
	PROFI-2542-SC	PROFIBUS to Single mode Fiber (SC connector) Converter
<b>Gateway</b>	GW-7552	PROFIBUS DP Slave to Modbus RTU Master Gateway
	GW-7553	PROFIBUS DP Slave to Modbus TCP/RTU Master Gateway
	GW-7553-CPM	PROFIBUS DP Slave to CANopen Master Gateway
	GW-7557	PROFIBUS DP Slave to HART Master Gateway
<b>Remote I/O Modules</b>	PROFI-5017	PROFIBUS-DP I/O Module with 8-Ch Voltage Inputs
	PROFI-5017C	PROFIBUS-DP I/O Module with 8-Ch Current Inputs
	PROFI-5018	PROFIBUS-DP I/O Module with 10-Ch Thermocouple Inputs
	PROFI-5024	PROFIBUS-DP I/O Module with 4-Ch Voltage/Current Outputs
	PROFI-5045	PROFIBUS-DP I/O Module with 24-Ch DO
	PROFI-5050	PROFIBUS-DP I/O Module with 16-Ch DI, 8-Ch DO
	PROFI-5051	PROFIBUS-DP I/O Module with 24-Ch DI
	PROFI-5052	PROFIBUS-DP I/O Module with 12-Ch DI
	PROFI-5053	PROFIBUS-DP I/O Module with 24-Ch DI
	PROFI-5055	PROFIBUS-DP I/O Module with 8-Ch DI, 8-Ch DO
	PROFI-5060	PROFIBUS-DP I/O Module with 8-Ch DI, 6-Ch Relay
<b>Remote I/O units</b>	PROFI-8155	PROFIBUS-DP I/O Unit with 1 I/O slot
	PROFI-8255	PROFIBUS-DP I/O Unit with 2 I/O slots
	PROFI-8455	PROFIBUS-DP I/O Unit with 4 I/O slots
	PROFI-8855	PROFIBUS-DP I/O Unit with 8 I/O slots
<b>Accessories</b>	CNT-PROFI	PROFIBUS 9-pin D-Sub Male Connector



## 5.2 PROFIBUS Converters & Repeaters

The PROFIBUS repeaters/converters are used to solve the issues of the PROFIBUS segment, transmission distance and disturbance when setting up a PROFIBUS network. If it is necessary to integrate the different communication interface, the PROFIBUS converter is helpful. The application architectures as following figures provide the examples to show when and how to apply these products.

5

PROFIBUS

Models	I-7550	I-7550-E	PROFI-2510
	PROFIBUS to RS-232/422/485 Converter	PROFIBUS to Ethernet Converter	Isolated PROFIBUS Repeater
Pictures			
PROFIBUS Channel	1		2
PROFIBUS Baud Rate (bps)	9.6 k ~ 12 M		
PROFIBUS Protocol	DP-V0 Slave		DP-V0/DP-V1/DP-V2
PROFIBUS Address	0 ~ 126 set by DIP switch		-
PROFIBUS Transmission Distance (m)	Depend on baud rate		
COM 1	RS-232/RS-485/RS-422	RS-232	-
COM 1 Baud Rate (bps)	1.2 K ~ 115.2 K	115.2K	-
Fiber Channel			
Fiber Connector	-		
Fiber Transmission Distance (m)			
Ethernet Speed	-	10/100M	-
Ethernet Protocol	-	TCP/UDP Server/Client	-

Models	PROFI-2541	PROFI-2541-SC	PROFI-2542-SC
	PROFIBUS to Fiber Converter	PROFIBUS to Fiber Converter	PROFIBUS to Fiber Converter
Pictures			
PROFIBUS Channel	1		
PROFIBUS Baud Rate (bps)	9.6 k ~ 3 M		9.6K~12M
PROFIBUS Protocol	DP-V0/DP-V1/DP-V2		
PROFIBUS Address	-		
PROFIBUS Transmission Distance (m)	Depend on baud rate		
COM 1	-		
COM 1 Baud Rate (bps)	-		
Fiber Channel	1		
Fiber Connector	ST (Multi-mode)	SC (Multi-mode)	SC (Single-mode)
Fiber Transmission Distance (m)	1.4 km Max. (in 62.5/125 μm fiber cable)		10 KM Max.
Ethernet Speed	-		
Ethernet Protocol	-		

## Accessories:

Optional PROFIBUS connector: CNT-PROFI

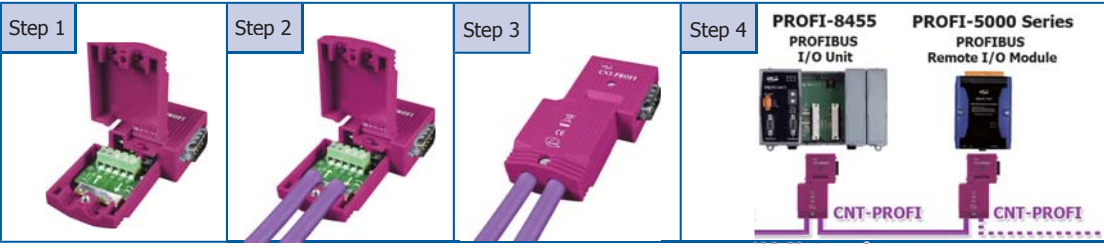

The installation process is shown in four steps: Step 1: Opening the connector housing; Step 2: Inserting the terminal block; Step 3: Closing the housing; Step 4: Connecting the CNT-PROFI connector to a PROFIBUS I/O Unit (PROFI-8455) and a Remote I/O Module (PROFI-5000 Series).

Installation

## PROFIBUS to RS-232/422/485 Converter

### I-7550



The I-7550 converter is specially designed for the slave device of PROFIBUS DP protocol. It offers RS-232, RS-422, and RS-485 communication ports. With the hybrid design of the COM 1, you can choose one type of this COM port for implement. Through the I-7550, applying RS-232/RS-422/RS-485 devices into PROFIBUS network is getting easily.

- Protocol PROFIBUS DP-V0 slave
- Detect transmission rate (9.6 to 12000 kbps) on PROFIBUS automatically
- 128 bytes Max. input data length
- 128 bytes Max. output data length
- PROFIBUS address 0 ~ 126 set by DIP switch
- Support several kinds of baud for COM1 from 1.2 ~ 115.2 kbps
- Network isolation Protection: 2500 Vrms high speed iCoupler
- 3000 VDC isolation protection on PROFIBUS side



NEW

## PROFIBUS to Ethernet Converter

### I-7550-E



The I-7550-E converter is a PROFIBUS DP slave device that provides the communication between PROFIBUS master device and Ethernet device. In the Ethernet network, the I-7550-E offers TCP and UDP Protocol. It can be set as Server to access TCP/UDP clients, or be set as Client to connect with TCP/UDP Server. I-7550-E also provides web configuration that helps user setup the communication of Ethernet. Through the I-7550-E, applying Ethernet device into PROFIBUS network is getting easily.

- Protocol PROFIBUS DP-V0 slave
- 240 bytes Max. input data length
- 240 bytes Max. output data length
- Support Web Configuration
- Support TCP/UDP Client/Server
- Support Ethernet/RS-232 update firmware
- PROFIBUS address 0 ~ 126 set by DIP switch
- Support one 10/100 Base-TX Ethernet port
- Network isolation protection: 2500 Vrms high speed iCoupler
- Detect transmission rate (9.6 to 12000 kbps) on PROFIBUS automatically



5

PROFIBUS

NEW

## Isolated PROFIBUS Repeater

### PROFI-2510



The PROFI-2510 is a PROFIBUS repeater adaptor. According to the PROFIBUS DP specification, there are maximum 32 devices in one PROFIBUS network segment. The maximum bus length of one segment is decided by the network baud rate. Any two segments need to be connected with each other by a repeater adaptor. If the users' application structure includes more than 32 PROFIBUS devices in the network or has more than 1 network segment in order to extend the total bus length, the PROFI-2510 is helpful to solve the issue of the bus length or device number expansion. As other Fieldbus networks, the PROFIBUS network also follows daisy-chain topology. Through the PROFI-2510, it is allowed that users are able to set up their PROFIBUS networks by using various topologies, such as stub lines, tree topology, and star topology.

- Provide status LEDs
- 2500 VDC isolation protection on PROFIBUS side
- 4 kV Contact ESD protection for any terminal
- Detect transmission rate (9.6 k ~ 12000 kbps) automatically
- Wide range of power input (10 ~ 30 VDC) and operating temperature (-25 ~ +75°C)
- No additional space needed in the cabinet
- Can be used as a bus extension or spur line
- Increases the number of nodes

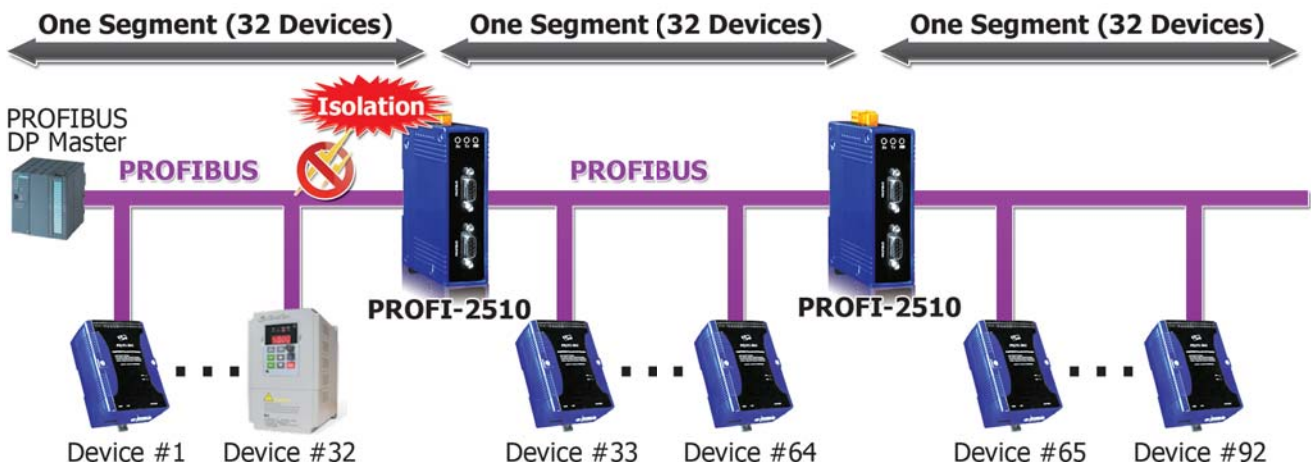



## PROFIBUS to Fiber Converter

### PROFI-2541 PROFI-2541-SC



PROFI-2541 PROFI-2541-SC

Similar to the PROFI-2510, the PROFI-2541 can reshape the PROFIBUS waveform disturbed by the noise, and expand the connectable number of the PROFIBUS devices in the network. The difference is that the PROFI-2541 offers the fiber optic interface which can transfer the PROFIBUS messages to fiber signals, and users can extend the PROFIBUS bus length as the maximum transmission distance of the applied fiber optic. Users can use one pair of the PROFI-2541s instead of more repeaters while extending the bus length. The PROFI-2541 has passed the test of the 4 kV contact ESD, and provides the isolation protections on each PROFIBUS communication port. This feature means that the PROFIBUS-2541 can offer effective protection, and prevent the devices of one segment from the noise of the other segments.

- Fiber Port: ST (Multi-mode)
- Wave Length: 850 nm
- Provide status LEDs
- 2500 VDC isolation protection on PROFIBUS side
- 4 kV Contact ESD protection for any terminal
- Detect transmission rate (9.6 k ~ 3000 kbps) automatically
- Wide range of power input (10 ~ 30 VDC) and operating temperature (-25 ~ +75°C)

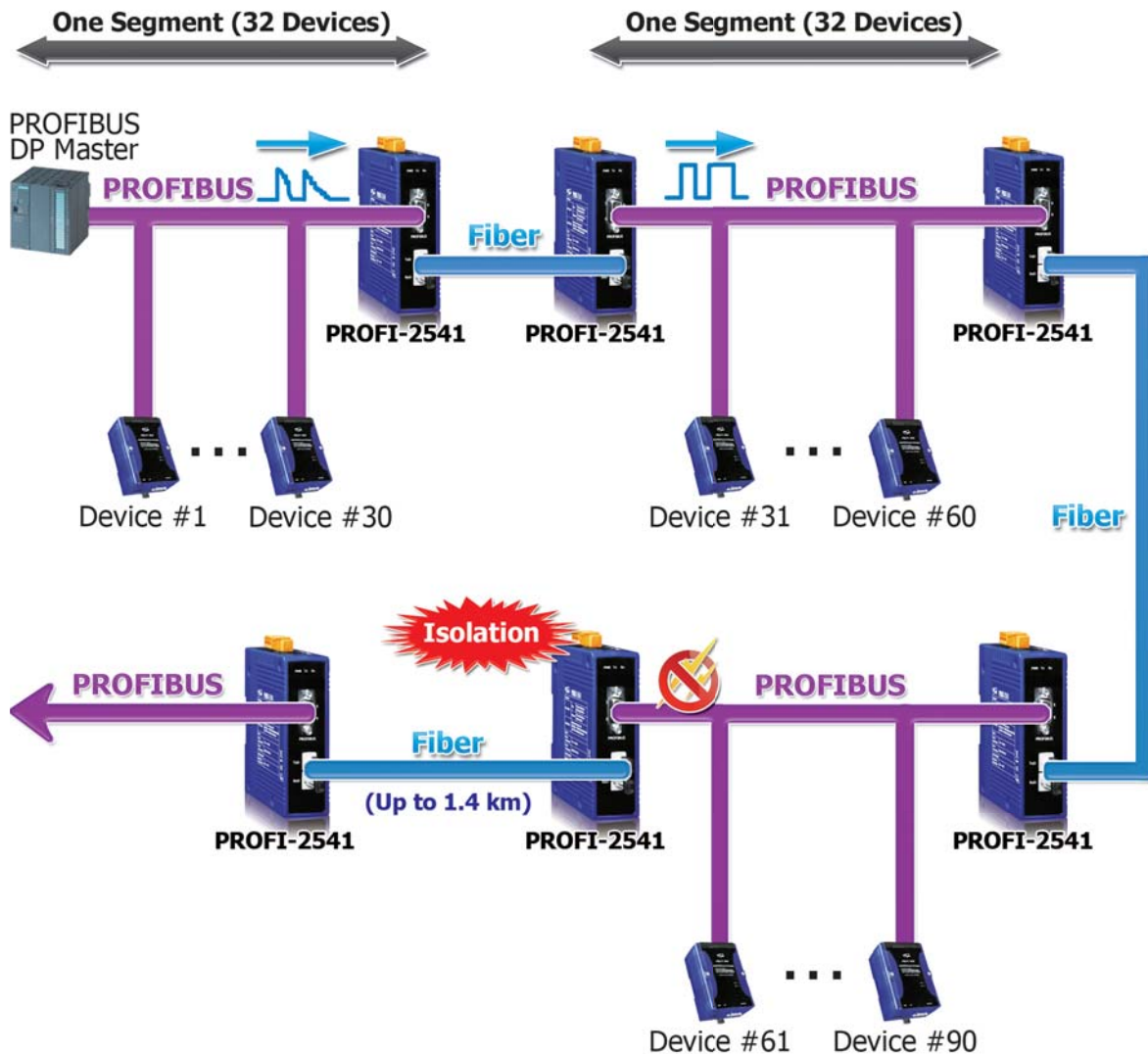

NEW

### Isolated PROFIBUS Repeater

#### PROFI-2542-SC



The PROFIBUS-2542-SC is a PROFIBUS to single mode fiber optic converter which secures PROFIBUS data transmission via single mode fiber optic for providing immunity from EMI/RFI interference. It is used in PROFIBUS applications for transferring PROFIBUS signal from wire to single mode fiber optic and vice versa, and is the perfect solution for applications where transmission must be protected from electrical exposure, surges, lightning or chemical corrosion.

- Protocol : PROFIBUS DP
- Detect transmission rate (9.6 ~ 12000 kbps) automatically
- Max transmission speed up to 12 Mbps for PROFIBUS
- Transparency on both side
- Fiber Port: SC (Single-mode)
- Wave Length: 1310 nm
- Network Isolation Protection: High Speed iCoupler
- 3000 VDC isolation protection on PROFIBUS side
- 4 kV ESD Protection
- Removable terminal block

5

PROFIBUS



Train Station



**FIBER**  
up to 10 km







Railroad Crossing

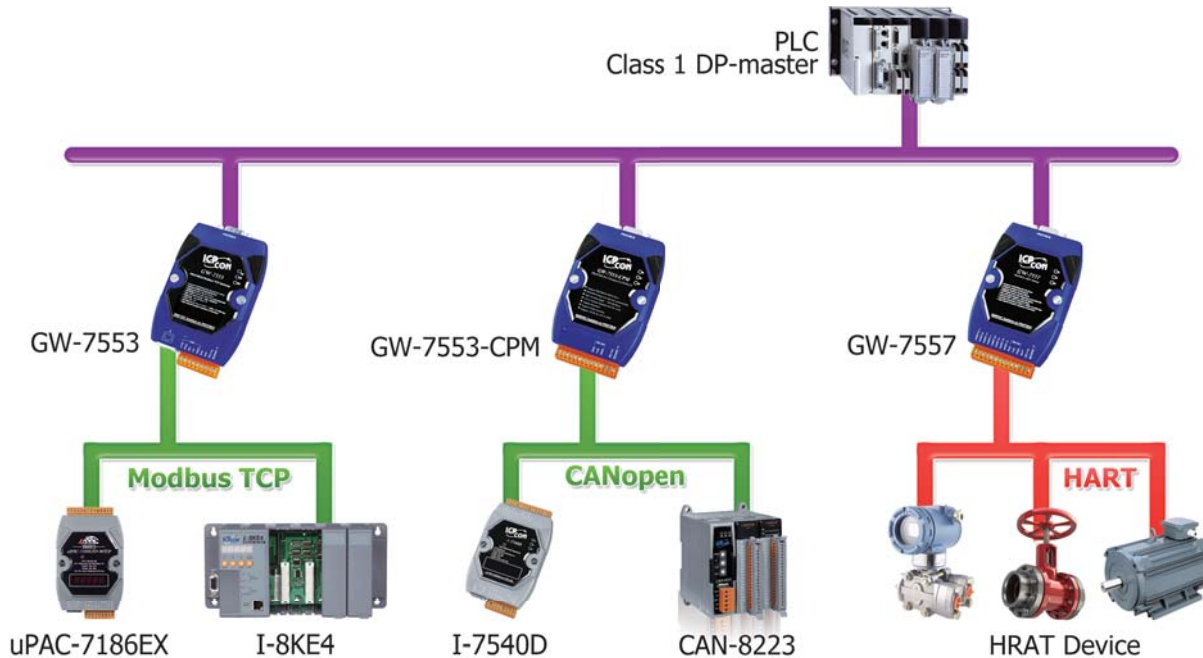

## 5.3 PROFIBUS Gateways

The PROFIBUS gateway is used to solve data-exchanging between different communication network and PROFIBUS network. If it is necessary to integrate different communication protocols to PROFIBUS, the PROFIBUS gateway is helpful. The application architectures as following figures provide the examples to show when and how to apply these products.



Models		GW-7552	GW-7553	GW-7553-CPM	GW-7557
Pictures		PROFIBUS DP Slave to Modbus RTU Gateway	PROFIBUS DP Slave to Modbus TCP/RTU Gateway	PROFIBUS DP Slave to CANopen Gateway	PROFIBUS DP Slave to HART Master Gateway
				<i>Available Soon</i> 	
PROFIBUS	Channel	1			
	Baud Rate (bps)	9.6 k ~ 12 M			
	Protocol	DP-V0 Slave	DP-V0 Slave/DP-V1 Slave	DP-V0 Slave	
	Input/Output Data Length	132/131 Bytes	240/240 Bytes		
COM port	Type	1 x RS-232/422/485	1 x RS-232		
	Baud Rate (bps)	2.4 k ~ 115.2 k			
	Protocol	Modbus RTU/ASCII, Master/Slave		Only for configuration	
Ethernet Port	Speed	–	10/100 M	–	–
	Protocol	–	Modbus TCP Server/Client	–	–
HART	Channel	–	–	–	4
	Protocol	–	–	–	HART Master
CANopen	Channel	–	–	1	–
	Baud Rate (bps)	–	–	10 K, 20 K, 50 K, 125 K, 250 K, 500 K, 800 K, 1 M	–
	Protocol	–	–	CANopen master	–

## PROFIBUS DP Slave to Modbus RTU Master Gateway

### GW-7552



The GW-7552 gateway is a PROFIBUS DP slave. It allows the PROFIBUS master to access the Modbus RTU devices. In the Modbus network, the GW-7552 can be a master to access the Modbus slaves, or be a slave to provide the data from the PROFIBUS master. The flexible design lets the GW-7552 widely applying in the many applications.

- Protocol PROFIBUS DP-V0 Slave
- 132 bytes Max. input data length
- 131 bytes Max. output data length
- Support Modbus master mode and slave mode
- PROFIBUS address 0 ~ 126 set by DIP switch
- 3000 VDC isolation protection on PROFIBUS side
- Support several kinds of baud for COM1 from 2.4 ~ 115.2 kbps
- Network Isolation Protection: 2500 Vrms High Speed iCoupler
- Detect transmission rate (9.6 to kbps) 12000 on PROFIBUS automatically

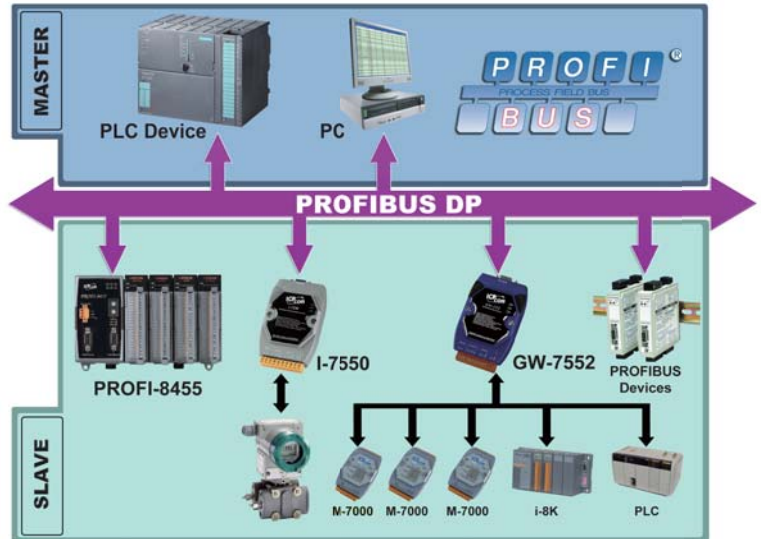

## PROFIBUS DP Slave to Modbus TCP/RTU Gateway

### GW-7553



The GW-7553 is used for data-exchange between the Modbus TCP/RTU network and the PROFIBUS network. It provides not only the Modbus TCP client and server functions, but the Modbus RTU master and slave functions. Therefore, the GW-7553 can satisfy most of the applications of the data transfer between Modbus and PROFIBUS.

- |  |  |
|--|--|
| ■ Protocol PROFIBUS DP-V0 & DP-V1 slave    | ■ Support Modbus TCP/RTU/ASCII protocol                                  |
| ■ Support one 10/100 Base-TX Ethernet port | ■ PROFIBUS address 0 ~ 126 set by DIP switch                             |
| ■ Support one RS-232 port                  | ■ 3000 VDC isolation protection on PROFIBUS side                         |
| ■ 240 bytes Max. input data length         | ■ Network isolation protection: 2500 Vrms high speed iCoupler            |
| ■ 240 bytes Max. output data length        | ■ Detect transmission rate (9.6 to 12000 kbps) on PROFIBUS automatically |

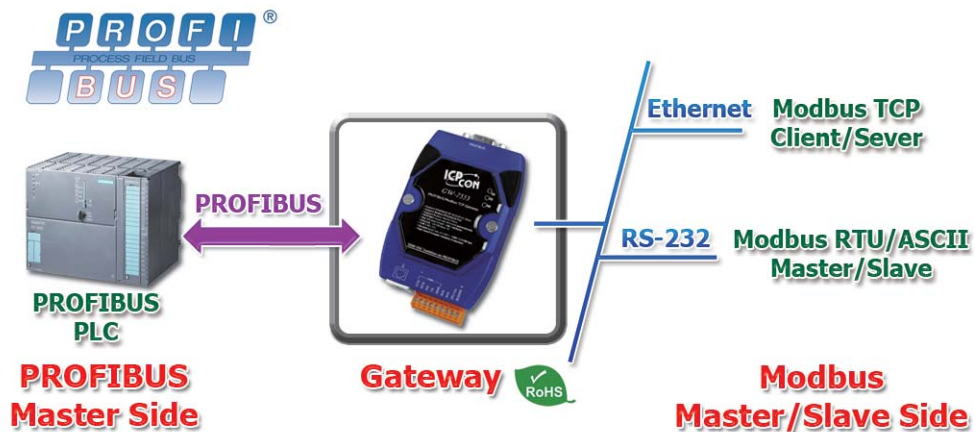

Available soon

## PROFIBUS DP Slave to CANopen Master Gateway

### GW-7553-CPM



The GW-7553-CPM is designed for the slave device of PROFIBUS DP protocol. It allows PROFIBUS master to access CANopen slave devices. These CANopen slave device may be a sensor, actuators, ICPDAS CAN-2000 series modules and so forth. In addition, we also provide the utility software for users to configure the GW-7553-CPM. By using this module, users can put their CANopen slave devices into PROFIBUS network very easily.

- Protocol: PROFIBUS DP-V0 slave
- 240 bytes Max. input data length
- 240 bytes Max. output data length
- Support Heartbeat function
- Support Node Guarding
- PROFIBUS address 0 ~ 126 set by DIP switch
- Follow the CiA CANopen Standard DS-301 v4.02
- Support 110 CANopen SDO/PDO commands
- 3000 VDC isolation protection on PROFIBUS side
- Network isolation protection: 2500 Vrms high speed iCoupler
- Detect Transmission rate (9.6 to 12000 kbps) on PROFIBUS automatically



## PROFIBUS DP Slave to HART Master Gateway

### GW-7557



The GW-7557 is designed for the slave device of PROFIBUS DP protocol. It allows the PROFIBUS master to access the HART slave devices. These HART devices may be a transmitter, an actuator, a current output device and so forth. Owing to the GW-7557, you can communicate the HART slave devices into PROFIBUS network very easily.

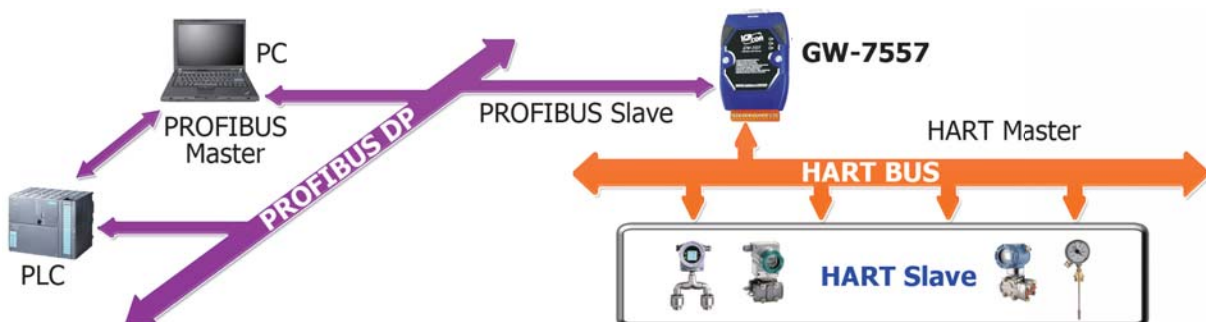

- Protocol: PROFIBUS DP-V0 slave
- 240 bytes Max. input data length
- 240 bytes Max. output data length
- Support HART Short/Long frame
- PROFIBUS address 0 ~ 126 set by DIP switch
- Support HART mode: point-to-point/multi-drop
- Support 4 HART channels, each for Max. 15 HART modules
- 3000 VDC isolation protection on PROFIBUS side
- Network isolation protection: 2500 Vrms high speed iCoupler
- Detect transmission rate (9.6 to 12000 kbps) on PROFIBUS automatically



## 5.4 PROFIBUS Remote I/O Modules

5

PROFIBUS

PROFIBUS Analog Input Modules			
Model Name	PROFI-5017	PROFI-5017C	PROFI-5018
	8-Ch Voltage Input Module	8-Ch Current Input Module	10-Ch Thermocouple Input Module
Pictures			
Channels	8	8	10
Wiring	Differential	Differential	Differential
Individual Channel	Yes	Yes	Yes
Sensor Type	-	-	Thermocouple (J, K, T, E, R, S, B, N, C)
Voltage Input Range	±10 V ±5 V ±2.5 V ±1.25 V	-	±2.5 V ±1 V ±500 mV ±100 mV ±50 mV ±15 mV
Current Input Range	-	±20 mA (Required External 125Ω Resistor)	±20 mA (Required External 125Ω Resistor)
Resolution	14-bit	14-bit	16-bit
Sampling Rate	10 Hz	10 Hz	10 Hz
Accuracy	±0.1 % of FSR	±0.2 % of FSR	±0.1 % of FSR
Zero Drift	±0.5 μV/ °C	±10 μV/ °C	±0.5 μV/ °C
Span Drift	±20 μV/ °C	±25 μV/ °C	±25 ppm
Overvoltage Protection	120 VDC / 110 VAC	240 Vrms	N/A
Input Impedance	20 MΩ	2 MΩ	20 kΩ
Common Mode Rejection	150 dB	86 dB	150 dB
Normal Mode Rejection	100 dB	100 dB	100 dB

PROFIBUS Analog Output Modules		
Model Name	PROFI-5024	
	4-Ch Voltage/Current Output Module	
Pictures		
Channels	4	
Wiring	Differential	
Voltage Output Range	±10 V	
Current Output Range	0 ~ 20 mA, 4 ~ 20 mA	
Resolution	12-bit	
Accuracy	For Voltage Output	±0.1% of FSR
	For Current Output	±0.2% of FSR
Isolation	3000 Vdc	

## PROFIBUS Digital I/O Modules

Model Name	PROFI-5045	PROFI-5050	PROFI-5051	PROFI-5052	PROFI-5053	PROFI-5055	PROFI-5060
Pictures							
<b>DI</b>							
Channels		16	24	12	24	8	8
Isolation Voltage		-	3750 Vrms	5000 Vrms	-	3750 Vrms	3750 Vrms
Contact		Dry	Wet	Wet	Dry	Wet	Wet
Sink/Source (NPN/PNP)	-	Sink/Source	Sink/Source	Sink/Source	-	Sink/Source	Sink/Source
ON Voltage Level		+4 ~ +30 VDC	+10 ~ +50 VDC	+4 ~ +30 VDC	Open	+10 ~ +50 VDC	+4 ~ +30 VDC
OFF Voltage Level		+1 VDC Max.	+4 VDC Max.	+1 VDC Max.	Close to IN.GND	+4 VDC Max.	+1 VDC Max.
Input Impedance		-	10 K $\Omega$	3 K $\Omega$	-	10 K $\Omega$	3 K $\Omega$
<b>DO</b>							
Channels	24	8				8	4
Isolation Voltage	3750 Vrms	-				3750 Vrms	-
Type	Open Collector	Open Collector				Open Collector	Relay (Form C)
Sink/Source (NPN/PNP)	Sink	Sink	-	-	-	Sink	-
Load Voltage	+10 ~ +40 VDC	+10 ~ +30 VDC				+10 ~ +40 VDC	0 ~ 125 VDC 0 ~ 30 VDC
Max. Load Current	650mA/channel	30 mA/channel				650 mA/channel	0.6 A @ 125 VDC 2 A @ 30 VDC
<b>Communication</b>							
Connector	9-pin female D-Sub						
Baud Rate (bps)	9.6 k, 19.2 k, 45.45 k, 93.75 k, 187.5 k, 500 k, 1.5 M, 3 M, 6 M, 12 M						
Controller	Profichip VPCLS2						
Transceiver	ADI ADM2486						
Protocol	DP-V0						
Node Address	0 ~ 99 selected by rotary switch						
<b>System</b>							
ESD Protection	4 kV Contact for each channel						
Isolation	3000 VDC for DC-to-DC, 2500 Vrms for bus-to-logic						
Watchdog	Yes						
<b>Power</b>							
Input range	Unregulated +10 ~ +40 Vdc						
Power Consumption	1 W	1 W	1 W	1 W	1 W	1 W	1 W
<b>Mechanism</b>							
Installation	DIN-Rail						
Dimensions (W x L x H)	91 mm x 128 mm x 52 mm						
<b>Environment</b>							
Operating Temperature	-25 ~ +75°C						
Storage Temperature	-30 ~ +80°C						
Relative Humidity	10 ~ 90% RH, Non-condensing						

## Application:



Optional PROFIBUS connector: CNT-PROFI



Installation

## 5.5 PROFIBUS Remote I/O Units



### Features

- Protocol & hierarchy: DP-V0 & DP-V1 Slave
- Detect transmission Rate Automatically (Max.12 Mbps)
- Support Device-Related & Channel-Related Diagnosis
- Address 0 ~ 126 Set by Rotary Switches or SSA-Telegram
- Support Hot-Swap for I-87K High-Profile I/O Modules
- 3000 VDC Isolation Protection on PROFIBUS side
- 1/2/4/8 I/O Slots for I-87K and I-8K Series I/O Modules
- 4 KV ESD Protection (contacting for any terminal)



### Introduction >>>

The PROFI-8x55 Remote I/O Unit is designed for the slave device of PROFIBUS DP protocol. It supports up to 1/2/4/8 slots for ICPDAS I-8k, I-87k series I/O modules. In addition, we also provide hot-swap function for I-87k High Profiles series I/O modules. To setup network, users can choose and configure I/O modules by using the GSD file without any other setting tools.

### System Specifications >>>

Models	PROFI-8155	PROFI-8255	PROFI-8455	PROFI-8855
UART Interface				
COM 1	On-Board at JP1 (RS-232 for Update Firmware purpose). Note 1.		at Front Panel	
I/O Expansion Slot				
Hot Swap	Yes			
Auto Configuration	Yes			
Support Module Type	High/low profile I-8K & I-87K I/O module			High profile I-8K & I-87K I/O module
Slots Numbers	1	2	4	8
LED				
Round LED	PWR LED, RUN LED, ERR LED			
PROFIBUS Features				
Protocol & Hierarchy	DP-V0 & DP-V1 (Read/Write)		DP-V0 Slave	DP-V0 Slave
Address Setting	0~126 set by Rotary Switches or SSA-telegram set by DP-Master (Class 2)		0~126 set by Rotary switches	
Supports Transmission Rate (Kbps)	9.6, 19.2, 45.45, 93.75, 187.5, 500, 1500, 3000, 6000, 12000			
Transmission Rate Setting	detected automatically			
Indicators	PWR, ERR, and RUN LEDs			
I/O modules Configuration	Configured by GSD file			
Network Isolation Protection	High Speed iCoupler			
DC Isolation Protection	3000 VDC on PROFIBUS side			
Max. Input/Output Data Length	128 Bytes			240 Bytes
Number of Channel of Diag.	32		39	
Device-Related Diag. Type	Offline Detection			
Programmable Diag. period	Supported			
Mechanism				
Dimensions (W x L x H)	64 x 119x 91 (mm)	95 x 132 x 91 (mm)	188 x 132x 91 (mm)	312 x 132 x 91 (mm)
Environmental				
Operating Temperature	-25 ~ +75°C			
Storage Temperature	-30 ~ +80°C			
Humidity	10 ~ 90% RH (Non-condensing)			
Power				
Input Range	Unregulated +10 ~ +30 VDC			
Reverse Polarity Protection	YES			
Frame Ground	YES			
Consumption	3 W	3 W	5 W	5.5 W
Power Board Driving	8 W	8 W	25 W	25 W

**Note 1: CA-0904 : transform from 4-pin connector to 9-pin Female D-Sub connector.**





## I/O Module Support List of PROFIBUS-8000 Units

Type	I-8K Series I/O		I-87K Series I/O		Description
	High Profile	Low Profile	High Profile	Low Profile	
AI module			I-87013W	I-87013	4-Ch RTD Input Module
			I-87015W		7-Ch RTD Input Module
			I-87015PW		7-Ch RTD Input Module
	I-8017HW	I-8017H	I-87017W	I-87017	8-Ch Voltage/Current Input Module
			I-87017W-A5		8-Ch Voltage/Current Input Module
			I-87017RW		8-Ch Voltage/Current Input Module
			I-87017RCW		8-Ch Current Input Module
			I-87018W	I-87018	8-Ch Thermocouple Input Module
			I-87018RW		8-Ch Thermocouple Input Module
			I-87018ZW		10-Ch Thermocouple Input Module
		I-87019RW		8-Ch Universal AI Module	
AO module				I-87022	2-Ch Voltage/Current Output Module
	I-8024W	I-8024	I-87024W	I-87024	4-Ch Voltage/Current Output Module
				I-87026	6-Ch AI, 2-Ch AO, 2-Ch DI, 2-Ch DO Module
DI module	I-8040W	I-8040	I-87040W	I-87040	32-Ch DI (wet, sink/source) Module
	I-8040PW		I-87040PW		32-Ch DI (wet, sink/source) Module
			I-87046W		16-Ch DI (dry, source) Module
	I-8051W	I-8051	I-87051W	I-87051	16-Ch DI (dry, source) Module
	I-8052W	I-8052	I-87052W	I-87052	8-Ch DI (wet, sink/source) DI Module
	I-8053W	I-8053	I-87053W	I-87053	16-Ch DI (wet/dry, sink/source) Module
	I-8053PW		I-87053PW		16-Ch DI (wet/dry, sink/source) Module
			I-87053W-A5		16-Ch DI (wet/dry, sink/source) Module
			I-87053W-E5		16-Ch DI (wet/dry, sink/source) Module
			I-87053W-AC1		16-Ch DI (VAC) Module
	I-8058W	I-8058	I-87058W	I-87058	8-Ch DI (VAC) Module
		I-87059W		8-Ch DI (VAC) Module	
DO module	I-8037W	I-8037			16-Ch DO (Open Collector, source) Module
	I-8041W	I-8041	I-87041W	I-87041	32-Ch DO (Open Collector, sink) Module
	I-8041AW				32-Ch DO (Open Collector, source) Module
	I-8056W	I-8056			16-Ch DO (Open Collector, sink) Module
	I-8057W	I-8057	I-87057W	I-87057	16-Ch DO (Open Collector, sink) Module
	I-8060W	I-8060			6-Ch Power Relay Module
	I-8064W	I-8064	I-87064W	I-87064	8-Ch Power Relay Module
		I-8065	I-87065W	I-87065	8-Ch AC SSR Relay Module
		I-8066	I-87066W	I-87066	8-Ch DC SSR Relay Module
	I-8068W	I-8068	I-87068W	I-87068	8-Ch Power Relay Module
I-8069W	I-8069	I-87069W	I-87069	8-Ch PhotoMOS Relay Module	
DI & DO module	I-8042W	I-8042			16-Ch DI (wet, sink/source), 16-Ch DO (Open Collector, sink) Module
	I-8050W	I-8050			16-Ch universal DIO (wet, sink) Module
	I-8054W	I-8054	I-87054W	I-87054	8-Ch DI (wet, sink/source), 8-Ch DO (Open Collector, sink) Module
	I-8055W	I-8055	I-87055W	I-87055	8-Ch DI (dry, source), 16-Ch DO (Open Collector, sink) Module
	I-8063W	I-8063	I-87063W	I-87063	4-Ch DI (wet, sink/source), 4-Ch Power Relay Module
Counter module		I-8080			8-Ch Counter/Frequency Input Module
			I-87082W	I-87082	2-Ch Counter/Frequency Input Module

**Note: PROFI-8855 only support high profile I-8K and I-87K series I/O modules.**

## 5.6 Case Studies

### ► Vessel Propulsion Control and Monitor System

■ **Location:** Kaohsiung, Taiwan

■ **Product:** GW-7552

■ **Description:** The propulsion system is the most important and complex part of one ocean fishing vessels. It is composed of many electronic devices to control and monitor the engine speed, cooling system, residual fuel content, exhaust gas temperature, engine oil pressure, and so forth. Each of these devices may be handled by several PLCs via the different communication interfaces. In order to integrate the information from these devices, the user uses the GW-7552 for data-exchange between the Siemens PLC and the Modbus PLC. Therefore, the HMI can collect and configure the important parameters of the propulsion systems quickly and easily through the GW-7552.

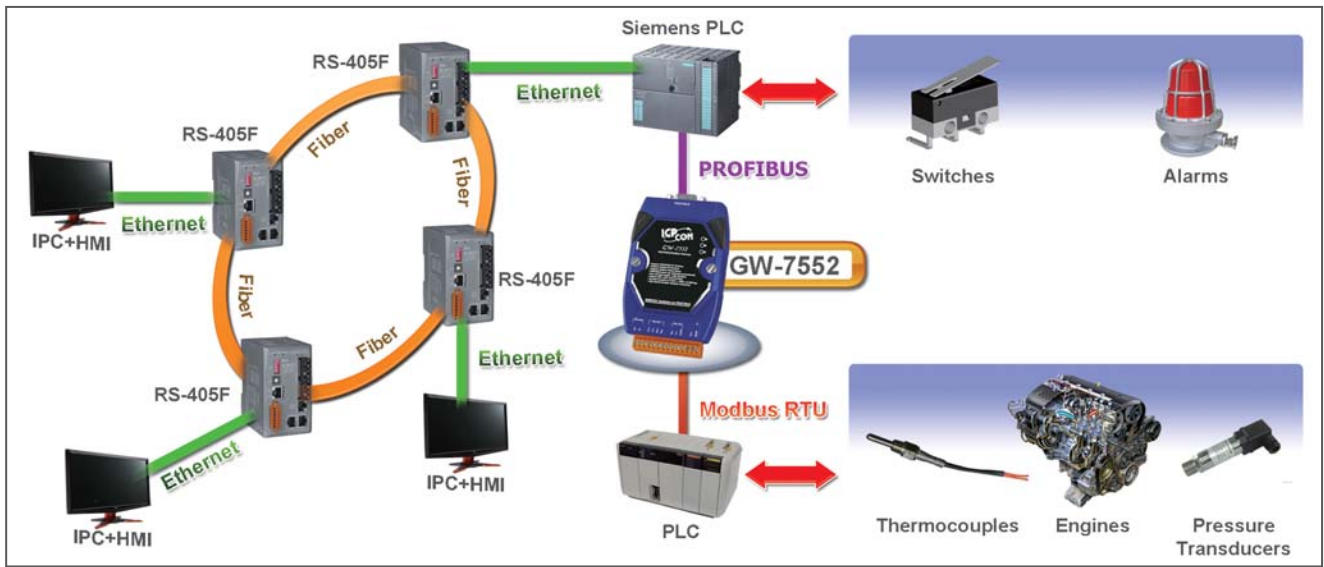

### ► High Temperature Industrial Furnaces Monitoring System

■ **Location:** China

■ **Product:** I-7550

■ **Description:** An industrial furnace refers to equipment which is used to provide heat for a certain process or reaction. Precise temperature profiles are absolutely mandatory for the often highly complex processes involved in firing, annealing and hardening of different materials. In order to achieve accurate and stable temperature control, the user use I-7550 to collect temperature information to ensure energy-optimized control of the processes.

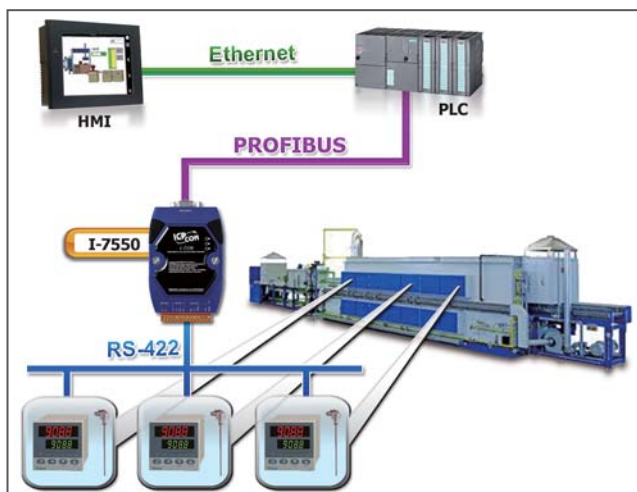

### ► Flow Control System

■ **Location:** Kaohsiung, Taiwan

■ **Product:** GW-7557

■ **Description:** Beverage manufacturers use flow meters whose communication interface of flow meter is HART to monitor flow production line. However, the other end communication interface of main controller is PROFIBUS. In order to integrate the information from flow meters, customer can use the GW-7557 to acquire data quickly and easily between main controller and flow meters.

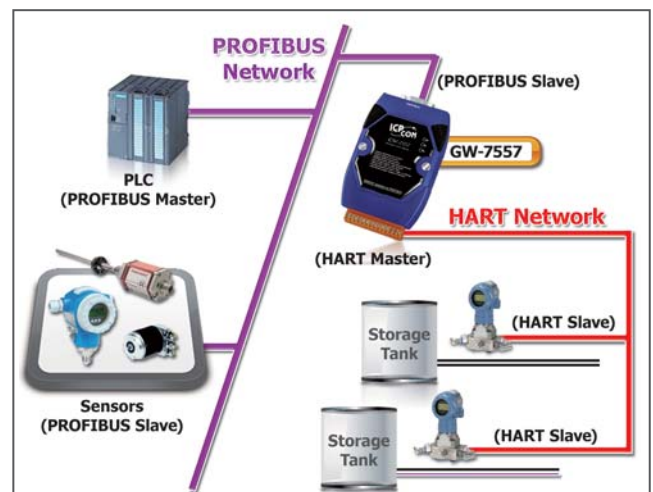

# HART Products



## 6.1 Overview

P 6-1

- Selection Guide ..... P 6-1

## 6.2 HART System Integration Solution

P 6-2

## 6.3 HART Products

P 6-3

- HART Converters ..... P 6-3
- HART Gateways ..... P 6-6
- HART Converter Features & HART Gateway Application ..... P 6-9
- HART I-8000 I/O Modules ..... P 6-10
- HART Signal Filter Modules ..... P 6-11

## 6.4 Case Studies

P 6-11



## 6.1 Overview

HART Field Communications Protocol extends this 4 ~ 20 mA standard to enhance communication with smart field instruments. The protocol preserves the 4 ~ 20 mA signal and enables two-way digital communications to occur without disturbing the integrity of the 4 ~ 20 mA signal. Unlike other communication technologies, the HART protocol can maintain compatibility with existing 4 ~ 20 mA systems with a uniquely backward compatible solution. Here are two main operational modes of HART instruments: analog/digital mode, and multi-drop mode

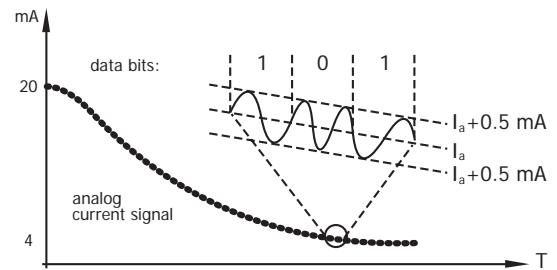

### ➤ Peer-to-Peer mode

The analog and digital signals can be communicated in this mode. Here the digital signals are overlaid on the 4 ~ 20 mA loop current. Both the 4 ~ 20 mA current and the digital signal are valid output values from the instrument. The polling address of the instrument is set to "0". Only one instrument can be put on each instrument cable signal pair.

### ➤ Multi-drop mode (digital)

In this mode, only the digital signals are used. The analog loop current is fixed at 4 mA. In multi-drop mode it is possible to have up to 15 instruments on one signal cable. The polling addresses of the instruments will be in the range 1 ~ 15. Each meter needs to have a unique address.

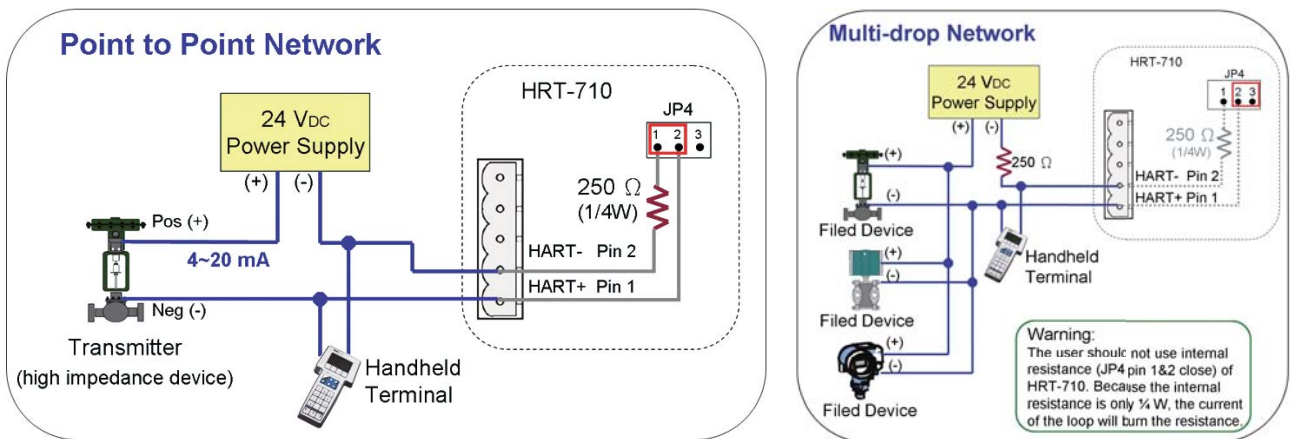

## Features:

- Compatibility with standard 4 ~ 20 mA wiring
- HART is a no risk solution for enhanced field communication
- Risk reduction through a highly accurate and robust protocol
- Relatively easy to understand and use, the HART protocol provides access to the wealth of additional information (variables, diagnostics, calibration, etc.)
- Increase plant Availability
- Improve regulatory compliance
- Simultaneous transmission of digital data

## Selection Guide

Model Name	Description
<b>Converter</b>	I-7547 Ethernet to HART Converter
	I-7567 USB to HART Converter
	I-7570 RS-232/422/485 to HART Converter
	HRT-227CS HART to Single Mode Fiber Converter
	HRT-328-A4 HART-to-Analog Converter and Loop Monitor
<b>Gateway</b>	HRT-710 Modbus RTU/ASCII Slave to HART Master Gateway
	HRT-310 Modbus RTU/ASCII Slave to HART Master Gateway (Upright)
	HRT-711 Modbus TCP Slave to HART Master Gateway
	GW-7557 PROFIBUS DP Slave to HART Master Gateway
<b>Remote I/O Unit</b>	I-87H17W 8-Ch Current Input HART Master Module, for PAC
	I-87H24W 4-Ch Current Output HART Master Module, for PAC
<b>Signal Filter</b>	HRT-370 HART Signal Filter with one AI and one HART channel

## 6.2 HART System Integration Solution

ICP DAS have deeply researched on the HART bus technology for many years. The total HART products have been developed by ICP DAS including HART converter, HART gateway and HART I/O modules. The HART converter can be used to access HART devices via COM, USB or Ethernet interface. The HART gateway can integrate HART communication to the different protocols like Modbus, PROFIBUS etc. The HART I/O module can be used to access or control HART devices directly. Therefore, by using ICP DAS HART products, users can easily and quickly integrate HART devices and complete the data acquisition to SCADA, HMI or PLC system.

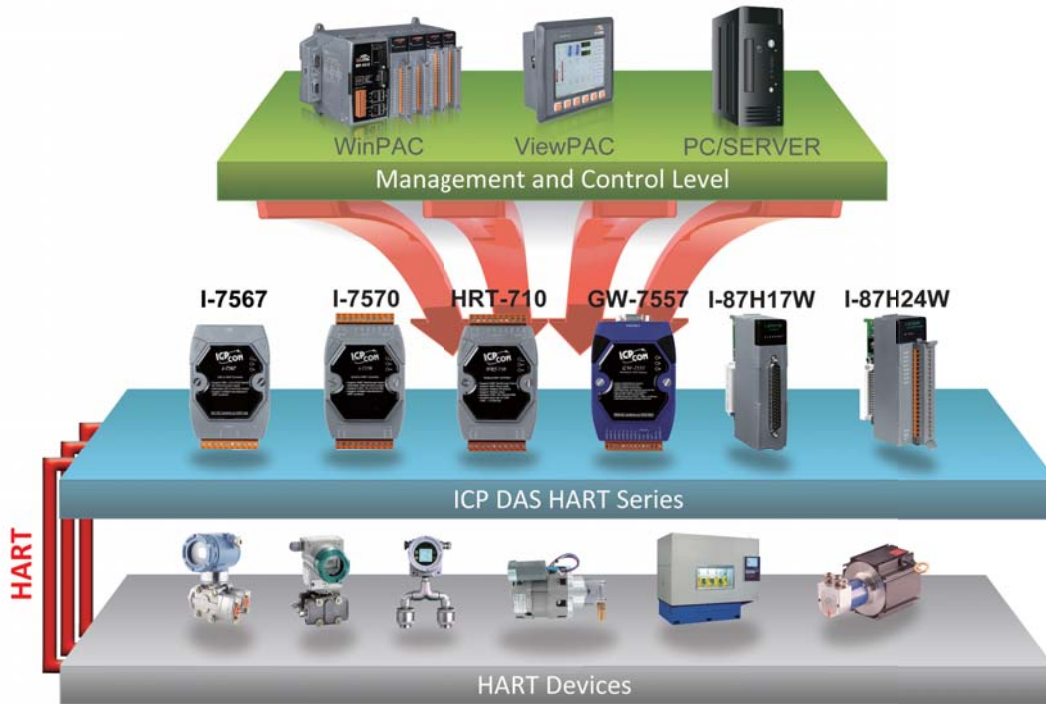

The following diagram will illustrate the HART bus applications and understand the roles of ICP DAS HART communication modules in HART network.

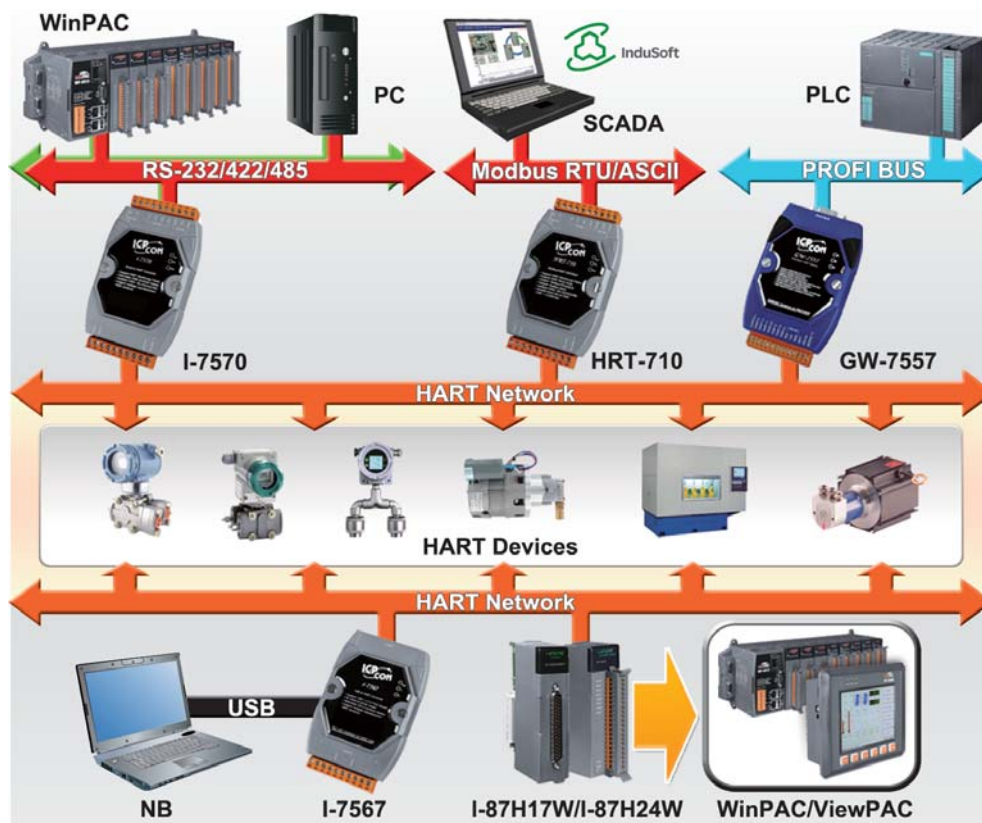

## 6.3 HART Products

### HART Converters

NEW

#### Ethernet to HART Converter

##### I-7547



The I-7547 is an Ethernet to HART converter designed as the master device of HART protocol. It allows users to access the HART slave via Ethernet. These HART slave devices may be a transmitter, actuator, current output device and so forth. In addition, by using the HC\_Tool utility, users can configure module and test HART communication easily and quickly.

#### Features >>>

- Support HART Short/Long frame
- Support HART Burst mode
- Support point-to-point or multi-drop HART mode
- Support connecting up to 15 HART slave devices
- Allow two HART masters
- Support firmware update via Ethernet
- Provide PWR/TxRx indication LED
- 4 kV ESD Protection
- Selectable 250 Ω load resistor
- Provide four HART channels
- Support HART Pair-Connection (FW\_v1.03)
- Support FDT (Field Device Tool) technology

#### Utility Features >>>

- Search all HART devices automatically
- Provide HART Universal & Common-Practice command (v6.0) for HART device configuration
- Provide module configuration and HART
- Provide data logging for HART communication



6

HART

#### USB to HART Converter

##### I-7567



I-7567 is a USB to HART converter specially designed as the master device of HART protocol. Through it, users can easily access the HART network via USB port which is implemented as a virtual COM port on PCs or notebooks. Because the I-7567 is powered by the USB interface, the external power is not necessary. Moreover, the I-7567 provides the Utility tool which is helpful for diagnosing and configuring the HART network.

#### Features >>>

- Support HART Short/Long frame
- Support HART Burst mode
- Allow two HART masters
- 4 kV ESD protection
- Support firmware update via USB
- 3000 VDC intra-module isolation
- Provide selectable 250 Ω load resistor
- Allow to connect with Max. 15 HART modules
- Compatible with USB 1.1 and 2.0 standards
- Powered by USB (external power is not necessary)
- Support FDT (Field Device Tool) technology (like: PACTware/FieldCare/Seimens PDM...)
- Support HART OPC Server provided by HART COMMUNICATION FOUNDATION (HCF)
- Support the in point-to-point or multi-drop HART network mode

#### Utility Features >>>

- Search all HART devices automatically
- Provide HART Universal & Common-Practice command (v6.0) for HART device configuration
- Provide module configuration and HART
- Provide data logging for HART communication



## RS-232/422/485 to HART Converter

### I-7570



The I-7570 is a Serial to HART converter specially designed as the master device of HART protocol. By using I-7570, the HART devices, such transmitters, actuators, gauges, meters, and the current output devices, can be easily integrated into the HMI/PLC/PC devices via serial port which may be RS-232/RS-422/RS-485 interface. In order to diagnose and configure the HART network more easily, the I-7570 Utility tool with friendly configuration interface is given. It is helpful for diagnosing and configuring the HART network.

### Features ▶▶▶

- Support HART Short/Long frame
- Support HART Burst mode
- Allow two HART masters
- Allow to connect with Max. 15 HART modules
- Provide selectable 250 Ω load resistor
- Isolated COM 1: 3-wire RS-232/RS-422/RS-485
- Support firmware update via COM1
- Provide PWR/RUN/ERR LED indicators
- 4 kV ESD protection
- Support FDT (Field Device Tool) technology (like: PACTware/FieldCare/Seimens PDM...)
- Support HART OPC Server provided by HART COMMUNICATION FOUNDATION (HCF)
- Support the in point-to-point or multi-drop HART network mode

### Utility Features ▶▶▶

- Search all HART devices automatically
- Provide HART Universal & Common-Practice command (v6.0) for HART device configuration
- Provide data logging for HART communication

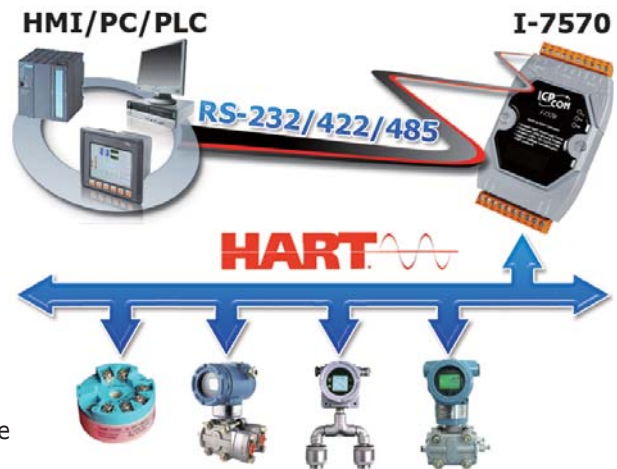

## HART to Single Mode Fiber Converter

### HRT-227CS



The HRT-227CS is a HART to Fiber converter paired used to extend HART communication distance via single mode fiber optic transmission medium. In order to solve the problem between HART and fiber transmission medium, HRT-227CS is specially designed for converting the HART signal to fiber optic cables. Built-in a HART 250 Ω loop resistor adjustable by dip switch. Therefore, users can make data collection and processing of HART network easier and quicker by applying HRT-227CS. In addition, we also provide the free HC\_Tool utility for module configuration easily.

### Features ▶▶▶

- Support HART Short/Long frame
- Support HART Burst mode
- Allow two HART masters
- Fiber broken line detection
- 4KV ESD Protection
- Selectable 250Ω loop resistor
- Support firmware update via COM port
- Support point-to-point or multi-drop HART mode
- Support connecting up to 15 HART slave devices
- Fiber Type: SC ; Single mode ; 100 Base-FX
- Fiber max. transmission distance up to 30 km
- The HART port with the same Group ID can communicate with each other

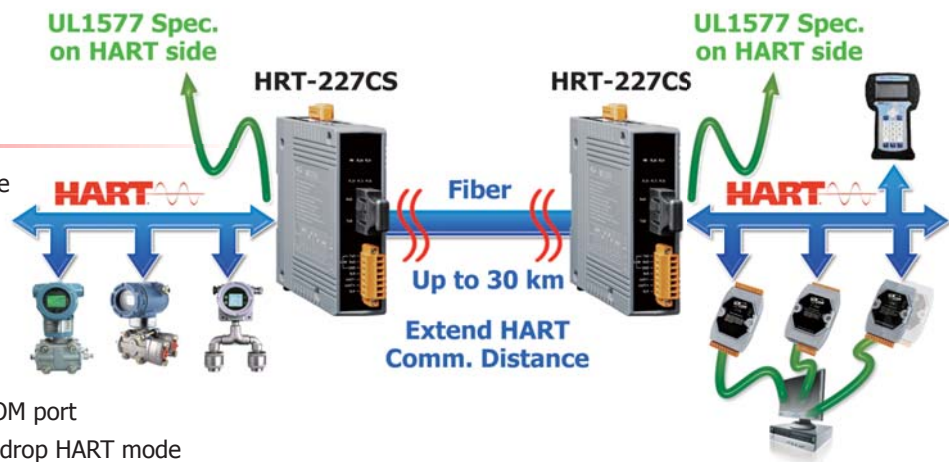

## HART-to-Analog Converter and Loop Monitor

**HRT-328-A4** The ICPDAS HRT-328-A4 HART Loop Converter enables the conversion of a digital multivariable HART signal into four independent 4 ~ 20 mA analog process variables. The HRT-328-A4 can apply in control or monitoring application to obtain up to four additional analog outputs without additional process penetrations.



The HRT-328-A4 allows up to four additional analog process variables from a multivariable transmitter or valve with no additional process penetrations. Besides, installed transparently across the 4~20 mA instrument loop, the HRT-328-A4 reads the HART digital process data that rides on the loop wires. The HRT-328-A4 converts the digital information for up to four isolated analog process signals that are readily accepted by in-place control system, such as DCS or PLC.

The HRT-328-A4 not only converts multivariable into analog process signal but also monitors the multivariable under/over limit intelligently. There are 4 built-in user programmable alarm output for monitoring. When a variable of transmitter under or over the user defined limit, the programmable alarm will activate automatically without DCS or PLC.

### Features >>>

- Support HART Short/Long frame
- Support HART Burst mode
- Allow two HART Masters
- Working in Point-to-Point Mode
- 4 Independent Analog Output Signals
- Support Firmware Update
- Provide LED indicators
- Built-in 2 Form A and 2 Form C relays
- Intelligent Activate Relay Alarm automatically
- Support Acquire Long Frame Address Automatically

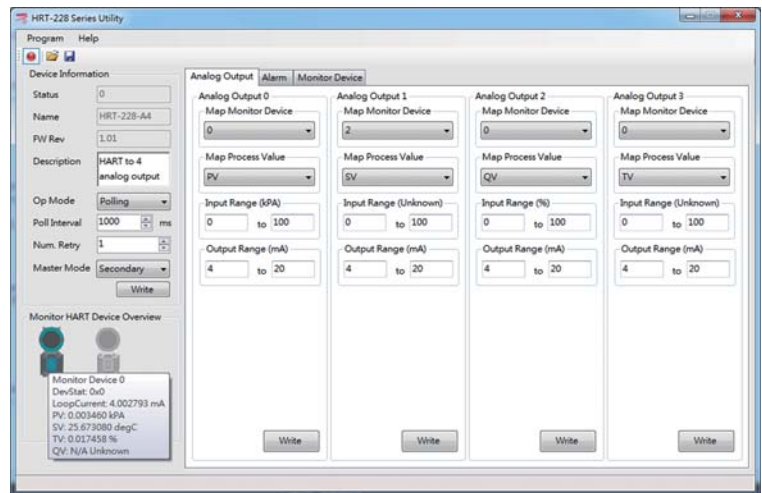

6

HART

### Utility Features >>>

- Provide the configuration of HRT-328-A4
- Provide the diagnostic information of HRT-328-A4 module and HART device
- Provide send HART command transparently to HART device
- Provide "Load/Save" module configuration file to apply to other HRT-328-A4 quickly

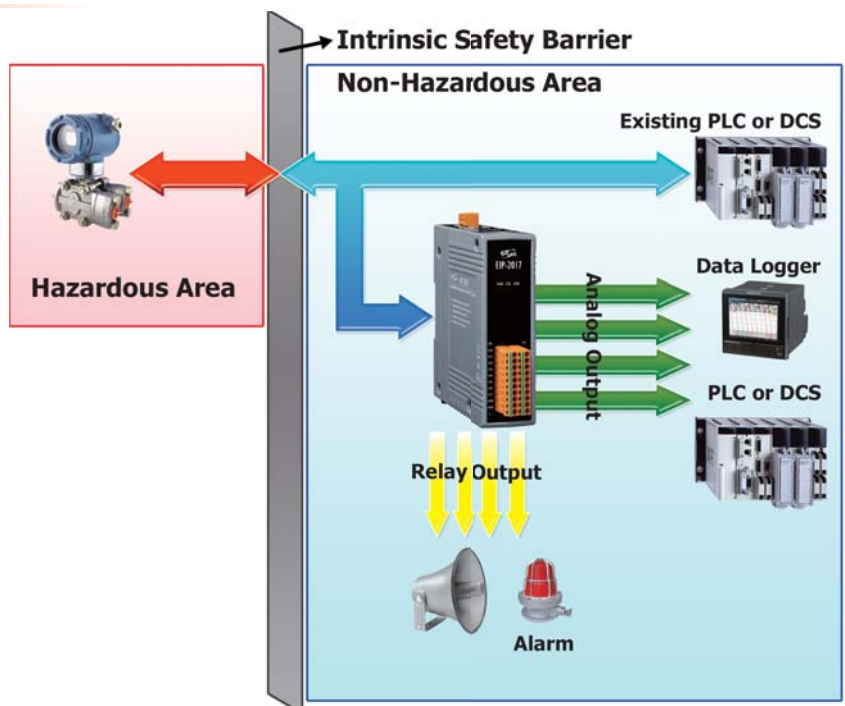





## Modbus RTU/ASCII Slave to HART Master Gateway

### HRT-710



### HRT-310



The HRT-710/HRT-310 is a Modbus RTU/ASCII slave to HART master gateway. It provides an economic solution for Modbus master device to access the HART slave devices. In order to diagnose and configure the HART network more easily, the HG\_Tool Utility with friendly configuration interface is given.

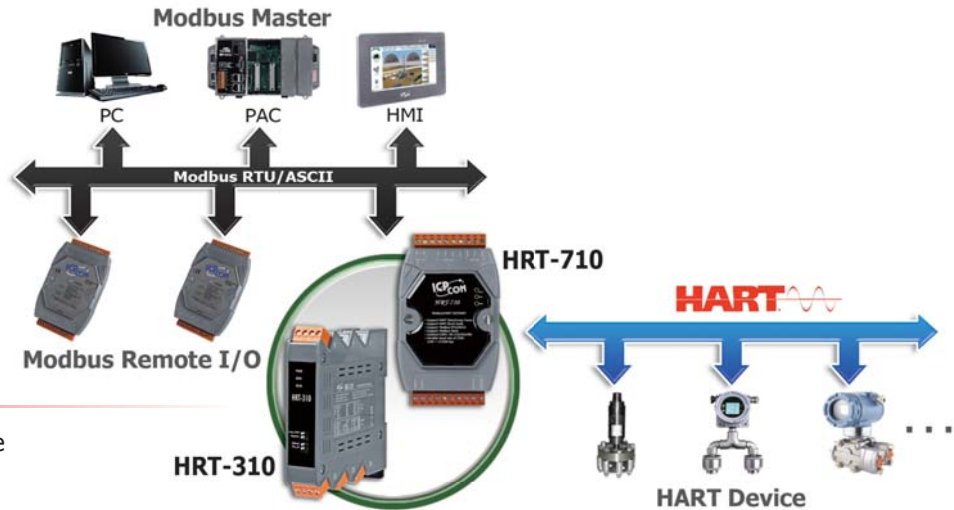

### Features >>>

- Support HART Short/Long frame
- Support HART Burst mode
- Allow two HART Masters
- Support Modbus Slave mode
- Provide LED indicators
- Isolated COM 1: RS-232/422/485
- Connecting up to 15 HART modules
- Support Modbus RTU and ASCII format
- Working in point-to-point or multi-drop HART mode
- Support firmware update via Com Port (FW\_v1.2 and HW\_v1.2)
- Support on-line replacement of HART devices (FW\_v1.5)
- Support acquire Long Frame Address automatically (FW\_v1.5)

### Utility Features >>>

- Provide the system and communication configuration of HRT-710
- Provide the Modbus address table for HART command data
- Provide the diagnostic information of HRT-710 module and HART device
- Provide send/receive HART command to access HART device
- Provide "Load/Save" module configuration file to apply to other HRT-710 quickly



	HRT-710	HRT-310
<b>Din Rail Installation</b>	Horizontal	Upright
<b>HART Signal</b>	Standard	Enhanced for send/recv Signal (For long distance comm.)
<b>Loop Power</b>	No	Support
<b>Built-In Resistor</b>	250 Ohm (1/4W)	250 Ohm (1W)

NEW

## Modbus TCP Slave to HART Master Gateway

### HRT-711



The HRT-711 is a new Modbus/TCP to HART Gateway. It allows the Modbus/TCP Master to access the HART Slave devices. These HART devices may be a transmitter, an actuator, a current output device and so forth. By using the HRT-711, users can integrate their HART devices into Modbus network easily. Therefore, HRT-711 can be a powerful gateway to exchange the data between Modbus and HART network. Moreover, the HRT-711 can be applied in the various hard environments because its high isolation protection designs. This design makes users to apply widely application for the remote data acquisition, control, process automation, and factory automation, etc.

### Features >>>

- Support HART Short/Long frame
- Support HART Burst mode
- Allow two HART Masters
- Working in point-to-point or multi-drop HART mode
- Connecting up to 15 HART modules
- Support Modbus TCP
- Support Modbus Slave mode
- Support firmware update via Com Port
- Support on-line replacement of HART devices
- Support acquire Long Frame Address automatically



### Utility Features >>>

- Provide the system and communication configuration of HRT-711
- Provide the Modbus address table for HART command data
- Provide the diagnostic information of HRT-711 module and HART device
- Provide send/receive HART command to access HART device
- Provide "Load/Save" module configuration file to apply to other HRT-711 quickly

6

HART

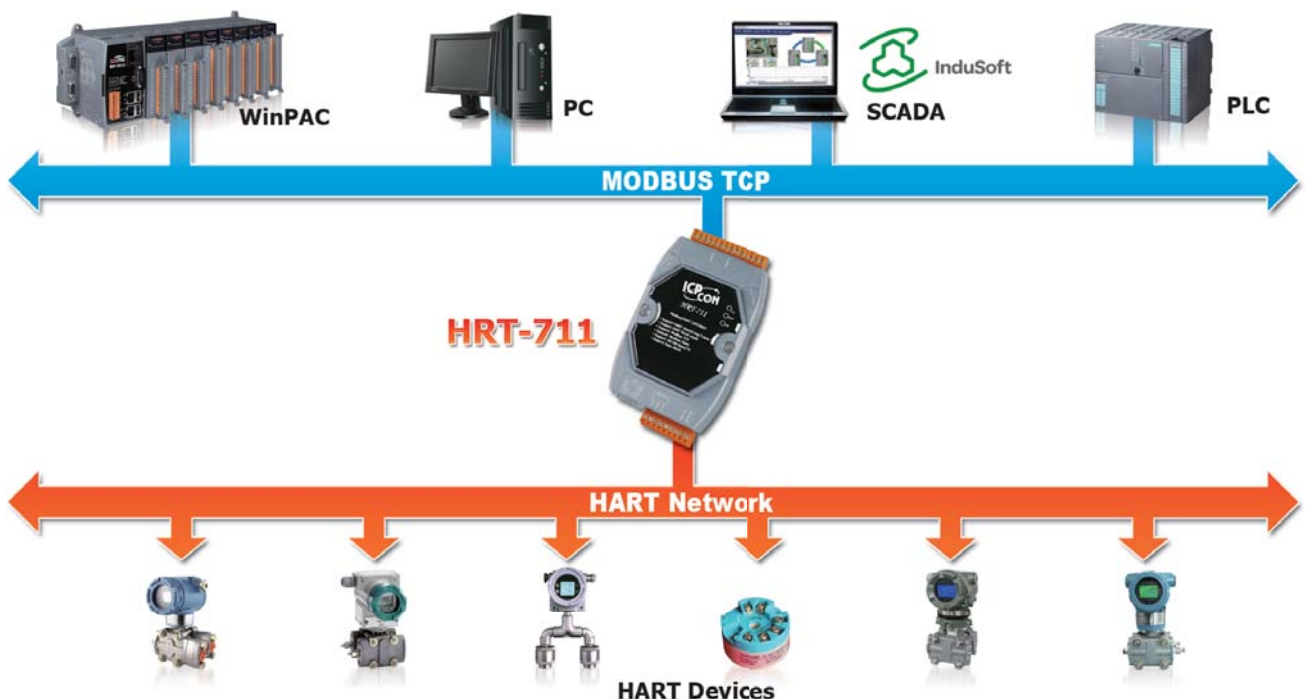

## PROFIBUS DP Slave to HART Master Gateway

### GW-7557



The GW-7557 is designed for the slave device of PROFIBUS DP protocol. It allows the PROFIBUS master to access the HART slave devices. These HART devices may be a transmitter, an actuator, a current output device and so forth. Owing to the GW-7557, you can put the HART slave devices into PROFIBUS network very easily.

### Features >>>

- Support PROFIBUS DP-V0 slave
- Protocol & Hierarchy: DP-V0 Slave
- Detect transmission rate (9.6 ~ 12000 kbps) automatically
- Max transmission speed up to 12 Mbps for PROFIBUS and 115.2 kbps for COM Port
- Max I/O Data Length: 240/240 Bytes
- Support 4 HART Channels
- Support HART Short/Long frame
- Support HART Burst mode
- Allow two HART Masters
- Working in point-to-point or multi-drop HART mode
- Connecting up to 15 HART modules
- Network Isolation Protection: High Speed iCoupler
- 3000 VDC isolation protection on PROFIBUS side
- 4 kV ESD Protection

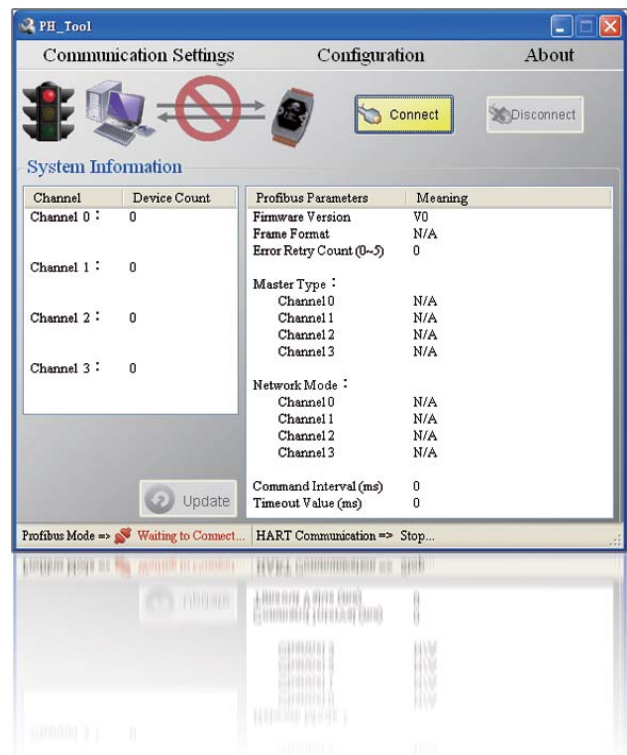

### Utility Features >>>

- Read/Write module configuration of the
- Provide auto-scan function for HART communication parameters
- Provide test function for HART slave devices
- Show PROFIBUS user parameters of the GW-7557

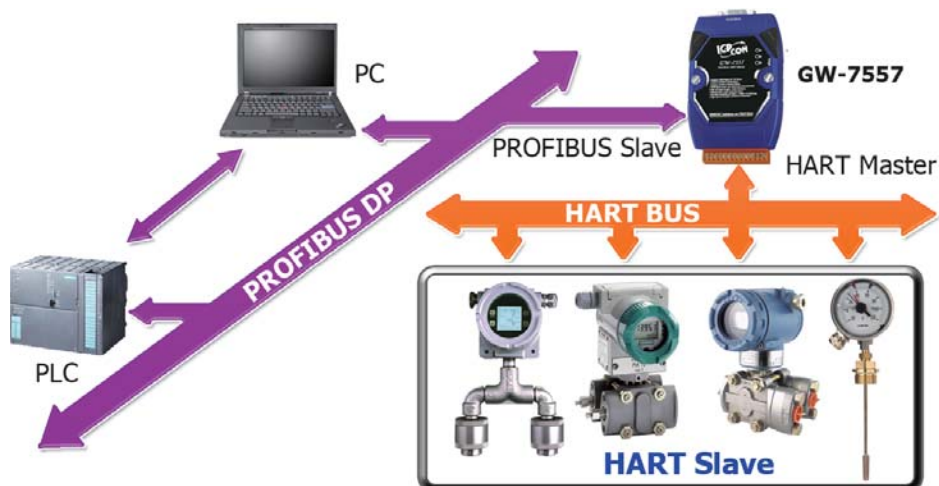

### HART Converter Features

- (1) Provide Free Software Tool : (HC\_Tool)=> Support HART devices for searching and configuration and communication record.
- (2) Support HART OPC Server=> Integrate HART data to SCADA or HMI easily and quickly.
- (3) Support FDT (Field Device Tool) Software.

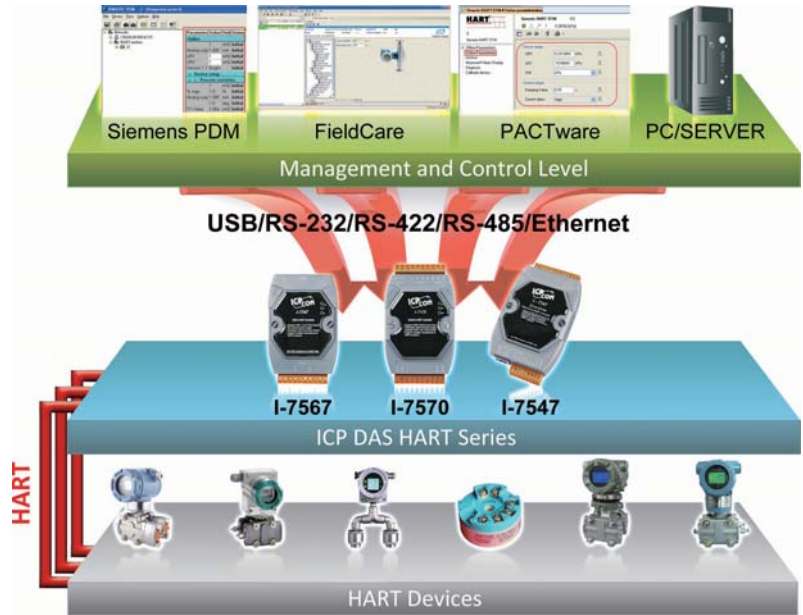
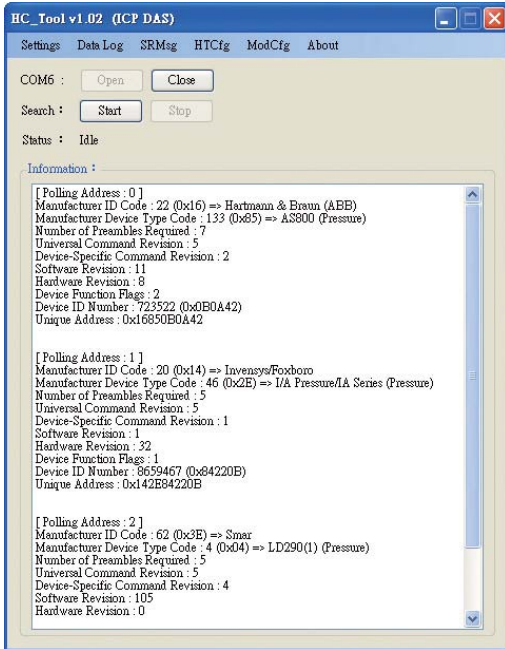

6

HART

### HART Gateway Application

Integrate about 200 HART devices by using HRT-710 via RS-485 with 24 ports to PC and fiber for distance extension.

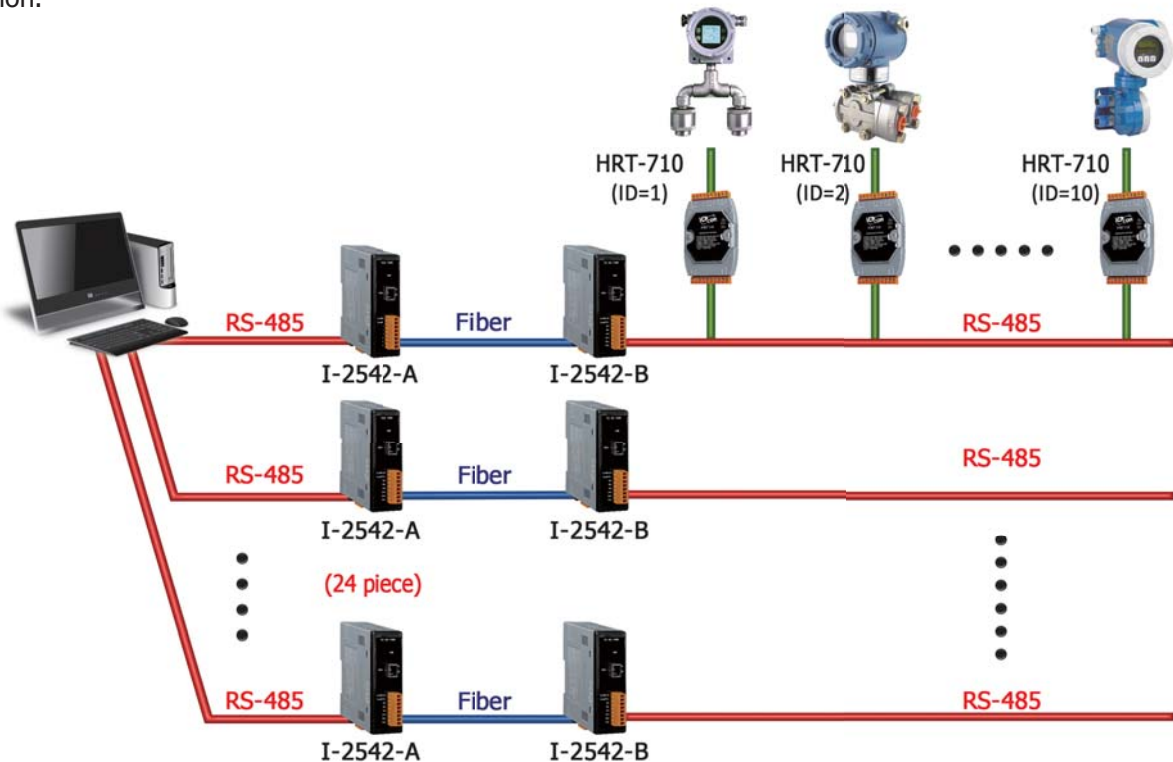



## HART I-8000 I/O Modules

### 8-Ch Current Input HART Master Module

#### I-87H17W



The I-87H17W is an 8-Ch HART analog input module. It can measure 4~20 mA current and act as a HART master, allowing communication with HART field devices. Users can measure current directly without any external resistor. The I-87H17W adopts DCON protocol and can be used in WinPAC, ViewPAC, XPAC, LinPAC and iPAC series PAC.

- Open wire detection
- Support 4 ~ 20 mA current input
- 2-wire or 4-wire transmitters of HART
- Allow to connect with Max. 15 HART modules
- 4 kV ESD protection, and 2500 VDC intra-module isolation
- Support the in point-to-point or multi-drop HART network mode
- Support HART Short/Long frame
- Support HART Burst mode
- Support DCON protocol
- Allow two HART masters
- Support DCON protocol

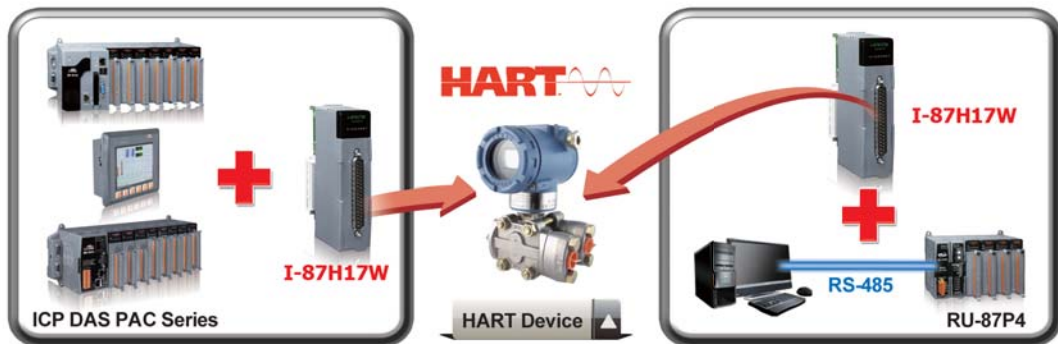

Available soon

### 4-Ch Current Output HART Master Module

#### I-87H24W



The I-87H24W is a 4-Ch HART analog output module. It can output 4~20 mA current and be as a HART master, allowing communication with HART field devices. The I-87H24W supports DCON protocol defined by ICP DAS, and can be used in WinPAC, ViewPAC, XPAC, LinPAC and iPAC series PAC.

- Open wire detection
- 2-wire transmitters of HART
- Support 4 ~ 20 mA current output
- Allow to connect with Max. 15 HART modules
- 4 kV ESD protection, and 2500 VDC intra-module isolation
- Support the in point-to-point or multi-drop HART network mode
- Support HART Short/Long frame
- Support HART Burst mode
- Support DCON protocol
- Allow two HART masters

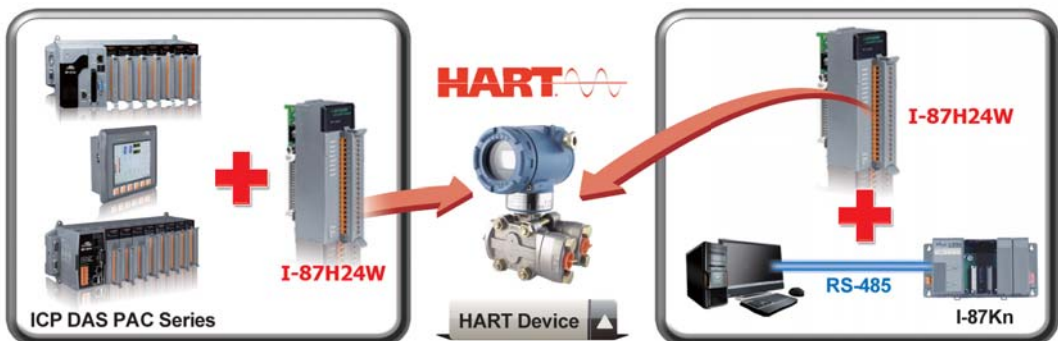

**HART Signal Filter Modules**

Available soon

**HART Signal Filter**

**HRT-370**



HRT-370 can receive a 4 to 20 mA DC current signal from HART device or control system analog output and passes the signal bi-directionally and uninterruptedly. Besides, HRT-370 also provides a HART interface to communicate with HART device. By using HRT-370, it can effectively isolate the HART device communication signal from control system analog signal.

- Support the in point-to-point or multi-drop HART network
- Allow to connect to the Max. 15 HART modules
- Support 4 ~ 20 mA current input
- 2-wire or 4-wire transmitters of HART
- Support HART Short/Long frame
- Support HART Burst mode
- Allow two HART masters
- Provide LED indicators

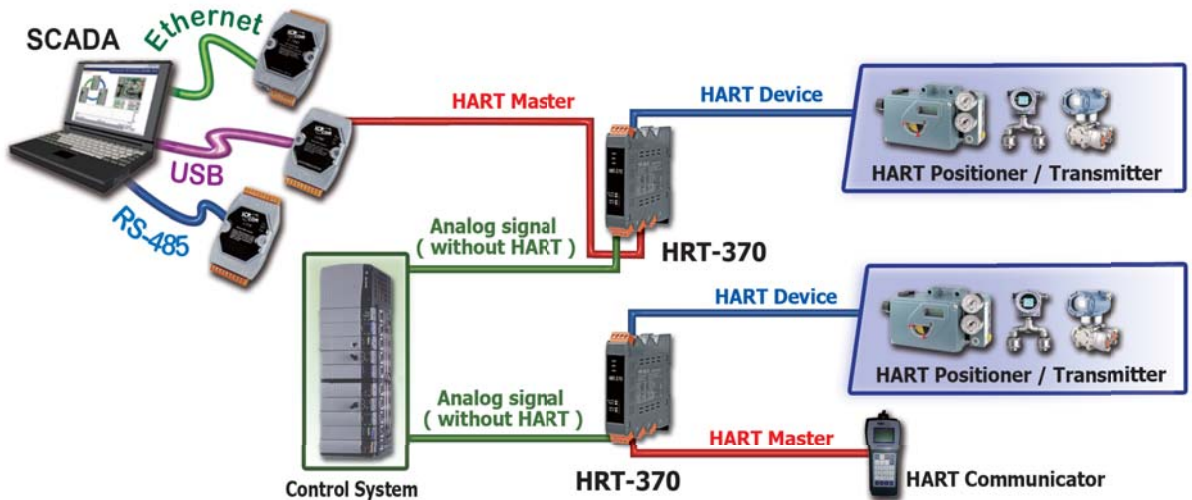

6

HART

**6.4 Case Studies**

**Pressure Detection of Gas Pipeline**

In general, the process of the natural gas transported to users' families requires long-distance pipeline. The gas pressure in the pipeline will be reduced gradually from high to medium until low. If the gas pipeline ruptures and nobody knows it, it will cause the great loss of company. Further, it even causes the more serious disaster. So the most important mission for gas transportation system is strict control of the gas pipeline pressure. The gas company uses HART bus manometer for stable measurement and easy maintenance. The XPAC-8000 controller and I-87H17W with eight HART AI channels are used to collect these HART manometers data quickly and easily. Through Ethernet, the control center can monitor all gas pipeline pressure remotely.

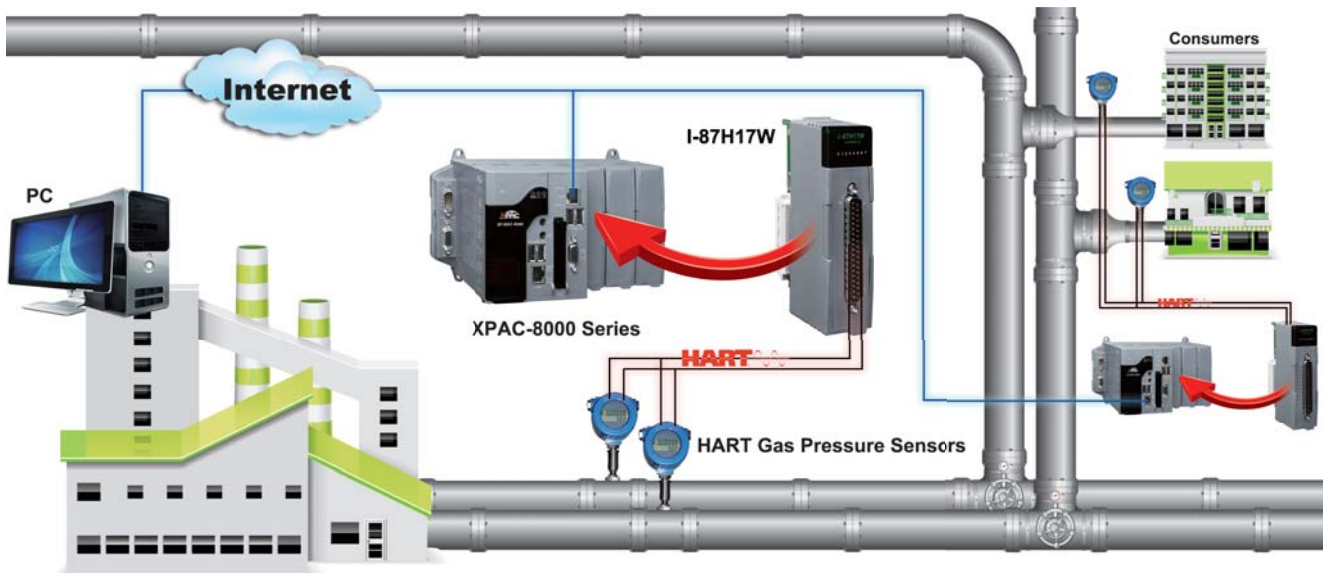

# M-Bus



## 7.1 Overview P7-1

- Selection Guide ----- P 7-1
- M-Bus Converter ----- P 7-2
- M-Bus Repeater ----- P 7-2
- M-Bus Gateway ----- P 7-3



## 7.1 Overview

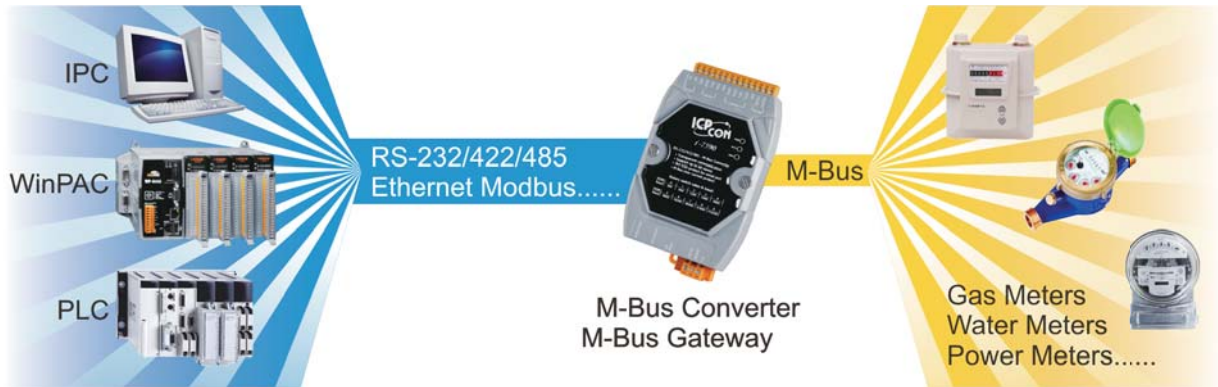

The M-Bus ("Meter-Bus") is a European standard for remote reading of meters. It is usable for most types of consumption meters as well as for various sensors and actuators.

The M-Bus was developed to fill the need for a system for the networking and remote reading of utility meters in the home. This bus fulfills the special requirements of remotely powered or battery-driven systems. When interrogated, different from the classical manual reading, the meters deliver the data they have collected to a common master, such as a PAC, connected at periodic intervals to read all utility meters of a building.

### M-Bus remotely meter reading system

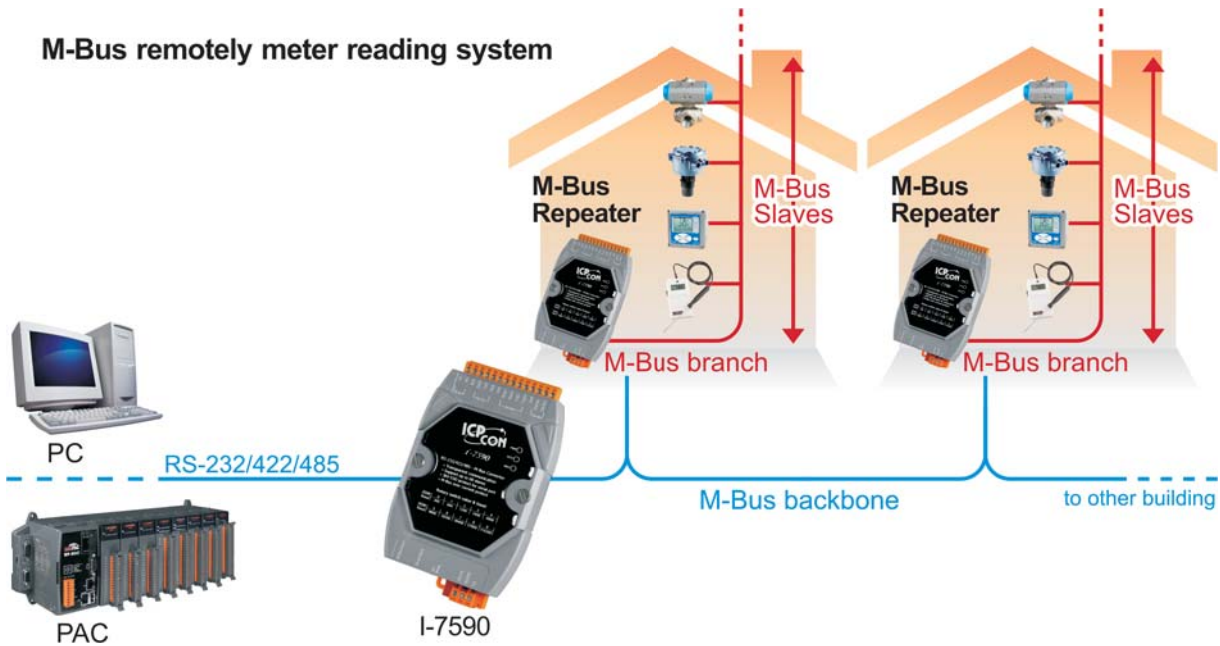

### Features:

- Large number of connectable devices
- Possibility for network expansion
- Fail-safe characteristics/robustness
- Minimum cost
- Minimum power consumption in the meters
- Acceptable transmission speed

### Applications:

- Automatic meter reading system
- Remotely powered system
- Types meters integrated application

### Selection Guide

Models		Description
M-Bus converter	I-7590	RS-232/422/485 to M-Bus converter
M-Bus Repeater	I-3591	M-Bus Repeater
M-Bus gateway	GW-7828	Modbus RTU slave to M-Bus master gateway
M-Bus gateway	GW-7838	Modbus TCP server to M-Bus master gateway





## M-Bus Converter

NEW

### RS-232/422/485 to M-Bus converter

#### I-7590



The I-7590 is specially designed for M-Bus slave device. It offers RS-232, RS-422 and RS-485 three kinds of communication way. For the hardware of the I-7590, it has two rotary switches for serial port and M-Bus port baud rate. This design allows master baud rate to be different from the M-Bus slave baud rate. For the communication of the I-7590, it uses transparent communication. It solves the problem when performing protocol conversion between the master and the slave, and makes the communication easier. I-7590 is perfect for use when a new M-Bus device is added to an old RS-485 network or when the master firmware and configuration required not being changed.

- Baud rate: Adjustable by rotary switch from 300 to 115200 bps
- Overcurrent and short-circuit protection on the M-Bus
- Provide PWR, MTX and MRX 3 LED indicators
- 4 kV ESD protection on the serial port
- Default M-Bus port data format: Data bit 8, Parity even, Stop bit 1
- Default serial port data format: Data bit 8, Parity none, Stop bit 1
- Update firmware from serial port
- Support up to 100 M-Bus slaves
- Provides transparent communication

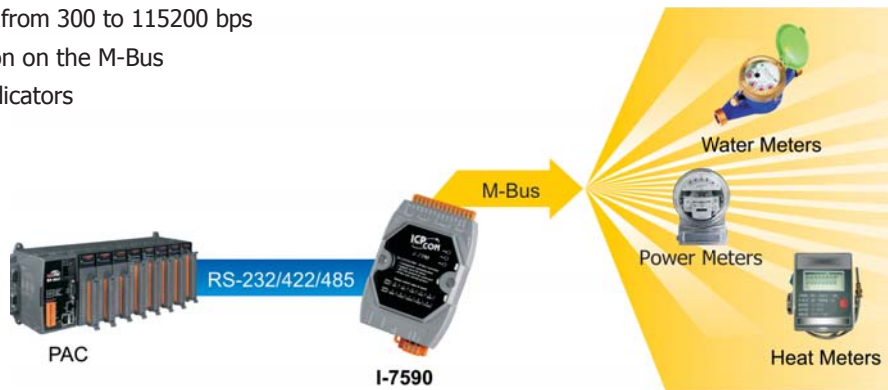

#### Pin Assignments >>>

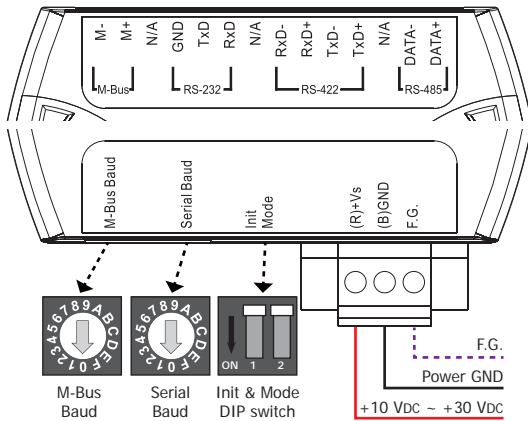

#### Rotary & DIP Switch >>>

Switch Value	0	1	2	3	4	5
Baud (bps)	300	600	1200	2400	4800	9600
Switch Value	6	7	8	9	A ~ F	
Baud (bps)	19200	38400	57600	115200	User-defined	

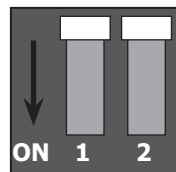

1 Init	2 Mode	Description
OFF	OFF	Run Firmware
OFF	ON	Configure
ON	OFF	Update Firmware



## M-Bus Repeater

Available soon

### M-Bus Repeater

#### I-3591



The I-3591 is a M-bus repeater which could be a component of the M-bus system. It is designed for use in plants where extensive bus lines are required, or where large numbers of meters need to be connected, for example in district heat networks that supply heat to entire sections of towns.

- M-Bus to M-Bus Repeater
- Supports M-Bus slaves: 100
- Overcurrent detection
- Duplicate node id detection
- M-Bus Baud rate: Automatic baud rate detection
- M-Bus Data Format: Automatic data format detection



**M-Bus Gateway**

**Modbus RTU to M-Bus Gateway**

**GW-7828**

The GW-7828 gateway is a Modbus RTU slave device that allows the Modbus RTU master to access the M-Bus slave devices. These M-Bus devices may be a water meter, electric meter, power meter and so forth. Owing to the GW-7828, you can put the M-Bus slave devices into Modbus network very easily.



- Wide range of power input (+10 VDC ~ +30 VDC) and operating temperature (-25°C ~ +75°C)
- Support command request mode and cyclic request mode
- Modbus RTU baud rate: Support from 300 to 115200 bps
- Overcurrent and short-circuit protection on the M-Bus
- M-Bus baud rate: Support from 300 to 115200 bps
- Provide PWR, MTX/RX and ERR 3 LED indicators
- Support com port configure
- 4 kV ESD protection on the serial port
- Support up to 100 M-Bus slaves

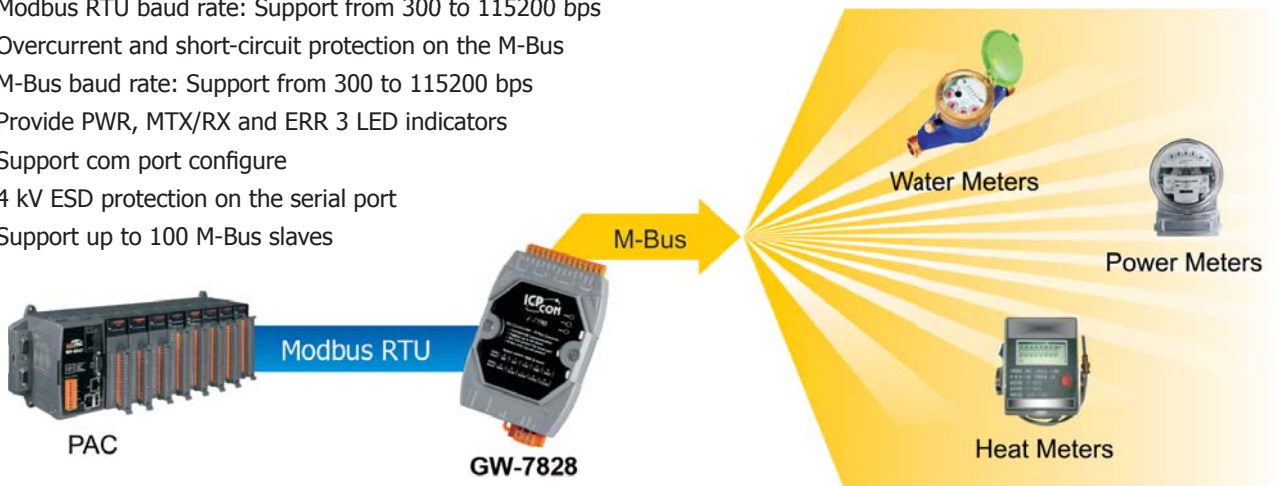

7

M-Bus

Available soon

**Modbus TCP to M-Bus Gateway**

**GW-7838**

The GW-7838 gateway is a Modbus TCP server device that allows the Modbus TCP client to access the M-Bus slave devices. These M-Bus devices may be a water meter, electric meter, power meter and so forth. Owing to the GW-7838, you can put the M-Bus slave devices into Modbus TCP network very easily.



- Support command request mode and cyclic request mode
- Overcurrent and short-circuit protection on the M-Bus
- M-Bus baud rate: Support from 300 to 115200 bps
- Provide PWR, MTX/RX and ERR 3 LED indicators
- Support com port and Ethernet configure
- 4 kV ESD protection on the serial port
- Support up to 100 M-Bus slaves

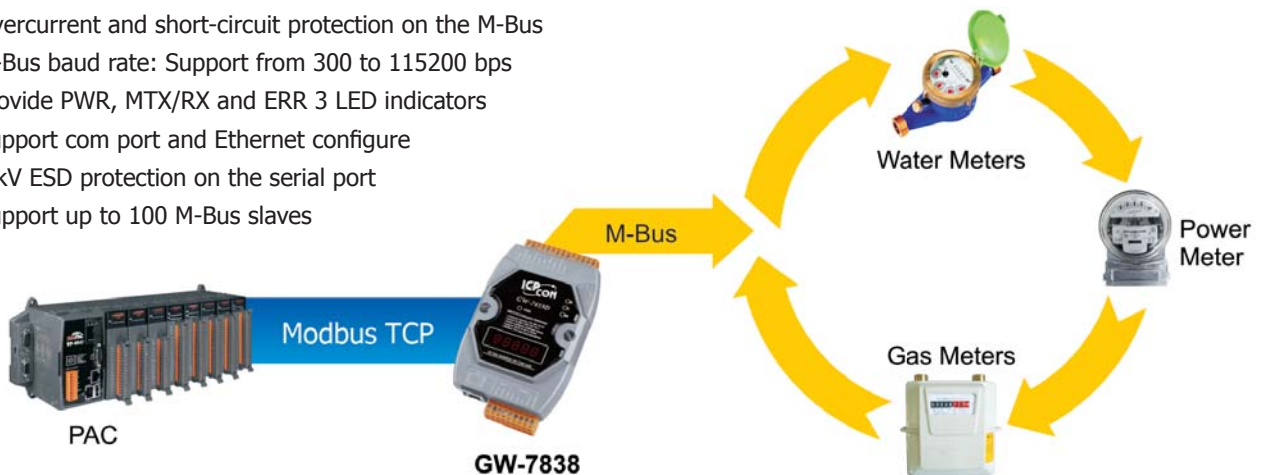



# G-4513-3GWA Serial

## Power Saving PAC for M2M Applications



### FEATURES

- ⌚ Sleep mode for energy saving and backup battery
- ♻️ Built-in Solar Panel charging circuit
- ☑️ Configurable sleep mode for maximum power savings.
- ❓ Automatic power supply selection - constant power supply, solar cell, or backup battery
- 📶 Integrated GPS/3G function in the controller

**Go Green!**

# ICP DAS Catalogs & Brochure

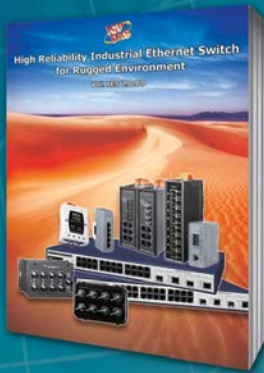

## High Reliability Industrial Ethernet Switch Catalog

- Managed Ethernet Switches
- Unmanaged Ethernet Switches
- PoE Ethernet Switches
- Media Converters
- Real-time Redundant Ring Ethernet Switches
- IP67 Waterproof Switches
- Cyber-Ring Ethernet Self-healing Technology



## ICP DAS Product Catalog

- 7188/7186, 5000, ViewPAC, Compact PAC
- Industrial Panel PC, Touch Monitor
- SmartView, TouchPAD, ViewPAD, IWS
- RS-485, Ethernet and WISE I/O Products
- CAN Bus, PROFIBUS and FRnet Products
- Multi-serial Card, Serial Device Server
- Managed and Unmanaged Ethernet Switch
- Radio Modem, 2G/3G, WLAN/ZigBee, GPS
- Ethernet, PC/PAC-based Motion Control
- Energy Management and Power Meter
- PCI Express, PCI and ISA DAQ Boards



## PAC Products Catalog

- XP-8000-Atom Series
- XP-8000 Series
- WP-8000 Series
- LP-8000 Series
- IP-8000 Series
- ViewPAC Series
- MotionPAC Series
- I/O Expansion Units
- I/O Modules
- 5000 Series
- 7188/7186 Series
- Redundant System

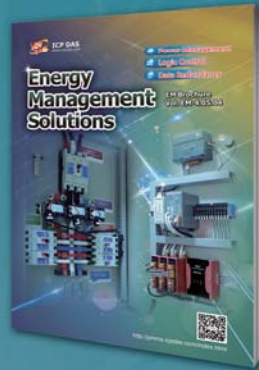

## Energy Management Solutions - EM Brochure

- True RMS Input Module
- TouchPAD - VPD series
- Smart Power Meter
- Smart Power Meter Concentrator
- Power Data Management Software



## Remote I/O Modules and I/O Expansion Units Products Catalog

- RS-485 Products
- Ethernet Remote I/O Modules
- FRnet I/O Modules
- CAN Bus Products
- PROFIBUS Remote I/O Modules
- HART Products
- Smart Power Meter
- WISE I/O Module

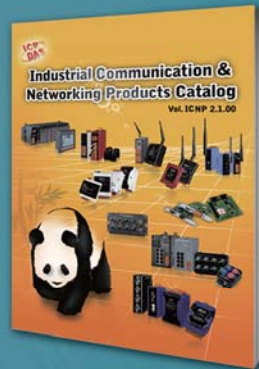

## Industrial Communication & Networking Products Catalog

- Multi-port Serial Cards
- Programmable Device Servers (Serial-to-Ethernet)
- Converters, Repeaters and Hubs
- Fieldbus Solutions
- Ethernet Switches



## A Web-based Intelligent PACController - WISE Brochure

- Intelligent Multifunction IoT Controller
- Intelligent Data Logger I/O Controller
- Intelligent I/O Module



## PC-based I/O Boards Catalog

- PCI Express Data Acquisition Boards
- PCI Bus Data Acquisition Boards
- ISA Bus Data Acquisition Boards
- Special Function Boards
- Daughter Boards and Accessories



**ICP DAS CO., LTD.**

**Taiwan (Headquarters)**

TEL: +886-3-597-3366

FAX: +886-3-597-3733

e-mail: [info@icpdas.com](mailto:info@icpdas.com)

[sales@icpdas.com](mailto:sales@icpdas.com)

**Local Distributor**



<http://www.icpdas.com>