

ICP DAS Building Automation Products - The LC Family: Particulars and Applications

By Tony Lee

Using the ICP DAS TPD master controller in conjunction with members of the LC family results in a well-connected system that matches the standards that could be required for any building. Using the HMIWorks WYSIWYG philosophy, you can spend more time actually doing things, instead of worrying about how things should be done. Discard the pesky menial stage, and focus instead on pure design, and observe as the result polishes itself.

For nearly two decades ICP DAS has proven itself time and again, working closely with customers to continually identify creative outcomes to a range of problems, supply tailored solutions for individual needs, and provide a stream of innovation that continues to enhance its reputation. In recent years, ICP DAS has turned to the field of building automation, now offering the easy-to-install and robust LC family of products.

Applications for the LC Family

In an office (or home) environment, how can the LC family of products be used to meet high automation standards? All that is actually needed in order to smoothly create just such a system is a TPD touch screen connected to one or more of the LC products .

The ICP DAS TPD controller is equipped with built-in high resolution

touch screen, real-time clock (RTC) and other communication interfaces such as: RS-232, RS-485, Ethernet, USB, and line-out connections.

The RS-485 interface can be connected to an LC product, a connection established to communicate with HMIWorks, and you can get straight to work in performing building automation tasks. The HMIWorks graphical library drastically shortens setup time, thereby speeding up system

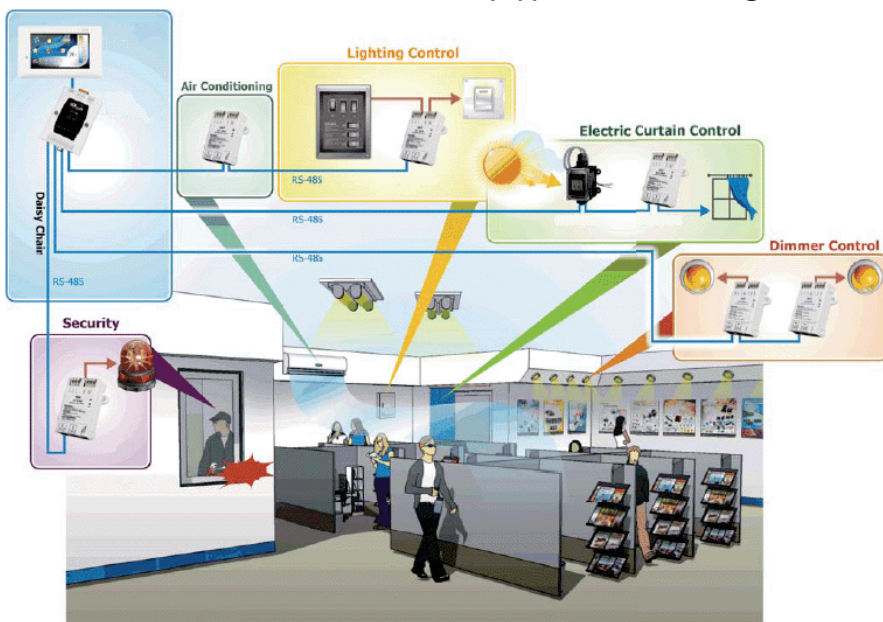

deployment. The WYSIWYG nature of HMIWorks lets the user actually get things done, as opposed to wondering how to get them done. Shedding the layer of complicated coding greatly streamlines the process and makes for a ideal end result.

After that brief introduction to the TPD controller, let's now examine some of the LC family of products:

The simplest method of managing lighting requirements is to use the LC-101 model. Options are provided that allow either familiar physical switches or the TPD to be used to remotely control the lighting.

The TPD can also be configured to follow predefined rules, for example, switching off at a given time in order to save energy. For the average user - whether corporate or private - the LC-101 will definitely ensure that the working environment is much more convenient.

For finer management of lighting control, ICP DAS presents the LC-221, which provides the added capability of operating dimmers. The LC-221 thus takes energy management a step further, removing the need for additional energy that would otherwise be wasted.

In residential applications, the IR-210/712 infrared model can be used to control a wide range of household appliances that support IR codes. These can all connected and converted to a standard protocol so that they can be used by remote-controlled or programmable touch screens, thus fulfilling most monitoring needs. By adding the LC-312 temperature and humidity controller to create an intelligent air conditioning system, home life can be vastly improved.

For home security applications, the LC-131 can be connected to reed switches, glass break detectors, and many other kinds of sensors. Together with open-circuit detection, the result is a truly reliable security system.

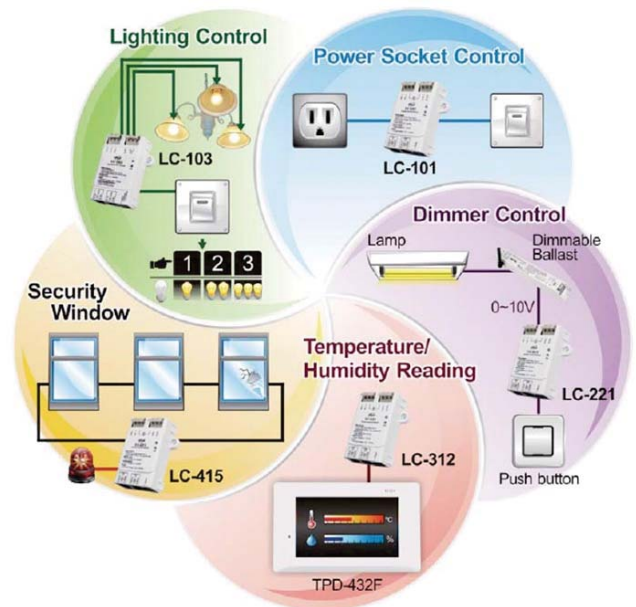

Note that there are a number of other modules in active development, including an illuminometer, a 360-degree infrared detector, and a 4-channel lighting control module, all of which will be available in the near future.

Let's now explore the LC family in greater detail.

Features of the LC Product Line

All devices in the LC Family:

- I Are easy to install and debug in the field. The RJ-11 6P connector provides power and communication connections, and the spring clamp terminal block for the IO interface work together to make installation much easier, saving customers a lot of time usually spent on verification.



RS-485 and Power Input Daisy Chain using an RJ-11 Connector

- II Come with full support for configuring both hardware and software. Both are quick and flexible, making them suitable for a variety of needs. The user is at liberty to decide how difficult things can be made, depending on the application.
- III Simplify the division of work. Once the LC module is installed, it can be operated immediately with

nothing special needing to be done to customize the software. Consequently, there is no need to wait for engineers to write control and verification programs. Maintenance or adjustment are both easy and flexible, and the system is robust enough to deal with any potential faults without the need to take the device out of service.

Maintenance costs are reduced and schedules can be eased thanks to the flexibility of the system; even without a controller, normal operations of the system are not compromised.

IV Support standard protocols and a variety of transmission formats. LC series modules can operate using either the DCON or Modbus RTU protocol. They also can work with N81, E71, O71, and N82 data formats, and communication speeds can range from 1200 to 115200 bps.

Detailed Documentation for LC Product Functions

I LC-101 Light Control Module: This module is used to toggle between on and off using a high load relay output and a channel control switch input. An application block diagram is shown below:

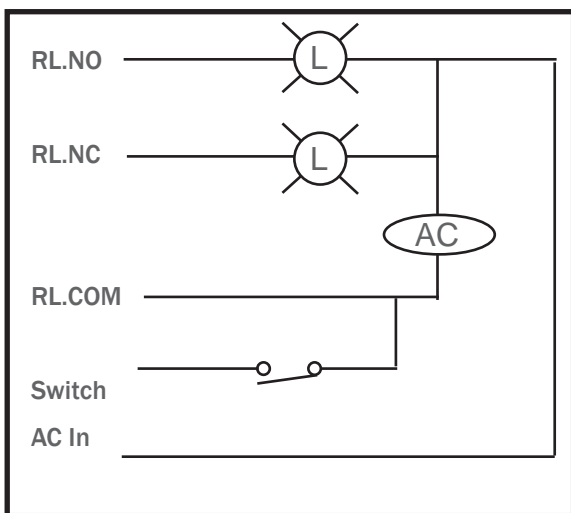

When the "Switch AC In" pin detects a change, the relay output status will change immediately without needing to pass through software control.

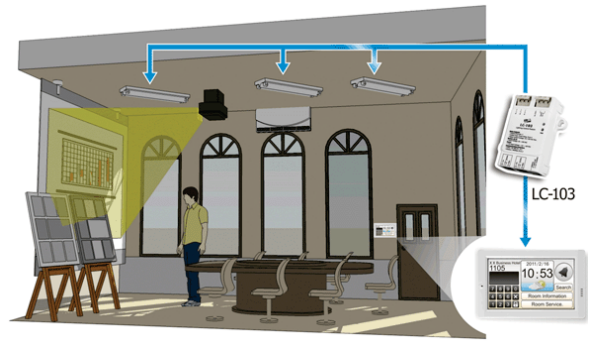

II LC-221 Dimmer Module: This module features one channel for analog output, one channel to turn lights on and off (with relay output), and a channel control switch input. An application block diagram is shown below:

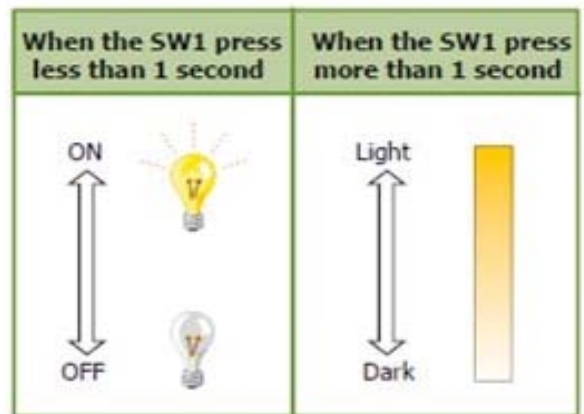
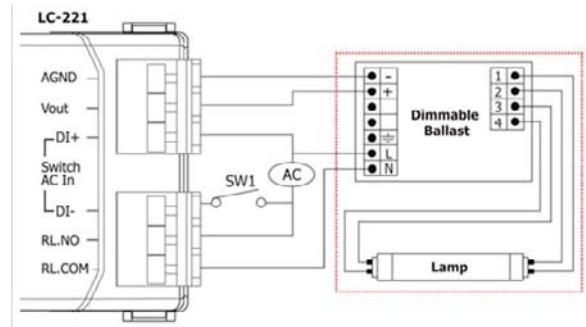

The LC-221 analog output is used to control dimmer switches connected to light sources. The "Switch AC In" pin can be connected to a control switch, which can be used manipulate fluorescent lights depending on the length of time the switch is pressed, for example, pressing for <1 sec. will switch the lights on or off, whereas pressing for >1

sec. will set the dimmer controls.

- III **LC-131:** This module includes open circuit detection with three digital input channels and one high-load relay output channel. The input channels can be used for open circuit detection and, when connected, access control devices can provide a reliable source. Relay output channels can also be used to connect to a buzzer, so that when an open circuit is detected, a user-defined event is generated that triggers the alarm, effectively deterring vandalism or theft.

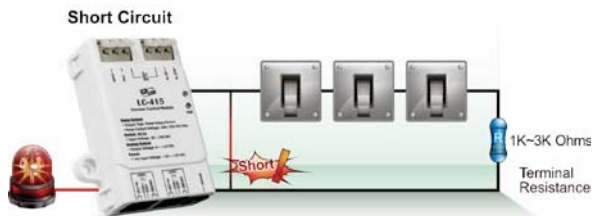

- IV **LC-312:** This module contains temperature and humidity sensors that provide real-time monitoring of both values and includes an internal clock, which makes for easy collection of room temperature and humidity data, facilitating management of systems

such as air conditioning.

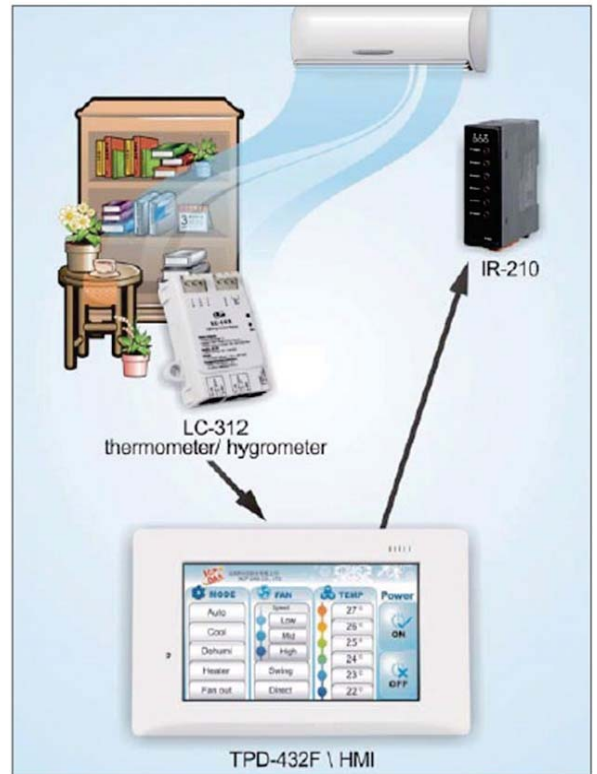

- V **IR-210/712:** This infrared learning module acts as an interface with household appliances via infrared transmission and can be programmed to "learn" specific features. It provides a standard communication protocol that can be linked with remote controls or programmable touch panels, and is the perfect addition to the management of a "Smart House."
- VI **LC-485 RS-485 Star Wiring Hub:** This device can be used to solve the numerous complications that exist when wiring a network. Application details are shown below:

