



I-8017HW-G I-8017HCW-G I-8017DW-G

8-channel Analog Input Module

Features

- 8 Differential/16 Single-ended Analog Inputs
- Voltage or Current Input
- 14-bit 100 kHz AD Converter
- Internal/External Trigger
- Individual Channel Configuration
- ± 4 kV ESD Protection
- 2500 Vrms Intra-module Isolation
- Wide Operating Temperature Range: $-25 \sim +75$ °C



Introduction

The I-8017HW, I-8017DW and I-8017HCW are high performance Analog Input Module. Up to 16 single-ended or 8 differential input channels are provided with 14-bit of resolution and 90 kS/s sampling rate. Each channel can be configured to an individual input range of ± 10 VDC, ± 5 VDC, ± 2.5 VDC, ± 1.25 VDC or ± 20 mA. The modules also provide ± 4 kV ESD protection as well as 2500 Vrms intra-module isolation.

All the three modules can be used to measure voltage and current source. On the I-8017HW, an external 125 Ω resistor is needed to measure current source, while on the I-8017DW and I-8017HCW, an internal resistor is jumper-selectable for differential current input. The jumper is factory default setting for voltage measurement on the I-8017DW, and is setting for current measurement on the I-8017HCW.

System Specifications

Model	I-8017HW	I-8017HCW	I-8017DW
LED Indicators/Display			
System LED Indicator	1 LED as Power Indicator		
I/O LED Indicator	16 LEDs as Status Indicator		
Isolation			
Intra-module Isolation, Field-to-Logic	2500 Vrms		
EMS Protection			
ESD (IEC 61000-4-2)	± 4 kV Contact for each Terminal		
Power			
Power Consumption	2 W Max.		
Mechanical			
Dimensions (W x L x H)	30 mm x 102 mm x 115 mm	30 mm x 85 mm x 114 mm	
I/O Connector	20 Pin Terminal Block	D-Sub 37 Pin	
Environment			
Operating Temperature	$-25 \sim +75$ °C		
Storage Temperature	$-40 \sim +85$ °C		
Humidity	10 ~ 90% RH, Non-condensing		

I/O Specifications

Model	I-8017HW	I-8017HCW	I-8017DW
Analog Input			
Channels	16-ch Single-ended/ 8-ch Differential		
Voltage Input Range	± 10 VDC, ± 5 VDC, ± 2.5 VDC, ± 1.25 VDC		
Current Input Range ± 20 mA	Requires Optional External 125 Ω Resistor	Jumper Selectable	
Resolution	14-bit		
Sample Rate	Single Channel Polling Mode: 90 kS/s Single Channel Interrupt Mode: 50 kS/s 8 channel Scan Mode: 16 kS/s		
Accuracy	$\pm 0.1\%$ of FSR		
Zero Drift	± 0.1 μ V/°C		
Span Drift	± 10 ppm/°C		
Input Bandwidth	100 kHz		
Input Impedance	20 K, 200 K, 20 M (Jumper Selectable)		
Individual Channel Configuration	Yes		

Pin Assignments

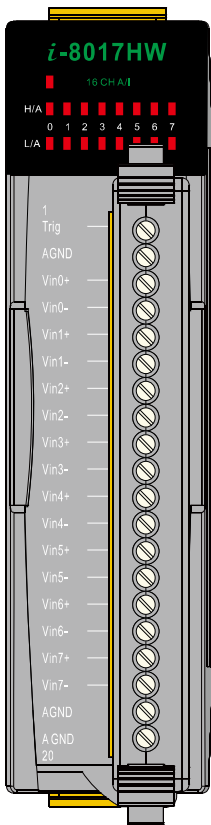

Terminal No.	Pin Assignment	
	Differentia	Single-ended
01	Trig	Trig
02	AGND	AGND
03	Vin0+	Vin0
04	Vin0-	Vin8
05	Vin1+	Vin1
06	Vin1-	Vin9
07	Vin2+	Vin2
08	Vin2-	Vin10
09	Vin3+	Vin3
10	Vin3-	Vin11
11	Vin4+	Vin4
12	Vin4-	Vin12
13	Vin5+	Vin5
14	Vin5-	Vin13
15	Vin6+	Vin6
16	Vin6-	Vin14
17	Vin7+	Vin7
18	Vin7-	Vin15
19	AGND	AGND
20	AGND	AGND

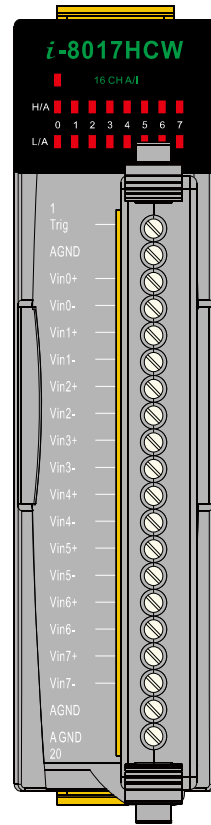

Terminal No.	Pin Assignment	
	Differentia	Single-ended
01	Trig	Trig
02	AGND	AGND
03	Vin0+	Vin0
04	Vin0-	Vin8
05	Vin1+	Vin1
06	Vin1-	Vin9
07	Vin2+	Vin2
08	Vin2-	Vin10
09	Vin3+	Vin3
10	Vin3-	Vin11
11	Vin4+	Vin4
12	Vin4-	Vin12
13	Vin5+	Vin5
14	Vin5-	Vin13
15	Vin6+	Vin6
16	Vin6-	Vin14
17	Vin7+	Vin7
18	Vin7-	Vin15
19	AGND	AGND
20	AGND	AGND

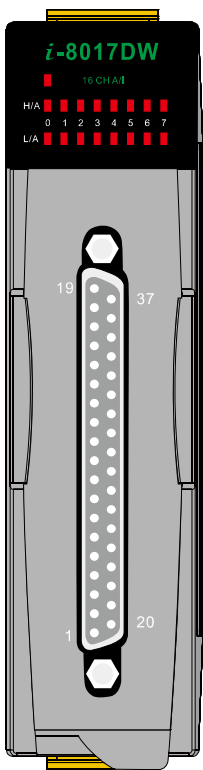

Pin Assignment		Terminal No.	Pin Assignment		
Differentia	Single-ended		Differentia	Single-ended	
AGND	AGND	19	37	BK Sensor	BK Sensor
Trig	Trig	18	36	-	-
AI7-	AI15	17	35	-	-
AI7+	AI17	16	34	-	-
AI6-	AI14	15	33	-	-
AI6+	AI6	14	32	-	-
AI5-	AI13	13	31	-	-
AI5+	AI5	12	30	-	-
AI4-	AI12	11	29	-	-
AI4+	AI4	10	28	-	-
AI3-	AI11	09	27	-	-
AI3+	AI3	08	26	-	-
AI2-	AI10	07	25	-	-
AI2+	AI2	06	24	-	-
AI1-	AI9	05	23	-	-
AI1+	AI1	04	22	-	-
AI0-	AI8	03	21	AGND	AGND
AI0+	AI0	02	20	AGND	AGND
BK Sensor	BK Sensor	01			

Input Type Select

JP2 for I-8017HW
JP1 for I-8017HCW
I-8017DW

Differential input
Single-ended input

Input Impedance Select

Vin+ JP3 for I-8017HW
I-8017HCW
I-8017DW

10M 100K 10K

Vin- JP4 for I-8017HW
JP2 for I-8017HCW
I-8017DW

10M 100K 10K

■ Dimensions (Units: mm)

I-8017HW/I-8017HCW

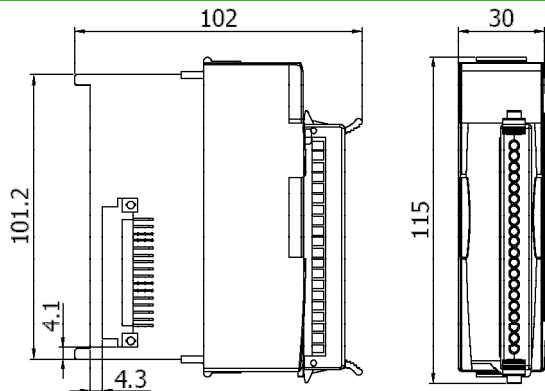

Left View

Front View

I-8017DW

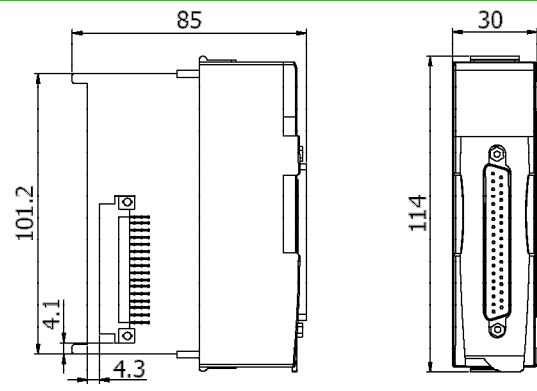

Left View

Front View

■ Wire Connections

I-8017HW		
Input Type	Differential	Single-ended
Voltage Input Wiring		
Current Input Wiring		
Note: When connecting to a current source, an optional external 125 Ω resistor is required.		

I-8017HCW, I-8017DW		
Input Type	Differential	Single-ended
Voltage Input Wiring		
Current Input Wiring		
Note: Differential Input Type: Current Input Wiring need to jumper at current input. Single-ended Input Type: Current Input Wiring need to jumper at voltage input, an options external 125 Ω resistor is required.		

■ Internal I/O Structure

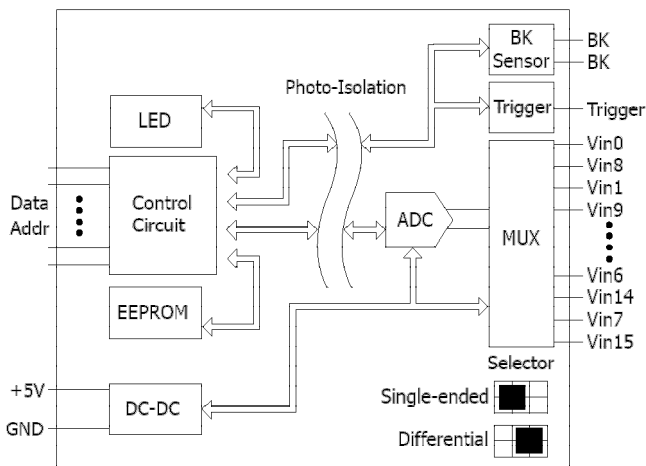

■ Accessories

	2AB125R	125 Ω, 0.1% DIP Resistor used for Current Type Input Modules
	SG-770 CR	7-channel Differential or 14-channel Single-ended Surge Protector (RoHS)
	SG-3000 Series	Signal Conditioning Modules for Thermocouple, RTD, DC Voltage, DC Current and Power Input
	DN-37 Series	I/O Connector Block with DIN-Rail Mounting and 37-pin D-Sub Connector (pitch: 5.08 mm)
	DN-37-381 Series	I/O Connector Block with DIN-Rail Mounting and 37-pin D-Sub Connector (pitch: 3.81 mm)
	CA-3705A/ CA-3710A/ CA-3715A	Male-Female D-Sub cable 0.5/1/1.5 M

■ Ordering Information

I-8017HW-G CR	8-channel Analog Input Module, 20 Pin Terminal block (Current Input Mode: Requires Optional External 125 Ω Resistor) (Gray Cover) (RoHS)
I-8017DW-G CR	8-channel Analog Input Module, 20 Pin Terminal block (Current Input Mode: Jumper Select) (Gray Cover) (RoHS)
I-8017HCW-G CR	8-channel Analog Input Module, D-Sub 37 Pin (Current Input Mode: Jumper Select) (Gray Cover) (RoHS)