

## Specific Applications

New Generation of Power Management Solution

OPC UA: New Generation Technology of the Standard Industrial Communication

WISE-5231 Intelligent Multifunction IoT I/O Concentrator

Residential/Commercial Building Leakage Monitoring Application

Lighting and Air Conditioning Management System in Hospital

PAC in Railway Signaling Application





























ZigBee Application - Emergency Bell Alarm System

ZigBee Application - Route Management System for AGV



# Industrial Internet of Things

## WIRELESS

DSSS RF	2G/3G/4G	WLAN	ZigBee	GPS	IR
 SST-2450	 GTM-203 Series	 Wi-Fi Bridge	 ZigBee Converters	 GPS Receivers	 IR Modules
 DSSS RF	 2G/3G/4G	 WLAN	 ZigBee	 GPS	 IR
 RF-87Kn	 G-4500 Series	 I-7540D-WF	 ZigBee I/O	 Train	 Air Conditioner
 CNC Machine	 GT-500 Series	 M2M-711D	 ZigBee Repeater	 Public Transportation	 Projector
 Meters	 Truck	 Barcode Reader	 Remote Controller	 Cruise	 Sound

## Fieldbus Solutions

CAN	DeviceNET	CANopen	J1939	M-Bus	PROFIBUS	PROFINET	EtherCAT	Ethernet/IP	BACnet/IP	HART
 PACs & Expansion Module Series	 Master Series	 Master Series	 Gateway Series	 Converter Series	 Converter Series	 Converter Series	 Remote I/O Module Series	 Remote I/O Module Series	 Remote I/O Module Series	 Gateway Series
 CAN	 DeviceNet	 CANopen	 J1939	 M-Bus	 PROFIBUS	 PROFINET	 EtherCAT	 Ethernet/IP	 BACnet	 HART COMMUNICATION PROTOCOL
 I-7530A-MR Gateway Series	 GW-7243D Gateway Series	 GW-7243D Gateway Series	 GW-7238D Gateway Series	 I-7590 Converter Series	 GW-7553 Gateway Series	 GW-7662 Gateway Series	 ECAT-2045 Remote I/O Module Series	 GW-7472 Gateway Series	 GW-5492 Gateway Series	 I-7547 Converter Series
 I-7565 converter series	 Remote I/O Unit Series	 Remote I/O Unit Series		 Remote I/O Module Series	 Remote I/O Module Series	 Remote I/O Module Series				 Remote I/O Unit Series
 Communication Board Series										



ICP DAS CO., LTD.

TEL : +886-3-597-3366 FAX : +886-3-597-3733 e-mail : sales@icpdas.com

<http://www.icpdas.com>



# Contents

Vol. E05\_2017

1	New Generation of Power Management Solution	Kevin Ho
5	OPC UA: New Generation Technology of the Standard Industrial Communication	Cony Yu
9	WISE-5231 Intelligent Multifunction IoT I/O Concentrator	Rick Lee
15	Residential/Commercial Building Leakage Monitoring Application	Phileo Lin
17	Lighting and Air Conditioning Management System in Hospital	Austin Lin
19	PAC in Railway Signaling Application	Cony Yu
22	ZigBee Application - Emergency Bell Alarm System	YY Chang
25	ZigBee Application - Route Management System for AGV	YY Chang



## ICP DAS CO.LTD

No. 111, Guangfu N. Rd., Hukou Township, Hsinchu County 30351, Taiwan, R.O.C.

TEL: +886-3-597-3366 FAX: +886-3-597-3733

Website: <http://http://www.icpdas.com/>

E-mail: [info@icpdas.com](mailto:info@icpdas.com)

For changes of address or subscription problems, contact us at [info@icpdas.com](mailto:info@icpdas.com)

Copyright © ICP DAS CO., LTD. All Rights Reserved. All rights reserved. No part of this magazine may be republished, reprinted or redistributed in any forms, including electronic, without written consent from the publisher.

# New Generation of Power Management Solution

By Kevin Ho

ICP DAS provides total solution products for the second phase (measurement and analysis): providing products from power meter for measurement to power meter concentrator for data logging and report analysis. The solution is comprehensive and easy-to-use, it can save time and cost in system planning and implementation; it is flexible that the user can freely add or remove the power meters according to the measurement scale. The following is the architecture provided by ICP DAS solution. ICP DAS Power management solution is DIY feasible; it is flexible and helps to quickly introduce power measurement and analysis system to the end-users with easy-to-modify operations, reasonable price and low manpower demand.

## ★ Introduction:

To implement an energy saving project, it is recommended to implement the project step by step. A general energy-saving project usually is divided into the following stages:

- Phase I: On-site investigation and inquiry  
Initiate an energy saving profile and investigate potential energy saving opportunities.
- Phase II: Measurement and analysis  
In this stage, the power measurement system should get involved to collect related data for setting up energy saving baseline.
- Phase III: Planning and negotiation
- Phase IV: Implementation and improvement
- Phase V: Energy saving performance validation

To implement energy saving project in a company, usually the general department or factory facility management department will take charge of the related issues. In general situations, they are more familiar with hardware, sometimes the manufacturer can help to install the hardware as well. However; for software implementation, usually the IT department will need to get involved or require a system integration company to assist with program development. The process will be quite complicated and the cost will be high.

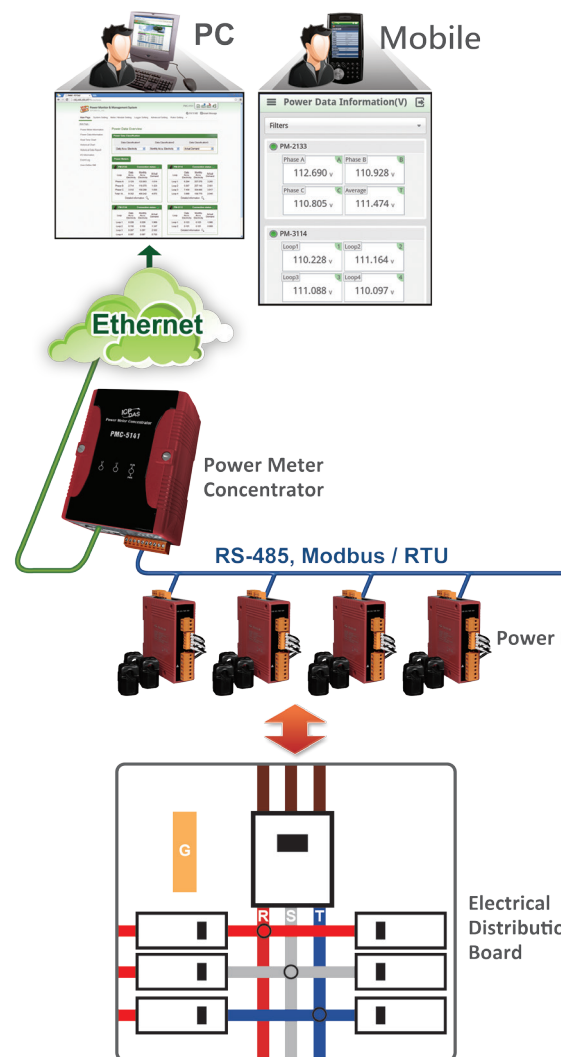



## ★ ICP DAS Solution:

ICP DAS provides total solution products for the second phase (measurement and analysis): providing products from power meter for measurement to power meter concentrator for data logging and report analysis. The solution is comprehensive and easy-to-use, it can save time and cost in system planning and implementation; it is flexible that the user can freely add or remove the power meters according to the measurement scale. The following is the architecture provided by ICP DAS solution.

## ★ Saving Cost:

### Ethernet / RS-485 converter: not required, the cost can be saved

MV146-MCM is a Modbus/RTU to Modbus/TCP converter that allows SCADA software to access the data on the power meter via Ethernet. Using the PMC-5151(ICP DAS Power Meter Concentrator), it provides connection via Ethernet, the MV146-MCM is no more required and the cost can be saved.

### Cut out the panel board: not required, the cost can be saved

ICP DAS Power Meter features standard DIN rail installation, comparing to general panel power meter, it does not require to cut out the panel board for installation.

### Software & Trials: the PC and SCADA software can be replaced by the power meter concentrator to save cost and time

To implement the software part in an application by using the SCADA software, the cost usually not only includes the software license fee and the project development cost; the cost of a PC to perform the SCADA software is also required. In addition, it always takes long time to communicate with the end users regarding requirements of all kinds of functionalities and reports.

ICP DAS PMC-5151 power meter concentrator is specially designed for electricity measurement. The well-through designed software functions includes: real-time/historical data log/ display/inquiry functions. It can generate all kinds of analysis reports. In addition, with a few clips on webpage, all software settings can be done via PC, mobile phone or tablet through remote operations, the whole process only takes about 10 minutes.



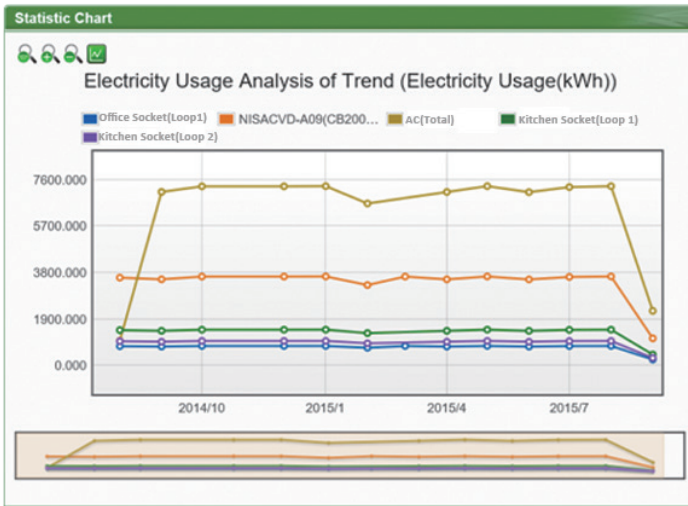

▲ Real-time/Historical Electricity Usage Trend for All Devices

## For increasing power meters: easy to add devices and expand scale

The software design for PMC-5151 is based on web-based operations. It is easy to modify the setting when increasing or decreasing the power meters connected to the PMC-5151. When it requires to expand the scale, it only needs a qualified technician to install the power meter, the software parts can be easily taken care of by the users themselves. If use the SCADA software, unless there is a well-through plan to include the adding/deleting power meter function in the system at the very beginning; the system integrators usually charge additional fee to modify the software when require expanding the scale.

## ★ Conclusion:

ICP DAS Power management solution is DIY feasible; it is flexible and helps to quickly introduce power measurement and analysis system to the end-users with easy-to-modify operations, reasonable price and low manpower demand.

## 📁 Ordering Information

PMC-5151-EN	The Power Meter Concentrator supports at most 24 ICP DAS Modbus Power Meters
PM-3033/PM-3133 Series	Three phase Power Meter for 1 circuit
PM-3112/PM-3114Series	Single phase circuits Power Meter for 2/4 circuits
PM-4324 Series	Multi-Channel Power Meter for 8 three phase circuits or 24 single phase circuits

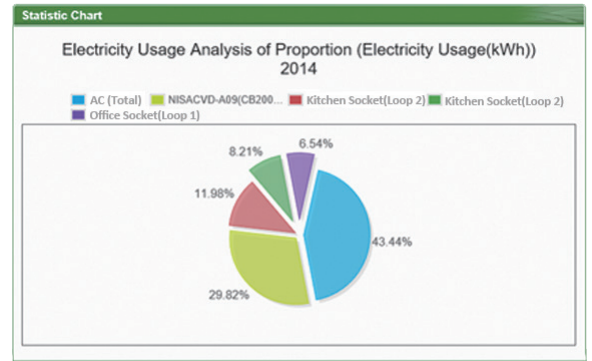

▲ Electricity Usages for Each Device

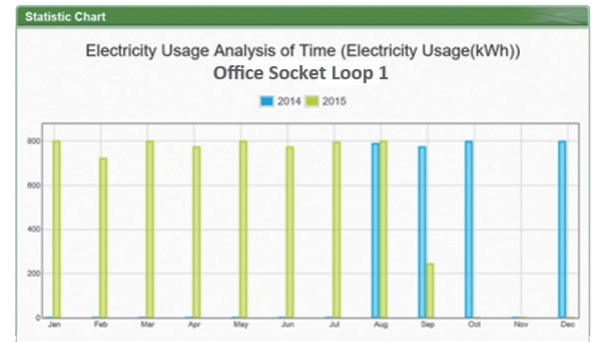

▲ Historical Electricity Usage Trend of Specific Device



# Energy Management Solutions



**Power Management**



**Logic Control**



**Data Redundancy**

- ▶ Rapidly construct energy management systems without extra software tools.
- ▶ Built-in IF-THEN-ELSE logic Engine, Include: Timer, Schedule, SSL Email sending, power demand, alarm notification...etc.
- ▶ Display real-time or historical power data trends and statistics reports.
- ▶ Support Modbus TCP/RTU, SNMP V2c, SNMP Trap protocol.
- ▶ Support DDNS communication mechanism.
- ▶ Support data logger operation, FTP Server/Client and data recovery mechanism.
- ▶ Support ICP DAS Smart Power Meters (RS-485 & Ethernet) and remote I/O modules.
- ▶ Provide local side power meter setting and data viewing (PMD).

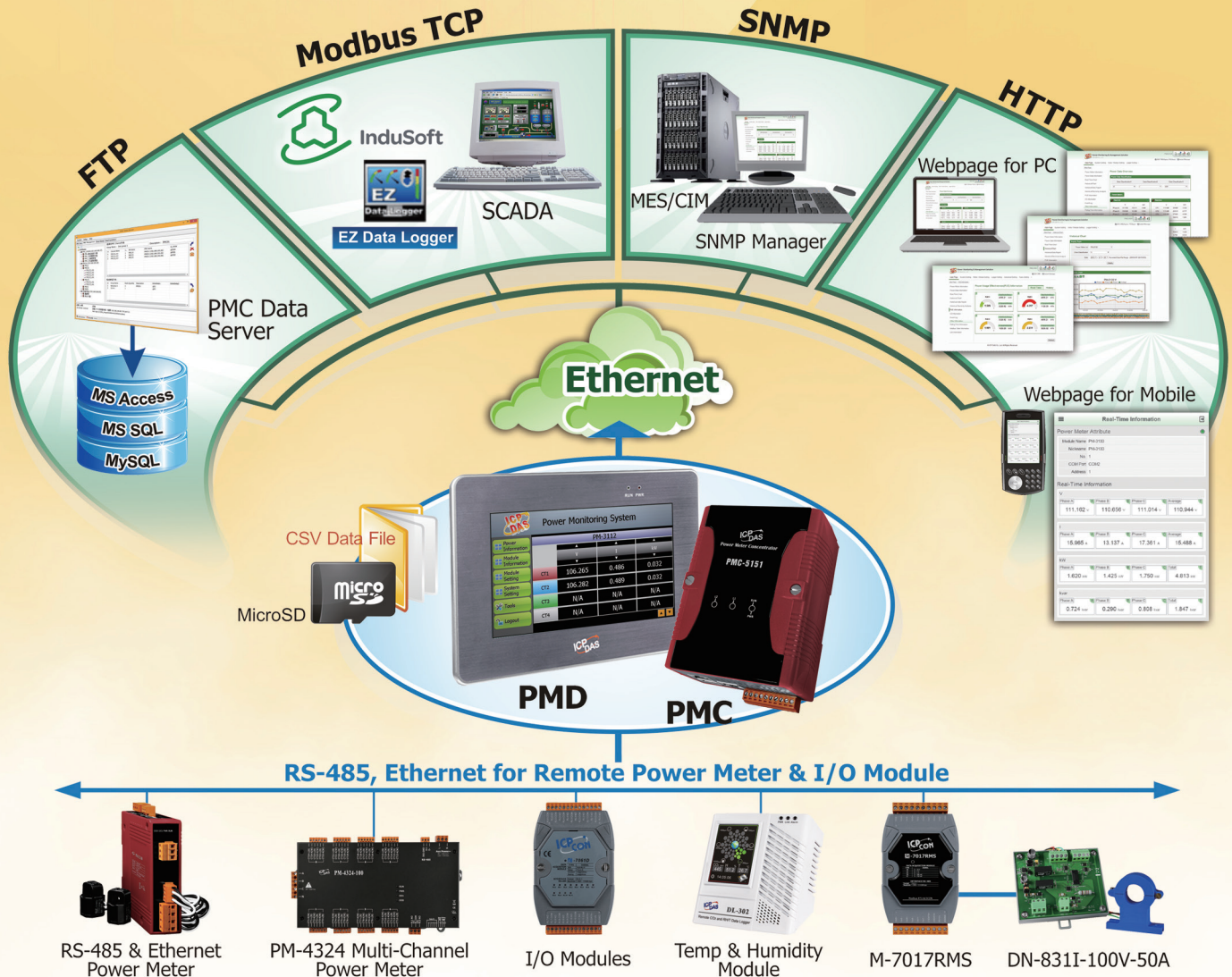

**ICP DAS CO., LTD.**

TEL : +886-3-597-3366 FAX : +886-3-597-3733 e-mail : sales@icpdas.com

[www.icpdas.com](http://www.icpdas.com)



## OPC UA: New Generation Technology of the Standard Industrial Communication

By Cony Yu

The OPC Unified Architecture (OPC UA), released in 2008, is a standard technology of industrial automation communication. It is a platform that integrates all technology standards such as OPC DA, HA, AE, and etc. It features real-time data reading & writing, historical data accessing, event/warning publishing functions.

By using reliable cross-platform architecture, the OPC UA is no longer need to rely on Windows platform as OPC DA used to be. The OPC products now can be deployed in different environments, such as: on the micro-controller or in the IT engine room. It completes the communication and interoperability between OPC data and events. In addition, for security reason, it also provides user account and authority validation between the Server and Client to protect the privacy of the service and security of the message transmission.

### The advantage of using OPC UA technology

OPC is designed to play an intermediary role between the automation hardware providers and software developers. By standard OPC interface, the devices and the software can communicate with each other so that the service providers can focus on their specialties without worrying the issues for the communication protocol between the hardware and the software when performing the data transmission. The latest OPC UA technology provides the following features that provide more options to the users.

1. Guarantee seamless integration with the conventional OPC service products  
The data model of UA can be compatible with the conventional OPC. By using “Wrapper”, the UA program can be packaged in Microsoft COM technology. Therefore, the early users do not need to upgrade the conventional OPC, by using “Wrapper”, it can connect to new added OPC UA services.
2. Break the limitations of conventional OPC  
Functional equivalent: all classic specifications of COM OPC are included on the UA.  
Platform independence: can be deployed on the embedded controller or the cloud-based engine

room, etc.

Security: the encryption, authentication, and validation between the users and the services.

Scalability: add new functionality without affecting current application and program.

Full-range information modeling: can be used to define complex information modeling.

3. Reliable Design  
It ensures the arrival sequence of the data and content validation when performing message transmission so that helps the decision making for backend processing and enhances data accuracy for the data logger software. It is perfect to be applied to the industrial production or service system applications that cannot afford long idle time, by using the OPC UA redundant mode, it provides redundancy support to resume the system in real time or in short time.
4. Collaborative technology foundations  
OPC Foundation works with various technology foundations to incorporate data models of different kinds of technology into the OPC UA; so that it can achieve interoperability in technology and improve applications in industrial automation,

production process, ERP, sales enterprise, building automation, security and smart grid industry, etc. For example, the foundations related to field devices such as: the FDT Group, Fieldbus Foundation, HART Communication Foundation, PROFIBUS & PROFINET International, and the foundations related to building automation such as: BACnet Interest Group and ISA95 of the International Automation Association, etc.

## ICP DAS OPC UA Solution

UA-5231 is the first data acquisition controller developed by ICP DAS which can be integrated with OPC UA Server, MQTT services and other data communication protocols. With the advantages of the RISC-based CPU architecture, compact size and low power consumption; UA- 5231 can be applied to a variety of field environments. Applying OPC UA allows integration the I/O products of ICP DAS with the third-party devices, and then import the data information to the backend SCADA, cloud or other decision making or data logging system. It satisfies the reliability, interoperability and security needs of the industrial automation system and meets the trend of the smart internet.

## UA-5231 Hardware Features

- OPC UA Server and MQTT Client Service
- MQTT Broker Inside
- AM3354, 1 GHz
- 256 MB RAM and 512 MB Flash
- Linux kernel 3.2.14 OS
- Real-Time Capability
- 64-bit Hardware Serial Number for Software Protection
- Support Redundancy and PID
- 10/100/1000 Mbit/s Ethernet Port
- 4 Serial Ports (RS-232/RS-485)
- Wide Operating Temperature Range: -25 to +75 ° C



## UA-5231 Software Features

With the Web-based User Interface, the users can log in and configure the controller via a web browser on a mobile device or PC.

The IEC 62541 standard OPC UA Server is certified by OPC UA Server OPC Foundation, it helps to integrate the on-site devices to actively upload the data to the application systems without worrying the problem of crossing the platforms.

Implement the Redundancy of OPC UA Server. With the ICP DAS OPC UA Client product, it can provide the redundancy function of the Server to enhance the reliability of the system.

The PID function can combine the remote I/O devices to simulate the PID control system for computing control solutions required on-site.

The Modbus TCP/RTU Master module can connect to all-kinds of standard Modbus TCP/RTU Slave devices via the RS-485, RS-232 or Ethernet ports on the controller. Therefore it is able to provide scalability and flexibility when building a system and meet various requirements for all kinds of applications.

The MQTT Broker is compliance with MQTT v3.1.1 protocol. It supports MQTT message distribution management. The users do not need to build Broker system when using MQTT communications.

With the MQTT communication function, it allows communication between the IoT devices and the OPC UA system. The UA-5231 then conducts the data acquisition and management function; at the same time, the data of the devices managed by UA-5231 can also be converted and published to the IoT system.

## Application Architecture:

- Modbus I/O convert to OPC UA

**(Modbus ↔ OPC UA)**

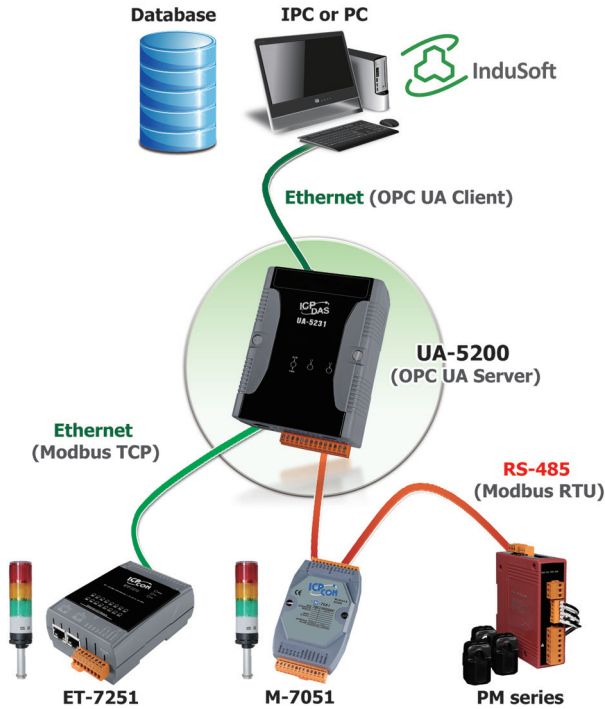

- MQTT convert to/from MQTT

**(Modbus ↔ MQTT)**

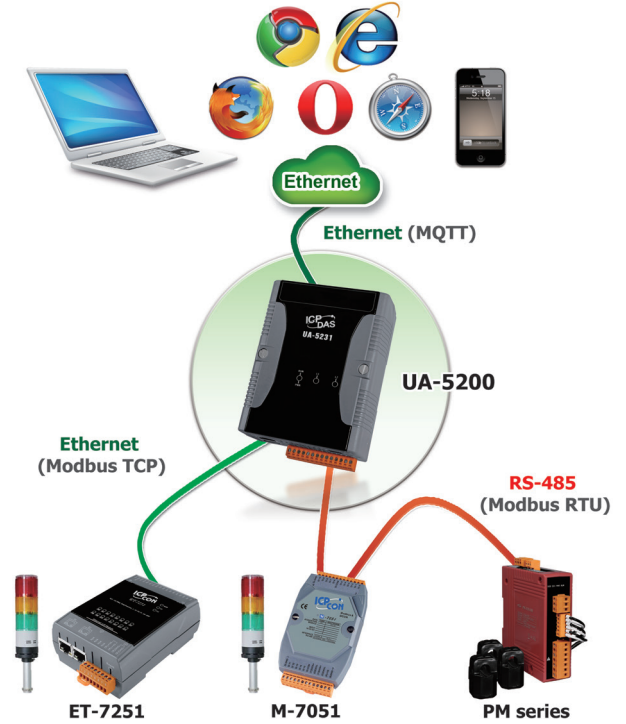

- Modbus I/O convert to OPC UA

**(Modbus ↔ MQTT)**

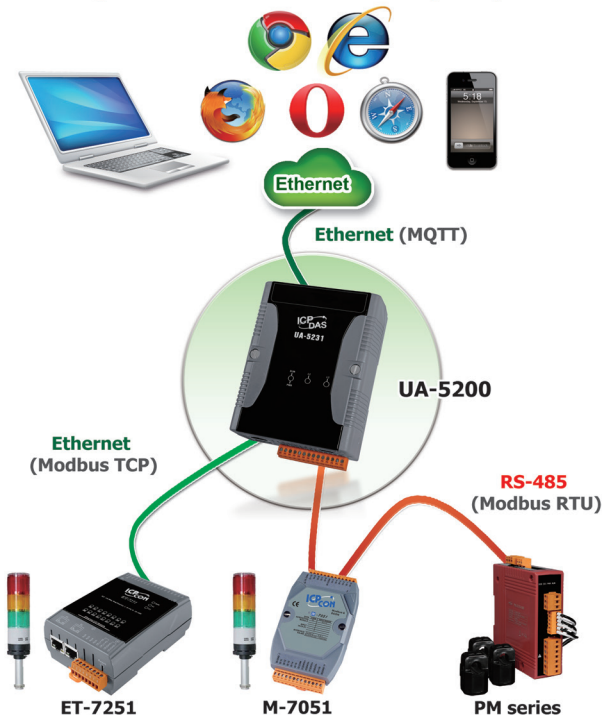

- MQTT convert to upper OPC UA Client

**(MQTT ↔ MQTT)**





## Summary

With the arrival of Industry 4.0 era, a smart factory is required to feature real-time response and automated production. ICP DAS UA-5231 can help to fulfill integration of all kinds of physical or virtualized functionalities. UA-5231 is a versatile intermediary control system; for its lower ends, it can integrate sensors, on-site devices and IoT applications, and for its upper ends, it can integrate project management, manufacturing and other management applications.

By using UA-5231, the factories and enterprises can fulfill:

1. Web-based vertical integration of upstream and downstream system.
2. The on-site data can be integrated at the back end system for further analysis.
3. Horizontally connect each subsystem.

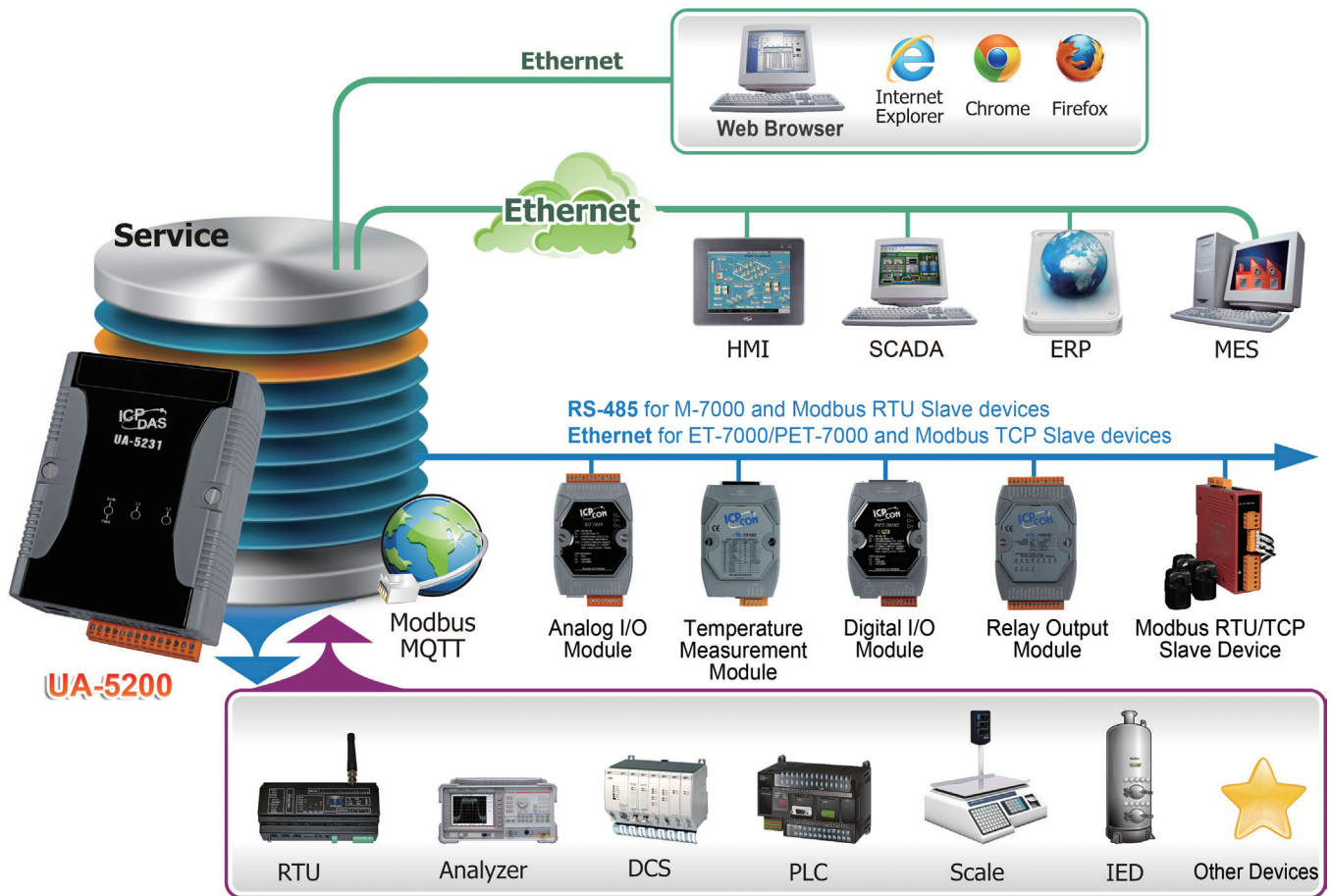

▲ System Architecture

# WISE-5231 Intelligent Multifunction IoT I/O Concentrator

By Rick Lee

Industry 4.0 is based on IoT (Internet of Thing) that incorporates the technological concept of communicating and exchanging information between all facilities which brought manufacturing industry to a new era. The WISE-5231 Intelligent IoT Controller developed by ICP DAS is a perfect start point to facilitate the vision of the Industry 4.0 era.

WISE-5231 provides powerful and flexible integration with the I/O modules and sensors at the field side, and also supports various IoT protocols for seamless integration with the SCADA/MES/MIS/IT/IoT Management systems to transfer the real-time I/O information from the front-end modules (or sensors) to the back-end management systems. It also features reliable real-time I/O logic control and data logger operations. All of these features make WISE-5231 a perfect concentrator of sensor and I/O modules in the IoT age.

## Introduction

WISE(Web Inside, Smart Engine) is a product series developed by ICP DAS that functions as control units for use in remote logic control and monitoring in various industrial applications. WISE offers a user-friendly and intuitive web site interface that allows users to implement IF-THEN-ELSE control logic on

controllers just a few clicks away; no programming is required. With its powerful and easy-to-use features, it will minimize the learning curve, shorten time to market and dramatically reduce the labor and cost spent on system development.

WISE-5231 provides more supports in I/O functions. It allows connections to XV-board; supports

WISE-5231 System Architecture

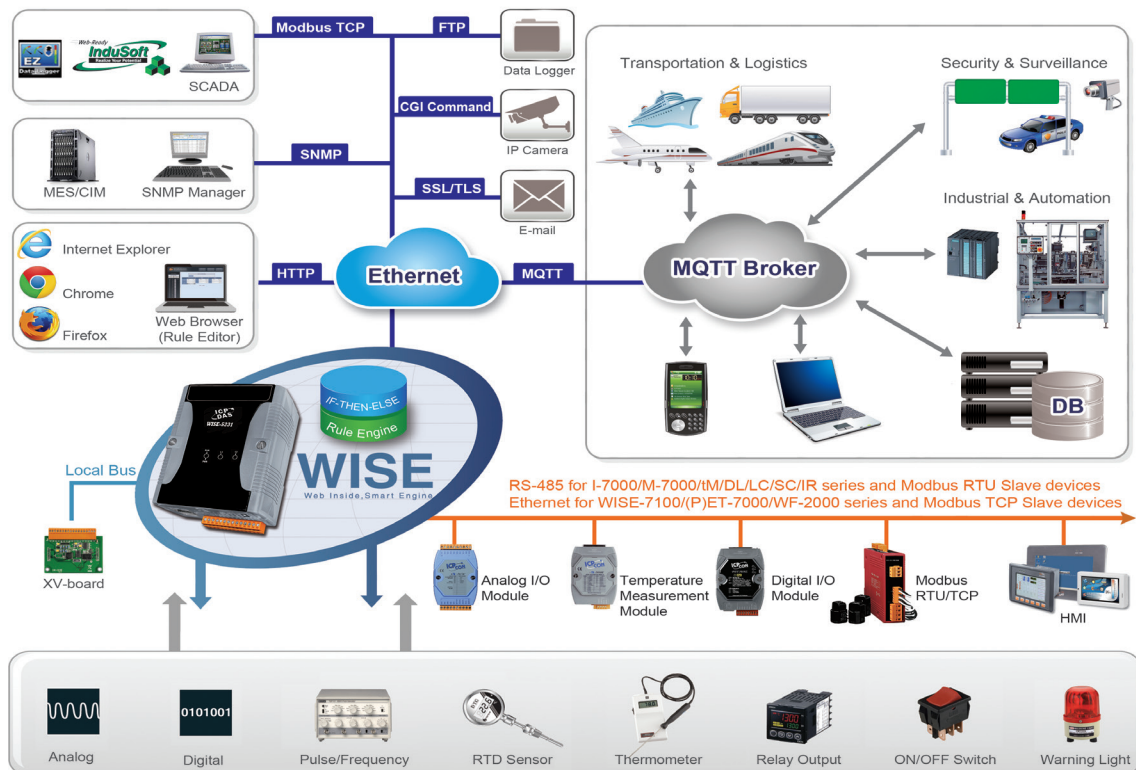

DCON I/O modules, Modbus RTU Slave modules and Modbus TCP Slave modules together. The wide range of selection options enables flexibility in I/O module integration to meet the requirements from various applications. WISE-5231 provides Data Logger function to record the I/O channel data by periodic cycle or event trigger. And it allows to send the data files by FTP to the control center. In addition to the CGI command sending function, WISE-5231 now supports the CGI command receiving function that allows the devices (such as IP camera) connected to the network to trigger the operation of IF-THEN-ELSE logic rule of WISE- 5231. The well thought-out CGI command functions make WISE-5231 being able to interact with the devices flexibly in the network

environment. WISE-5231 also supports SNMP, SNMP Trap, MQTT and DDNS protocols and services. The flexible integration ability with the SCADA and IT software or devices and the reliable ability of real-time I/O logic control and data logger make WISE-5231 the most cost-effective I/O controller in the IoT (Internet of Things) Age. ◦

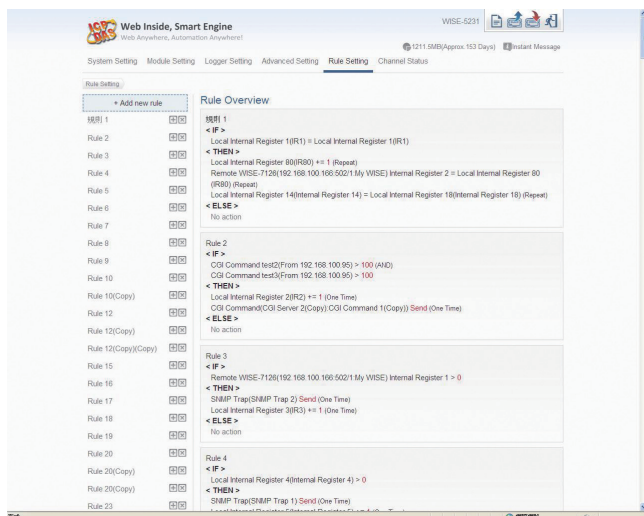
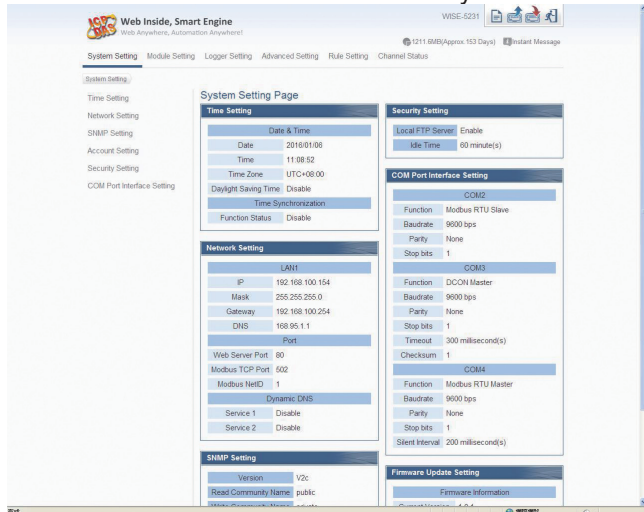
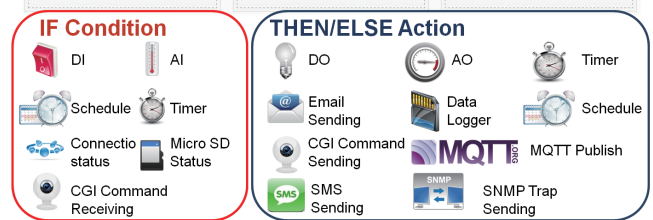

## Features

Simple, easy-to-use, no-programming-required for system development



WISE provides user-friendly Web UI pages for editing control logic on the controllers. To edit control

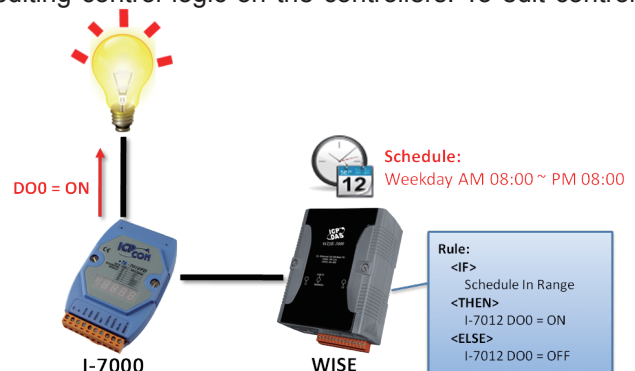



logic, it only requires a browser to connect to the Web server on WISE. No extra software tool installation is needed. WISE enables implementation of logic edition by a few clicks on the mouse to set up and deploy logic rules without writing a single line of code.

## IF-THEN-ELSE logic rules execution ability

WISE controller features an IF-THEN-ELSE logic rule engine; it offers IF-THEN-ELSE rules for users to set up the logic content. After completing rule edition and downloading rules to the WISE, the rule engine will loop execute the rules in accordance with the execution order under specific conditions.



## Connection ability to a variety of sensors and devices

WISE Controller allows to connect with sensors and devices that support Modbus TCP/RTU protocol for I/O monitoring. The ability to connect with Modbus

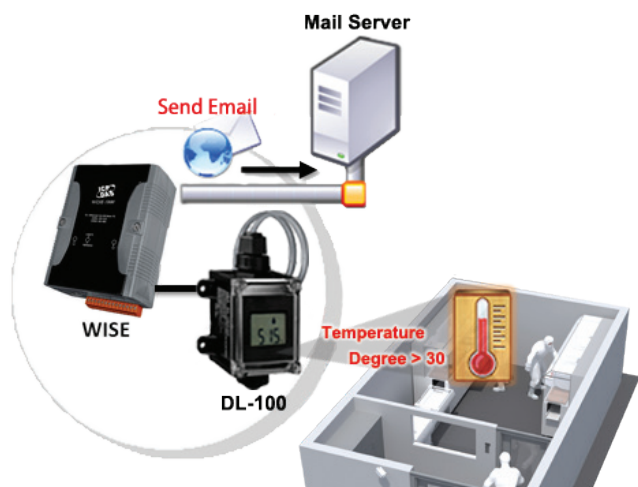

TCP/RTU slave devices enables the flexibility and scalability for system implementation and allows to meet various requirements of the applications from the clients.

## Provide Timer and Schedule operation

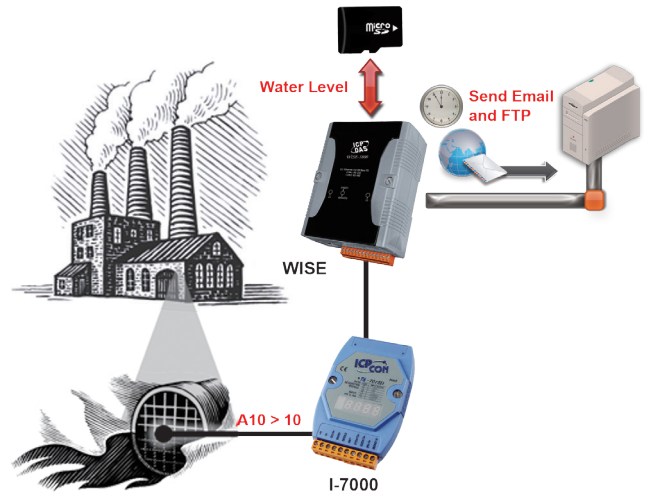

WISE features Timer and Schedule functions: It allows user to schedule specific date or time for control logic execution, or perform specific tasks such as time delay. With calendar user interface provided, Schedule setting can be more efficient and flexible.

## CGI Command sending & receiving for surveillance system integration

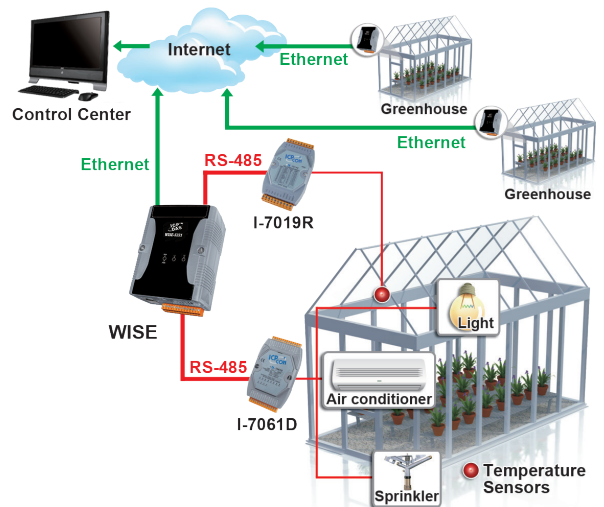

WISE supports full CGI command operations - CGI command sending and CGI command receiving. The CGI command sending action can be added to the logic edition as part of logic control in response to specific events. The CGI command receiving function enables WISE to receive the CGI commands from other network devices. The content of CGI command received can be used in IF condition statements to trigger the THEN/ELSE actions.

## Real-time alarm notification via SSL Email

WISE supports SSL Email sending function for real-time message notification operation. The message sending action can be added to the logic edition as part of logic control to provide real-time

message notification to the related personnel when an event occurs.

## Data Logger operation

With the microSD card, WISE provides Data Logger function to real-time record the I/O channel data of the controller and sends the data files automatically by FTP to the control center for further administration management or data analysis.

## Active I/O sending mechanism

In addition to the Modbus TCP/RTU slave function that enables SCADA system to poll the I/O channel data of the WISE, now WISE provides “Active I/O sending” mechanism (Modbus TCP master, SNMP Trap and MQTT publish). Based on

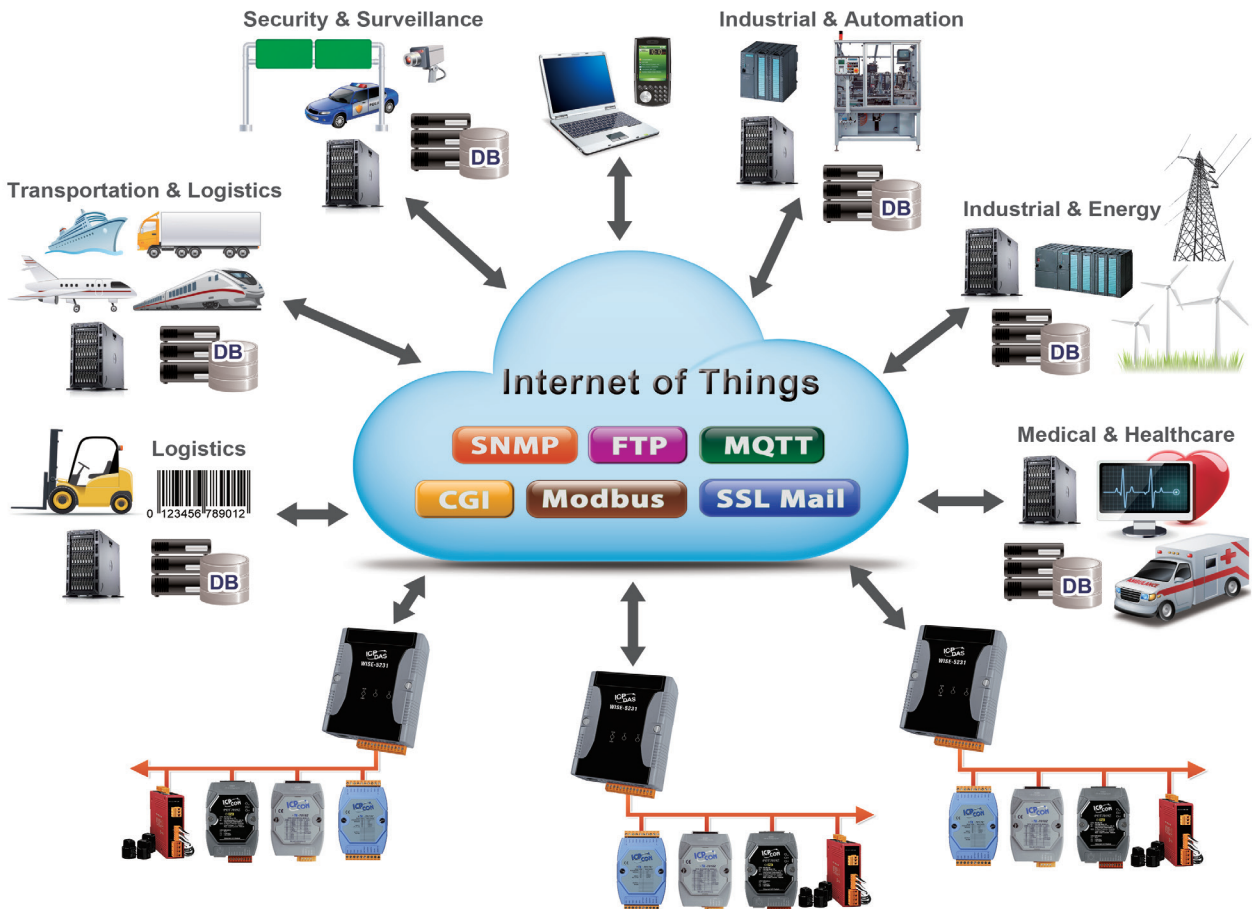

the “Active I/O sending” , WISE allows to send the I/O channel data of the controller actively to SCADA/IT system by event trigger (change of the I/O channel data) or periodic cycle. This function will improve the efficiency of the data communication between WISE and SCADA/IT system. ◦

## A variety of protocols supported for integration with SCADA/IT/IoT System

WISE supports various communication protocols to perform real-time monitoring and control of the controllers. The Modbus TCP/RTU protocol of WISE allows sharing I/O channel and system data with the SCADA system. WISE also support the SNMP, CGI, FTP and MQTT protocols for easy integration with the IT/MIS/MES/Facility management /Network management system. The flexible integration ability with the SCADA and IT system make WISE the most cost-effective I/O controller in the IoT (Internet of Things) applications

- Support Modbus TCP / RTU industrial protocol
- Support SNMP (Simple Network Management Protocol) network management protocol
- Support MQTT (MQ Telemetry Transport) protocol, to achieve the data linked to the concept of networking industries
- Support FTP Server / Client mechanisms to provide two-way data log file maintenance operations
- Support SSL / TLS Email, instant notification live state
- Support CGI (Common Gateway Interface) commands to send and receive, with network equipment (such as: IP Camera) complete interaction
- Support DDNS dynamic domain name system

## Application

- Building Automation
- Factory Automation
- Machine Automation
- Facility Management
- Facility Management
- Environment Monitoring

WISE-5231 features easy-to-use, reliable and multi-functions. It is designed to provide cost-effective software and hardware solutions to meet various requirements from the users and significantly reduce the time and labor spent in the process of system developments. For more information about WISE-5231 please visit:

WISE-5231 product catalogue : <http://wise.icpdas.com/downloads/datasheet/WISE-52xx-EN.pdf>

WISE-5231 Website: <http://wise.icpdas.com/news/WISE-5231/>

ICP DAS Website : <http://www.icpdas.com>



## Software Specifications

Function		Description
User-friendly and intuitive web site interface	Browser	Runs on browsers, no extra software tool is required No more programming, Web pages provided for control logic editing and system parameters setting
Various options for easy I/O module integration	Local side	Support XV-board
	Remote side	Support DCON or Modbus RTU Slave devices (Up to 32) Support Modbus TCP Slave devices (Up to 16)
Intelligent Logic operation and data logger ability at field sites	IF-THEN-ELSE Logic operation	Provide IF-THEN-ELSE logic rule editing, and the ability for IF-THEN-ELSE logic rules execution
	I/O channel monitoring and control	Offers various options for I/O channel settings; for example: deadband setting for AI signals, linear scale setting, temperature degree in Celsius or Fahrenheit setting, power on value setting for DO channel, pulse output setting and DI counter setting, etc
	Timer	Perform the timing function. The status of Timer can be included in IF condition statements to trigger the THEN/ELSE actions
	Schedule	Perform the prescheduled routine tasks. The status of Schedule can be included in IF condition statements to trigger the THEN/ELSE actions. "Calendar" and "Weekly repeat" schedule setting UI are provided.
	Email	Execute Email message sending. The SSL/TLS authentication is provided
	CGI Command	Perform CGI command sending and receiving functions. The content of CGI command receiving can be used in IF condition statements to trigger the THEN/ELSE actions
	Data Logger	Perform Data Logger function to real-time record the I/O channel data of the controller by Period or Event Trigger operation
Various protocols for seamless integration with SCADA/MIS/MES/IT/Network Management systems	Real-Time I/O channel data	Support Modbus TCP/RTU protocol for SCADA system Support SNMP and MQTT protocols for the integration with MIS/MES/IT/Network Management systems CGI Command sending and receiving function supported for the integration with IP Camera and Network devices. Active I/O sending mechanism supported
	Historical I/O channel data files	FTP Server/Client ability for the maintenance of data logger files and the data logger files automatically send back operation Provide data recovery mechanism so that when experiences network disconnection, the data log files will be kept in WISE, and be recovered after the network is resumed Provide alarm notification mechanism so that when microSD card is damaged, the data log file will be stored in WISE to ensure zero data loss of the data logger
	Communication Service	DDNS (Dynamic DNS) service supported

# Residential/Commercial Building Leakage Monitoring Application

By Phileo Lin

The applications in residential/commercial building leakage monitoring has become increasingly widespread. For example, large-scale monitoring system such as: water storage system, daily water purification system, wastewater discharge pipe system, fire fighting water systems, and small area monitoring system such as: kitchen sink, bathroom, water tower, senior home care, etc.. By applying the architecture of the internet of things, it allows to transmit the data to the cloud in real-time for monitoring and control via wired or wireless transmission. In this way, it provides solution to save water effectively, improve the safety or living household and avoid problems caused by water leakage.

## Introduction:

ICP DAS provides both wired and wireless leakage monitoring solutions. Wired solution uses

M-7026 with 3M S-1F Sensor Cable; each M-7026 can connect up to 6 S-1F Sensor Cable to monitor 6 spots. The monitoring data can be sent back to the control center via the built-in Modbus protocol in M-7026. The wireless solution uses ZT-2026 and 3M S-1F Sensor Cable. Each ZT-2026 can connect to up to 4 S-1F Sensor Cable to monitor 4 spots. The monitoring result can be sent to the control center via

the built-in ZigBee protocol in the ZT-2026.

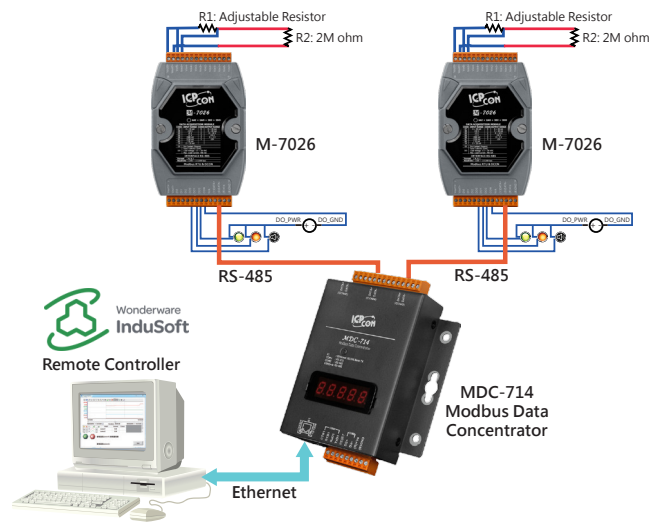

▲ Wired Monitoring System

## Household Leakage Monitoring:

For water leaks inside the household, the indoor stagnant water easy to occur in areas like kitchen sink, discharge pipe system of the washing machine and water tower. The water leakage system can be installed in these areas for real-time monitoring and if there is water leakage occurs; all unnecessary sources of stagnant water can be emptied immediately.

## Senior Home Care

The residential security for the seniors is getting more and more important as our society is aging. The senior may fall into the bathtub and get drown due

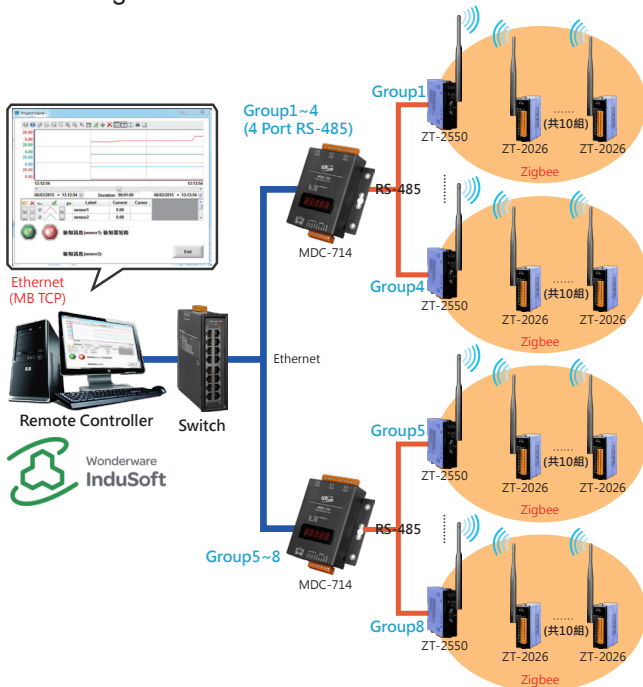

▲ Wireless Monitoring System

to falling or heart attack. Therefore we can monitor the water level of the bathtub by using the Leakage Monitoring system, and once there is an unusual event occurs, the immediately response can be taken in real time.

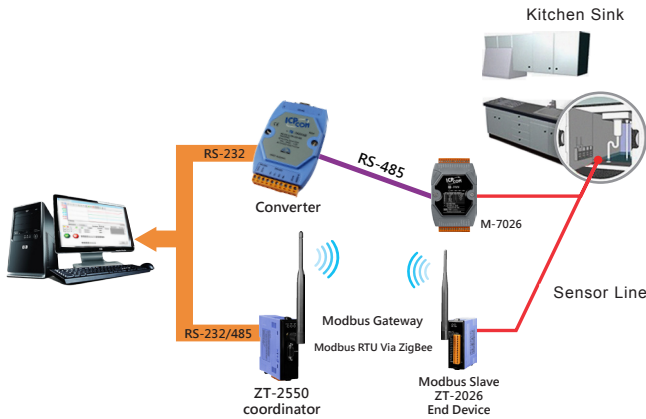

▲ Kitchen Sink Monitoring

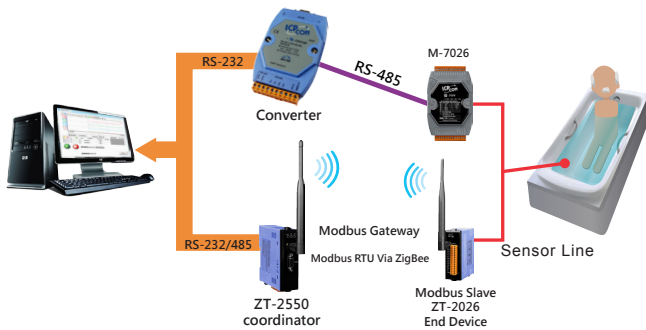

▲ Senior Home Care

## Building Leakage Monitoring:

The water system in the building usually includes the following system: daily water storage system, drinking water purification system, drainage system, fire fighting water system and Heating, Ventilation and Air Conditioning system, etc.

With the SCADA software InduSoft, it can quickly establish a monitoring systems and set up the trigger conditions to trigger the DO on the M-7045 module and then turn on the alarm and warning lights, and inform the related personnel for immediate response when an event occurs.



▲ Water System of the Building

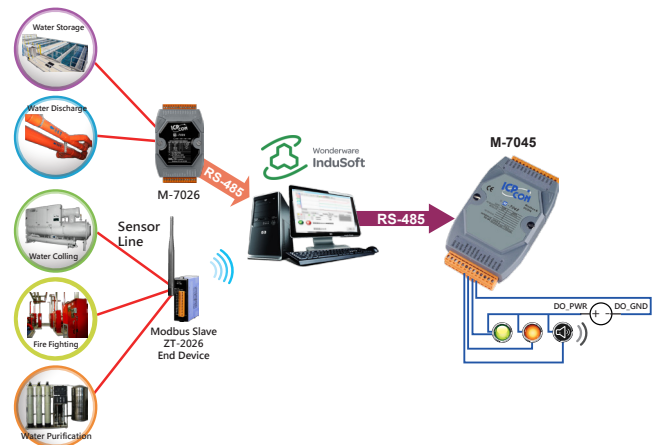

▲ Building Water Leakage Monitoring System

## Summary:

ICP DAS provides both wired and wireless leakage monitoring solutions. The customer can freely choose the most appropriate leakage monitoring solution for their specific application to achieve saving the water resource and enhance the home/building water consumption safety. In the future, ICP DAS will continue to bring more value to our customers by developing cost-efficient solutions in the field of environmental monitoring.



# Lighting and Air Conditioning Management System in Hospital

By Austin Lin

ICP DAS TouchPAD features all in one functions such as: quick deployment, rapid integration, easy maintenance and display. It cut the cost of PLC and HMI yet provides similar or even more convenient features. By using ICP DAS TouchPAD (TPD) to control the devices and function as communication interface; TPD can work as a controller equipped with display function which add more values and upgrade the competitiveness in project implementation.

SC-4104-W1 module provides three types of built-in control logic: each type provides three interlocking control functions. The user can freely switch in functions to quickly build and design most appropriate applications.

## Introduction

In most temperature control applications, usually it uses one master control panel to work with more than one control boxes. However the master control panel can only communicate with the control boxes connected under its architecture. Each time when adding new sensors or modules to the system for new requirement, it is required to design a new architecture. However, for TPD-283U, our driver allows to add new modules freely at any time, no matter via communication interfaces such as RS-485 serial communication device or Ethernet, which provides a friendly and easy solution to the maintenance staff.

## Description

This application is to implement lighting control system for sickrooms in a local hospital, we will transform traditional control system to smart building automation control system. The following devices are the major devices used in the applications:

### SC-4104-W1

The SC-4104-W1 is perfect to be used in Fan Coil Unit and indoor lighting control. It features built-in logic for quickly switch to different scenarios. A variety of scenarios interlocking reactions are provided for users to quickly switch to desired fan speed and lighting intensity.

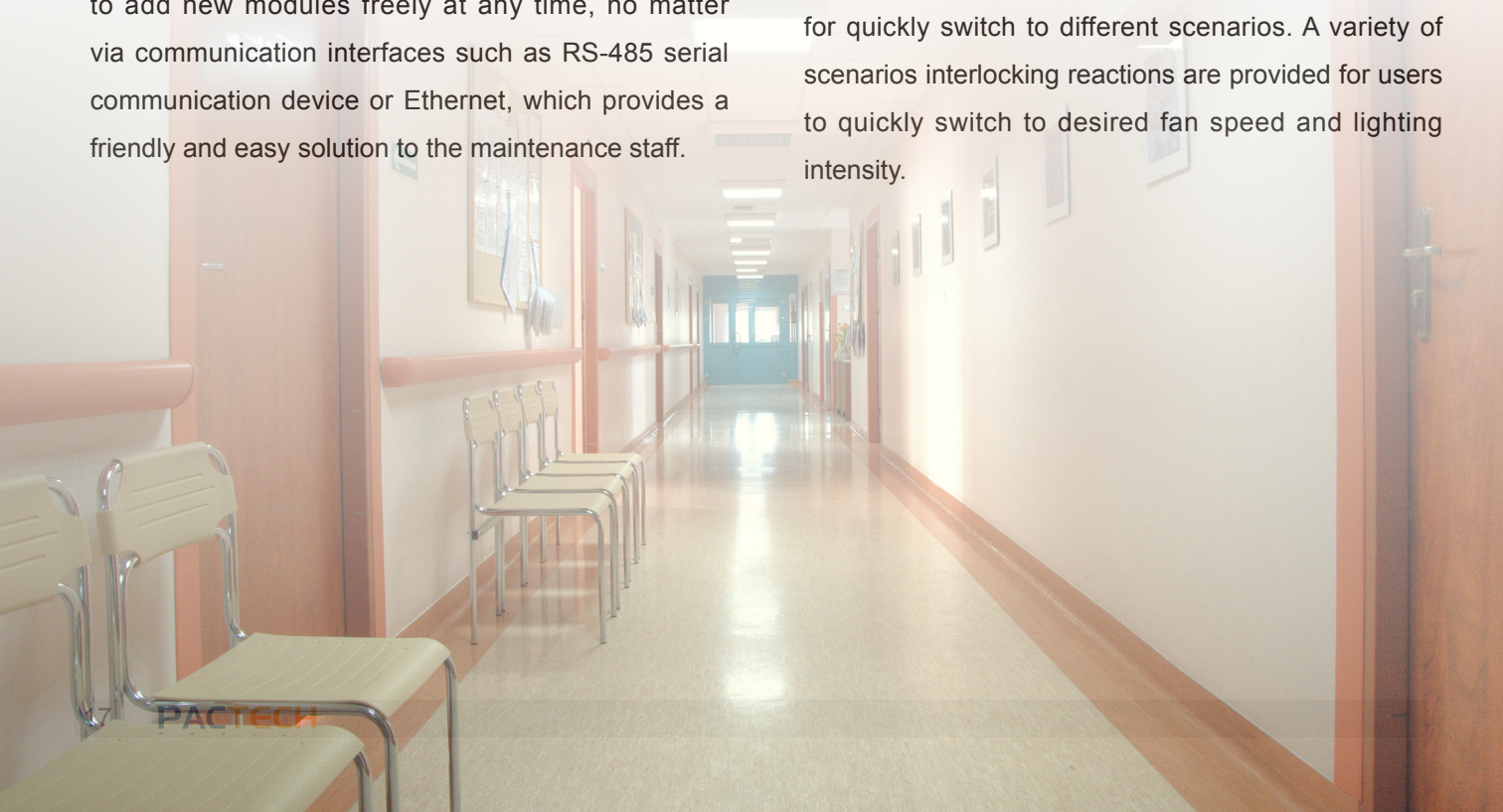

## LC-101

Used for lighting controlling in the sickrooms and walkway.

## TPD-283U

TPD-283U is 2.8 inch HMI and designed for data acquisition of the modules. And it provides seamless integration with the software(InduSoft) for central control. Unlike traditional control panel, TPD-283U features more functions as below:

1. Built-in DCON/Modbus Protocol, which allows to communicate with the devices that is equipped with the same communication protocol; not like the general control panel which can only control a few devices.
2. More flexible built-in C/ladder language, it also can work as a Gateway for different devices.
3. Features one RS-485 serial communication

interface and one Ethernet interface. In this application, it performs data acquisition from the lower modules and then transmits the data to the central monitoring software via the Ethernet.

The TPD-283U and SC-4104-W1 provide a wide range options for used in different applications, in addition to the interlocking control, more control functions are provided as below:

1. Cooling Control
2. Heating Control
3. Alarm Control

In this application, the TPD replaces the previous controller and displayer, and the SC-4104-W1 is used to replace the lighting control and Fan Coil Unit. This cost-effective and easy-to-use solution provides competitiveness in project implementation.

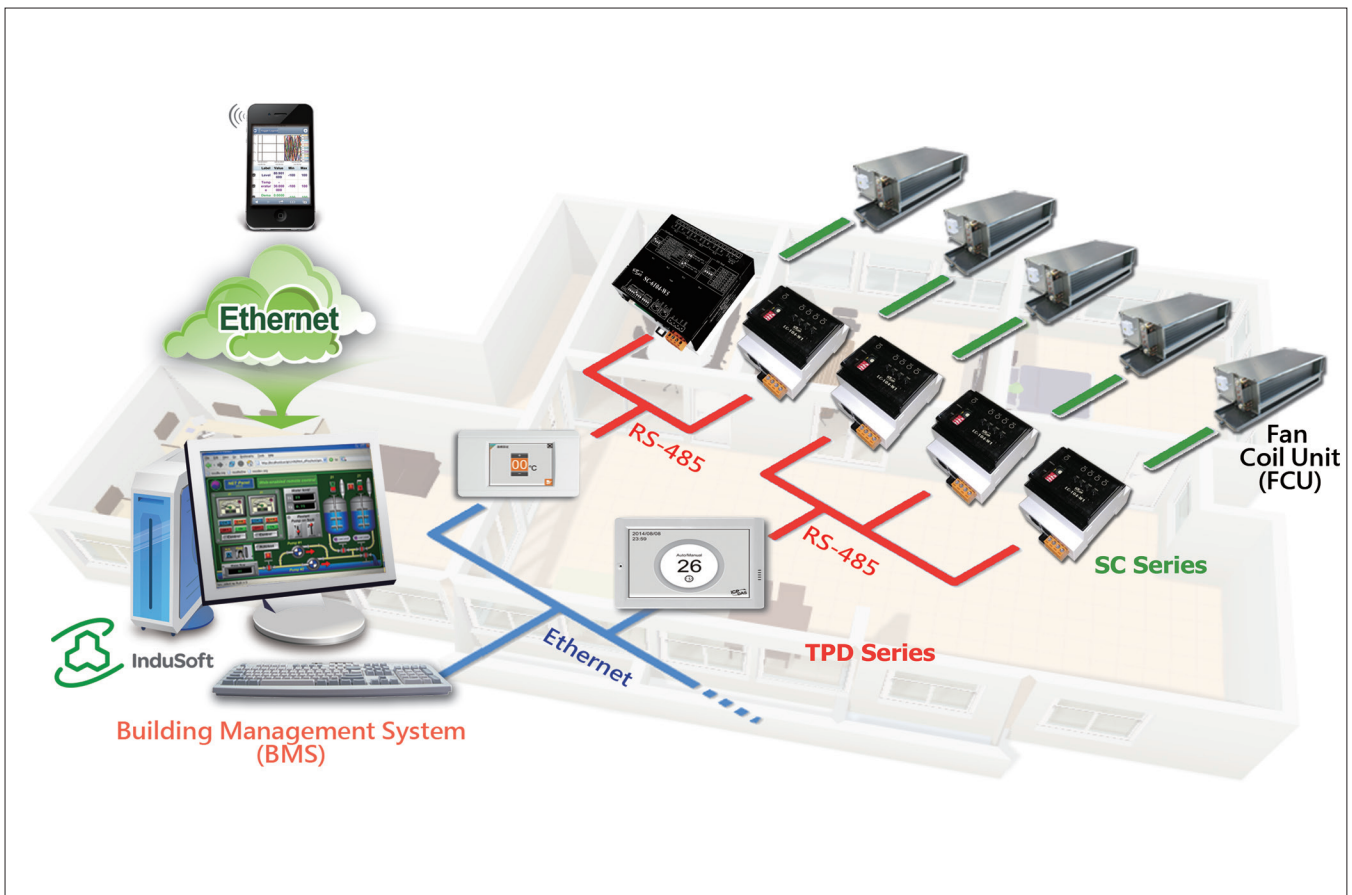

# PAC in Railway Signaling Application

By Cony Yu

The Railway Signaling system is a series of chain control system. If one device is failed; a series of back-end devices may also be failed. It caused the difficulty for the maintenance personnel to trouble shooting; they can only check step by step to verify which operation is failed based on the final failure result; the maintenance personnel is easy to be confused and hard to find the source of the trouble.

By using the railway signaling monitoring & control system, the signal can be effectively operated, and the management can be centralized and can easily analyze and track the causes of failure which makes it easy to quickly rule out or trace the problem sources so that any device failure can be detected in real time. The safety of railway operations will be enhanced, train punctuality will be improved and the maintenance work will be easier to achieve a reliable and efficient railway signaling management system.

For railway signaling, as the increasing of the high-speed train and train service frequency, and external factors such as climates and night time driving risk, the railway signaling system has become more and more important.

The purpose for railway signaling monitoring & control system is aimed to increase the reliability and efficiency of railway

signaling operations. By using network transmission and user-friendly graphic control interfaces, it is easy to perform operations of the hardware or software devices for railway signaling management, and then the information can be collected for further data analysis, furthermore, makes it easy to quickly rule out or trace the problem sources so that any device failure

can be detected in real time. The safety of railway operations will be enhanced, train punctuality will be improved and the maintenance work will be easier to achieve a reliable and efficient railway signaling management system.

## System Architecture

The railway signaling monitoring & control system includes three parts: signal converter, SCADA systems and signal processing and control unit.

## Signal Converter

The signal converter can connect to VPI, NVPI, VDU modules via RS-422 / RS-232 to receive/send the information and exchange information with the SCADA system, traffic control center or the central server. The received/sent

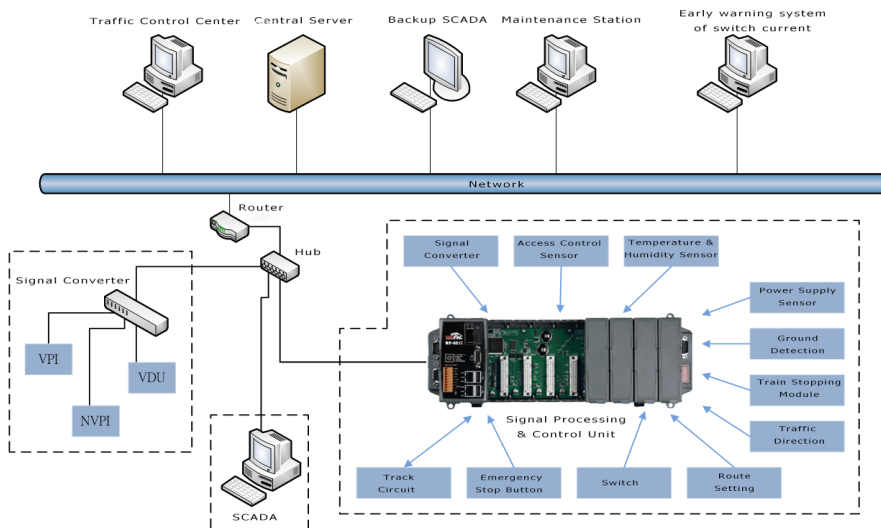

▲ System Architecture



information including the following: CTC information, VDU information, PIDS communication information, station information before (or after), receiving (or sending), etc.. The information that the SCADA system receiving before/after or sending before/ after will be decoded and then the data (or processed data) can be displayed or recorded.

## Signal processing and control unit

WinPAC-8XX7 series Programmable Automation Controller (PAC) is used for signal processing and control. It features high computing performance CPU, large-capacity memory and storage space, a wide range of input/output interfaces (such as USB, VGA, Ethernet, RS-232 , RS485, etc.), built-in real-time operating system & firmware that meet the IEC-61131-3 standard, it also provides multiple programming options such as: functional block diagram (FBD), ladder diagram (LAD), Sequential Function Chart (SFC), and Structured Text (STL), etc..

With the help of the plug-in digital or analog modules (such as I-8014W, I-87053W or I-87057W) or with RS-485 / RS-232 (such as I-8144iW), it is able to receive or send the messages. After the data is processed, it can perform data exchange with the SCADA system, traffic control center and the central server via internet. The receiving/sending messages include: AF track circuit information (communication), PF track circuit information (communication), the emergency stop button status(digital), switch information (digital, analog), the route setting information (communication), the traffic direction information (communication, digital), information for train stopping module (analog), ground detection status (digital), power supply information (digital, analog), temperature and humidity information (communication), access control status (digital), signal converters (communication) and etc..

Model		WP-8137	WP-8437	WP-8837	WP-8147	WP-8447	WP-8847
OS		Windows CE 5.0					
ISaGRAF Software	ISaGRAF Ver. 3	IEC 61131-3 standard, LD, ST, FBD, SFC, IL & FC					
	Scan Time	3 to 15 ms for general program 15 to 50 ms for complex or large program					
CPU / SDRAM		520 MHz / 128 MB					
Flash		128 MB			96 MB		
Memory Expansion		microSD socket with one microSD card (support up to 32 GB)					
RTC (Real Time Clock)		Provide second, minute, hour, date, day of week, month, year					
Dual Watchdog Timers		Yes					
VGA		Yes 640 x 480, 800 x 600, 1024 x 768			Yes 640 x 480, 800 x 600		
Ethernet		RJ-45 x 2, 10/100 Base-TX (Auto-negotiating, LED indicators)					
Slot Number		1	4	8	1	4	8
		Note: For High Profile I-8K and I-87K Modules Only					
Operating Temperature		-25 to +75 ° C					
Input Power Range		+10 to +30 VDC					
Redundant Power Inputs		Yes, with one power relay (1 A @ 24 VDC) for alarm					

▲ Main Specifications of WinPAC-8XX7

## SCADA System

The SCADA system adopts intuitive graphic control interface, the information of signal converter or the signal processing and control unit can be displayed hierarchically on pages. The main page includes: real-time data, accumulated data, and charts/data analysis. The sub-pages includes the following control interfaces: alarm management (real-time and historical data inquiry), statistics & analysis reports, parameter settings for critical values, database management, settings or modification for system operation parameters and replay of track operations. With access control mechanism, the administrators or general operators can access the control system in the control room or via remote network.

The real-time information page displays the route in diagram and shows the connection status of the stations in real time. The monitoring page shows the real-time information of each monitoring point in the station, and shows the speed code of each track circuit, working current of the track circuit and the reverse current value of the switch in the route map.

On the accumulated data page, it shows the error message log and the time chart of working current of each track circuit. The replay of track operations is also an important function to be displayed. When the track operation is abnormal, after performing troubleshooting operations, the replay of track operations can be used to verify the source problem that result in abnormal operations, and then improve the system or clarify the responsibility in relation accordingly.

The replay function of Track operation is designed to monitoring the system. It can be replayed

at 0.5 or 2 times speed which makes it more efficient when retrieval of a specific event is required.

The data analysis chart page can be used to perform warning analysis to avoid failure occurring. The following figure shows an example of switch motor of railroad switch; the switch drive motor includes forward and reverse modes. The warning analysis can be done by comparing the motor data provided by the manufacture before the installation (including the voltage, current and power graph of the forward/ reverse motor) with the real detected data measured after installing the railroad switch. Based on thread hold criteria provided by the customer (including the time to start the railroad switch till reach the fixed position and the peak measure value after starting the switch.) When the criteria of the thread hold is exceeded; it will send out warning message to remind the related personnel for maintenance or replacement of the devices.

## Summary

To implement a track signal monitoring & control system, the system integrator who plan and build the system usually need to invest a huge amount in initial investment; and the cost for mid-term & long-term maintenance is also quite impressive. In recent years, with the hard-working of ICP DAS and its cooperate system integrator, ICP DAS has accumulated experience in this field. We believes that more cost-effective applications for track signal system will be developed in the near future.

# ZigBee Application - Emergency Bell Alarm System

By YY Chang

Emergency bell alarm system is often used in MRT, buildings, schools, hospitals and other public places for security management. When an accident occurs, one can press the alarm bell to immediately notify the related personnel, at the same time, the security control center will be informed the event's location and send the staff to take immediate actions right away.

## Description

Using the campus security management as an example, in a traditional alarm bell system, the alarm bell is installed in a restroom entrance and is only linked to a buzzer bell for regional alarm notification. But in such way, when encounters an emergency, the staffs of the security center can not be notified immediately and efficiently. To reply the emergency state to the host of the security control center, users must pay higher costs in wiring deployment to transmit the messages from multiple locations to the security control center; if these locations are widespread or across

different buildings, the costs are often quite expensive.

## ZT-IOG System is Perfect for Emergency Bell Alarm System

According to above application statement, in order to solve the difficulty and high cost problems of wiring deployment, ICP DAS provides the ZigBee wireless solution. The ZT-IOG system can automatically update the DIO channel status to the message center (ZigBee Coordinator) via the wireless communication, and then the message center will synchronize all DO channel status of the ZT-IOG network. This synchronization of

changing DO states may function as the "emergency alert" to trigger the alarm bell.

## Application Architecture Description

The emergency alarm bells may be installed in many places, every alarm bell should be able to actively upload events to the security center. The ZigBee network of the ZT-IOG modules is multi-to-multi I/O Pair-connection architecture, so the triggered event of any alarm bell will be updated to the message center.

The ZT-IOG network is a multi-to-multi I/O Pair-connection architecture, so when any alarm bell is triggered, it will link all ZT-IOG modules' mapping DO channel in the network. By applying "Pulse Mode" control logic, the user can install the alarm bells in many locations and link the warning devices of these locations, for example, link the alarm buzzers or video devices in multiple locations to multiple security control centers.

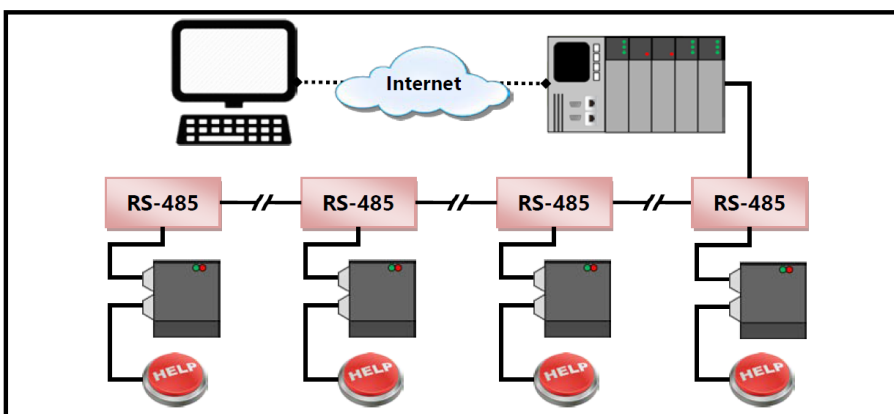



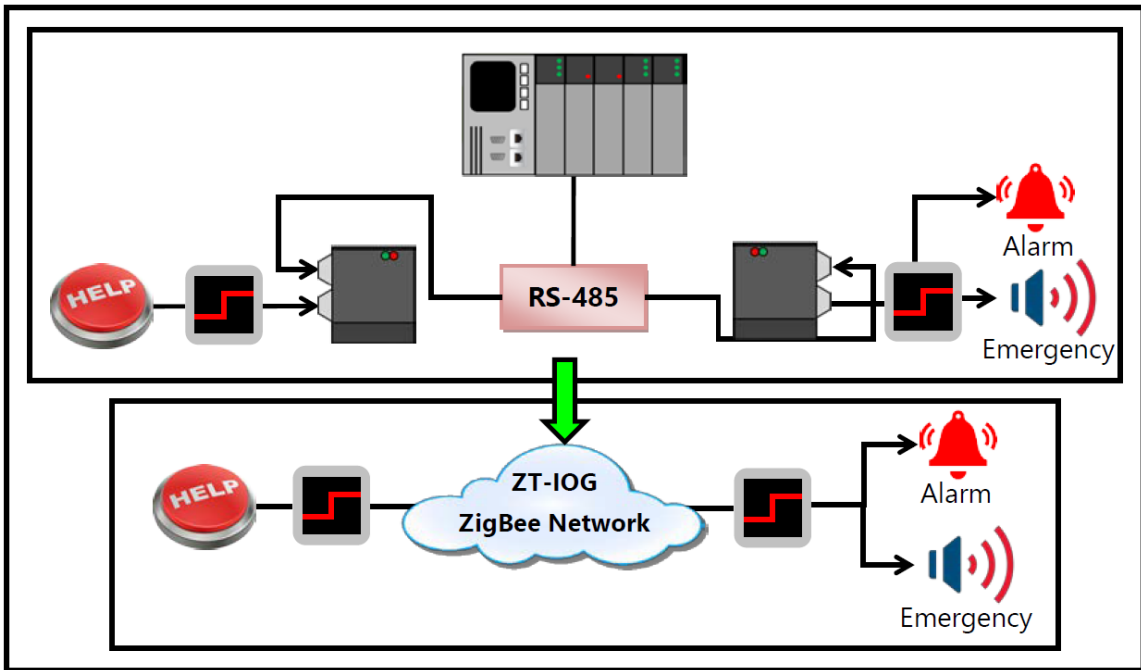

▲ ZigBee Network Alarm Bell System

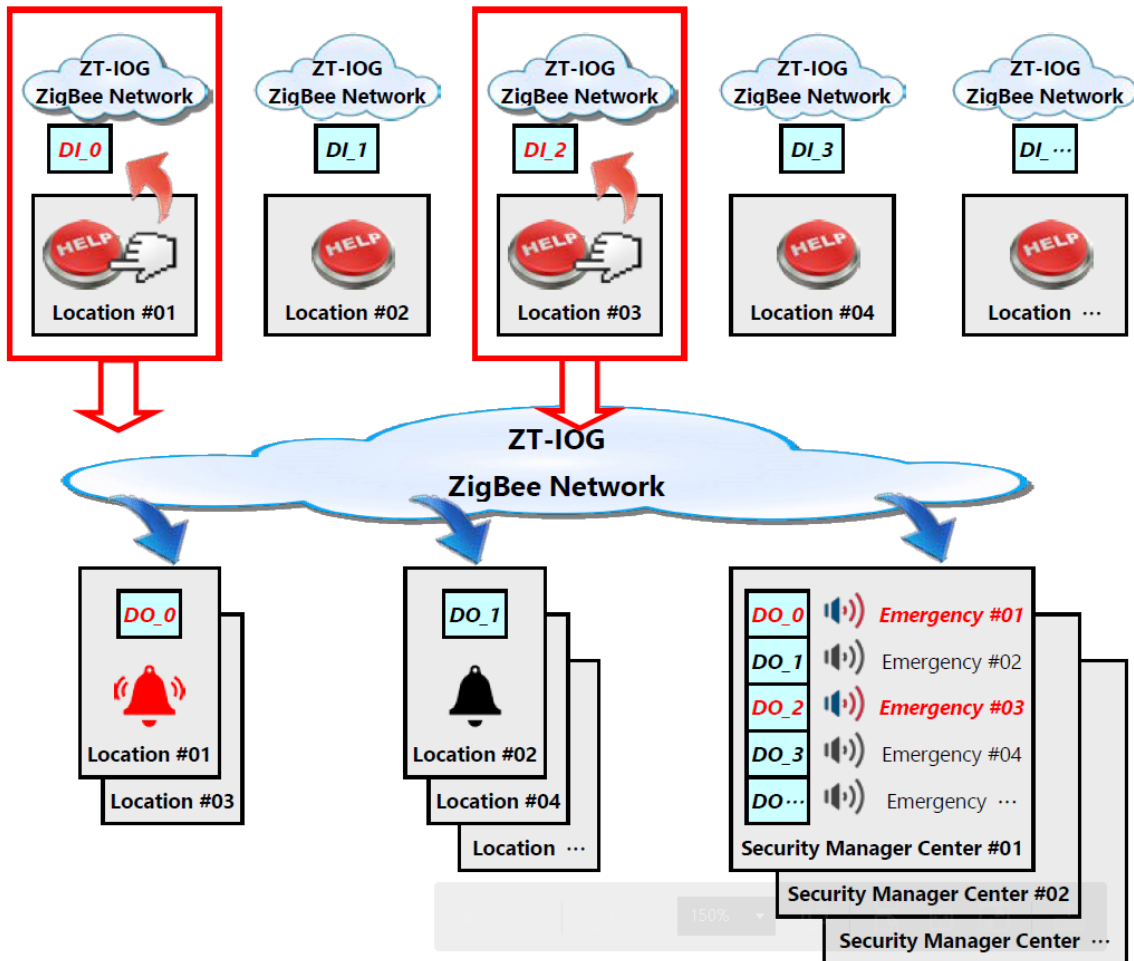

▲ ZigBee Network Alarm Bell System Architecture

## Event Triggering Modes

When applying ZT-IOG modules in different applications, the user can install different triggering devices according to the event mode of the application case.

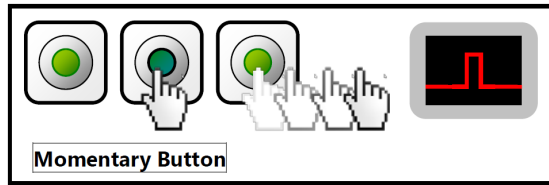

Each Push:  
Generate single pulse to invert the DO status.

▲ Momentary Button

(1) The lighting control system can apply the "Edge Mode" to "Momentary Button", so that multiple lights can be turned on or off simultaneously.

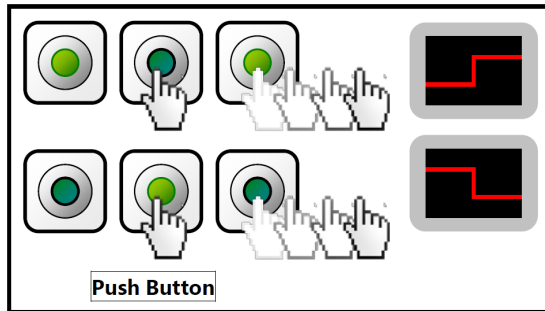

First Push: Low to High  
Second Push: High to Low  
Third Push: ...

▲ Push Button

(2) The emergency bell alarm system for fire safety can apply the "Level Mode" to "Push Button", so that the emergency alarm can be triggered and released at the same location.

(3) When installing the emergency bell alarm system for campus restroom, to avoid the emergency alerts being disabled intentionally; the "Emergency Button" cannot be restored easily; therefore it can be used as an alarm trigger when an emergency occurs.

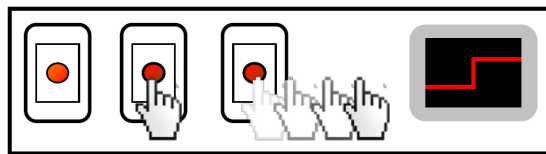

Single Push:  
Generate single rising signal and then locked.

▲ Emergency Button

# ZigBee Application - Route Management System for AGV

By YY Chang

In recent years, the system of unmanned factory or warehouse automation becomes popular, the Automatic Guided Vehicles (AGV) are used to transport goods in the product lines, storage systems, transfer stations, etc. When there are several AGV in one location, the vehicle driving routes may overlap, therefore to prevent the routes conflict is an important issue.

## Description

When an AGV is going to enter a restricted area, such as the main road, track or elevator..., the AGV needs to request the vehicle management center for entering permission. When the center accepts the request, the other AGV will no longer be able to enter that area until the AGV depart and the management center release the control, and then other AGV can apply to enter that restricted area.

According to the above application statement, each AGV can send messages to the vehicle management center, and can send an area disable message to other AGV in the region. The vehicle management center can be seen as a virtual cloud, it is a M2M (Machine to Machine) architecture. The AGV is a mobile device, so it needs a wireless device with the M2M architecture to do the message exchange.

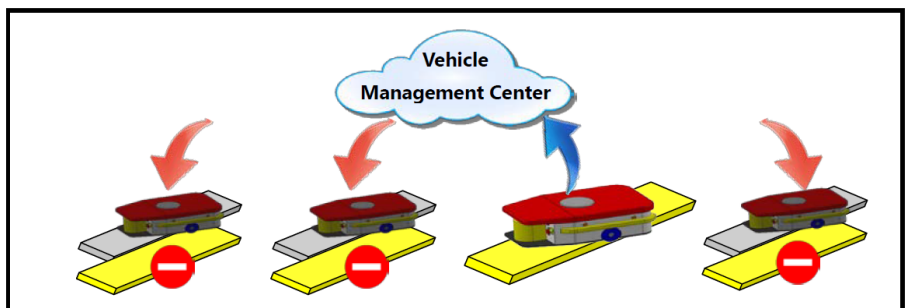
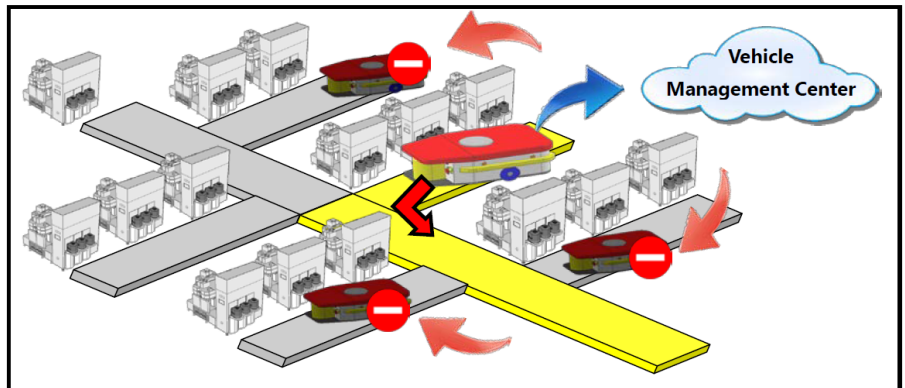

▲ The ZT-IOG System is Suitable for the AGV Route Management System

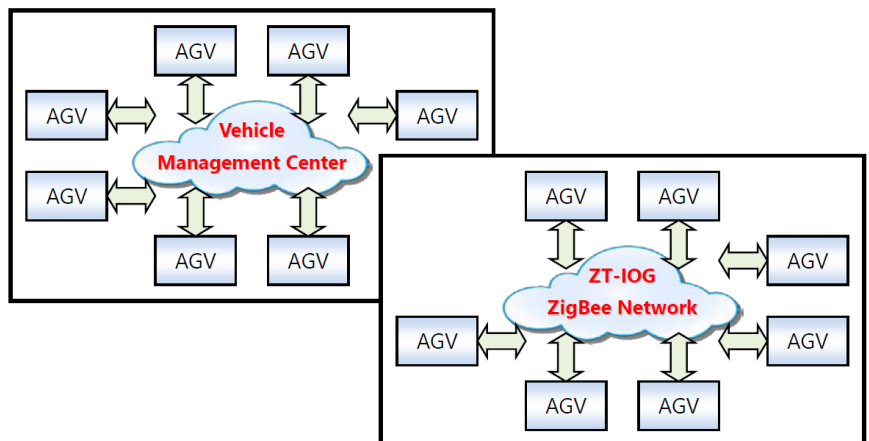

▲ ZigBee network



The ZT-IOG network is a multi-to-multi I/O Pair-connection architecture, so any ZT-IOG module in the ZigBee network can change the I/O channel state of the other ZT-IOG modules. This feature meets the requirement of this application, and thus achieves the purpose of the message exchange.

## Message Exchange

When an AGV is going to enter the restricted area, it must get the current status of the area, and update the status. In this case, the "On/Off" states of the DI/DO channels can be used to simulate the message of "occupied/idle" status and notify other AGV via the status of I/O channels to reach the route management goal.

## Application Architecture (i)

The architecture of the AGV route management system includes two levels:

(1) Control level: the AGV is equipped with PLC, PAC or IPC controller, etc. In addition to controlling the goods moving and the vehicle driving, it also manages the message exchange among vehicles in order to obtain the current route status and calculate the timing to enter the restricted area.

(2) Message exchange level: The ZT-IOG network can function as a medium of exchange messages. Not only simulate the "occupied/idle" status via the I/O "On/Off" status of the ZT-IOG module, but also automatically update the I/O states via the ZigBee wireless network to break the geographical limitation.

## The Actual Operation

When an AGV wants to enter the restricted area, its PLC of the control level will output a "high" state

to trigger the DI of the ZT-IOG module, meanwhile the DO of the ZT-IOG modules in the network will change to "high" based on the "Level Mode" Updating Logic, then will trigger the DI of the PLC on all vehicles to "high", and then they get the using status is "occupied", so that other vehicles will not enter this area for the safety reason. When this AGV leaves the restricted area, its PLC will cancel the "high" level state of the ZT-IOG, and then other AGV can send the requirement to enter this area again.

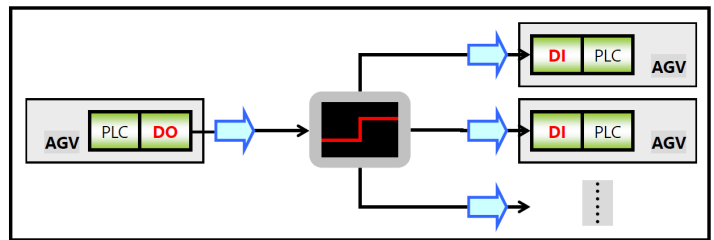

▲ Message Exchange

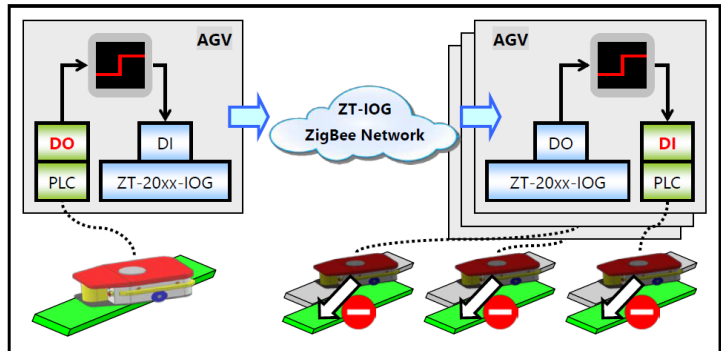
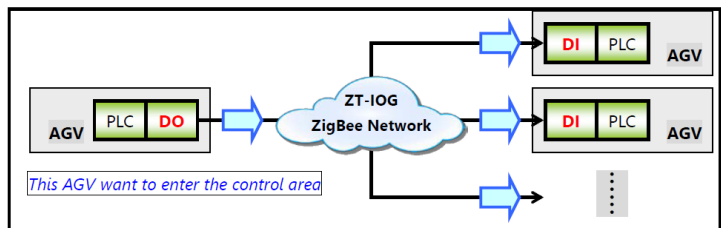

▲ The Actual Operation

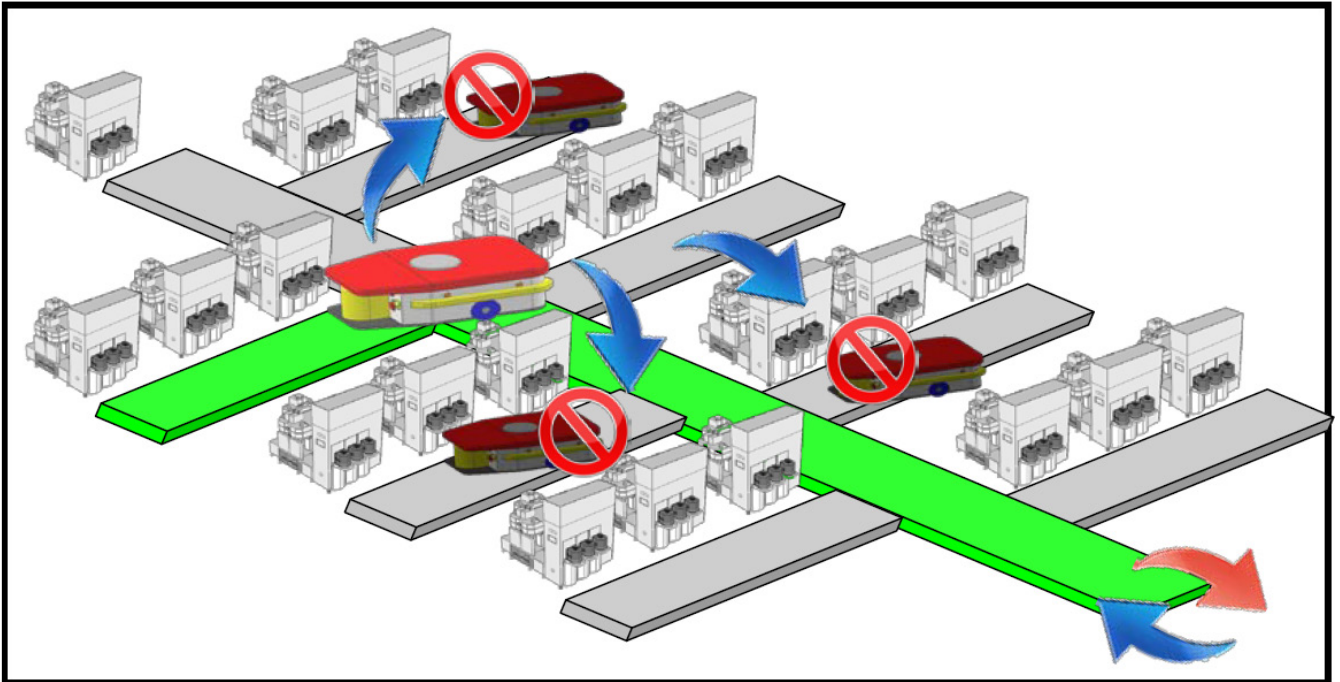

▲ Overall Architecture Diagram

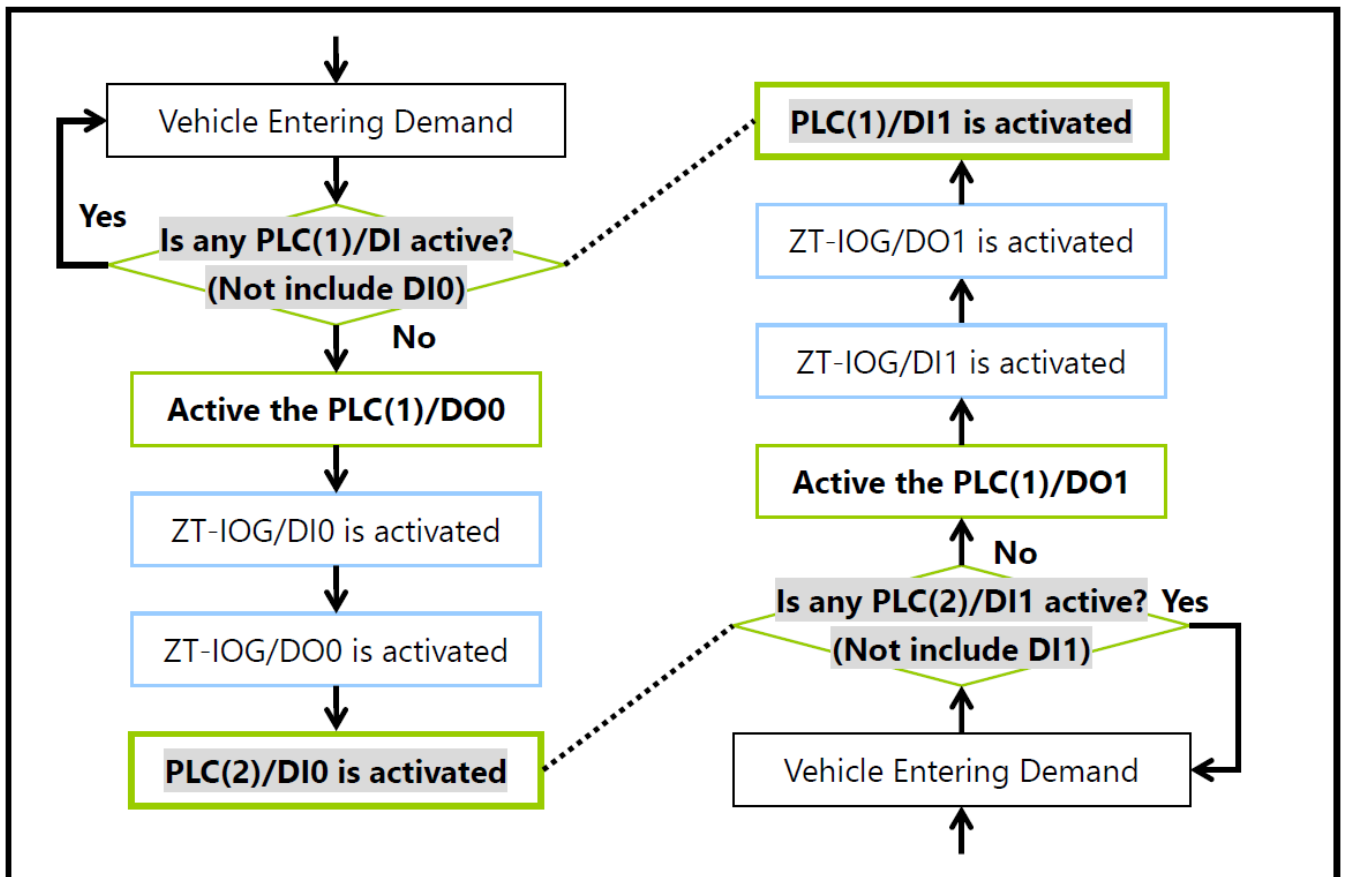

▲ Applications Logic Flow Chart

### Application Architecture (ii)

Based on the above application and architecture, in addition to use the "physical I/O" of the ZT-20xx-IOG modules to simulate "occupied/idle" status via the "On/Off" state, you can also use the serial port communication (RS-232/RS-485) on the PLC to achieve the message exchange function.

The ZT-257x module provides 280 pairs of virtual digital input/output channels that can access the virtual I/O channel by the Modbus RTU protocol, and the virtual I/O channel states still can Pair-connection with the physical I/O channel states. Its DI/DO works the same way, for more detailed description, please refer to the ZT-2570 and ZT-2571 module IOG mode at the below link.

[http://ftp.icpdas.com.tw/pub/cd/usbcd/napdos/zigbee/zt\\_series/document/zt-257x/](http://ftp.icpdas.com.tw/pub/cd/usbcd/napdos/zigbee/zt_series/document/zt-257x/)

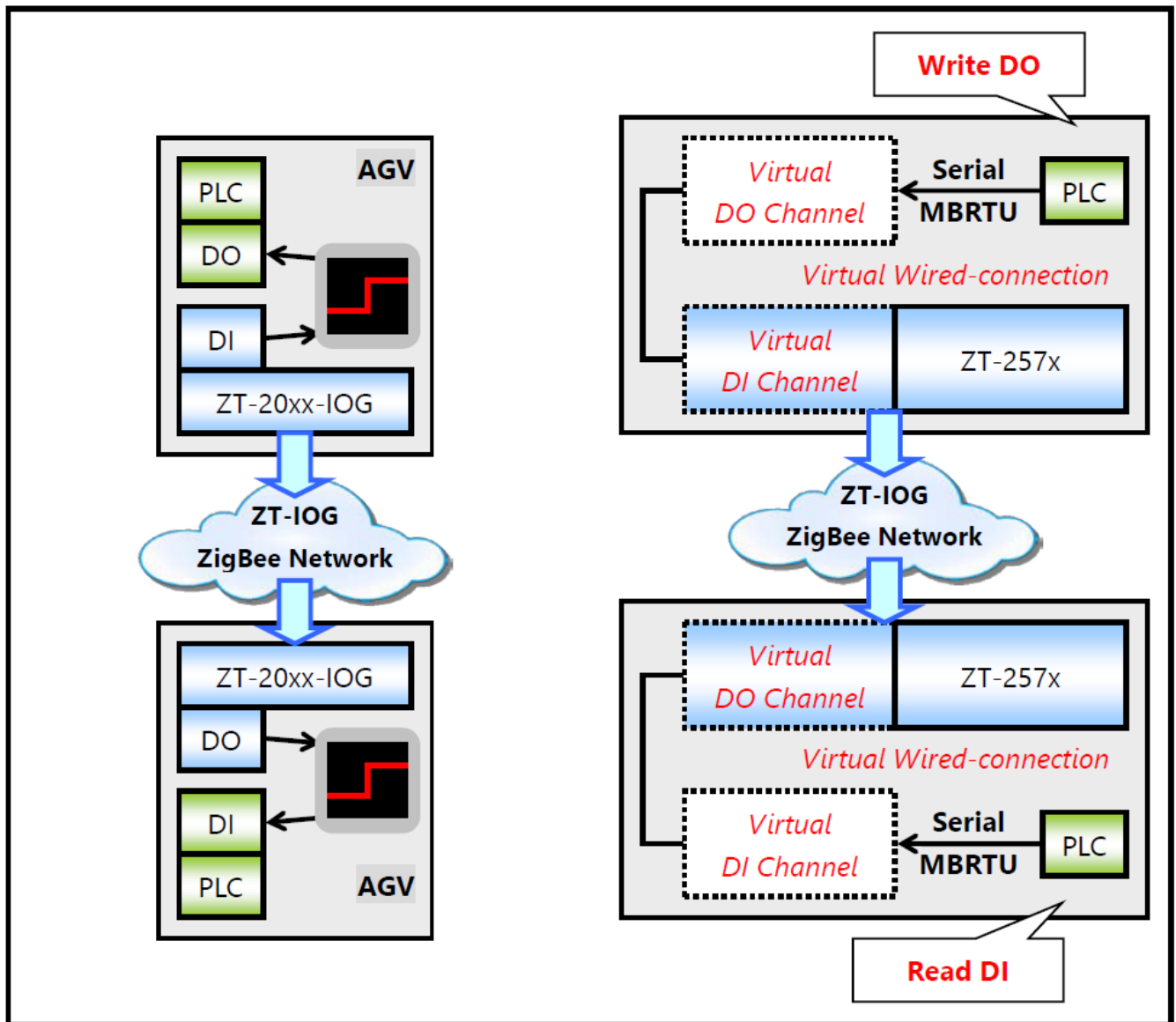

▲ Application Architecture



# ZigBee

## Total Solutions

### Wireless Mesh Networking



#### Features:

- ☑ ZigBee wireless solutions for Industry application, support up to 700M communication distance.
- ☑ Support intelligent automatic routing capabilities.
- ☑ Supports rich and complete product line; provides customers a variety of options.
- ☑ Offers a variety of ZigBee modules, including: AIO, DIO, Repeater, Converter, etc.
- ☑ Offers a variety of transmission modes, supports transparent, DCON and Modbus communication.
- ☑ Supports up to 255 ZT-2000 modules in the same network.
- ☑ User-friendly configuration tool; supports signal strength detection.

PC,PAC,PLC



Ethernet/RS-232/RS-485

**ZT-2570**  
Converter  
(Coordinator)



**ZT-2510**  
Repeater  
(Router)



**ZT-2551**  
Converter  
(Router)



**ZT-2571**  
Converter  
(Router)



**ZT-2017**  
AIO module



**ZT-2060**  
DIO module



Alert

Switch



Temperature  
Sensor



Meter

Instruments

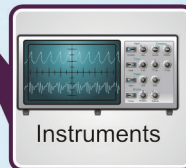

PLC



ICP DAS CO., LTD.

TEL : +886-3-597-3366 FAX : +886-3-597-3733 e-mail : sales@icpdas.com

<http://www.icpdas.com>