Getting Started : The XP-8xx7-CE6 PAC

The XP-8xx7-CE6 is the abbreviation of the XP-8047-CE6/8347-CE6/8747-CE6.
The XP-8xx6-CE6 is the abbreviation of the XP-8046-CE6/8346-CE6/8746-CE6.

Important Notice

1. **XP-8xx7-CE6/8xx6-CE6 supports only the High profile I-8K and I-87K I/O cards in its slot 1 to 7.** Please refer to XP-8xx7-CE6 CD: [\napdos\isagraf\xp-8xx7-ce6\english-manu\](#) for Data sheet.

2. Please always set a fixed IP address to the XP-8xx7-CE6. (No DHCP)

3. Please refer to the XP-8xx7-CE6 CD: [\napdos\isagraf\xp-8xx7-ce6\english-manu\](#) for the IP address setting.

4. Recommend to use the NS-205 or NS-208 Industrial Ethernet Switch for the XPAC.

Legal Liability

ICP DAS CO., LTD. assumes no liability for any and all damages that may be incurred by the user as a consequence of this product. **ICP DAS CO., LTD. reserves the right to change this manual at any time without notice.**

ICP DAS CO., LTD. constantly strives to provide our customers with the most reliable and accurate information possible regarding our products. However, ICP DAS CO., LTD. assumes no responsibility for its use, or for any infringements of patents or other rights of third parties resulting from its use.

Trademark & Copyright Notice

The names of products and name of company are used for identification purposes only, and are the registered trademarks of their respective owners or companies.

Development Software

Two options:

- ISaGRAF: Ver. 3.4x or Ver. 3.5x, IEC 61131-3 standard. LD, ST, FBD, SFC, IL & FC or
- Non-ISaGRAF: Microsoft EVC++4.0 or VS.NET 2008/2005/2003 (VB.net, C#.net)

Reference Guide

- = **GU**; **F5**: **9 b [`] g \ : I g Y f Đ g ` A U b i U `**

XP-8xx7-CE6 CD: [\napdos\isagraf\xp-8xx7-ce6\english-manu\](#) "user_manual_i_8xx7.pdf" & "user_manual_i_8xx7_appendix.pdf"

- ISaGRAF :

XP-8xx7-CE6 CD: [\napdos\isagraf\xp-8xx7-ce6\chinese-manu\](#)
"chinese_user_manual_i_8xx7.pdf"
"chinese_user_manual_i_8xx7_appendix.pdf"

- More from the Internet:

<http://www.icpdas.com/products/PAC/i-8000/isagraf.htm>

Technical Service

Please contact local agent or email problem-report to service@icpdas.com .

FAQ : <http://www.icpdas.com/faq/isagraf.htm>

*Written by Chun Tsai; Edited by Eva Li.
Copyright Oct. 2011, by ICP DAS CO., LTD. All Rights Reserved.*

Table of Contents

GETTING STARTED : THE XP8XX7-CE6 PAC.....	1
Important Notice.....	1
Legal Liability.....	1
Trademark & Copyright Notice.....	1
Development Software.....	1
Reference Guide.....	1
Technical Service.....	1
TABLE OF CONTENTS.....	2
REFERENCE GUIDE.....	6
I/O MODULES SELECTION GUIDE FOR XP8XX7-CE6 SERIES.....	7
PERFORMANCE COMPARISON TABLE OF ISAGRAFPACS.....	12
SPECIFICATIONS: XP8047CE6/ 8347CE6/ 8747CE6.....	13
CHAPTER 1 TYPICAL APPLICATION.....	2-1
1.1 Motion Control : Using-8094F/8092F/8094.....	2-1
1.2 SoftGRAF HMI : Create A Colorful HMI.....	2-2
1.3 eLogger HMI Application.....	2-3
1.4 Connect the Smart Power Meter PNB3/2134.....	2-4
1.5 Redundant Communication System.....	2-5
1.6 Redundant System Ethernet I/O.....	2-5
1.7 Redundant System Hot-Swap RS485 I/O.....	2-6
1.8 Redundant System with iDCS8000.....	2-6
1.9 Modbus Master: TCP/IP.....	2-7
1.10 Modbus Master: RTU, ASCII, RS32/485/422.....	2-7
1.11 Modbus Slave: RTU/TCP.....	2-8
1.12 Communicate With Other TCP/IP Server or UDP Client/Server Devices.....	2-8
1.13 Multiple Web HMI Monitor & Control Everywhere!.....	2-9
1.14 Send Email With or Without One Attached File.....	2-9
1.15 Data-Recorder & DataLogger.....	2-10
1.16 Remote I/O Application.....	2-10
1.17 SMS: Short Message Service.....	2-11
1.18 Auto-report Acquisition & Control Data.....	2-11
1.19 Stress Monitoring Application of Constructions.....	2-12
1.20 Fast FRnet Remote I/O.....	2-13
1.21 Integrate with CAN/CANopen Devices & Sensors.....	2-13
1.22 ZigBee Wireless Solution.....	2-14
1.23 GPS Application: with-87211W & GPS721.....	2-15
1.24 Data Exchange:Fbus or Ebus.....	2-16
1.25 Detect HotSwap I87K (High Profile) I/O Status.....	2-17
1.26 VIP Communication Security.....	2-17
1.27 Database Application.....	2-18
1.28 HART Solutions.....	2-19
CHAPTER 2 SOFTWARE INSTALLATION AND WORKING SOFT-GRAF HMI WITH ISAGRAF.....	2-1
2.1 Step 1-Installing The ISaGRAF Software.....	2-1

2.1.1	The hardware protection device (dongle & USB Key).....	2-3
2.1.2	Important Notice For Windows 2000 Users.....	2-4
2.1.3	Important Notice For Window NT Users.....	2-5
2.1.4	Important Notice for Windows Vista or Windows 7 (64) Users.....	2-6
2.1.5	Important Notice for Windows 7 (64) Users.....	2-8
2.1.6	Important Setting for Using Variable Arrays.....	2-8
2.2	Step 2- Installing The ICP DAS Utilities For ISaGRAF.....	2-9
2.3	Step 3- Installing The Web Page Editor.....	2-10
2.4	Working eLogger HMI with ISaGRAF SoftLogic.....	2-11
2.5	Working SoftGRAF HMI with ISaGRAF SoftLogic.....	2-12
CHAPTER 3	SETTING UP A WEB HM DEMO	3-1
3.1	Web Demo List.....	3-1
3.2	Steps To Set Up A Web HMI Demo.....	3-2
3.2.1	Step 1- Setup The Hardware.....	3-2
3.2.2	Step 2- Setting The Web Options.....	3-2
3.2.3	Step 3- Download ISaGRAF Project.....	3-3
3.2.4	Step 4- Download Web Pages To The XPAC.....	3-6
3.2.5	Step 5- Show Time.....	3-6
CHAPTER 4	PROGRAMMING A WEB HM EXAMPLE.....	4-1
4.1	Writing A Simple ISaGRAF Program.....	4-1
4.1.1	Open ISaGRAF-Project Management.....	4-2
4.1.2	#@ o8.k.....7.....y8.....	4-3
4.1.3	Creating A New ISaGRAF Project.....	4-3
4.1.4	Declaring The ISaGRAF Project Variables.....	4-4
4.1.5	Assign Modbus Network Address No to Variables.....	4-8
4.1.6	Create The LD "LD1" Program.....	4-9
4.1.7	Edit The "LD1" Program.....	4-10
4.1.8	Connecting The I/O.....	4-14
4.2	Compiling & Simulating The Example Project.....	4-17
4.3	Download & Debug The Example Project.....	4-21
4.4	Design The Web Page.....	4-26
4.4.1	Step 1 Copy The Sample Web HMI pages.....	4-26
4.4.2	Step 2 Building The Main.htm.....	4-27
4.4.3	Step 3 Adding Control Code To The Main.htm.....	4-32
4.4.4	Step 4 Download Web HMI Pages To The Controller.....	4-39
CHAPTER 5	WEB HMI BASICS.....	5-1
5.1	Basic Files For The Web HMI.....	5-1
5.2	Login.htm.....	5-2
5.3	Menu.htm.....	5-4
5.4	Main.htm.....	5-6
5.4.1	A Simple Main.htm Example.....	5-6
5.4.2	More About The refresh_data() Function And Dynamic Data.....	5-8
5.4.3	Post Data To The Controller.....	5-13
5.5	Multi-Pages.....	5-19
5.5.1	Level 2 And Level 3 Page.....	5-19
5.5.2	Switch One Page To One Another Page.....	5-20
5.6	Web Security.....	5-21
CHAPTER 6	VB.NET 2008 PROGRAM RUNNING IN XP-8XX7-CE6 ACCESS TO ISAGRAF VARIABLES.....	6-1

6.1	Create a New Project.....	6-1
6.2	Add Project Reference for an Application.....	6-2
6.3	Compiling an Application Program.....	6-5
6.4	QuickerNET.DLL.....	6-6
6.4.1	Digital R/W Functions.....	6-6
6.4.2	Analog R/W Functions.....	6-7
CHAPTER 7	7-1
CHAPTER 8	INDUSOFT PROJECT RUNNING IN XPAC ACCESS TO ISAGRAF VARIABLES.....	8-1
CHAPTER 9	EXAMPLE PROGRAM & FAQ.....	9-1
9.1	Get On-Line Help.....	9-1
9.2	Installing The ISaGRAF Programming Examples.....	9-4
9.3	Frequently Asked Questions.....	9-12
CHAPTER 10	C# .NET 2008 PROGRAM RUNNING IN THE XP8XX7-CE6 ACCESS TO ISAGRAF VARIABLES.....	10-1
10.1	Create a New Project.....	10-1
10.2	Add Project Reference for an Application.....	10-2
10.3	Compiling an Application Program.....	10-5
10.4	QuickerNET.DLL.....	10-6
10.4.1	Digital R/W Functions.....	10-6
10.4.2	Analog R/W Functions.....	10-7
CHAPTER 11	MOTION CONTROL- USING I-8094F/8092F/8094.....	11-1
11.1	Hardware / Software Requirement.....	11-1
11.2	Introduction and installation for I-8094F/8092F/8094.....	11-4
11.2.1	Introduction.....	11-4
11.2.2	Hardware Specification.....	11-4
11.2.3	Hardware Connection.....	11-4
11.2.4	Installation for the Motion Module.....	11-5
11.2.5	@ #.....	11-7
11.2.6	Install the I/O connection: i_8094f & i_8092f into the ISaGRAF.....	11-8
11.3	A simple Motion Example Using I-8094F Module.....	11-10
11.3.1	Create an ISaGRAF Motion Project.....	11-10
11.3.2	Set up I/O connection.....	11-21
11.3.3	Compile, Download and execute the project.....	11-22
11.4	Descriptions for the Setting of I/O Connection.....	11-24
11.5	The Motion Control Programming Steps for ISaGRAF.....	11-29
11.5.1	The Motion Control Steps.....	11-29
11.5.2	The I-8092F Example.....	11-31
11.6	ISaGRAF Function Descriptions.....	11-37
11.6.1	Notice in using motion functions.....	11-37
11.6.2	I-8094F /-8092F /-8094 Functions:.....	11-38
Z_S_RANG	I-8094F I-8092F I-8094.....	11-38
Z_S_HOME	I-8094F I-8092F I-8094.....	11-40
Z_SRV_ON	I-8094F I-8092F I-8094.....	11-40
Z_HOME	I-8094F I-8092F I-8094.....	11-41
Z_DONE	I-8094F I-8092F I-8094.....	11-41
Z_NHO_SH	I-8094F I-8092F I-8094.....	11-42
Z_HOM_SH	I-8094F I-8092F I-8094.....	11-42

Z_PHA_SH	I-8094F	I-8092F	I-8094.....	11-43
Z_S_ENCO	I-8094F	I-8092F	I-8094.....	11-43
Z_PT	I-8094F	I-8092F	I-8094.....	11-44
Z_PT2	I-8094F	I-8092F	I-8094.....	11-45
Z_PT3	I-8094F	I-8092F	I-8094.....	11-46
Z_ARC2	I-8094F	I-8092F	I-8094.....	11-47
Z_CON_MV	I-8094F	I-8092F	I-8094.....	11-48
Z_VEL_MV	I-8094F	I-8092F	I-8094.....	11-48
Z_DRV	I-8094F	I-8092F	I-8094.....	11-49
Z_STOP	I-8094F	I-8092F	I-8094.....	11-49
Z_MPG	I-8094F	I-8092F	I-8094.....	11-50
Z_GET_SP	I-8094F	I-8092F	I-8094.....	11-50
Z_GET_AC	I-8094F	I-8092F	I-8094.....	11-51
ZC_BEGIN	I-8094F	I-8092F	I-8094.....	11-51
ZC_READY	I-8094F	I-8092F	I-8094.....	11-52
ZC_END	I-8094F	I-8092F	I-8094.....	11-52
ZC_PT2	I-8094F	I-8092F	I-8094.....	11-53
ZC_PT3	I-8094F	I-8092F	I-8094.....	11-54
ZC_ARC2	I-8094F	I-8092F	I-8094.....	11-55
11.7	Motion Demo Programs.....				11-56
11.7.1	The List of ISaGRAF Motion Demos with ISaGRAF HMI.....				11-56
11.8	How to Copy One Single Motion Function				11-59
11.9	Error Code List for the Function Return.....				11-60
APPENDIX A	HARDWARE SYSTEM & SETTING.....				1
A.1	Applying Correct Power Supply.....				1
A.2	Modify The NETID & Modbus RTU Port Setting.....				2
A.3	Setting The IP Address For XP-8xx7-CE6				3
A.4	Connecting PC To XP-8xx7-CE6 Ethernet Port.....				4
A.5	Pin Assignment of COM1~COM5 and Multi Clients Connection.....				5
A.6	Connecting PC To XP-8xx7-CE6 COMPorts.....				6
A.7	Deleting the ISaGRAF Project From XP-8xx7-CE6				7
A.8	Linking I7000 and 87K Modules For Remote I/O.....				8
A.9	Linking To An HMI Interface Device				9
A.10	Linking To Other Modbus Devices.....				10
APPENDIX B	y h 8 k °) - ' CEh AF#DRIVER TO NEWER VERSION.....				11
APPENDIX C	DIMENSION.....				14
APPENDIX D	HOW TO ENABLE/DISABLE XP-8XX7-# - oQ.....V.....				17
APPENDIX E	USING EXPANSION RS232/485/422.....				18
APPENDIX F	SLOW DOWN ISAGRAF DR@ † - k oo.h.....).....				23
APPENDIX G	SETUP MORE MODBUS RØ SALVE PORTS.....				24
APPENDIX H	COMPILING ERROR RESULT IN DIFFERENT ISAGRAF VERSION.....				26
APPENDIX I	USING RS-232 SERIAL/USB TOUCHMONITOR.....				27
APPENDIX J	WHY MY PC RUNNING ISAGRAF CANNOT CONNECTTHE ISAGRAF PAC CORRECTLY ?30				
APPENDIX K	ENABLE THE SCREEN SWAE OF XPAC.....				31

Reference Guide

= G U ; F 5 : ' I g Y f (English Manual):`

XP-8xx7-CE6 CD: \napdos\isagraf\xp-8xx7-ce6\english-manu\
"user_manual_i_8xx7.pdf" & "user_manual_i_8xx7_Appendix.pdf"
http://www.icpdas.com/products/PAC/i-8000/getting_started_manual.htm

ISaGRAF (Chinese Manual):

XP-8xx7-CE6 CD: \napdos\isagraf\xp-8xx7-ce6\chinese-manu\
"chinese_user_manual_i_8xx7.pdf" & "chinese_user_manual_i_8xx7_Appendix.pdf"
http://www.icpdas.com/products/PAC/i-8000/getting_started_manual.htm

Industrial Ethernet Switch : NS-205/NS-208

http://www.icpdas.com/products/Switch/switch_list.htm



Model: NS-205



Model: NS-208

Power Supply :

http://www.icpdas.com/products/Accessories/power_supply/power_list.htm

DP-660 : 24 V / 2.5 A , 5 V / 0.5 A power supply (DIN-Rail mounting)
DP-665 : 24 V / 2.5 A , 5 V / 0.5 A power supply
DP-1200 : 24 V / 5 A power supply



Model: DP-660



Model: DP-1200



Model: DP -665

FAQ:

www.icpdas.com > FAQ > Software > ISaGRAF for Frequently Asked Questions.
<http://www.icpdas.com/faq/isagraf.htm>

I/O Modules Selection Guide for XP-8xx7-CE6 Series

XP-8xx7-CE6 supports the **I-8K/I-87K High Profile I/O** modules and RS-485 / FRnet remote I/O modules listed in the [ISaGRAF Data Sheet](#) . Please refer to the list in the next page or follow the below steps to get the newest list.

1. www.icpdas.com

The screenshot shows the ICP DAS website homepage. A red callout box highlights the address bar containing 'http://www.icpdas.com'. The website features a navigation menu with options like Home, About, Company, Products, Download, Certification, Application Stories, FAQ, and News & Events. A central banner for 'ViewPAC Family' is visible, along with a sidebar on the right listing various products like Industrial Fiber Switch, VXC Card, PDS, and ET-7000.

3. Data Sheet

The screenshot shows the ISaGRAF Data Sheet page. A red callout box highlights the 'Data Sheet' link in the right-hand sidebar. The main content area features a central diagram of the ISaGRAF PAC system, showing connections to various protocols and devices. The diagram includes labels for WinPAC, IPAC, ViewPAC, HMI & SCADA Software, Modbus RTU Slave Protocol, and DCON Protocol. A sidebar on the left lists various ISaGRAF PAC models and their features.

High Speed Local I/O Modules: Parallel Bus

I-8K High Profile Modules: More at www.icpdas.com > Products > PAC - 8K & 87K I/O Modules

I-8K Analog I/O Modules	
I-8014W	16-bit 250K sampling rate 8/16-ch. analog input module (The scan rate cannot reach 250K when using in the ISaGRAF PAC)
I-8017HW	8-ch. Differential or 16-ch. Single-ended, 14-bit, High Speed Analog Input Module. (current input require external 125 K resistor) (The scan rate cannot reach 100K when using in the ISaGRAF PAC)
I-8024W	4-ch. Isolated Analog Output Module (+/-10 V, 0 ~ +20 mA)
I-8K Digital I/O Modules	
I-8037W	16-ch. Isolated Open Collector Output Module
I-8040W	32-ch. Isolated Digital Input Module
I-8040PW	32-ch. Isolated Digital Input with Low Pass Filter Module
I-8041W	32-ch. Isolated Open Collector Digital Output Module (Sink)
I-8041AW	32-ch. Isolated Open Collector Digital Output Module (Source)
I-8042W	16-ch. Isolated Digital Input & 16-ch. Isolated Open Collector Digital Output Module
I-8046W	16-ch. Isolated Digital Input Module
I-8050W	16-ch. Universal Digital I/O Module
I-8051W	16-ch. Non-isolated Digital Input Module
I-8052W	8-ch. Differential Isolated Digital Input Module
I-8053W	16-ch. Isolated Digital Input Module
I-8053PW	16-ch. Isolated Digital Input with Low Pass Filter Module
I-8054W	8-ch. Isolated Digital Input Module & 8-ch. Isolated Open Collector Digital Output Module
I-8055W	Non-isolated 8-ch. Digital Logic Input Module & 8-ch. Open Collector Digital Output Module
I-8056W	16-ch. Non-isolated Open Collector Output Module
I-8057W	16-ch. Isolated Open Collector Output Module
I-8058W	8-ch. Differential Isolated Digital Input Module, Max. AC/DC Input : 250V
I-8060W	6-ch. Relay Output Module, AC: 0.6 A @ 125 V , 0.3 A @ 250 V; DC: 2 A @ 30 V
I-8063W	4-ch. Differential Isolated digital input & 4-ch. Relay output module, AC : 0.6 A @ 125 V ; 0.3 A @ 250 V
I-8064W	8-ch. Power Relay Output Module, AC: 5 A @ 250 V, DC: 5 A @ 30 V
I-8068W	4-ch. Form-A, 5 A @ 250 V _{AC} /28 V _{DC} & 4-ch. Form-C, 5 A (NO) /3 A (NC) @ 277 V _{AC} /30 V _{DC} Relay Output Module
I-8069W	8-ch. PhotoMOS Relay Output Module, Max. AC/DC: 1 A @ 60 V
I-8K Counter/Frequency Modules	
I-8084W	4-ch. Encoder, can be dir/pulse, or up/down or A/B phase (Quad. mode), Not support Encoder Z-index
I-8088W	8-ch. PWM Output and 8-ch. isolated DI Module, software support 1 Hz ~ 100 kHz (non-continuous).
I-8K Motion Modules	

I-8093W	3-axis Encoder Module, max. 1M Hz for quadrant input mode, max. 4M Hz for pulse/direction and cw/ccw input model
I-8090W	3-axis Encoder Module
I-8091W	2-axis Stepping/Servo Motor Control Card without encoder input
I-8092F	High Speed 2-axis Motion Control Module, with FRnet Master (For XP-8xx7-CE6 only)
I-8094	High Speed 4-axis Motion Control Module (For XP-8xx7-CE6 only)
I-8094F	High Speed 4-axis Motion Control Module, with FRnet Master (For XP-8xx7-CE6 only)
I-8K Communication Modules	
I-8112iW	2-ch. Isolated RS-232 Expansion Module
I-8114W	4-ch. non-isolated RS-232 Expansion Module
I-8114iW	4-ch. Isolated RS-232 Expansion Module
I-8142iW	2-ch. Isolated RS-422/485 Expansion Module
I-8144iW	4-ch. Isolated RS-422/485 Expansion Module
I-8172W	2-port FRnet Module
I-8K CAN Bus Modules	
I-8123W	1 Port High Performance CANopen Master Module

RS-485 Remote I/O Modules: Serial Interface; HOT-SWAP

I-87K High Profile Modules: More at www.icpdas.com > Products > PAC - 8K & 87K I/O Modules

I-87K Analog I/O Modules	
I-87005W	8-ch. Thermistor input and 8-ch. digital output module
I-87013W	4-ch., 16-bit, 10 Hz (Total), 2/3/4 Wire RTD Input Module with Open Wire Detection
I-87015W	7-ch., 16-bit, 12 Hz (Total), RTD Input Module with Open Wire Detection (for short sensor distance)
I-87015PW	7-ch. RTD Input Module with 3-wire RTD lead resistance elimination and with Open Wire Detection (for long sensor distance)
I-87017RW	8-ch. Differential , 16/12-bit, 10/60 Hz (Total) Analog Input Module with 240 V _{rms} Over Voltage Protection, Range of -20 ~ +20 mA Requires Optional External
I-87017RCW	8-ch. Differential , 16/12-bit, 10/60 Hz(Total) Current Input Module
I-87017W	8-ch. Analog Input Module
I-87017W-A5	8-ch. High Voltage Input Module
I-87017DW	8-ch. Analog Input Module (Gray Cover) (RoHS)
I-87017ZW	10/20-ch. Analog Input Module with High Voltage Protection (RoHS)
I-87018PW	8-ch. Thermocouple Input Module (Gray Cover) (RoHS)
I-87018RW	8-ch. Thermocouple Input Module. Recommend to use the better I-87018Z.
I-87018W	8-ch. Thermocouple Input Module. Recommend to use the better I-87018Z.
I-87018ZW	10-ch. Differential , 16-bit, 10 Hz (Total), Thermocouple Input Module with 240 V _{rms} Over Voltage Protection, Open Wire Detection, Range of +/-20 mA, 0~20 mA, 4~20 mA requires Optional External 125 Resistor
I-87019PW	8-ch. Universal Analog Input Module (RoHS) (With a CN-1824 Daughter Board)
I-87019RW	8-ch. Diff. , 16-bit, 8 Hz (Total), Universal Analog Input Module with 240 V _{rms} Over Voltage Protection, Open Wire Detection (V, mA, Thermocouple; Range

	of -20 ~ +20 mA need to set Jumper on board)
I-87019ZW	10-ch. Universal Analog Input Module (Gray Cover) (RoHS), Includes the I-87019ZW Module and a DB-1820 Daughter Board
I-87024CW	4-ch. 12-bit channel to channel isolated current output module with open-wire detection
I-87024DW	4-ch. 14-bit analog output module
I-87024RW	4-ch. 14-bit analog output module
I-87024W	4-ch. 14-bit analog output module (0 ~ +5 V, +/-5 V, 0 ~ +10 V, +/-10 V, 0 ~ +20 mA, +4 ~ +20 mA)
I-87028CW	8-ch. 12-bit current output module
I-87H17W	8-ch. analog input module and HART master module.
I-87K Multifunction I/O Modules	
I-87026PW	6-ch. Analog Input, 2-ch. Analog Output, 2-ch. Digital Input and 2-ch. Digital Output Module (RoHS)
I-87K Digital I/O Modules	
I-87037W	16-ch. source type Isolated Digital Output Module(RoHS)
I-87040W	32-ch. Isolated Digital Input Module
I-87040PW	32-ch. Isolated Digital Input Module with 16-bit Counters (RoHS)
I-87041W	32-ch. Sink Type Open Collector Isolated Digital Output Module
I-87046W	16-ch. Non-Isolated Digital Input Module for Long Distance Measurement
I-87051W	16-ch. Non-Isolated Digital Input Module
I-87052W	8-ch. Differential , Isolated Digital Input Module
I-87053PW	16-ch. Isolated Digital Input Module with 16-bit Counters
I-87053W	16-ch. Isolated Digital Input Module
I-87053W-A5	16-ch. 68 ~ 150 V _{DC} Isolated Digital Input Module
I-87053W-AC1	16-ch. AC Isolated Digital Input Module with 16-bit Counters
I-87053W-E5	16-channel 68-150 V _{DC} isolated Digital Input Module with 16-bit Counters
I-87054W	Isolated 8-ch. DI and 8-ch. Open Collector DO Module
I-87055W	Non-Isolated 8-ch. DI and 8-ch. Open Collector DO Module
I-87057W	16-ch. Open Collector Isolated Digital Output Module
I-87057PW	16-ch. Open Collector Isolated Digital Output Module
I-87058W	8-ch. 80~250 V _{AC} Isolated Digital Input Module
I-87059W	8-ch. Differential 10-80 V _{AC} Isolated Digital Input Module
I-87061W	16-ch. Relay Output Module (RoHS)
I-87063W	4-ch. Differential Isolated Digital Input and 4-ch. Relay Output Module 5 A (NO) / 3 A(NC) @ 5 ~ 24 V _{DC} ; 5 A(NO) / 3 A(NC) @ 0 ~ 250 V _{AC}
I-87064W	8-ch. Relay Output Module, 5 A (47~63 Hz) @ 0~ 250 V _{AC} ; 5 A @ 0~ 30 V _{DC}
I-87065W	8-ch. AC SSR Output Module, AC: 1.0 A _{rms} @ 24 ~ 265 V _{rms}
I-87066W	8-ch. DC SSR Output Module , DC: 1.0 A _{rms} @ 3 ~ 30 V _{DC}
I-87068W	4-ch. Form-A Relay Output and 4-ch. Form-C Relay Output Module ; Form-A: 8 A @ 250 V _{AC} ; 8 A @ 28 V _{DC} ; Form-C: 5 A (NO) / 3 A (NC) @ 277 V _{AC} ; 5 A(NO) / 3 A(NC) @ 30 V _{AC}
I-87069W	8-ch. PhotoMOS Relay Output Module, Max. AC/DC: 0.13 A @ 350 V
I-87K Counter/Frequency Modules	
I-87082W	2-ch. Counter/Frequency Module, Isolated or Non-isolated Inputs
I-87K PWMS Modules	
I-87088W	8-ch. PWM outputs, software support 1 Hz~100 kHz, (non-continuous), duty:

	0.1 ~ 99.9%
I-87K GPS Modules	
I-87211W	Time-Synchronization and GPS module for getting UTC/local time and local Longitude/Latitude

RS-485 Remote I/O Modules	
I-7000 DCON Protocol	www.icpdas.com.tw > Product > Solutions > Remote I/O Modules/Units > RS-485 Remote I/O Modules > I-7000 Modules
M-7000 Modbus RTU and DCON Protocol	www.icpdas.com.tw > Product > Solutions > Remote I/O Modules/Units > RS-485 Remote I/O Modules > M-7000 Modules
tM-7000 DCON, Modbus RTU, Modbus ASCII Protocol	www.icpdas.com.tw > Product > Solutions > Remote I/O Modules/Units > RS-485 Remote I/O Modules > tM Series Module
RS-485 Remote I/O Expansion Unit	
RU-87P1/2/4/8 Hot-Swap, Auto-Config.	www.icpdas.com.tw > Product > Solutions > Remote I/O Modules/Units > Remote I/O Expansion Unit > RS-485 Bus
I-87K1/4/5/8/9	www.icpdas.com.tw > Product > Solutions > Remote I/O Modules/Units > Remote I/O Expansion Unit > RS-485 Bus

Ethernet I/O Modules	
ET-7000 Web based	www.icpdas.com.tw > Product > Solutions > Remote I/O Modules/Units > Ethernet I/O > ET-7000
PET-7000 PoE Web based	www.icpdas.com.tw > Product > Solutions > Remote I/O Modules/Units > Ethernet I/O > PET-7000
tPET/tET-7000 Modbus TCP based (PoE)	www.icpdas.com.tw > Product > Solutions > Remote I/O Modules/Units > Ethernet I/O > PETL-7000 & tPET/tET
Ethernet I/O Expansion Unit	
I-8KE4/8-MTCP Modbus/TCP based	www.icpdas.com.tw > Product > Solutions > Remote I/O Modules/Units > Ethernet I/O > I-8KE4/8-MTCP

Performance Comparison Table of ISaGRAF PACs

Please click on the link [ISaGRAF Comparison Table](#) or follow the below steps:

The screenshot shows the ICP DAS website homepage. A red callout box highlights the address bar containing the URL "1. www.icpdas.com". The website features a navigation menu with options like Home, About Company, Products, Download, Distributors, Partners, Training, Activity, and Catalog. The main content area displays the "ViewPAC Family" as "The All-in-One Control Unit" with features like Touch Screen, Programmable Keypads, and Optional Operation System. A sidebar on the right lists various industrial products such as Industrial Fiber Switch, Ethernet Switch, VXC Card, and PDS. A second red callout box points to a link in the bottom left corner labeled "2. Click here to go to the ISaGRAF page".

The screenshot shows the ISaGRAF website. The main content area features a central diagram of the "ISaGRAF PAC" system, showing a globe with various protocols and components like WinPAC, IPAC, ViewPAC, and HMI & SCADA Software. The sidebar on the left contains a "Language" section (中文), "Topics" (What is ISaGRAF, Hot Features, Ordering Information, Selection Guide, Related Products), and a list of "ISaGRAF PACs" including models like XP-8xx7-CE6, WP-8x37/8x47, VP-25W7/23W7, VP-2117, IP-8x47, I-8xx7 & I-8x37-80, μPAC-7186EG, I-7188EG, and I-7188XG. A red callout box highlights the "Comparison Table (All)" link in the sidebar. The right sidebar contains icons for "ISaGRAF V3.5x", "Driver", "Manual", "Data Sheet", "Demo Files", "Download All", and "FAQ".

Specifications: XP-8047-CE6/ 8347-CE6/ 8747-CE6

PAC Specifications:

Models	XP -8047 -CE6	XP -8347 -CE6	XP -8747 -CE6
System Software			
OS	Windows CE 6.0 R3 Core		
.Net Compact Framework	3.5		
Embedded Service	FTP Server, ASP (Java Script, VB Script), SQL Compact Edition 3.5		
SDK Provided	DII for Visual Studio .Net 2005/2008		
Multilanguage Support	English, German, French, Spanish, Russian, Italian, Japanese, Simplified Chinese, Traditional Chinese		
Development Software			
ISaGRAF Software	ISaGRAF Ver.3	IEC 61131-3 standard.	
	Languages	LD, ST, FBD, SFC, IL & FC Support Soft-GRAF HMI: XP -8xx7-CE6, WP-8xx7, VP-2xW7 and WP-5xx7 PAC	
	Max. Code Size	2 MB	
	Scan Time	3 - 15 ms for normal program 15 - 50 ms (or more) for complex or large program	
Non-ISaGRAF	Options: VS.NET 2005/2008 (VB.NET, C#.NET)		
Web Service			
Web HMI	PC running Internet Explorer can monitor/control PAC via Internet/modem		
Security	Web HMI supports three levels username and password protection. (high/middle/low)		
CPU Module			
CPU	LX800, 500 MHz		
System Memory	512 MB DDR SDRAM		
Dual Battery Backup SRAM	512 KB; data valid up to 5 years (for retain variables)		
Flash	4 GB as IDE Master		
EEPROM	16 KB		
CF Card	2 GB (support up to 32 GB)		
RTC (Real Time Clock)	Provide second, minute, hour, date, day of week, month, year		
64-bit Hardware Serial Number	Yes, for Software Copy Protection		
Dual Watchdog Timers	Yes		
Rotary Switch	Yes (0 - 9)		

Models	XP -8047 -CE6	XP -8347 -CE6	XP -8747 -CE6
DIP Switch	-	Yes (8 bits)	
VGA & Communication Ports			
VGA	Yes, (resolution: 1024 x 768, 800 x 600, 640 x480)		
Ethernet	RJ-45 x 2, 10/100 BaseTX (Auto-negotiating, Auto MDI/MDI-X, LED indicators).		
USB 2.0	2		
COM 1	RS-232 (Rx/D, Tx/D and GND); non-isolated	Internal communication with the high profile I-87K series modules in slots	
COM 2	RS-232 (Rx/D, Tx/D and GND); non -isolated		
COM 3	RS-485 (Data+, Data -) with internal selftuner ASIC; 3000 VDC isolated		
COM 4	RS-232/RS485 (Rx/D, Tx/D, CTS, RTS and GND for RS -232, Data+ and Data- for RS-485); non-isolated		
COM 5	RS-232 (Rx/D, Tx/D, CTS, RTS, DSR, DTR, CD, RI and GND); non -isolated		
I/O Expansion Slots			
Slot Number	0	3	7
	Note: For High Profile I-8K and I-87K Modules Only		
Mechanical			
Dimensions (W x L x H)	137 x 132 x 125 mm	231 x 132 x 125 mm	355 x 132 x 125mm
Installation	DIN -Rail or Wall Mounting		
Environmental			
Operating Temperature	-25 ~ +75°C		
Storage Temperature	-30 ~ +80°C		
Ambient Relative Humidity	10 ~ 90% RH (non -condensing)		
Power			
Input Range	+10 ~ +30 VDC		
Isolation	1 kV		
Redundant Power Inputs	Yes, with one power relay (1 A @ 24 VDC) for alarm		
Capacity	15 W	35 W	35 W
Consumption	14.4 W	14.4 W	16.8 W

XP-8xx7-CE6 ISaGRAF Specifications:

Models	XP -8047 -CE6	XP -8347 -CE6	XP -8747 -CE6
Protocols (some protocols need optional devices)			

Models	XP -8047 -CE6	XP -8347 -CE6	XP -8747 -CE6
Net ID	1 ~ 255, user-assigned by software		
Modbus TCP/IP Master	Link to max. 100 devices that support Standard Modbus TCP/IP Slave protocol (FAQ-113)		
Modbus RTU/ASCII Master	Max. 33 Ports : COM1 ~ 33 (To connect to other Modbus Slave devices)(*)		
Modbus RTU Slave	Max. 9 Ports : COM1 ~ 33 (For connecting ISaGRAF, PC/HMI/OPC Server & HMI panels). (*)		
Modbus TCP/IP Slave	2 Ethernet Ports all support Modbus TCP/IP Slave protocol for connecting ISaGRAF & PC/HMI. 2 Ports support up to 64 connections. Note: If PAC uses 1 connection to connect each PC/HMI, it can connect up to 64 PC/HMI; If PAC use 2 connections to connect each PC/HMI, it can connect up to 32 PC/HMI; When one Ethernet port is broken, the other one can still connect to PC/HMI.		
Web HMI Protocol	Ethernet Ports for connecting PC running Internet Explorer.		
User-Defined Protocol	User can write his own protocol applied at COM1~COM5 & COM6~COM33 by Serial communication function blocks. (*)		
I-7000 & I-87K RS-485 Remote I/O	One of COM3~4 supports I-7000 I/O modules, I-87K base + I-87K Serial I/O boards or RU-87Pn + I-87K High Profile I/O boards as remote I/O. Max. 255 modules of I-7000/87K Remote I/O for one PAC.		
M-7000 Series Modbus I/O	Max. 33 RS-485 ports. Each port can connect up to 32 M7000 Modules. (*)		
Modbus TCP/IP I/O	LAN2 supports ICP DAS Ethernet I/O : I-8KE4-MTCP and I-8KE8-MTCP. If LAN2 is broken, it will switch to LAN1 automatically to continuously work. (This need LAN1 & @5 B & Ð g ' = D ' U f Y ' g Y h '] b ' 1042Y ' g U a Y ' = D ' X c		
FRnet I/O	Support max 7 pcs. I-8172W boards in slot 1 ~ 7 to connect to FRnet I/O modules like FR-2053, FR-2057 FR-32R, FR-32P. (FAQ-048). Each I-8172W board can link max. 256 DI plus 256 DO ch.		
Send Email	Support functions to send Email with one attached file via Ethernet port.		
Ebus	H c ' Y I W \ U b [Y ' X U h U ' V Y h k Y Y b ' = 7 D ' 8 5 G Ð g ' = (LAN2 Port only)		
SMS: Short Message Service	COM4 or COM5 can link to a GSM Modem to support SMS. User can request data/control the controller by cellular phone. The controller can also send data & U ' U f a g ' h c ' i g Y f Ð g ' W Y ' ' i ' U f ' d \ c b Y " Optional GSM Modem: GTM-201-RS232 (850/900/1800/1900 GSM/GPRS External Modem)		
MMICON/LCD	COM4 or COM5 supports ICP8 5 G Ð g ' A A = 7 C B "		
UDP Server & UDP Client : Exchange Message & Auto-Report	LAN1 or LAN2 support UDP Server and UDP Client protocol to send/receive message to / from PC/HMI or other devices. For example, to automatically report X U h U ' h c ' = b X i G c Z h Ð g ' F L H L ' X f] j Y f "		
TCP Client : Exchange Message & Auto-Report	LAN1 or LAN2 support TCP Client protocol to send / receive message to / from PC/HMI or other devices which support TCP server protocol.		

Models	XP -8047 -CE6	XP -8347 -CE6	XP -8747 -CE6
GPRS/SMS	Support the I-8212W (2G/3G) card to receive/send a short message or to dial up to link the Internet by GPRS connection to send an email or communicate with remote stations by using "Ftp Client" (FAQ-151) and "TCP Client" / "UDP Server" / "UDP Client" (FAQ -143).		
SQL Client	Support SQL Client function to write data to (or read data from) Microsoft SQL Server (2000 SP3, 2005, 2008).		
Hot-Swap and Redundant System	H \] g ` f Y X i b X U b h ` g m g h Y a ` \ U g ` g Y h i d ` h k c ` l and LAN2 ports always. One or more PC/HMI/SCADA can communicate with this redundant system via one of the two given active IP. So the PC/HMI/SCADA can access to the system easily without any notice about which PAC is currently active. Moreover, the new redundant system can integrate with the RU-87P4/87P8 Expansion Unit plus the I87K high-profile I/O cards to support the hot-swap application. If the I/O card is damaged, the maintenance person just takes one good-card with same model number to hot-swap the damaged one without stopping this redundant system.(FAQ -138 and FAQ-125)		
CAN/CANopen	COM1, 2, 4, 5 or COM6~COM33 to connect one I7530 (converter: RS-232 to CAN) to support CAN/CANopen devices and sensors. One PAC supports max.32 RS-232 ports to connect max.32 I7530. (*) (FAQ -086)		
CANopen Master	Support the I-8123W CANopen Master card to connect other CANopen slave devices. (FAQ -145)		
HART Solutions	Support I-87H17W modules in slot 1 to 7 to communicate with other HART devices.		
FTP Client	Support FTP client to upload files in the PAC to a remote FTP server on PC. (FAQ -151)		
Soft-GRAF HMI	Support the SoftGRAF HMI . User can use the Soft-GRAF Studio on the PC to design the HMI screen and then download it to the PAC to display the HMI on the PAC. (FAQ -146)		
Optional I/O Functions (Refer to ISaGRAF PAC I/O Selection Guide for I/O Module list)			
PWM Output	High Speed PWM Module	I-7088, I-8088W, I-87088W: 8-ch PWM outputs, software support 1 Hz ~ 100 kHz (non-continuous), duty: 0.1 ~ 99.9%	
	DO Module as PWM	88-ch max. 250 Hz max. For Off=2 & On=2 ms. Output square wave: Off: 2~32766 ms, On: 2 ~ 32766 ms. Optional DO Boards: I -8037W, 8041W, 8041AW, 8042W, 8050W, 8054W, 8055W, 8056W, 8057W, 8060W, 8063W, 8064W, 8068W, 8069W. (Relay Output boards cannot generate fast square wave)	
Counter Encoder Frequency	Parallel DI Counter	8 ch. max. for 1 controller. Counter val: 32 bit. 250 Hz max. Min. ON & OFF width must >2 ms. Optional DI boards: I -8040W, 8040PW, 8042W, 8046W, 8048W, 8050W, 8051W, 8052W, 8053W, 8053PW, 8054W, 8055W, 8058W, 8063W.	
	Serial DI Counter	Counter input: 100 Hz max. Counter value: 0 ~ 65535 (16 bit) Optional serial I-87K DI boards: I -87040W, 87046W, 87051W, 87052W, 87053W, 87053WA5, 87054W, 87055W, 87058W, 87059W, 87063W.	

Models		XP -8047 -CE6	XP -8347 -CE6	XP -8747 -CE6
	Remote DI Counter	All remote I-7K/I-87K DI modules support counters. 100 Hz max. value: 0 ~ 65535		
	High Speed Counter	I-87082W: 100 kHz max., 32-bit; I-8084W: 250 kHz max., 32-bit		
	Encoder	I-8093W: 3-axis Encoder Module, max. 1M Hz for quadrant input mode, max. 4 MHz for pulse/direction and cw/ccw input mode. (FAQ112) I-8084W: 250 kHz max., 4-ch encoder, pulse/direction or up/down or A/B phase (Quad. mode). Not support Encoder Z -index. (FAQ-100)		
	Frequency	I-87082W: 2-ch, 1 Hz ~ 100 kHz; I-87088W: 8-ch, 0.1 Hz ~ 500 kHz; I-8084W: 8-ch, 1 Hz ~ 250 kHz;		
Motion Control	XP-8347-CE6 / XP-8747-CE6 : Integrate with one or several I-8092F (2axis) or I-8094F/I8094 (4axis)			
<p>* Note: COM6 ~ COM33 are resided at the expansion boards if they are plugged on slot 1~7 of XP -8xx7 -CE6. XP -8347 -CE6/8747 -7 9 * Đ g ' 7 C A % '] g ' Z c f '] b h Y f b U-87K Wc modules in slots only.</p> <p>* ISaGRAF FAQ: http://www.icpdas.com/faq/isagraf.htm</p> <p>* Recommend to use NS -205/NS -208 Industrial Ethernet Switch.</p>				

Chapter 1 Typical Application

The website for the applications supporting list of all ISaGRAF PACs :
http://www.icpdas.com/products/PAC/common_file/application-notes.htm

1.1 Motion Control : Using I-8094F/8092F/8094

- ' XP-8xx7-CE6 plus I-8094F/8092F/8094 motion modules with daughter boards
- ' ISaGRAF + Soft-GRAF: User can achieve motion control, HMI design and I/O control within the ISaGRAF software.
- ' I-8094 is a 4-axis high speed motion control module.
- ' I-8094F (4-axis) and I-8092F (2-axis) are high speed motion control modules with FRnet master.
- ' More at www.icpdas.com> FAQ > Software > ISaGRAF Ver.3 (English) .
[FAQ-132](#).



1.2 Soft-GRAF HMI : Create A Colorful HMI

- ' Soft-GRAF Studio
 - Ø Simplify HMI screen editing (Mouse drag and drop)
 - Ø HMI without writing programming language
- ' Support various and colorful HMI objects:
 - Ø Page (Max. 200, support password security)
 - Ø Numeric (Input, input security, display)
 - Ø Text (Dynamic/static text display)
 - Ø Picture (Animated/static picture display)
 - Ø Moving Trace (1-axis or 2-axis)
 - Ø Bar-meter (Vertical/horizontal dynamic display)
 - Ø Button displayed as text
 - Ø Button displayed as picture
 - Ø Built-in various objects
- ' Multi-language: English, Traditional Chinese, Simplify Chinese, Russian
- ' HMI behave smoothly
- ' More at: Chapter 2.5 & FAQ www.icpdas.com > FAQ > Software > ISaGRAF Ver.3 . FAQ-146

Running HMI and Control Logic in the Same PAC

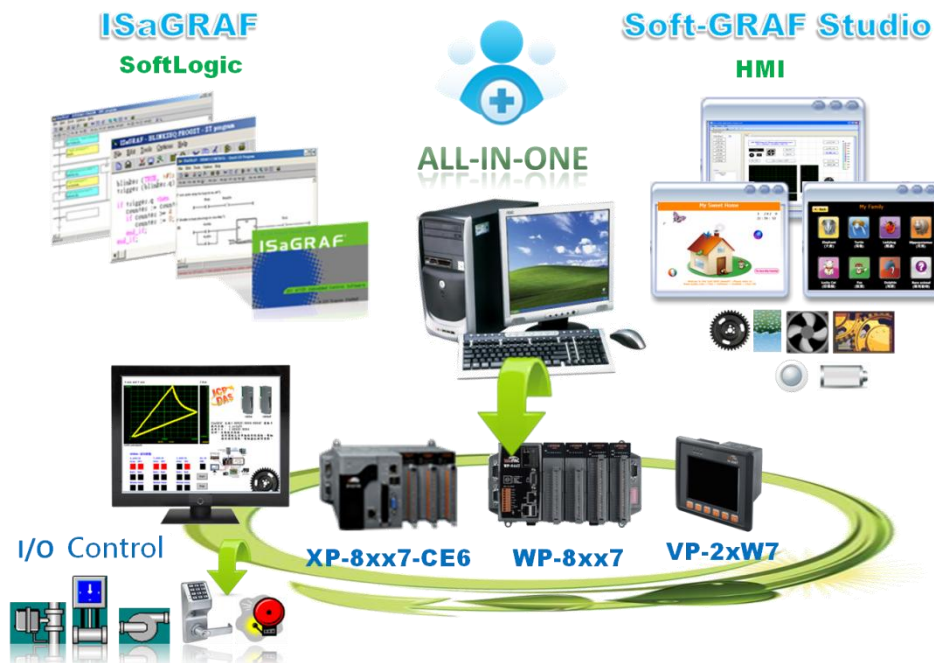

1.3 eLogger HMI Application

- ICP DAS eLogger is an easy and useful HMI development tool which helps user to create user-friendly pictures and control items.
- More at: www.icpdas.com > FAQ > Software > ISaGRAF > FAQ-115.

ISaGRAF
Software Development Tool

- Simulate without PAC
- Debug / Control / Monitor On-Line
- Six Open SoftLogic Languages (LD, ST, ...)

eLogger
HMI Development Tool

- Free HMI Toolkit
- Easy & Useful HMI

ICP DAS

WP-8x47 / 8x37 XP-8xx7-CE6 VP-25W7 / 23W7

1.4 Connect the Smart Power Meter PM-2133/2134

- ' ISaGRAF PAC support standard Modbus protocol, support multiple RS-485 ports to connect to multiple PM-213x Smart meters.
- ' For the power measurement control systems in small/medium sized stores, buildings and factories with electric equipments.
- ' PM-213x smart meter with "Wh" pulse output is useful in the systems needing to connect the meter tester.
- ' PM-213x smart meter with wired clip-on CT is easily wiring for on-line installation, suitable for the uninterruptible power systems.
- ' PM-213x is a series of 3 Phase/4 Loops 1 Phase Compact Smart Meter with true RMS energy and power parameters measurement in compact size. The ISaGRAF PACs combining with PM-213x can apply to various control/monitor systems about intelligent electric power measurement.
- ' More at www.icpdas.com> FAQ > Software > ISaGRAF Ver.3 (English) - 129.



1.5 Redundant Communication System

- Please refer to www.icpdas.com > FAQ > Software > ISaGRAF > FAQ-119 for more information about RS-485 and Ethernet redundant communication mechanism and applications.

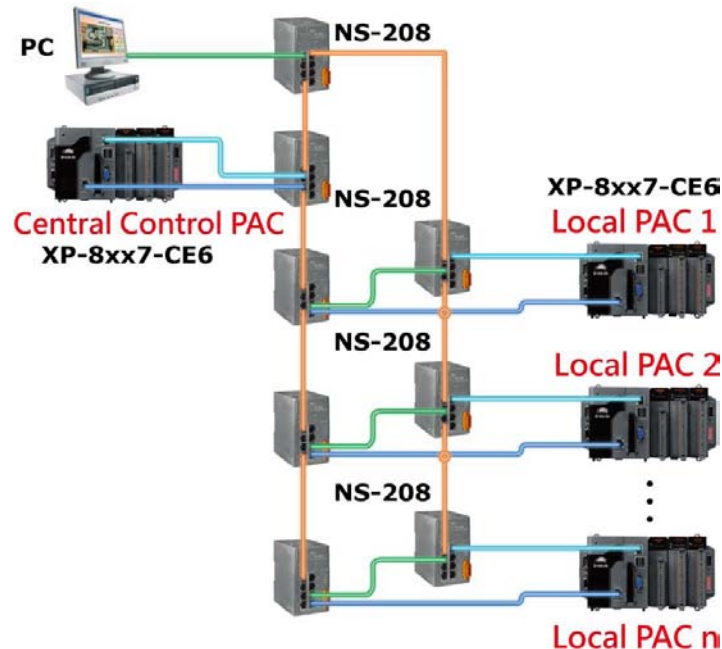

1.6 Redundant System - Ethernet I/O

- If one Ethernet cable is broken or damaged, the other one will still handle the Ethernet I/O and exchange data with the other redundant controller.
- The scan of Ethernet I/O is much faster than that of RS-485 I-7000/I-87K I/O.
- More at www.icpdas.com > FAQ > Software > ISaGRAF Ver.3 (English) - 125

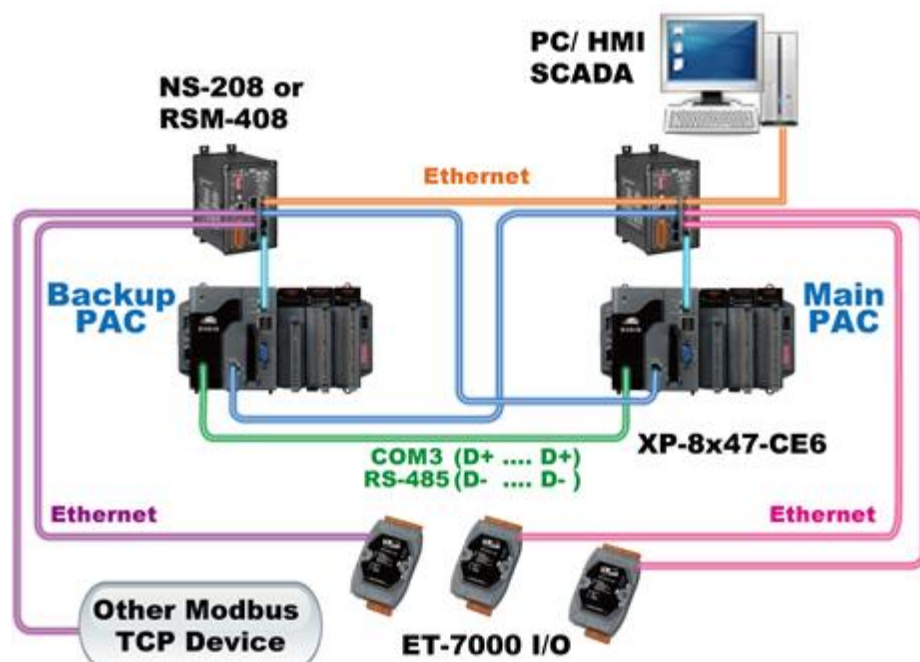

1.7 Redundant System – Hot-Swap RS-485 I/O

- If one Ethernet cable of PAC is broken or damaged, the other one will still work. If one controller is dead, the other one will take over the control of the RS-485 I/O.
- PC/HMI can connect to this redundant system by one or two active IP.
- More at www.icpdas.com > FAQ > Software > ISaGRAF Ver.3 - 093

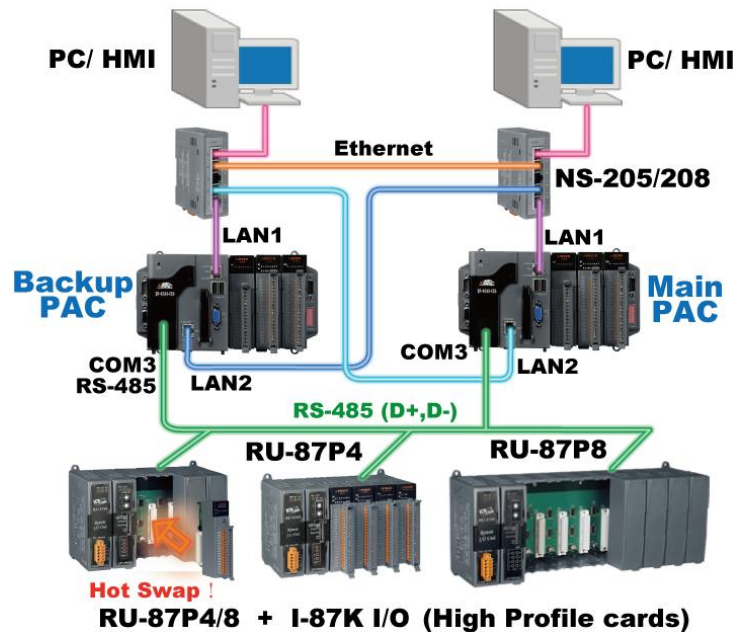

1.8 Redundant System – with iDCS-8000

- Dual PACs, dual Ethernet ports redundant system
- PC/HMI can just connect one IP address to link to the redundant system. If the active PAC is damaged, it will take about 0.5 seconds to switch to the other PAC.
- More at www.icpdas.com > FAQ > Software > ISaGRAF Ver.3 . 125

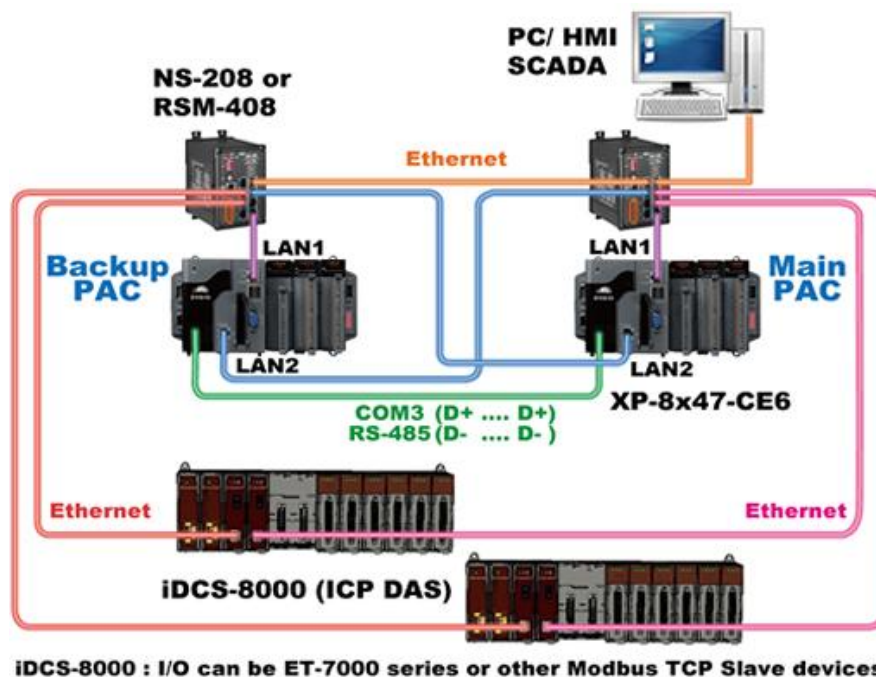

1.9 Modbus Master: TCP/IP

- Each XP-8xx7-CE6, WP-8xx7 or VP-25W7/23W7 supports to link to max. 100 Modbus TCP/IP slave devices.
- Support various Standard Modbus TCP/IP Slave devices.
- More at: www.icpdas.com > FAQ > Software > ISaGRAF Ver.3 (English) > 113

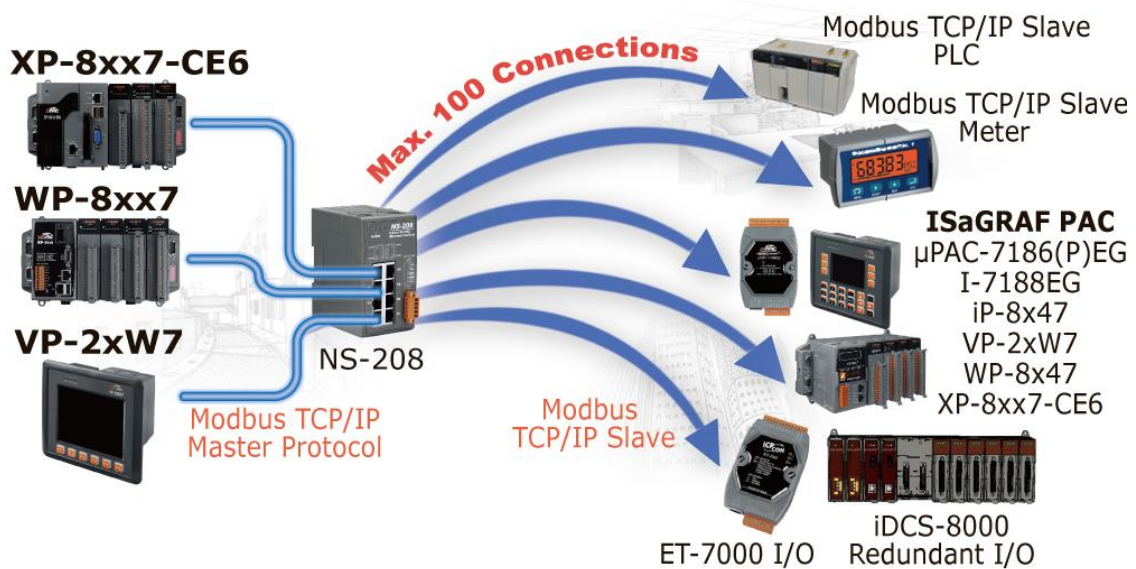

1.10 Modbus Master: RTU, ASCII, RS-232/485/422

- Support up to 33 ports:
COM1~COM5 (only XP-8047-CE6 can use COM1 as Modbus Master)
COM6~COM33 (if I-8112iW/ 14W/ 14iW/ 42iW/ 44iW in Slot1~7)
- Note: XP-8347-CE6 / 8747-Ô Ò Î q • Á Ô U T F Á ã • communication } c ^ ! } a with I-87K modules in slots only.
- Can link to Modbus PLC or M-7000 I/O or Modbus devices (Power meter, temperature controller, inverter etc.)

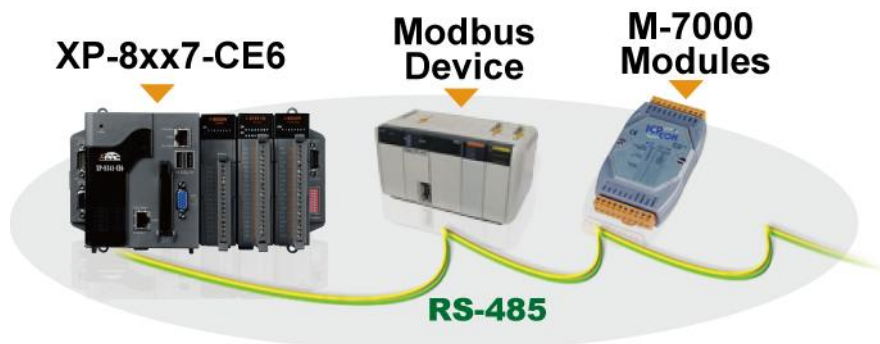

1.11 Modbus Slave: RTU/TCP

- ' Modbus RTU Slave (RS-232/485/422): max. 9 ports
- ' Modbus TCP/IP Slave : max. 64 connections



1.12 Communicate With Other TCP/IP Server or UDP Client/Server Devices

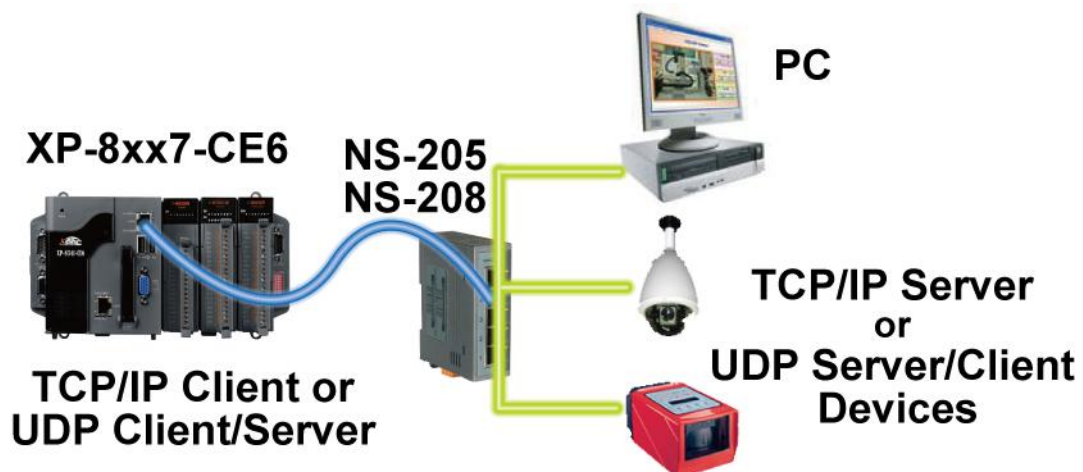

1.13 Multiple Web HMI Monitor & Control Everywhere!

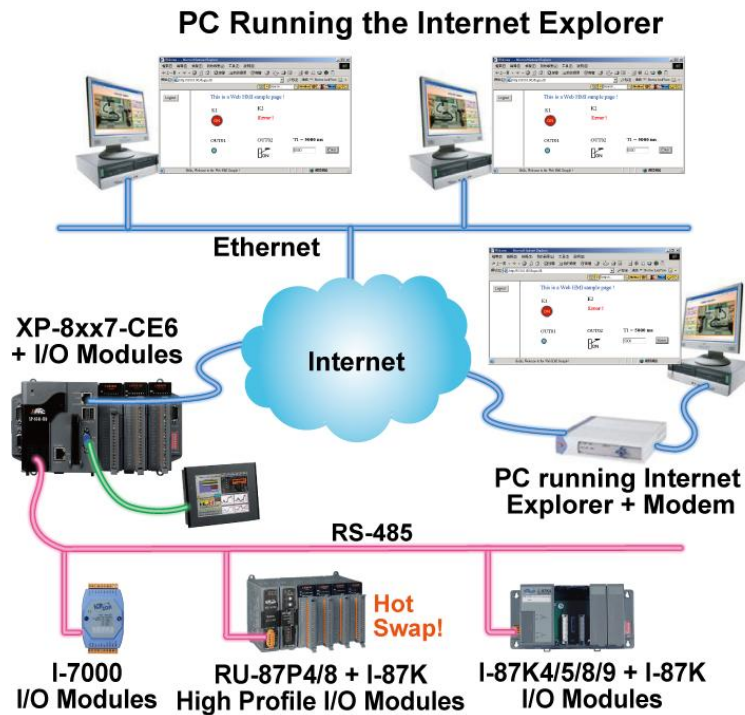

1.14 Send Email With or Without One Attached File

More at www.icpdas.com > FAQ > Software > ISaGRAF Ver.3 (English) - 067

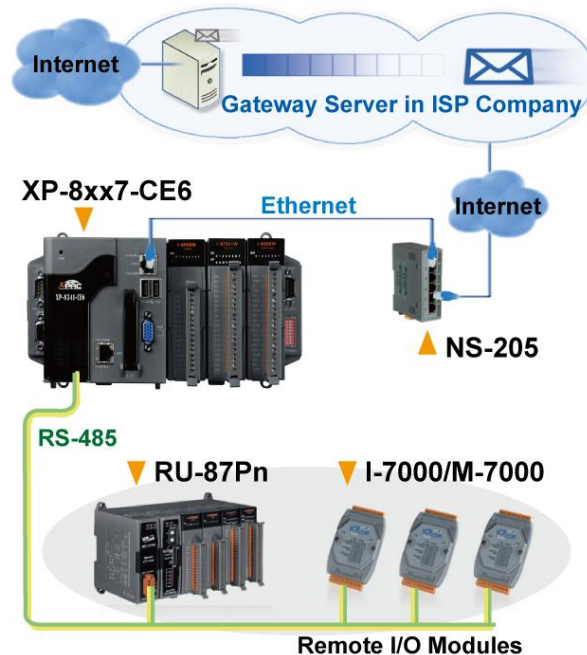

1.15 Data-Recorder & Data-Logger

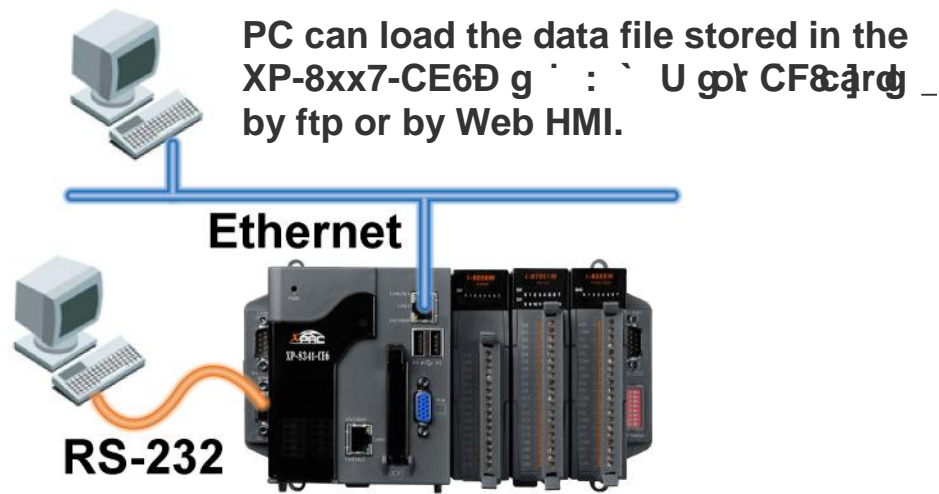

1.16 Remote I/O Application

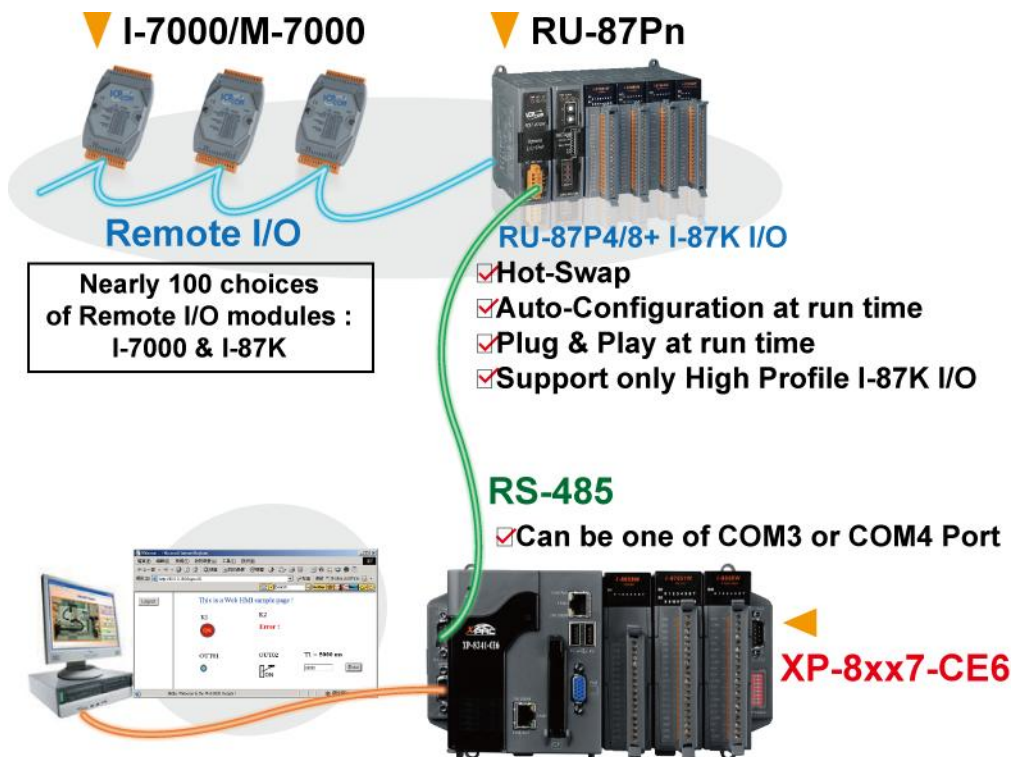

1.17 SMS: Short Message Service

- Short message can be sent in multiple language format (like Chinese, English... others)
- More at www.icpdas.com > FAQ > Software > ISaGRAF Ver.3 (English) - 111

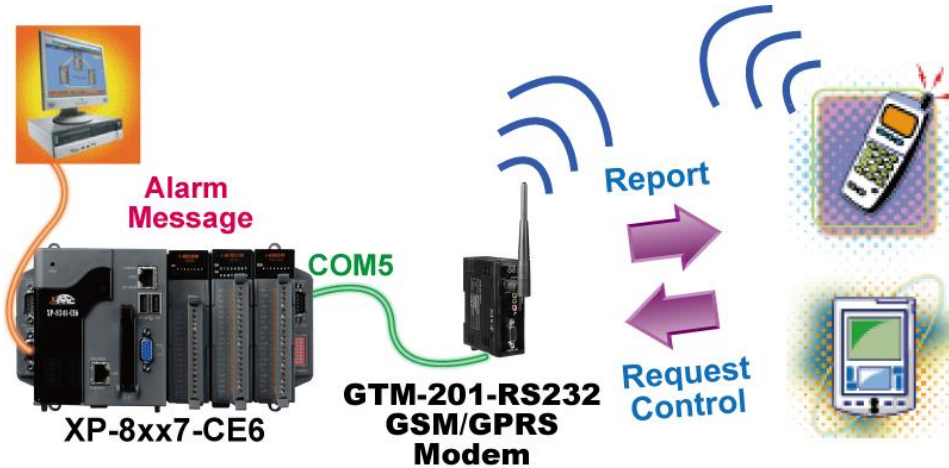

1.18 Auto-report Acquisition & Control Data

- XP-8xx7-CE6 can use UDP IP Client to auto-report acquisition data & control data to local or remote internet PC/Server.
- Advantage: Every PAC in the different location doesn't need a fixed Internet IP
- More at www.icpdas.com > FAQ > Software > ISaGRAF Ver.3 (English) - 065

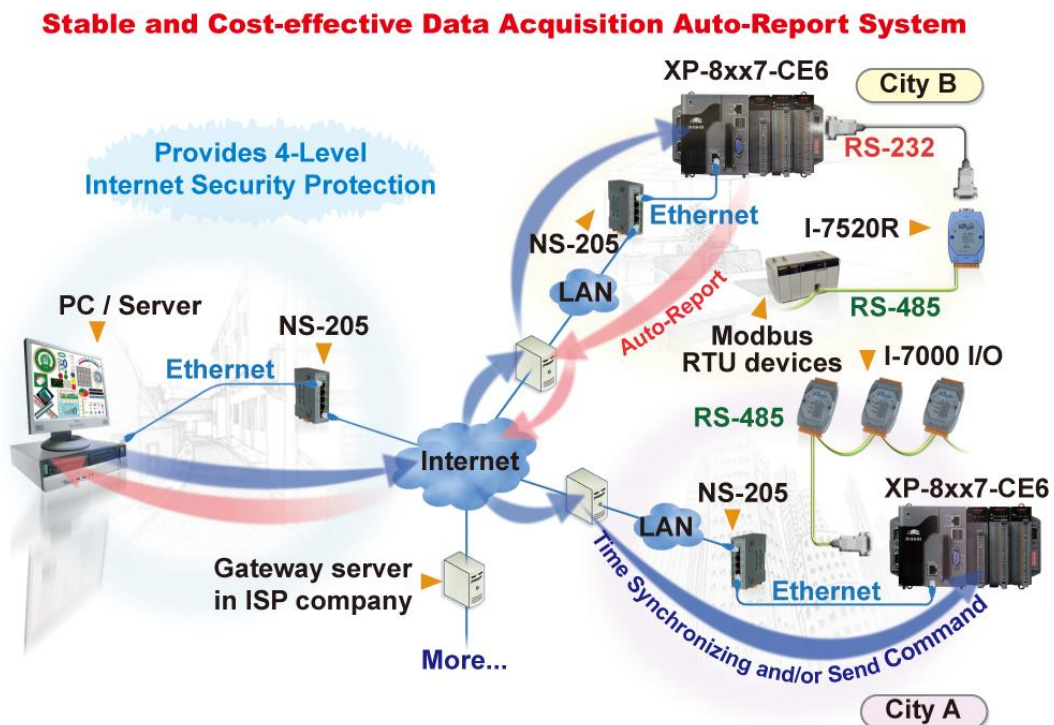

1.19 Stress Monitoring Application of Constructions

- ' ICP DAS releases effective "VW Sensor" (Vibration Wire solution) and "Carlson Strain Gauge Inputs" solution . It's useful for measuring the stress of constructions like building, bridge, dam, etc.
- ' Each ISaGRAF PAC (as FAQ-091) supports the I-87089 (the VW master card) plus the DN-1618UB (daughter board) to achieve the "VW Sensor" application.
- ' Each XP-8xx7-CE6, WP-8xx7 or VP-25W7/23W7 supports the I-87113DW module (the master card of Carlson Strain Gauge Inputs) plus the DN-1619 (DN-1618U-Test1) (daughter board) to achieve the "Carlson Strain Gauge Inputs" application.
- ' Please click www.icpdas.com > FAQ > Software > ISaGRAF Ver.3 (English) - 091, 128 for more information.

