Getting Started : VP-25W7 , VP-23W7

The VP-2xW7 is the abbreviation of the VP-25W7 and VP-23W7.
The VP-2xW6 is the abbreviation of the VP-25W6 and VP-23W6.

Important Notice:

1. **VP-25W7, VP-23W7, VP-25W6 and VP-23W6 support only High profile I-8K and I-87K I/O cards in its slot 0 to 2. Please refer to VP-25W7/23W7 CD-ROM:**
`\napdos\isagraf\vp-25w7-23w7\english-manu\Í j -25w7-23w7-X U h U g \ Y Y h " d X Z Í`
2. Please always set a **fixed IP** address to the VP-2xW7, VP-2xW6, VH-2xW7 and VH-2xW6. (No DHCP). Recommend to use the NS-205 / NS-208 Industrial Ethernet Switch for them.

Legal Liability

ICP DAS CO., LTD. assumes no liability for any and all damages that may be incurred by the user as a consequence of this product. ICP DAS CO., LTD. reserves the right to change this manual at any time without notice.

ICP DAS CO., LTD. constantly strives to provide our customers with the most reliable and accurate information possible regarding our products. However, ICP DAS CO., LTD. assumes no responsibility for its use, or for any infringements of patents or other rights of third parties resulting from its use.

Trademark & Copyright Notice

The names of products and name of company are used for identification purposes only, and are the registered trademarks of their respective owners or companies.

Development Software

Two options:

- ISaGRAF: Ver. 3.4x (or Ver. 3.5x), IEC61131-3 standard. LD, ST, FBD, SFC, IL & FC or
- Non-ISaGRAF: Microsoft EVC++4.0 or VS.NET 2008/2005/2003 (VB.net, C#.net)

Reference Guide

- ISaGRAF English Use: `q • Á T æ} ~ æ| K Á Á`
VP-25W7/23W7 CD: `\napdos\isagraf\vp-25w7-23w7\english-manu\`
"user_manual_i_8xx7.pdf" and "user_manual_i_8xx7_appendix.pdf"
- ISaGRAF :
VP-25W7/23W7 CD: `\napdos\isagraf\vp-25w7-23w7\chinese-manu\`
"%o& @ã } ^ • ^ ´ ~ • ^ | ´ { æ} ä É%o& @ã } ¢ ¢ Ì È] á Á Á (ææ) ~ æ| ´ ã ´ ì q
- More from the Internet: <http://www.icpdas.com/products/PAC/i-8000/isagraf.htm>

Technical Service

service@icpdas.com. FAQ : <http://www.icpdas.com/faq/isagraf.htm>

Writer: Chun Tsai, Last Editor: Eva Li
Copyright Jul. 2009, by ICP DAS CO., LTD. All Rights Reserved.

Table of Contents

Getting Started : VP-25W7 , VP-23W7	1
Important Notice:	1
Legal Liability	1
Trademark & Copyright Notice	1
Development Software	1
Reference Guide	1
Technical Service	1
Table of Contents	2
Reference Guide	5
I/O Modules Selection Guide for VP-25W7 / VP-23W7 / VP-25W6 / VP-23W6	6
Performance Comparison Table of ISaGRAF PACs	11
Specifications: VP-25W7 / VP-23W7	12
Chapter 1 Typical Application	1-1
1.1 Soft-GRAF HMI Application: Colorful HMI	1-1
1.2 eLogger HMI Application	1-2
1.3 Redundant Communication System	1-3
1.4 New Hot-Swap and Redundant System	1-3
1.5 Modbus Master: TCP/IP	1-4
1.6 Modbus Master: RTU, ASCII, RS-232/485/422	1-4
1.7 Modbus Slave: RTU/TCP	1-5
1.8 Communicate With Other TCP/IP Server or UDP Client/Server Devices	1-5
1.9 Multiple Web HMI . Monitor & Control Everywhere!	1-6
1.10 Send Email with One Attached File	1-6
1.11 Data-Recorder & Data-Logger	1-7
1.12 Remote I/O Application	1-7
1.13 SMS: Short Message Service	1-8
1.14 Auto-report Acquisition & Control Data	1-8
1.15 Motion Control.....	1-9
1.16 Stress Monitoring Application of Constructions	1-9
1.17 Fast FRnet Remote I/O	1-10
1.18 Integrate with CAN/CANopen Devices & Sensors	1-10
1.19 VIP Communication Security.....	1-11
1.20 ISaGRAF PAC Connects the Smart Power Meter.....	1-11
1.21 ZigBee Wireless Solution	1-12
1.22 GPS Application: ISaGRAF PAC Plus I-87211W or GPS-721	1-13
1.23 Data Exchange: Ebus.....	1-14
1.24 Detect Hot-Swap I-87K (High Profile) I/O Status	1-14
1.25 Database Application	1-15
1.26 HART Solutions.....	1-16
Chapter 2 Software Installation And Working Soft-GRAF HMI with ISaGRAF	2-1
2.1 Step 1 - Installing The ISaGRAF Software	2-1
2.1.1 The Hardware Protection Device (Dongle & USB Key-Pro)	2-2
2.1.2 Important Notice For Window 2000 Users.....	2-3
2.1.3 Important Notice for Window NT Users	2-4
2.1.4 Important Notice for Windows Vista or Windows 7 (32-bit) Users	2-4
2.1.5 Important Notice for Windows 7 (64-bit) Users.....	2-6

2.1.6	Important Setting for Using Variable Arrays	2-6
2.2	Step 2 - Installing The ICP DAS Utilities For ISaGRAF	2-7
2.3	Step 3 - Installing The Web Page Editor	2-8
2.4	Working eLogger HMI with ISaGRAF SoftLogic	2-8
2.5	Working Soft-GRAF HMI with ISaGRAF SoftLogic	2-9
Chapter 3	Setting Up A Web HMI Demo.....	3-11
3.1	Web Demo List.....	3-11
3.2	Steps To Set Up A Web HMI Demo	3-12
3.2.1	Step 1 - Setup The Hardware.....	3-12
3.2.2	Step 2 - Setting The Web Options.....	3-12
3.2.3	Step 3 - Download ISaGRAF Project	3-13
3.2.4	Step 4 - Download Web Pages To The ViewPAC.....	3-16
3.2.5	Step 5 - Show Time.....	3-16
Chapter 4	Programming A Web HMI Example.....	4-1
4.1	Writing A Simple ISaGRAF Program.....	4-1
4.1.1	Open ISaGRAF-Project Management.....	4-2
4.1.2	Creating An ISaGRAØ Á W• ^ q •.Á.Ö.!.[.~.].....	4-3
4.1.3	Creating A New ISaGRAF Project.....	4-3
4.1.4	Declaring The ISaGRAF Project Variables.....	4-4
4.1.5	Assign Modbus Network Address No to Variables	4-7
4.1.6	Create The LD - "LD1" Program.....	4-9
4.1.7	Edit The "LD1" Program	4-10
4.1.8	Connecting The I/O	4-14
4.2	Compiling & Simulating The Example Project	4-16
4.2.1	Compiling Error Result In Different ISaGRAF Version	4-16
4.3	Download & Debug The Example Project	4-20
4.4	Design The Web Page	4-24
4.4.1	Step 1 . Copy The Sample Web HMI pages.....	4-24
4.4.2	Step 2 . Building The Main.htm	4-25
4.4.3	Step 3 . Adding Control Code To The Main.htm.....	4-30
4.4.4	Step 4 . Download Web HMI Pages To The Controller	4-35
Chapter 5	Web HMI Basics	5-1
5.1	Basic Files For The Web HMI	5-1
5.2	Login.htm	5-2
5.3	menu.htm	5-3
5.4	main.htm	5-5
5.4.1	A Simple Main.htm Example	5-5
5.4.2	More About The refresh_data() Function And Dynamic Data.....	5-7
5.4.3	Post Data To The Controller.....	5-13
5.5	Multi-Pages	5-17
5.5.1	Level 2 And Level 3 Page	5-17
5.5.2	Switch One Page To One Another Page.....	5-18
5.6	Web Security.....	5-19
Chapter 6	VB.NET 2008 Program Running In ViewPAC Access To ISaGRAF Variables ..	6-1
6.1	Create a New Project	6-1
6.2	Add Project Reference for an Application.....	6-2
6.3	Compiling an Application Program	6-4
6.4	QuickerNET.DLL	6-5
6.4.1	Digital R/W Functions.....	6-5
6.4.2	Analog R/W Functions.....	6-7
Chapter 7	EVC++ Program Running In ViewPAC Access To ISaGRAF Variables	7-1

Chapter 8	InduSoft Project Running In ViewPAC Access To ISaGRAF Variables	8-1
Chapter 9	Example Program & FAQ.....	9-1
9.1	Get On-Line help	9-1
9.2	Installing The ISaGRAF Programming Examples	9-4
9.3	Frequently Asked Questions	9-11
Chapter 10	C# .NET 2008 Program Running In ViewPAC Access To ISaGRAF Variables.....	10-1
10.1	Create a New Project	10-1
10.2	Add Project Reference for an Application.....	10-2
10.3	Compiling an Application Program	10-5
10.4	QuickerNET.DLL	10-5
10.4.1	Digital R/W Functions.....	10-6
10.4.2	Analog R/W Functions.....	10-7
Appendix A	Hardware System & Setting	1
A.1	Applying Correct Power Supply.....	1
A.2	Modify The NET-ID & Modbus RTU Port Setting	2
A.3	Setting The IP Address For The ViewPAC	3
A.4	Connecting Your PC To The VP-2xW7 Ethernet Port	4
A.5	Pin Assignment of COM2 , COM3 and Multi-Clients Connection to The VP-25W7 / VP-23W7	5
A.6	Connecting PC To VP-2xW7 's COM2 or COM3.....	6
A.7	Deleting the ISaGRAF Project From The ViewPAC	7
A.8	Linking I-7000 and I-87K Modules For Remote I/O	8
A.9	Linking To An HMI Interface Device	9
A.10	Linking To Other Modbus Devices	10
A.11	Recalibrate The Touch Screen Of VP-25W7.....	11
Appendix B	15
Appendix C	Dimension.....	17
Appendix D	Enable The Second Ethernet Port Of The VP-25W7 / VP-23W7 / VP-25W6 / VP-23W6	18
Appendix E	Using Expansion RS-232/485/422	20
Appendix F	24
Appendix G	Setup More Modbus RTU Salve Ports	25
Appendix H	Compiling Error Result In Different ISaGRAF Version.....	26
Appendix I	Why my PC running ISaGRAF can not connect the ISaGRAF PAC correctly ?	27
Appendix J	Control Buttons On The Front Panel.....	28
Appendix K	Enable the Screen Saver of ViewPAC	29

Reference Guide

= G U ; F 5 : ' 9 b [`] g \ ' i g Y f Ð g ' A U b i U ` . ' ' .

VP-25W7/23W7 CD: \napdos\isagraf\vp-25w7-23w7\english-manu\
"user_manual_i_8xx7.pdf" and "user_manual_i_8xx7_appendix.pdf"
http://www.icpdas.com/products/PAC/i-8000/getting_started_manual.htm

ISaGRAF :

VP-25W7/23W7 CD: \napdos\isagraf\vp-25w7-23w7\chinese-manu\
"chinese_user_manual_i_8xx7.pdf" and "chinese_user_manual_i_8xx7_appendix.pdf"
http://www.icpdas.com/products/PAC/i-8000/getting_started_manual.htm

Industrial Ethernet Switch : NS-205/NS-208

http://www.icpdas.com/products/Switch/switch_list.htm



Model: NS-205



Model: NS-208

Power Supply :

http://www.icpdas.com/products/Accessories/power_supply/power_list.htm

DP-660 : 24 V / 2.5 A , 5 V / 0.5 A power supply (DIN-Rail mounting)

DP-665 : 24 V / 2.5 A , 5 V / 0.5 A power supply

DP-1200 : 24 V / 5 A power supply



Model: DP-660



Model: DP-1200



Model: DP-665

FAQ:

www.icpdas.com > FAQ > Software > ISaGRAF for Frequently Asked Questions.
<http://www.icpdas.com/faq/isagraf.htm>

I/O Modules Selection Guide for VP-25W7 / VP-23W7 / VP-25W6 / VP-23W6

The VP-25W7 / VP-23W7 / VP-25W6 / VP-23W6 support only the I-8K / I-87K High Profile I/O modules and RS-485 / FRnet remote I/O modules listed in the [ISaGRAF Data Sheet](#) . Please refer to the list in the next page or follow the below steps to get the newest list.

1. www.icpdas.com

The screenshot shows the ICP DAS website homepage. A red callout box highlights the URL '1. www.icpdas.com' in the browser's address bar. The website features a navigation menu with options like Home, About Company, Products, Download, Distributors, Partners, Training, Activity, and Catalog. A search bar is located in the top right corner. The main content area displays the 'ViewPAC Family' as 'The All-in-One Control Unit' with features like Touch Screen, Programmable Keypads, and Optional Operation System. Below this, there are sections for 'PPDS-700 Series' (Programmable Device Server, Intelligent Serial-Ethernet Gateway, Power over Ethernet, Flexible COM Ports, Built-in Watchdogs and DI/DO, Virtual COM technology) and a list of product models including MD-2055PSE, G-4500, I-8088W, WP-8446, PET-7060, and PPDS-700. On the right side, there are categories like Industrial (Fiber Switch, Ethernet Switch, Ethernet Real-time-ing Switch), VXC Card, Multiport Serial Card, Programmable Serial-to-Ethernet Device Server, PDS, PET-7000, PoE Ethernet I/O, and ET-7000 Ethernet I/O.

3. Data Sheet

The screenshot shows the ISaGRAF Data Sheet page on the ICP DAS website. A red callout box highlights the '3. Data Sheet' link in the right-hand navigation menu. The main content area features a central diagram of the 'ISaGRAF PAC' system, which is a globe-like structure with various components and protocols connected to it. The components include WinPAC, IPAC, ViewPAC, HMI & SCADA Software, Modbus RTU Slave Protocol, DCON Protocol, Modbus Devices, EKAN, M-7000 Remote I/O, I-7000 Remote I/O, and RU-87Pn/I-87Kn & I-87K Remote I/O. The protocols shown are Ethernet SOI/panel, RS-232, RS-485, and SMS Short Message service. The diagram also shows connections to WinPAC, IPAC, and ViewPAC. The left-hand navigation menu includes options for Language (中文), Topics (What is ISaGRAF, Hot Features, Ordering Information, Selection Guide, Related Products), and ISaGRAF PACs (XP-8x47-CE6, WP-8x37/8x47, VP-25W7/23W7, VP-2117, IP-8x47, I-8x47 & I-8x37-80, μPAC-7186EG, I-7188EG, I-7188XG, Comparison Table (All)).

High Speed Local I/O Modules: Parallel Bus

I-8K High Profile Modules: More at www.icpdas.com > Products > PAC - 8K & 87K I/O Modules

I-8K Analog I/O Modules	
I-8014W	16-bit 250K sampling rate 8/16-ch. analog input module (The scan rate cannot reach 250K when using in the ISaGRAF PAC)
I-8017HW	8-ch. Differential or 16-ch. Single-ended, 14-bit, High Speed Analog Input Module. (current input require external 125 K resistor) (The scan rate cannot reach 100K when using in the ISaGRAF PAC)
I-8024W	4-ch. Isolated Analog Output Module (+/-10 V, 0 ~ +20 mA)
I-8K Digital I/O Modules	
I-8037W	16-ch. Isolated Open Collector Output Module
I-8040W	32-ch. Isolated Digital Input Module
I-8040PW	32-ch. Isolated Digital Input with Low Pass Filter Module
I-8041W	32-ch. Isolated Open Collector Digital Output Module (Sink)
I-8041AW	32-ch. Isolated Open Collector Digital Output Module (Source)
I-8042W	16-ch. Isolated Digital Input & 16-ch. Isolated Open Collector Digital Output Module
I-8046W	16-ch. Isolated Digital Input Module
I-8050W	16-ch. Universal Digital I/O Module
I-8051W	16-ch. Non-isolated Digital Input Module
I-8052W	8-ch. Differential Isolated Digital Input Module
I-8053W	16-ch. Isolated Digital Input Module
I-8053PW	16-ch. Isolated Digital Input with Low Pass Filter Module
I-8054W	8-ch. Isolated Digital Input Module & 8-ch. Isolated Open Collector Digital Output Module
I-8055W	Non-isolated 8-ch. Digital Logic Input Module & 8-ch. Open Collector Digital Output Module
I-8056W	16-ch. Non-isolated Open Collector Output Module
I-8057W	16-ch. Isolated Open Collector Output Module
I-8058W	8-ch. Differential Isolated Digital Input Module, Max. AC/DC Input : 250V
I-8060W	6-ch. Relay Output Module, AC: 0.6 A @ 125 V , 0.3 A @ 250 V; DC: 2 A @ 30 V
I-8063W	4-ch. Differential Isolated digital input & 4-ch. Relay output module, AC : 0.6 A @ 125 V ; 0.3 A @ 250 V
I-8064W	8-ch. Power Relay Output Module, AC: 5 A @ 250 V, DC: 5 A @ 30 V
I-8068W	4-ch. Form-A, 5 A @ 250 V _{AC} /28 V _{DC} & 4-ch. Form-C, 5 A (NO) /3 A (NC) @ 277 V _{AC} /30 V _{DC} Relay Output Module
I-8069W	8-ch. PhotoMOS Relay Output Module, Max. AC/DC: 1 A @ 60 V
I-8K Counter/Frequency Modules	
I-8084W	4-ch. Encoder, can be dir/pulse, or up/down or A/B phase (Quad. mode), Not support Encoder Z-index
I-8088W	8-ch. PWM Output and 8-ch. isolated DI Module, software support 1 Hz ~ 100 kHz (non-continuous).
I-8K Motion Modules	
I-8093W	3-axis Encoder Module, max. 1M Hz for quadrant input mode, max. 4M Hz for pulse/direction and cw/ccw input model

I-8090W	3-axis Encoder Module
I-8091W	2-axis Stepping/Servo Motor Control Card without encoder input
I-8092F	High Speed 2-axis Motion Control Module, with FRnet Master (For XP-8xx7-CE6 only)
I-8094	High Speed 4-axis Motion Control Module (For XP-8xx7-CE6 only)
I-8094F	High Speed 4-axis Motion Control Module, with FRnet Master (For XP-8xx7-CE6 only)
I-8K Co mmunication Modules	
I-8112iW	2-ch. Isolated RS-232 Expansion Module
I-8114W	4-ch. non-isolated RS-232 Expansion Module
I-8114iW	4-ch. Isolated RS-232 Expansion Module
I-8142iW	2-ch. Isolated RS-422/485 Expansion Module
I-8144iW	4-ch. Isolated RS-422/485 Expansion Module
I-8172W	2-port FRnet Module
I-8K CAN Bus Modules	
I-8123W	1 Port High Performance CANopen Master Module

RS-485 Remote I/O Modules: Serial Interface; HOT-SWAP

I-87K High Profile Modules: More at www.icpdas.com > Products > PAC - 8K & 87K I/O Modules

I-87K Analog I/O Modules	
I-87005W	8-ch. Thermistor input and 8-ch. digital output module
I-87013W	4-ch., 16-bit, 10 Hz (Total), 2/3/4 Wire RTD Input Module with Open Wire Detection
I-87015W	7-ch., 16-bit, 12 Hz (Total), RTD Input Module with Open Wire Detection (for short sensor distance)
I-87015PW	7-ch. RTD Input Module with 3-wire RTD lead resistance elimination and with Open Wire Detection (for long sensor distance)
I-87017RW	8-ch. Differential , 16/12-bit, 10/60 Hz (Total) Analog Input Module with 240 V _{rms} Over Voltage Protection, Range of -20 ~ +20 mA Requires Optional
I-87017RCW	8-ch. Differential , 16/12-bit, 10/60 Hz(Total) Current Input Module
I-87017W	8-ch. Analog Input Module
I-87017W-A5	8-ch. High Voltage Input Module
I-87017DW	8-ch. Analog Input Module (Gray Cover) (RoHS)
I-87017ZW	10/20-ch. Analog Input Module with High Voltage Protection (RoHS)
I-87018PW	8-ch. Thermocouple Input Module (Gray Cover) (RoHS)
I-87018RW	8-ch. Thermocouple Input Module. Recommend to use the better I-87018Z.
I-87018W	8-ch. Thermocouple Input Module. Recommend to use the better I-87018Z.
I-87018ZW	10-ch. Differential , 16-bit, 10 Hz (Total), Thermocouple Input Module with 240 V _{rms} Over Voltage Protection, Open Wire Detection, Range of +/-20 mA, 0~20 mA, 4~20 mA requires Optional External 125 Resistor
I-87019PW	8-ch. Universal Analog Input Module (RoHS) (With a CN-1824 Daughter Board)
I-87019RW	8-ch. Diff. , 16-bit, 8 Hz (Total), Universal Analog Input Module with 240 V _{rms} Over Voltage Protection, Open Wire Detection (V, mA, Thermocouple; Range of -20 ~ +20 mA need to set Jumper on board)
I-87019ZW	10-ch. Universal Analog Input Module (Gray Cover) (RoHS), Includes the

	I-87019ZW Module and a DB-1820 Daughter Board
I-87024CW	4-ch. 12-bit channel to channel isolated current output module with open-wire detection
I-87024DW	4-ch. 14-bit analog output module
I-87024RW	4-ch. 14-bit analog output module
I-87024W	4-ch. 14-bit analog output module (0 ~ +5 V, +/-5 V, 0 ~ +10 V, +/-10 V, 0 ~ +20 mA, +4 ~ +20 mA)
I-87028CW	8-ch. 12-bit current output module
I-87H17W	8-ch. analog input module and HART master module.
I-87K Multifunction I/O Modules	
I-87026PW	6-ch. Analog Input, 2-ch. Analog Output, 2-ch. Digital Input and 2-ch. Digital Output Module (RoHS)
I-87K Digital I/O Modules	
I-87037W	16-ch. source type Isolated Digital Output Module(RoHS)
I-87040W	32-ch. Isolated Digital Input Module
I-87040PW	32-ch. Isolated Digital Input Module with 16-bit Counters (RoHS)
I-87041W	32-ch. Sink Type Open Collector Isolated Digital Output Module
I-87046W	16-ch. Non-Isolated Digital Input Module for Long Distance Measurement
I-87051W	16-ch. Non-Isolated Digital Input Module
I-87052W	8-ch. Differential , Isolated Digital Input Module
I-87053PW	16-ch. Isolated Digital Input Module with 16-bit Counters
I-87053W	16-ch. Isolated Digital Input Module
I-87053W-A5	16-ch. 68 ~ 150 V _{DC} Isolated Digital Input Module
I-87053W-AC1	16-ch. AC Isolated Digital Input Module with 16-bit Counters
I-87053W-E5	16-channel 68-150 V _{DC} Isolated Digital Input Module with 16-bit Counters
I-87054W	Isolated 8-ch. DI and 8-ch. Open Collector DO Module
I-87055W	Non-Isolated 8-ch. DI and 8-ch. Open Collector DO Module
I-87057W	16-ch. Open Collector Isolated Digital Output Module
I-87057PW	16-ch. Open Collector Isolated Digital Output Module
I-87058W	8-ch. 80~250 V _{AC} Isolated Digital Input Module
I-87059W	8-ch. Differential 10-80 V _{AC} Isolated Digital Input Module
I-87061W	16-ch. Relay Output Module (RoHS)
I-87063W	4-ch. Differential Isolated Digital Input and 4-ch. Relay Output Module 5 A (NO) / 3 A(NC) @ 5 ~ 24 V _{DC} ; 5 A(NO) / 3 A(NC) @ 0 ~ 250 V _{AC}
I-87064W	8-ch. Relay Output Module, 5 A (47~63 Hz) @ 0~ 250 V _{AC} ; 5 A @ 0~ 30 V _{DC}
I-87065W	8-ch. AC SSR Output Module, AC: 1.0 A _{rms} @ 24 ~ 265 V _{rms}
I-87066W	8-ch. DC SSR Output Module , DC: 1.0 A _{rms} @ 3 ~ 30 V _{DC}
I-87068W	4-ch. Form-A Relay Output and 4-ch. Form-C Relay Output Module ; Form-A: 8 A @ 250 V _{AC} ; 8 A @ 28 V _{DC} ; Form-C: 5 A (NO) / 3 A (NC) @ 277 V _{AC} ; 5 A(NO) / 3 A(NC) @ 30 V _{AC}
I-87069W	8-ch. PhotoMOS Relay Output Module, Max. AC/DC: 0.13 A @ 350 V
I-87K Counter/Frequency Modules	
I-87082W	2-ch. Counter/Frequency Module, Isolated or Non-isolated Inputs
I-87K PWM Modules	
I-87088W	8-ch. PWM outputs, software support 1 Hz~100 kHz, (non-continuous), duty: 0.1 ~ 99.9%
I-87K GPS Modules	

I-87211W	Time-Synchronization and GPS module for getting UTC/local time and local Longitude/Latitude
----------	---

RS-485 Remote I/O Modules	
I-7000 DCON Protocol	www.icpdas.com.tw > Product > Solutions > Remote I/O Modules/Units > RS-485 Remote I/O Modules > I-7000 Modules
M-7000 Modbus RTU and DCON Protocol	www.icpdas.com.tw > Product > Solutions > Remote I/O Modules/Units > RS-485 Remote I/O Modules > M-7000 Modules
tM-7000 DCON, Modbus RTU, Modbus ASCII Protocol	www.icpdas.com.tw > Product > Solutions > Remote I/O Modules/Units > RS-485 Remote I/O Modules > tM Series Module
RS-485 Remote I/O Expansion Unit	
RU-87P1/2/4/8 Hot-Swap, Auto-Config.	www.icpdas.com.tw > Product > Solutions > Remote I/O Modules/Units > Remote I/O Expansion Unit > RS-485 Bus
I-87K1/4/5/8/9	www.icpdas.com.tw > Product > Solutions > Remote I/O Modules/Units > Remote I/O Expansion Unit > RS-485 Bus

Ethernet I/O Modules	
ET-7000 Web based	www.icpdas.com.tw > Product > Solutions > Remote I/O Modules/Units > Ethernet I/O > ET-7000
PET-7000 PoE Web based	www.icpdas.com.tw > Product > Solutions > Remote I/O Modules/Units > Ethernet I/O > PET-7000
tPET/tET-7000 Modbus TCP based (PoE)	www.icpdas.com.tw > Product > Solutions > Remote I/O Modules/Units > Ethernet I/O > PETL-7000 & tPET/tET
Ethernet I/O Expansion Unit	
I-8KE4/8-MTCP Modbus/TCP based	www.icpdas.com.tw > Product > Solutions > Remote I/O Modules/Units > Ethernet I/O > I-8KE4/8-MTCP

Performance Comparison Table of ISaGRAF PACs

Please click on the link [ISaGRAF Comparison Table](#) or follow the below steps:

1. www.icpdas.com

2. Click here to go to the ISaGRAF page

3. Comparison Table

The diagram illustrates the ISaGRAF PAC ecosystem, centered around the ISaGRAF PAC. It shows connections to various components and protocols:

- WinPAC** (top)
- IPAC** (right)
- ViewPAC** (bottom)
- µPAC** (left)
- HMI & SCADA Software** (bottom left)
- Modbus RTU Slave Protocol** (bottom left)
- DCON Protocol** (bottom right)
- Modbus Devices** (bottom left)
- EKAN** (bottom left)
- M-7000 Remote I/O** (bottom left)
- I-7000 Remote I/O** (bottom right)
- RU-87Pn/I-87Kn & I-87K Remote I/O** (bottom right)
- PC/HMI** (bottom right)
- SMS Short Message service** (bottom right)
- RS-232** (top right)
- RS-485** (bottom right)
- RS-485** (bottom right)

Specifications: VP-25W7 / VP-23W7

PAC Specification:

Models		VP -23W7	VP -25W7
System Software			
OS		Windows CE 5.0	
.Net Compact Framework		2.0	
Embedded Service		FTP server, Web server (supports VB script, JAVA script), Embedded SQL server	
SDK Provided		DII for eVC, DII for Visual Studio.Net 2005/2008	
Multilanguage Support		English, German, French, Spanish, Russian, Italian, Simplified Chinese, Traditional Chinese	
Development Software			
ISaGRAF Software	ISaGRAF Ver.3	IEC 61131 -3 standard	
	Languages	LD, ST, FBD, SFC, IL & FC; Support Soft -GRAF HMI: XP -8xx7-CE6, WP-8xx7, VP-2xW7 and WP-5xx7 PAC	
	Max. Code Size	1 MB	
	Scan Time	3 ~ 15 ms for normal program 15 ~ 50 ms (or more)for complex or large program	
Non-ISaGRAF		Options: MS eVC++ 4.0 or VS .NET 2005/2008 (VB.NET, C# .NET)	
Web Service			
Web HMI		PC running Internet Explorer can monitor/control PAC via Internet/modem	
Security		Support three-level username and password protection. (high/middle/low)	
CPU Module			
CPU		PXA270, 520 MHz	
SDRAM		128 MB	
Flash		96 MB	
Expansion Flash Memory		microSD socket with one 2 GB microSD card (support up to 32 GB microSDHC card)	
Dual Battery Backup SRAM		512 KB; data valid up to 5 years (for retain variables)	
EEPROM		16 KB	
RTC (Real Time Clock)		Provide second, minute, hour, date, day of week, month, year	
64-bit Hardware Serial Number		Yes, for Software Copy Protection	
Dual Watchdog Timers		Yes (0.8 second)	

Rotary Switch	Yes (0 ~ 9)	
Communication Interface		
Ethernet	RJ-45 x 1, 10/100 Base-TX (Auto-negotiating, LED indicators).	
USB 1.1 (host)	1	
COM 0	Internal communication with the high profile I -87K series modules in slots	
COM 1	-	
COM 2	RS-485 (Data+, Data -) with internal self-tuner ASIC; 2500 VDC isolated	
COM 3	RS-232 (RxD, TxD, CTS, RTS, DSR, DTR, CD, RI and GND); Non -isolated	
MMI (Man Machine Interface)		
LCD) " + Î Ì H: H Ì fl F Y g c ` i h]	
Touch Panel	-	Yes
Rubber Keypad	24 keys	6 Keys
Audio	Microphone-In and Earphone -Out	
LED Indicators	3 Dual-Color LEDs (PWR, RUN, LAN1, L1, L2, L3; L1 ~ L3 for User Programmable)	
I/O Expansion Slots		
Slot Number	3	
	Note: For High Profile I -8K and I -87K Modules Only	
Mechanical		
Dimensions (W x L x H)	182 mm x 158 mm x 125 mm	
Installation	Panel Mounting	
Ingress Protection	Front panel: IP65	
Environmental		
Operating Temperature	-20 ~ +70°C	
Storage Temperature	-30 ~ +80°C	
Ambient Relative Humidity	10 ~ 90% RH (non-condensing)	
Power		
Input Range	+10 ~ +30 V DC	
Isolation	1 kV	
Capacity	12.5 W	
Consumption	7.2 W	

VP-2xW7 ISaGRAF Specifications:

Protocols (some protocols need optional devices)	
NET ID	1 ~ 255, user-assigned by software
Modbus TCP/IP Master	Link to max. 100 devices that support Standard Modbus TCP/IP Slave protocol (FAQ-113)
Modbus RTU/ASCII	Max. 10 ports: COM2, 3 and COM5 ~ 14. (To connect to other Modbus Slave devices).

Hot-Swap and Redundant System	<p>Must enable the 2nd Ethernet port in the optional I8135W card.</p> <p>'s LAN1 and 2nd Ethernet ports always. One or two or more PC / HMI / SCADA can communicate with this redundant system via one of the two given active IP. So the PC / HMI / SCADA can access to the system easily without any notice about which VP-2xW7/2xW6 is currently active. Moreover, the new redundant system can integrate with the RU87P4 and RU -87P8 expansion unit plus the I-87K high-profile I/O cards to support the hotswap application. If the I/O card is damaged, the maintenance person just takes one good -card with same model number to hot-swap the damaged one without stopping this redundant system. (FAQ -093)</p>	
CAN/CANopen	<p>COM3 or COM5 ~ COM14 can connect one I7530 (Converter: RS-232 to CAN) to support CAN/CANopen devices and sensors. One PAC supports max.10 RS -232 ports to connect max.10 I -7530. (*)</p>	
CANopen Master	<p>Support the I-8123W CANopen Master card to connect other CANopen slave devices. (FAQ -145)</p>	
HART Solutions	<p>Support I-87H17W modules in slot 0 to 2 to communicate with other HART devices.</p>	
FTP Client	<p>Support FTP client to upload files in the PAC to a remote FTP server on PC.(FAQ -151)</p>	
Soft-GRAF HMI	<p>Support the SoftGRAF HMI . User can use the Soft-GRAF Studio on the PC to design the HMI screen and then download it to the PAC to display the HMI on the PAC.(FAQ -146)</p>	
Optional I/O Functions (Refer to ISaGRAF PAC I/O Selection Guide for I/O Module list)		
PWM Output	High Speed PWM Module	I-7088, I-8088W, I-87088W: 8-ch. PWM outputs, software support 1 Hz~100 kHz (non-continuous), duty: 0.1~99.9%
	DO Module as PWM	8-ch. max. 250 Hz max. For Off=2 & On=2 ms. Output square curve: Off: 2 ~ 32766 ms, On: 2 ~ 32766 ms. Optional DO Boards: I -8037W, 8041W, 8041AW, 8042W, 8050W, 8054W, 8055W, 8056W, 8057W, 8060W, 8063W, 8064W, 8068W, 8069W(Relay Output boards cannot generate fast square wave)
Counter, Encoder, Frequency	Parallel DI Counter	8-ch. max. For 1 controller. Counter val: 32 -bit. 250 Hz max. Min. ON & OFF width must > 2 ms. Optional DI boards: I -8040W, 8040PW, 8042W, 8046W, 8048W, 8050W, 8051W, 8052W, 8053W, 8053PW, 8054W, 8055W, 8058W, 8063W.
	Serial DI Counter	Counter input: 100 Hz max. Counter value: 0 ~ 65535 (16-bit) Optional serial I-87K DI boards: I -87040W, 87046W, 87051W, 87052W, 87053W, 87053WA5, 87054W, 87055W, 87058W, 87059W, 87063W.
	Remote DI Counter	All remote I-7K/I-87K DI modules support counters. 100 Hz max. Value: 0 ~ 65535
	High Speed Counter	I-87082W: 100 kHz max., 32-bit; I-8084W: 250 kHz max., 32-bit
	Encoder	<u>I-8093W</u> : 3-axis Encoder Module, max. 1M Hz for quadrant input mode, max. 4 MHz for pulse/direction and cw/ccw input mode. (FAQ -112) <u>I-8084W</u> : 250 kHz max., 4-ch encoder, pulse/direction or up/down or A/B phase (Quad mode), Not support Encoder Z-index. (FAQ -100)
Frequency	I-87082W: 2-ch, 1 Hz ~ 100 kHz; I -87088W: 8-ch, 0.1 Hz ~ 500 kHz; I -8084W: 8-ch, 1 Hz ~ 250 kHz;	

Motion	Motion Control	one I-8091W (2-axis) or two I-8091W (4-axis) can do motion control. only one I-8091W can do X-Y dependent motion.
Port	Second Ethernet	VP-2xW7 / VP-2xW6 can add one optional I-8135W card in its slot 0 ~ 2 to expand the second Ethernet port.
<p>* Note: COM5 ~ COM14 are resided at the expansion boards if they are plugged on slot0~2 of VP-2xW7.</p> <p>* ISaGRAF FAQ: http://www.icpd.com/faq/isagraf.htm</p> <p>* Recommend to use NS -205/NS -208 Industrial Ethernet Switch.</p>		

Chapter 1 Typical Application

The website for the applications supporting list of all ISaGRAF PACs :
http://www.icpdas.com/products/PAC/common_file/application-notes.htm

1.1 Soft-GRAF HMI Application: Colorful HMI

- ' Soft-GRAF Studio:
 - Ø Simplify HMI screen editing (Mouse drag and drop)
 - Ø HMI without writing programming language
- ' Support various and colorful HMI objects:
 - Ø Page (Max. 200, password security)
 - Ø Numeric (Input, input security, display)
 - Ø Text (Dynamic/static text display)
 - Ø Picture (Animated/static picture display)
 - Ø Moving Trace (1-axis or 2-axis)
 - Ø Bar-meter
 - Ø Button displayed as picture
 - Ø Button displayed as text
 - Ø Built-in various objects
- ' Multi-language: English, Traditional Chinese, Simplify Chinese, Russian, etc.
- ' HMI behave smoothly
- ' More at Ch.2.5 and FAQ www.icpdas.com > FAQ > Software > ISaGRAF Ver.3 - 146

Design the Control logic and HMI by one single ISaGRAF Software

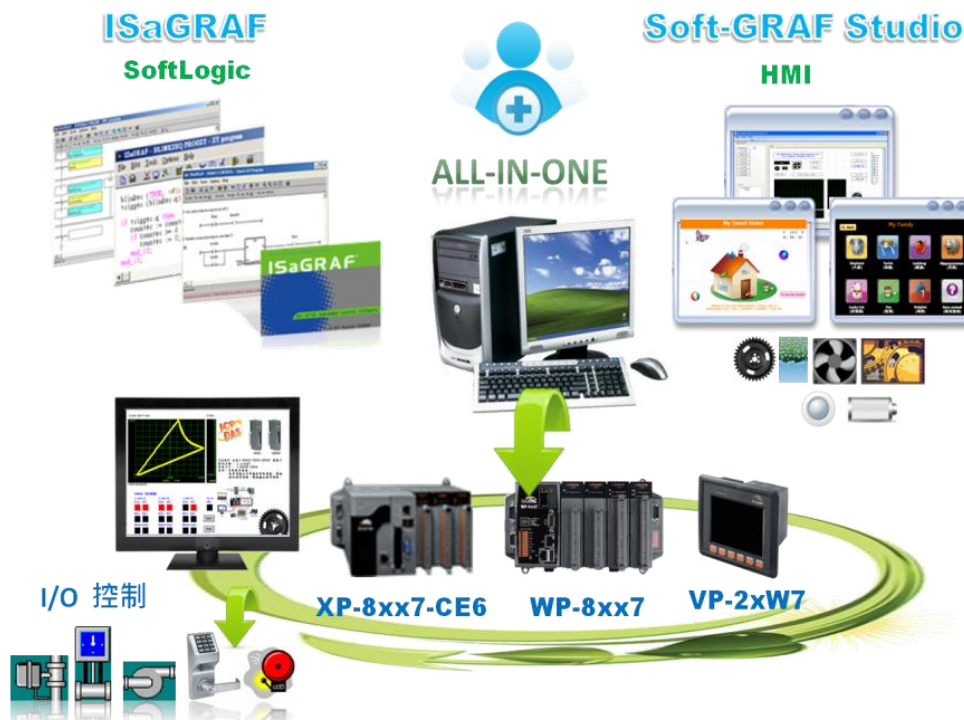

1.2 eLogger HMI Application

- ICP DAS eLogger is an easy and useful HMI development tool which helps user to create user-friendly pictures and control items.
- More at: www.icpdas.com > FAQ > Software > ISaGRAF Ver.3 . FAQ-115

ISaGRAF
Software Development Tool

- Simulate without PAC
- Debug / Control / Monitor On-Line
- Six Open SoftLogic Languages(LD, ST, ..)

Free HMI Toolkit
eLogger
HMI Development Tool

- HMI
- Easy & Useful

ICP DAS

WP-8x47 / 8x37 XP-8xx7-CE6 VP-25W7 / 23W7

1.3 Redundant Communication System

- More at www.icpdas.com > FAQ > Software > ISaGRAF Ver.3 - 119
- RS-485 or Ethernet redundant communication mechanism/applications.
- For XP-8xx7-CE6 WP-8xx7 & VP-2xW7 series.

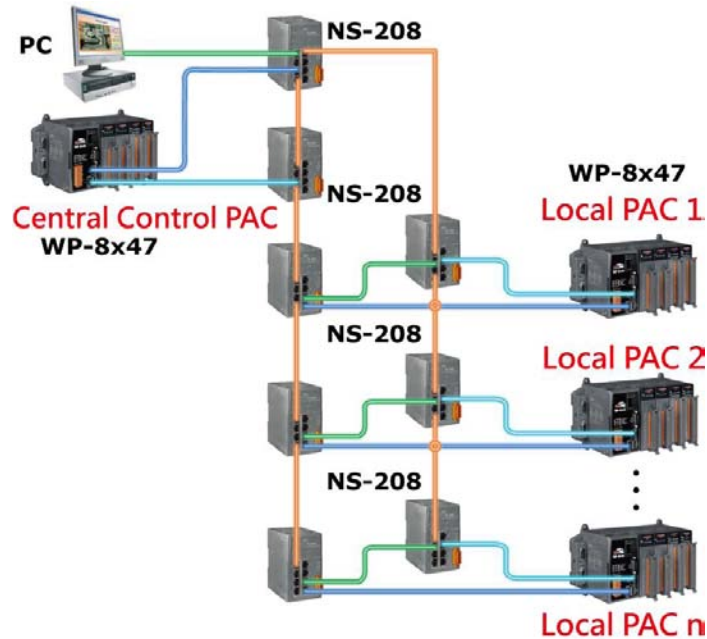

1.4 New Hot-Swap and Redundant System

- Please plug one I-8135W and enable the 2nd Ethernet port of VP-25W7/23W7.
- If one Ethernet cable of VP-25W7/23W7 is broken or damaged, the other one will still work.
- If one controller is damage, the other one will take over the control of the RS-485 I/O.
- PC/HMI can connect to this redundant system by one or two active IP.
- More at www.icpdas.com > FAQ > Software > ISaGRAF Ver.3 (English) - 093

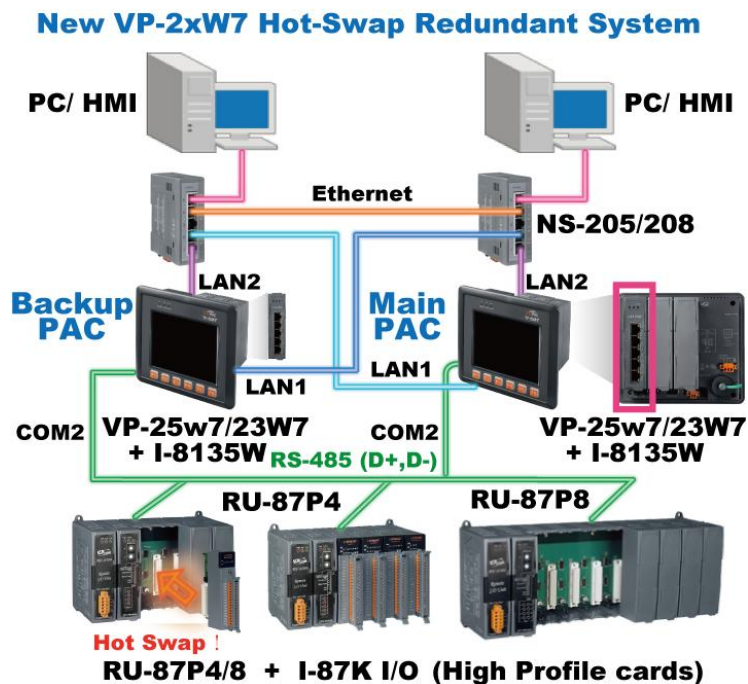

1.5 Modbus Master: TCP/IP

- Each VP-25W7/23W7 or WP-8xx7 supports to link to max. 100 Modbus TCP/IP slave devices.
- Support various Standard Modbus TCP/IP Slave devices.
- More at www.icpdas.com > FAQ > Software > ISaGRAF > FAQ-113

Modbus TCP/IP Master Application

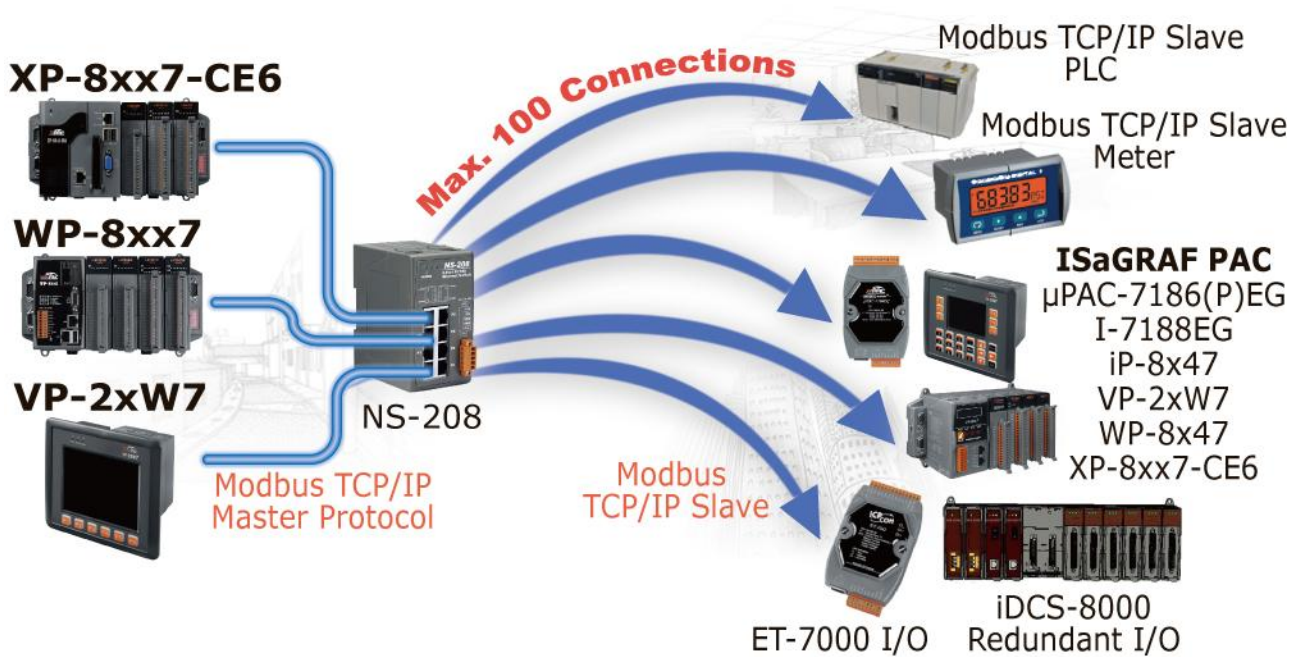

1.6 Modbus Master: RTU, ASCII, RS-232/485/422

- Support up to 10 ports: COM2~COM3 & COM5~COM14 (if I-8112iW/ 8114W/ 8114iW/ 8142iW/ 8144iW in Slot0 ~ 2)
- Can link to Modbus PLC or M-7000 I/O or Modbus devices (Power meter, temperature controller, inverter etc.)

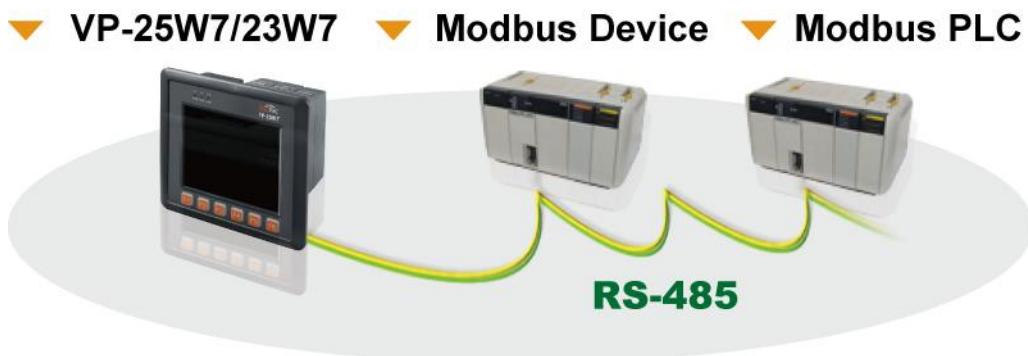

1.7 Modbus Slave: RTU/TCP

- ' Modbus RTU (RS-232/485/422): max. 5 ports
- ' Modbus TCP/IP: max. 32 connections

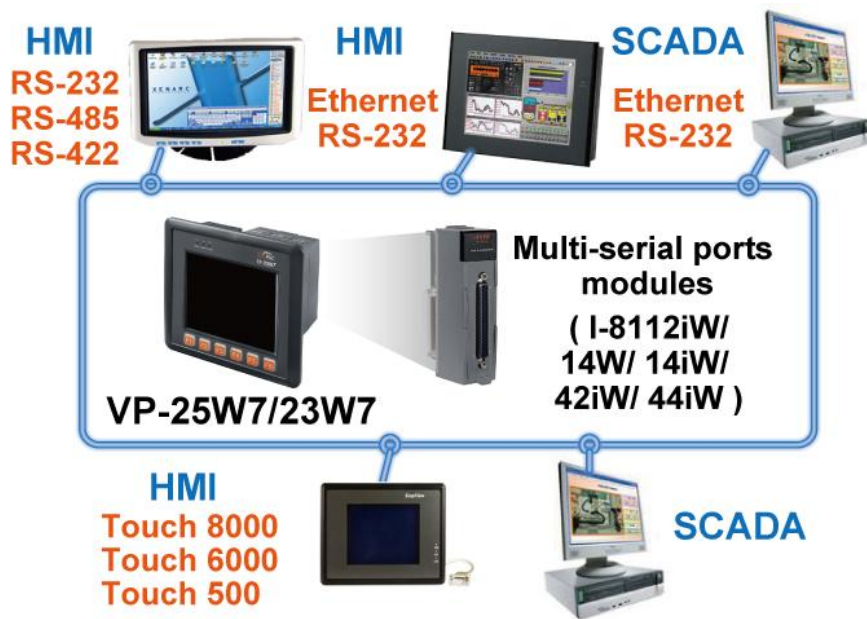

1.8 Communicate With Other TCP/IP Server or UDP Client/Server Devices



1.9 Multiple Web HMI Monitor & Control Everywhere!

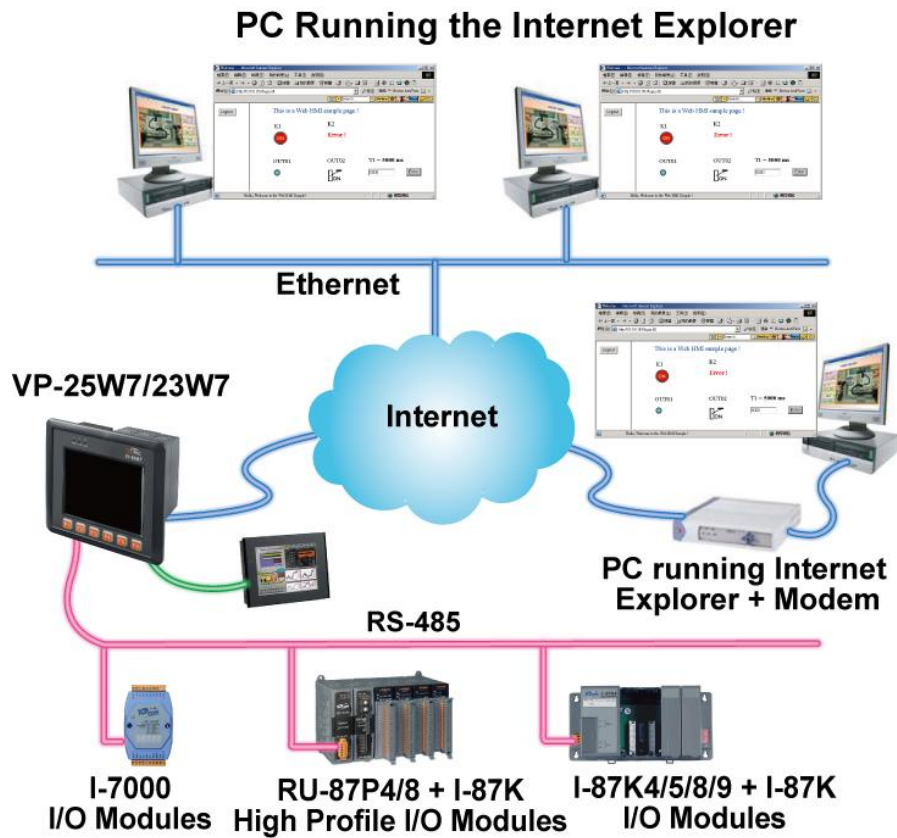

1.10 Send Email with One Attached File

More at www.icpdas.com > FAQ > Software > ISaGRAF Ver.3 (English) - 067

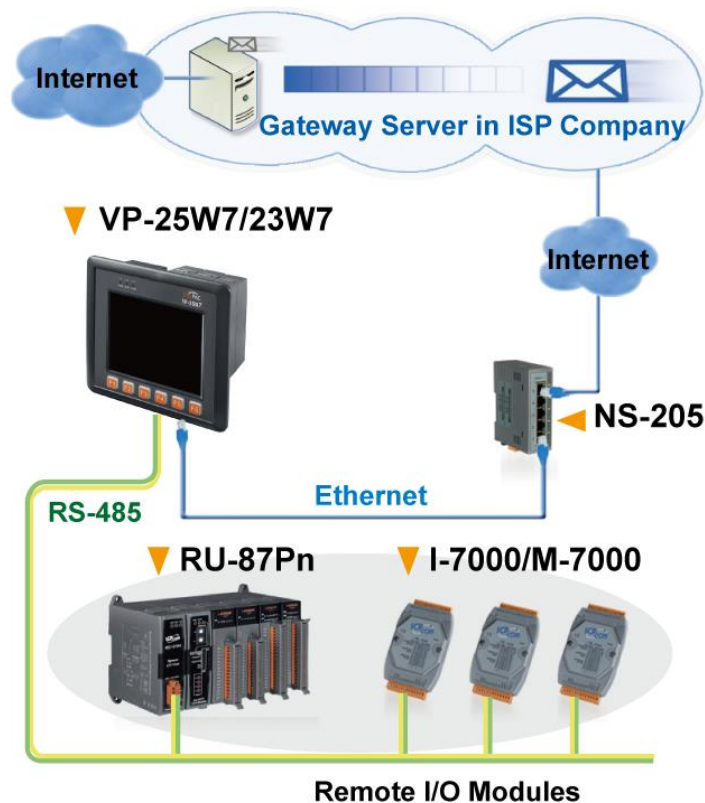

1.11 Data-Recorder & Data-Logger

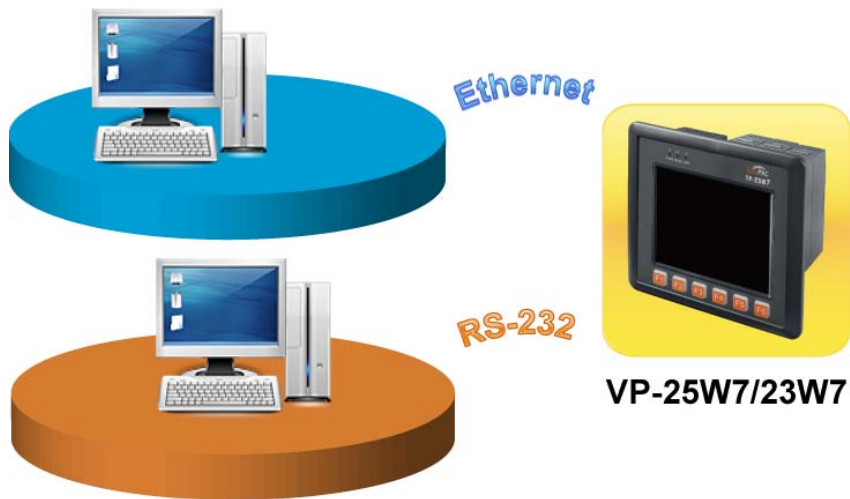

PC can load the data file stored in the VP-25W7/23W7's Flash Disk or micro-SD card by ftp or by Web HMI.

1.12 Remote I/O Application

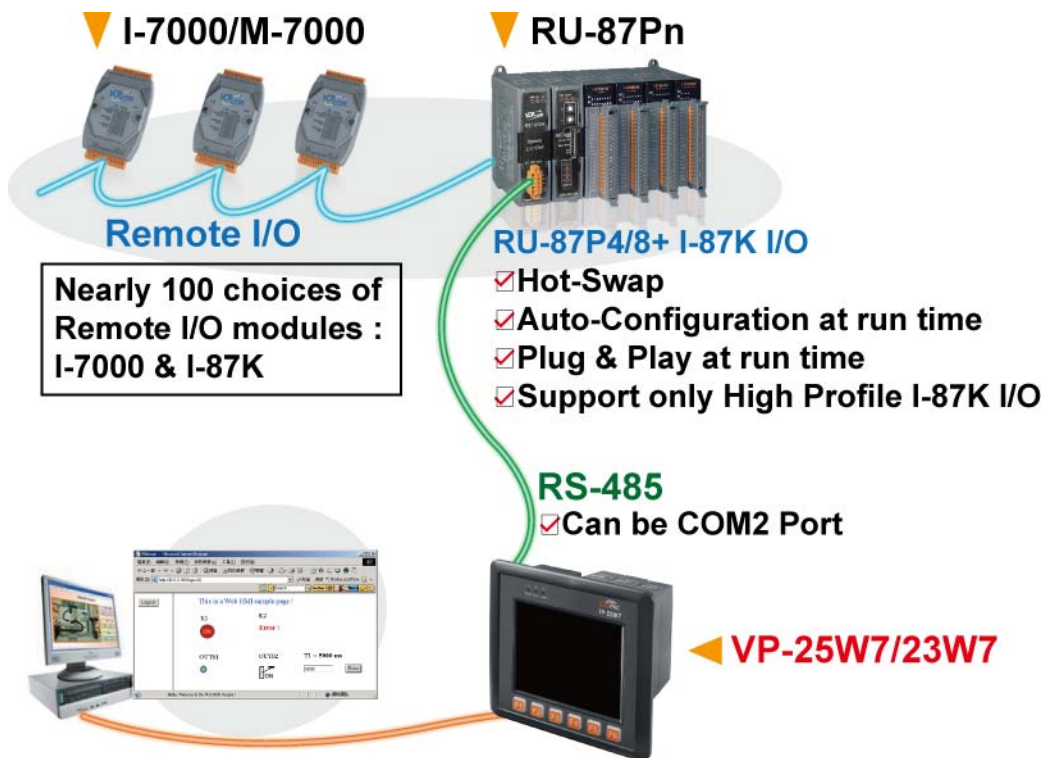

1.13 SMS: Short Message Service

- Short message can be sent in multiple language format (like Chinese, English... others) and pure text can be sent/received.
- More at www.icpdas.com > FAQ > Software > ISaGRAF Ver.3 (English) - 111

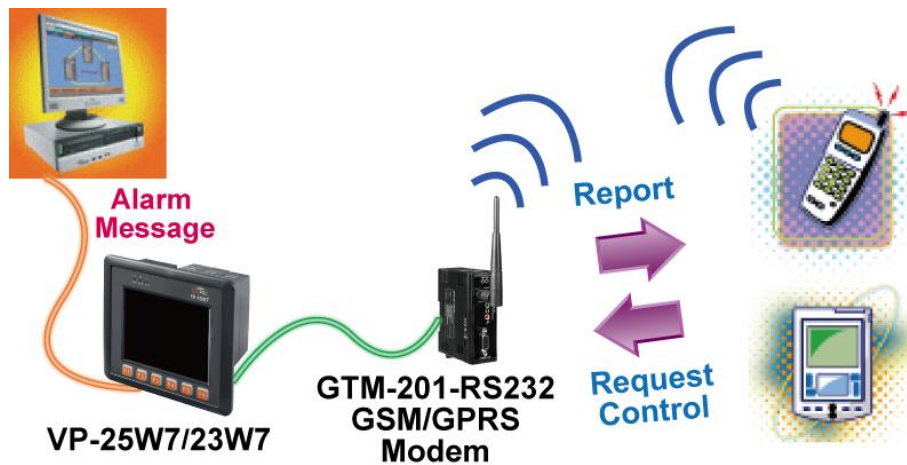

1.14 Auto-report Acquisition & Control Data

- VP-25W7/23W7 can use UDP IP Client to auto-report acquisition data & control data to local or remote internet PC/Server.
- Advantage** : Every ViewPAC can report data to Internet IP
- More at www.icpdas.com > FAQ > Software > ISaGRAF Ver.3 (English) - 065

Stable and Cost-effective Data Acquisition Auto-Report System

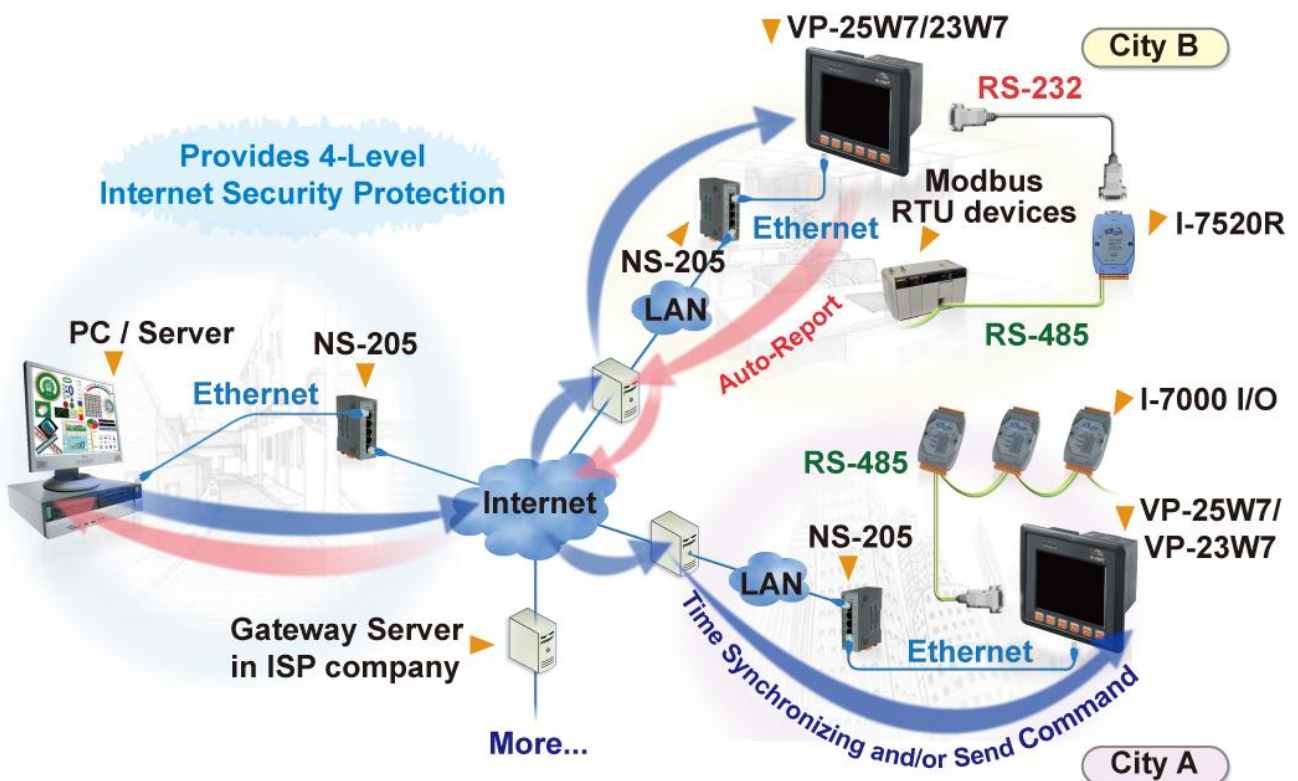

1.15 Motion Control

- ' One **I-8091W** can control 2 axes: X-Y plane, or 2 axes independent
- ' Two **I-8091W** can control 4 axes: X-Y plane + 2 axes independent, or 4 axes independent
- ' Encoder Modules:
 - I-8084W**: 4-axis, without Z-index
 - I-8090W**: 3-axis



1.16 Stress Monitoring Application of Constructions

- ' More at www.icpdas.com > FAQ > Software > ISaGRAF Ver.3 (English) - 091, 128

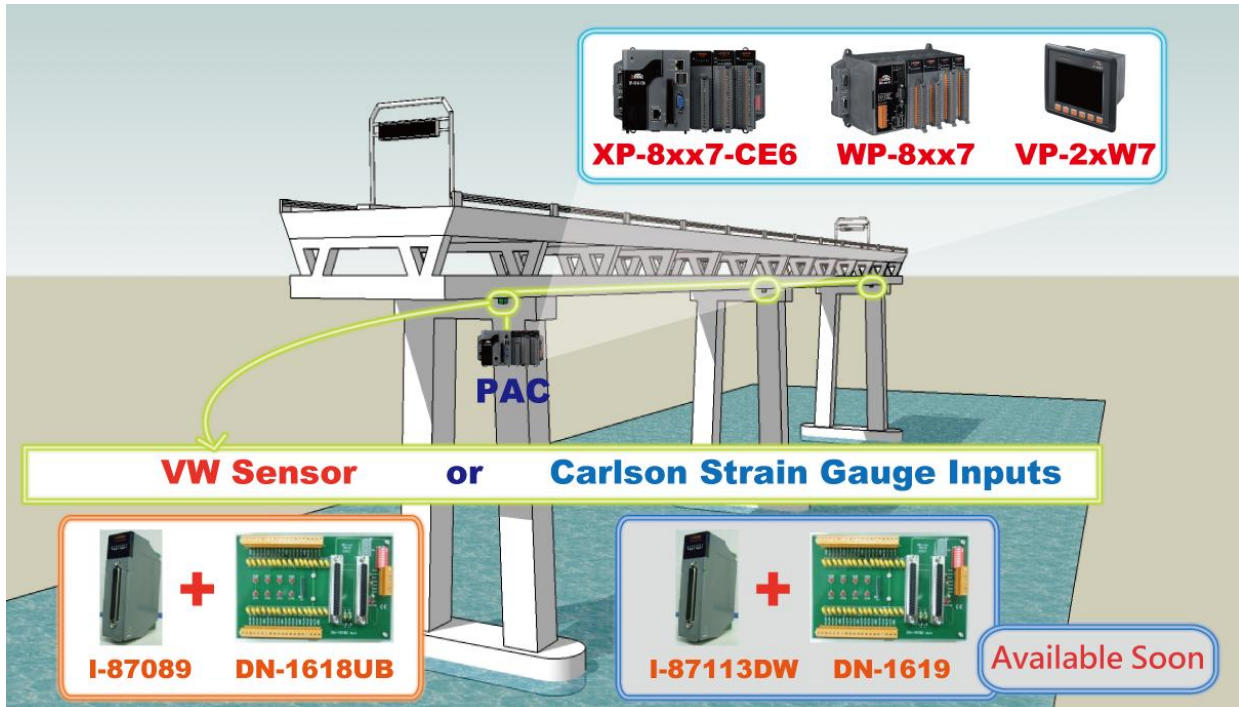

1.17 Fast FRnet Remote I/O

Advantage of FRnet I/O:

- Fast I/O scan: About 3 ms/scan.
 PLC scan time is about 9 ms, then the scan time for all will be 9 ms, not 3 ms)
- More at www.icpdas.com > FAQ > Software > ISaGRAF Ver.3 (English) - 082

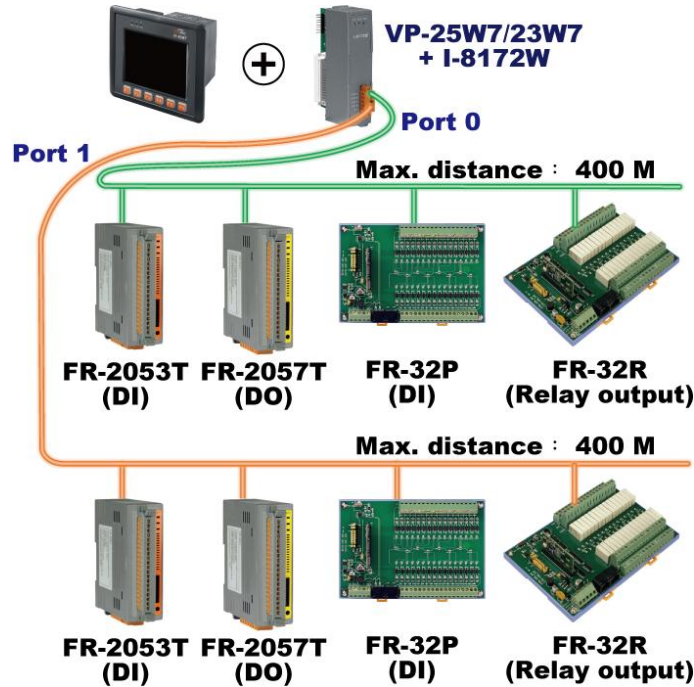

1.18 Integrate with CAN/CANopen Devices & Sensors

- VP-25W7/23W7 supports max. 10 I-7530 (RS-232 to CAN Converter)
- Please refer to www.icpdas.com > FAQ > Software > ISaGRAF Ver.3 (English) > 086

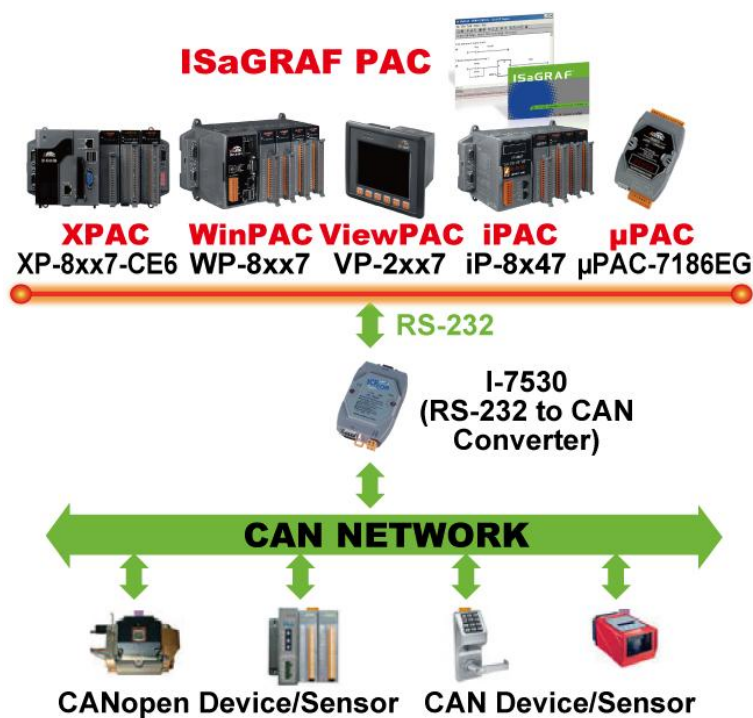

1.19 VIP Communication Security

- ' Set VIP (Very Important IP No.) for Modbus TCP/IP security.

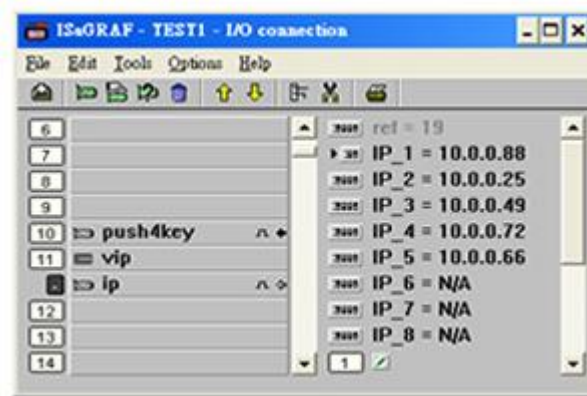

1.20 ISaGRAF PAC Connects the Smart Power Meter

- ' Support standard Modbus protocol, support multiple RS-485 ports to connect to multiple PM-2133/2134 Smart meters
- ' PM-2133/2134 is a series of 3 Phase/4 Loops 1 Phase Compact Smart Meter with true RMS energy and power parameters measurement in compact size. The ISaGRAF PACs combining with PM-213x can apply to various control/monitor systems about intelligent electric power measurement.
- ' More at www.icpdas.com > [FAQ](#) > [Software](#) > [ISaGRAF Ver.3](#) > [129](#)

