

ISA Analog Input Board

ISO-LDH/L

Isolated strain gauge type Load Cell input board



Features

- 500 VDC photo-isolation protection
- One strain gauge input channel
- One analog input channel
- Built-in 1K bytes FIFOs
- Excitation voltage for Load Cell: 12V, 50 mA
- Maximum gain up to 40,000
- Programmable 12-bit resolution DC offset voltage
- Second order low-pass filter build-in
- Direct connection to strain gauge type Load Cell
- 8-channel 12-24V isolated digital input
- 7-channel isolated open-collector digital output
- Programmable 8-bit LED indicator
- Command set programming

Functional Description

The ISO-LD series is a bus-isolated Load Cell input board. The isolation inputs can operate with up to 500Vrms of common-mode voltage. The ISO-LD series features a 12-bit analog-to-digital converters, on board 1 K bytes FIFO buffer, one Load Cell signal input channel, one analog input channel, 8-channel 12-24V isolated digital inputs, 7-channel isolated open-collector digital outputs, one programmable 8-bit LED indicator to indicate the magnitude of strain gauge input signal. The ISO-LD series board is suitable for static force measurement and dynamic force analysis. Because there are on-board excitation voltage, high-gain amplifier, user don't have to buy any excitation voltage and signal conditioning module.

The board also has some special features, such as:

1. 12-bit programmable offset voltage. Therefore the user can cancel the DC bias and amplify the AC signal
2. The isolated structure eliminate the ground loop noise and protect your computer
3. On board 1K FIFOs buffer support gap-free A/D conversion under DOS and Windows environment
4. Except the Load Cell input channel, there are a lot digital I/O and one analog input channel. The user can use ISO-LD to implement a measurement and analysis system.

Applications

- Strain Gauge type Load Cell measurement
- Dynamic force on-line monitoring system
- Dynamic pressure measurement

Specifications

Analog Input

- Number of channels: 1 Load Cell input channel & 1 analog input channel
- Resolution: 12-bit
- ADC conversion rate: 20 KS/s max
- Input Impedance: 10,000M Ω || 6pF
- Bias Current: ± 3 nA max
- Input offset current: ± 2 nA max
- CMRR: 90 dB min
- Recommended warm-up time: 10 minutes
- On chip sample & hold

ISO-LDH Input Range

- Analog input range: 0~10V, 0~1V, 0~0.1V, 0~0.01V
- Strain Gauge input range: 0~37.5 mV

Gain	Input range(mV)
400	0~37.5
4,000	0~15
40,000	0~12.75

ISO-LDL Input Range

- Analog input range: 0~10V, 0~5V, 0~2.5V, 0~1.25V
- Strain Gauge input range: 0~37.5 mV

Gain	Input range(mV)
400	0~37.5
8,00	0~25
1,600	0~18.75
3,200	0~15.625

- Load Cell offset voltage adjustment: 0~ -5V, 12-bit

ISO-LDH/LDL

Isolated strain gauge type Load Cell input board

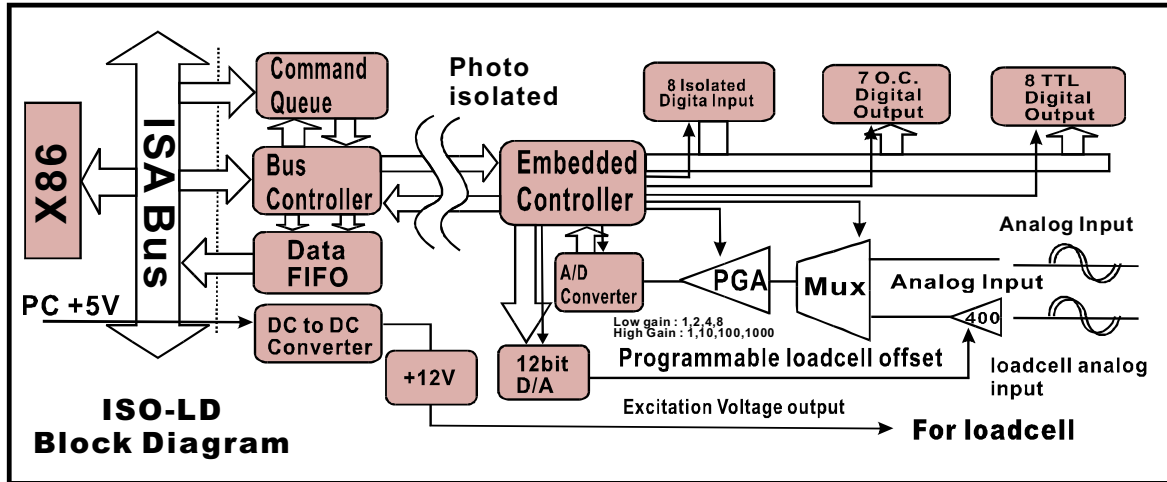

Digital I/O

- 8 photo-isolated 12~24V digital input
- 7 isolated open-collector digital output (NPN type)
- Sink current: 100 mA
- 8 TTL/LED output

General Specifications

- I/O connector:
 - one 9-pin D-Sub female
 - one 25-pin D-Sub female
 - one 10-pin ribbon male
- Power requirements: +5V @ 400 mA
- Operating temperature: 0 ~ 60°C
- Operating humidity: 0 ~ 90% non-condensing
- Storage temperature: -20 ~ 70°C
- Dimensions: 182 mm x 122 mm

Ordering Information

Standard

- ISO-LDH:** 12-bit high-gain Load Cell input board
- ISO-LDH/S:** ISO-LDH with DN-25
- ISO-LDL:** 12-bit low-gain Load Cell input board
- ISO-LDL/S:** ISO-LDL with DN-25

Optional

- DN-25:** DIN-rail mounting terminal board
- S-50:** S-type Load Cell

Pin Assignment

CN1

Exec+	1	6	GND
Vin 1+	2	7	Vin 1-
3 N.C.	3	8	Vin 0
4 N.C.	4	9	N.C.
5 N.C.	5		

CN2

DI 0+	1	14	DI 0-
DI 1+	2	15	DI 1-
DI 2+	3	16	DI 2-
DI.COM	4	17	DI 3-
DI 4-	5	18	DI 5-
DI 6-	6	19	DI 7-
DO.COM	7	20	DO.GND
DO 0	8	21	DO 1
DO 2	9	22	DO 3
DO 4	10	23	DO 5
DO 6	11	24	+12VDC
+12VDC	12	25	GND
GND	13		

CN3

LED 1	1	2	LED 2
LED 3	3	4	LED 4
LED 5	5	6	LED 6
LED 7	7	8	LED 8
N.C.	9	10	+5V