



# CAN Series Products



## Intelligent RS-232 to CAN Converter



I-7530

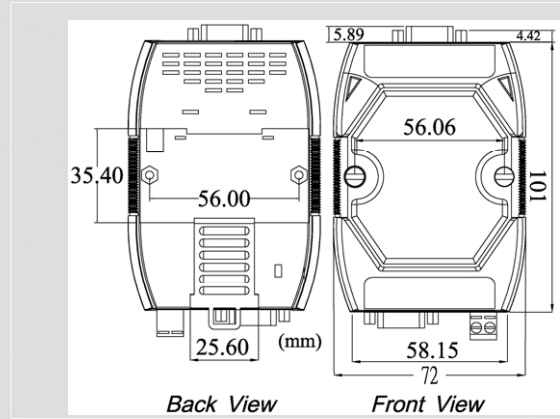

Dimensions

The PC can be the CAN host, monitor or HMI to access/control the CAN device through the CAN network by the I-7530 Converter. The programmable RS-232 device (For example: PACs of ICP DAS) can use the serial port to connect to the CAN network via the I-7530 module. The I-7530 is designed to unleash the power of CAN bus via RS-232 communication method. It accurately converts messages between CAN and RS-232 networks. This module let you to communicate with CAN devices easily from any PC or devices with RS-232 interface.

### Features

- Compatible with CAN specification 2.0A and B
- Fully compatible with ISO 11898-2 standard
- Support various bauds from 10K bps to 1M bps
- Jumper for 120 Ω terminator resistor
- Software configurable CAN and RS-232 communication parameters
- Power, data flow and error indicator for CAN and RS-232
- Watchdog inside
- OEM for ISO 11898-3 standard (Low Speed Fault tolerance)
- Support transparent communication mode

- Serial COM command error response selection
- Easy tool to transmit / receive CAN messages

### CAN Monitor & Data log Tools

- Show CAN messages by hex or decimal format
- CAN messages with time stamp
- Easy-to-use data logger for the diagnosis of CAN Networks and recording of process data.
- Send the defined CAN messages manually or cyclically.

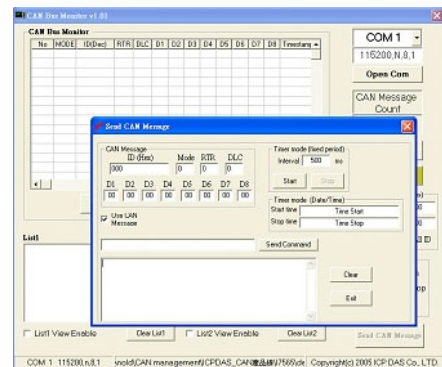

### Utility Features

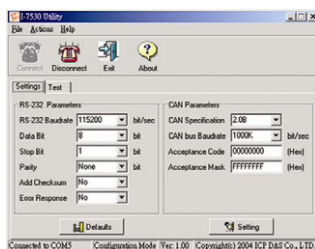

- CAN bus baud rate configuration
- CAN acceptance filter configuration
- CAN 2.0A or 2.0B specific selection
- Serial COM baud rate and data bit setting

### Wire Assignments

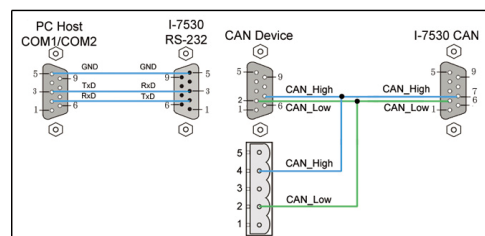



## Hardware Specifications

Item	I-7530
CAN Controller	Microprocessor inside with 20MHz
CAN Port Channels	1
CAN Transceiver	Philips 82C250
CAN Connector	ISO/IS 11898-2, 9-pin D-sub connector
Baud Rate	10K, 20K, 50K, 100K, 125K, 250K, 500K, 800K and 1Mbps
Protection	3000 VDC power protection on CAN side, 2500Vrms photo-couple isolation on CAN bus
Terminator Resistor	Selectable 120Ω terminator resistor by jumper
Support Protocol	CAN 2.0A/2.0B
Pin out	C.I.A. DS-102 (CAN_H = 7, CAN_L = 2, GND = 3)
Receive Buffer	1000 data frames
<b>RS-232 Interface</b>	
Connector	Female DB9
Baud Rate	110, 150, 300, 600, 1200, 2400, 4800, 9600, 19200, 38400, 57600, 115200 bps
Data Bits	5, 6, 7, 8
Parity	Odd, even, or no parity
Stop Bits	1, 2
Pinout	DCE (TX = 2, RX = 3, GND = 5)
Receive Buffer	900 data frames
<b>General</b>	
Power Consumption	1W
Power Requirement	Unregulated +10V DC ~ +30V DC. Power reverse protection, Over-Voltage brown-out protection
LEDs	ON LED: Power and Data Flow; ERR LED: Error
<b>Environment</b>	
Operating Temp.	-25°C to 75°C
Storage Temp.	-40°C to 80°C
Humidity	5~95% non-condensing
Dimensions	118mm x 72mm x 33mm (H x W x D)

## Applications

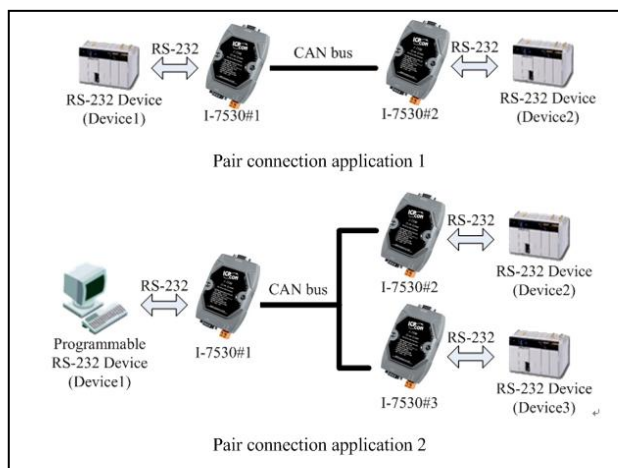
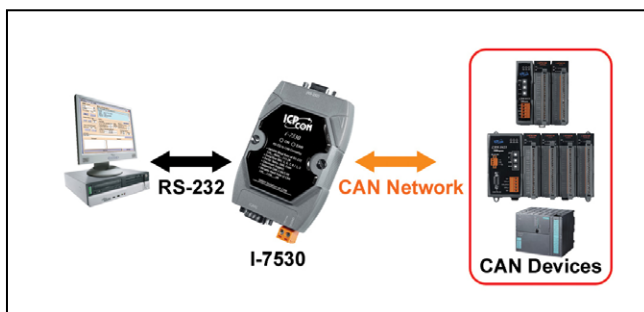

## Ordering Information

<b>I-7530</b>	Intelligent RS-232 to CAN Converter
<b>I-7530 CR</b>	Intelligent RS-232 to CAN Converter (RoHS)