

# SERVO-300

## 3-AXIS, High-speed Servo Motor Control Board

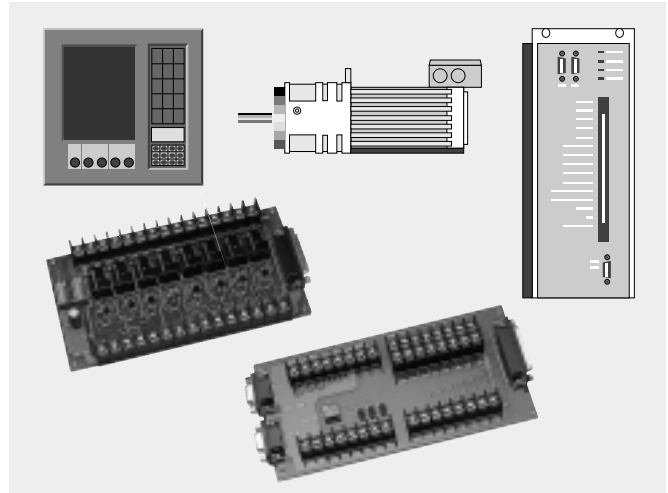

### Functional Description

SERVO-300 is a 3-axis, command-type, servo control board with quadrature encoder feedback. The embedded CPU of SERVO-300 performs the motion commands transferred from PC via a 2K bytes FIFO. The CPU also send the information of position and status to the PC via another 2K bytes FIFO. Since there are two FIFO on the board, SERVO-300 is suitable for windows operating system. The SERVO-300 provides DOS, Windows 98/95, NT, and LabView drivers. The SERVO-300 provides comprehensive motion capability with performance and reliability that is really low in cost and easy to use.

### Features

- Control 3 servo axes
- V command output
- FIFO bus interface
- Command type, totally 42 commands
- Provides simulation/open loop/closed loop modes
- Embedded CPU on board
- Linear interpolation/circular interpolation
- 2500 points per axis, pitch error compensation
- Can detect the hardware failure
- Direction of each axis can be configurable

- Software/Hardware emergency stop
- 2500 Vrms optical isolation
- Auto protection for each limit switch
- Provides DOS, Windows 98/95, NT, LabView drivers

### Applications

- X-Y table control
- Robotics
- Mechanical positioning control

### Specifications

- No. of axes: 3 axes
- Position accuracy: +/-1 quadrature count
- Output Type: 12-bit analog output with +/-10V
- Control algorithm: PD control
- Sampling rate: 2.2ms for 3-axis control system
- Two FIFO buffer
- FIFO size: 2K byte/each
- 8 isolated digital inputs & 7 isolated digital outputs
- Forward, Backward, Home, limit switch per axis
- Connector 1: D-sub 9-pin connector for analog output and servo-on signal
- Connector 2: D-sub 9-pin connector for encoder input and limit switch

- Connector 3: D-sub 25 connector for limit switch and relay output
- Connector 4: D-sub 25 connector for encoder input
- Power Requirements: +5V: 950mA typ.
- Operating temp range: 0° to 60°C
- Storage temp range: -20°C to 70°C
- Humidity: 95% non-condensing
- Weight: 181g
- Dimensions: 208mm x 121mm

### Software DDA Technology

For precise control and adjustable speed, the Software DDA will divide the command into several equal delta commands. It is very important to select a proper DDA value for the system.



# SERVO-300

## 3-AXIS, High-speed Servo Motor Control Board

Pin assignment of CN1 Connector

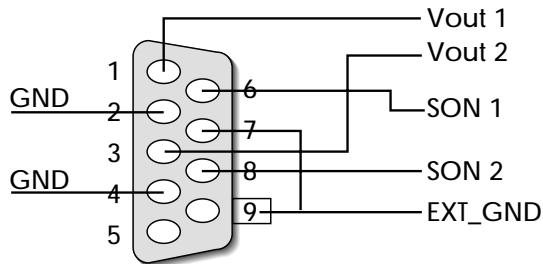

Pin assignment of CN3 Connector

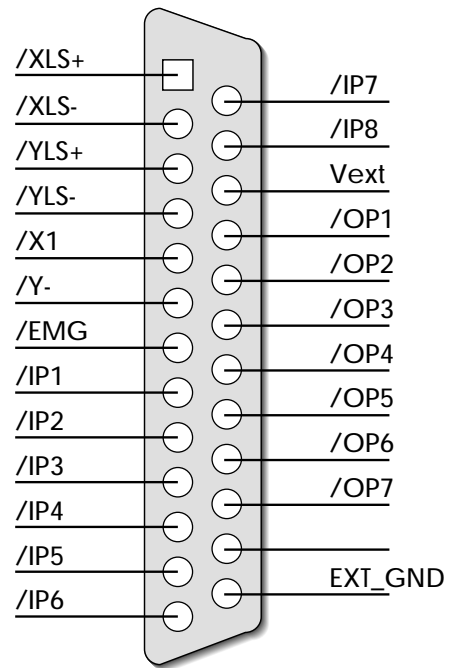

Pin assignment of CN2 Connector

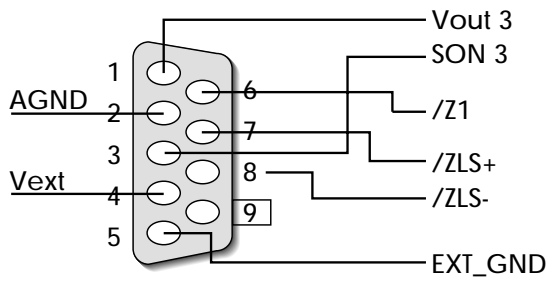

Connection between Encoder and Servo-300

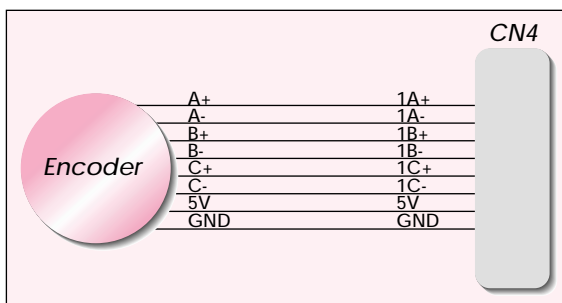

Pin assignment of CN4 Connector

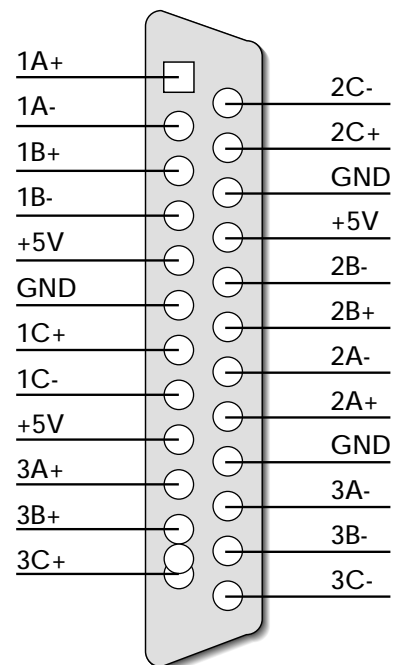

Connection between Open-collector type Encoder and Servo-00

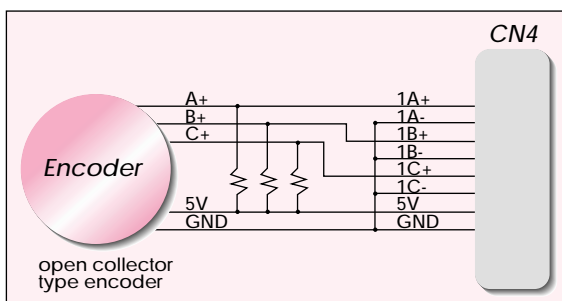

Motion Board



# SERVO-300

## 3-AXIS, High-speed Servo Motor Control Board

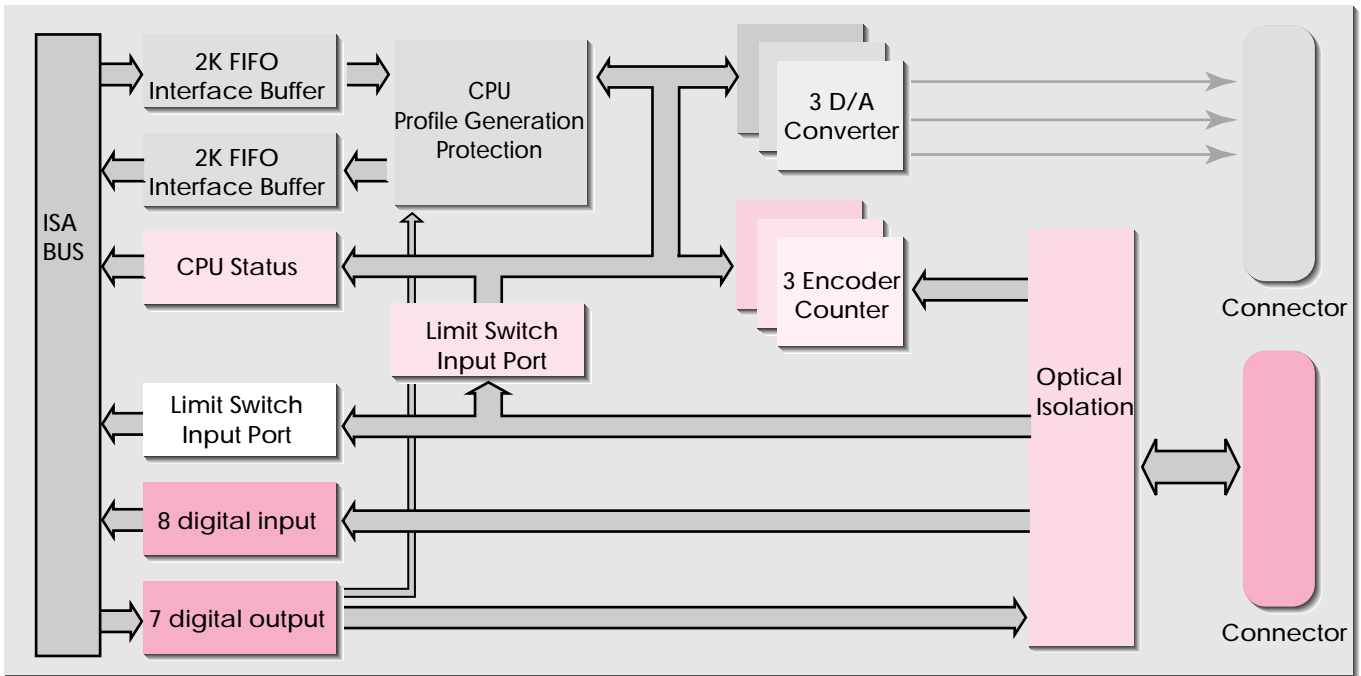

Figure A: Block Diagram

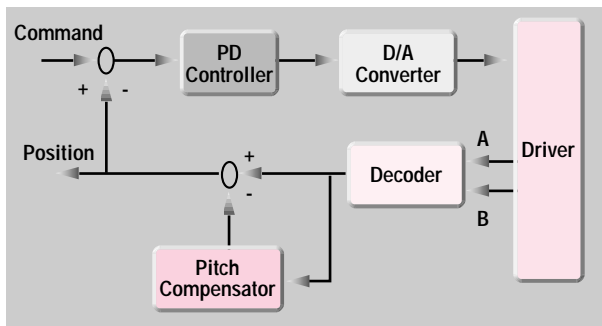

Figure B: Servo-Loop Diagram

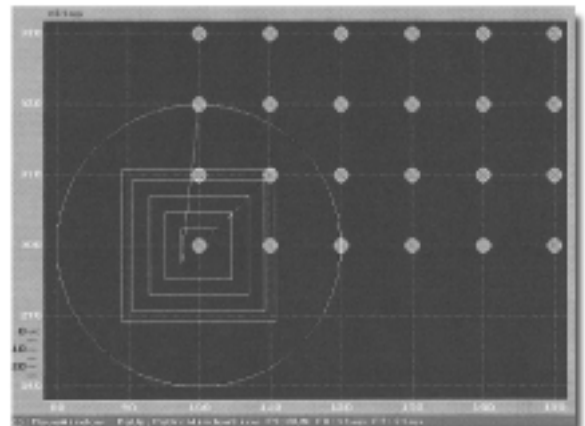

Figure D: Customer made Machine-Control Software

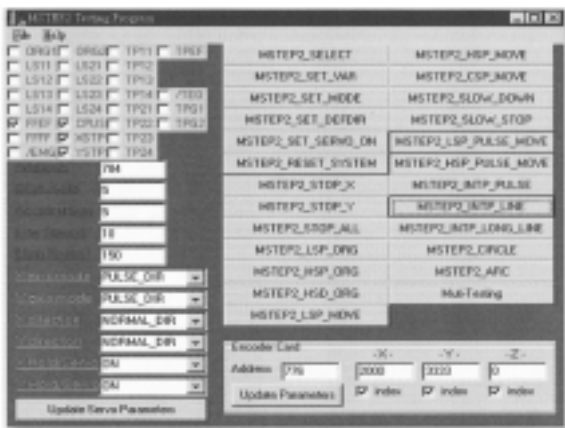

Figure C: Test Panel

### Order Description

- SERVO-300  
3-axis SERVO motor controller board
- DB-200  
Encoder interface board for SERVO-300
- DB-8R:  
Relay board for SERVO-300

Motion Board