

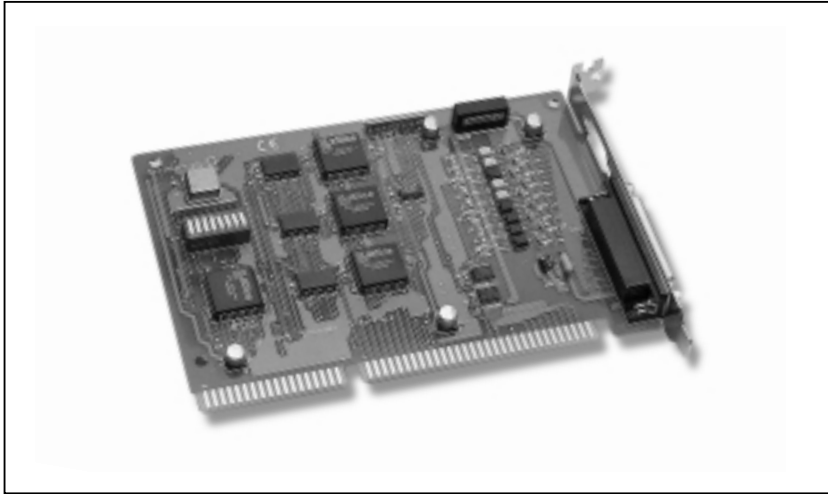

Encoder 300

3 Axes Encoder interface board



Functional Description

This board is a 3-axis quadrature encoder interface board for the IBM PC/AT bus compatibles. For each encoder, phase 0, phase 90 and index pulse inputs are provided. Inputs may be single ended (A, B, C) or differential (A+, A-, B+, B-, C+, C-). Power and ground connections are provided for encoder use if needed. Inputs are conditioned by a four-stage digital filters. The maximum input rate in quadrature decode mode is 1MHz. The conditioned input are applied to a 16-bit counter. The counter may be used for quadrature decoding, pulses- and direction-input counting, or as a pulse input up/down counter.

Applications

- Coordinate measuring machines
- X-Y table
- Machine control

Specifications

- Encoder type: Single-ended or differential
- Logic levels: TTL- and CMOS-compatible
- Power consumption: +5V@500mA

Features

- Accepts inputs from incremental or quadrature encoders
- 3 independent axes
- Max. quadrature input frequency: 1MHz
- Counts per encoder cycle: x1, x2, x4 (software selectable)

Encoder input modes:

- Quadrature
- Up/Down
- Pulse/Direction

Environmental:

- Operation Temperature: 0 to 60°C
- Storage Temperature: -20°C to 70°C
- Humidity: 0 to 90% non-condensing
- Dimension: 159mm x 108mm

Software

- Encoder-300 Development Toolkit for DOS
- Encoder-300 Development Toolkit for Win95
- Encoder-300 Development Toolkit for WinNT

Order Description

- Encoder 300: 3 Axes Encoder interface board

Options

- Encoder-300 LabVIEW Development Toolkit for Win95
- Encoder-300 LabVIEW Development Toolkit for WinNT

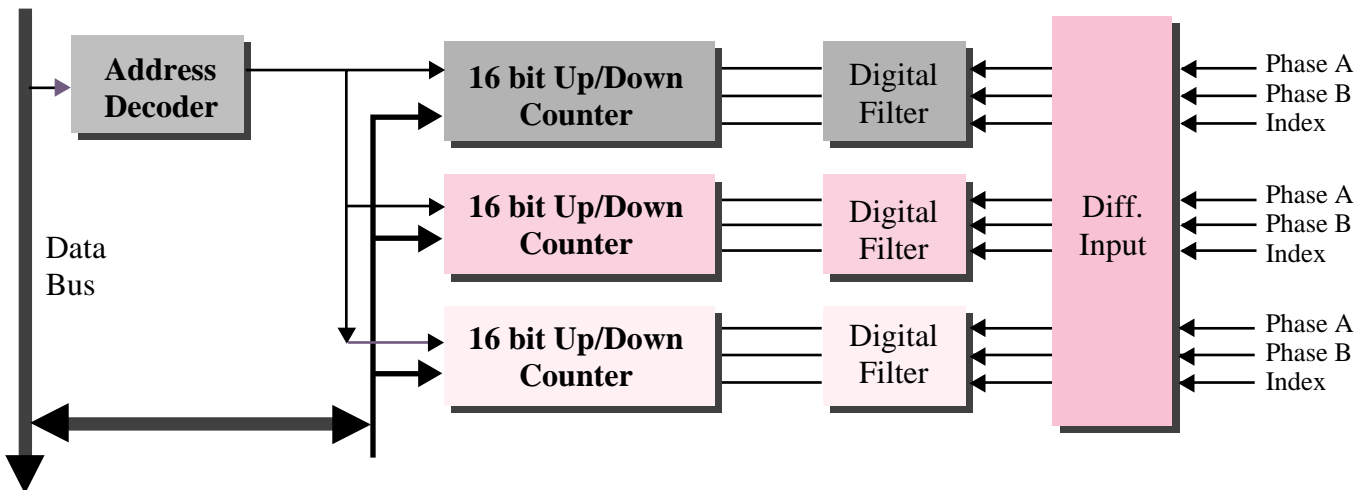

Motion Board