









Ethernet Switches

7

7.1 Overview		P7-1-1
	• Managed Switch for Industrial Ethernet Application	P7-1-2
	• Unmanaged Ethernet Switch	P7-1-3
	• Media Converter	P7-1-3
	• IP67 Waterproof Switch	P7-1-3
	• Real-time Redundant Ring Switch	P7-1-4
	• Managed Ethernet Switch	P7-1-4
	• Cyber-Ring Ethernet Self-healing Technology	P7-1-5
7.2 Product Showcase		P7-2-1
	• Unmanaged Ethernet Switches	P7-2-1
	• Managed Ethernet Switches	P7-2-3
	• Media Converters	P7-2-4

7.1. Overview

Ethernet is an ideal medium to transport large volumes of data, at speed, across great distances. Previously, multiple networks carrying specific protocols were installed side by side to carry out unique tasks. This inevitably led to project costs increasing as additional fiber optic or copper cables were installed to deal with the increasing volume of data. Using Ethernet, a single fiber optic cable can carry multiple protocols. Furthermore, manufacturers are exporting their legacy protocols onto Ethernet, designing new IP based communication protocols and providing embedded Web-Pages within devices that offer real-time information using simple tools like Internet Explorer and Netscape Navigator.

Early Ethernet were based on a hub or repeater. These units have no intelligence and therefore are unable to identify any information contained within the Header frame of an Ethernet packet. This means that it is not capable of determining which port to send the frame to. Therefore, every frame is sent to every port.

A switch, like a hub, has to forward and receive packets from one network or device to another. The switch could forward all packets, but if this was the case it would have similar behaviour to a hub. It would be more intelligent if the switch only forwarded packets which needed to travel from one network or device to another.

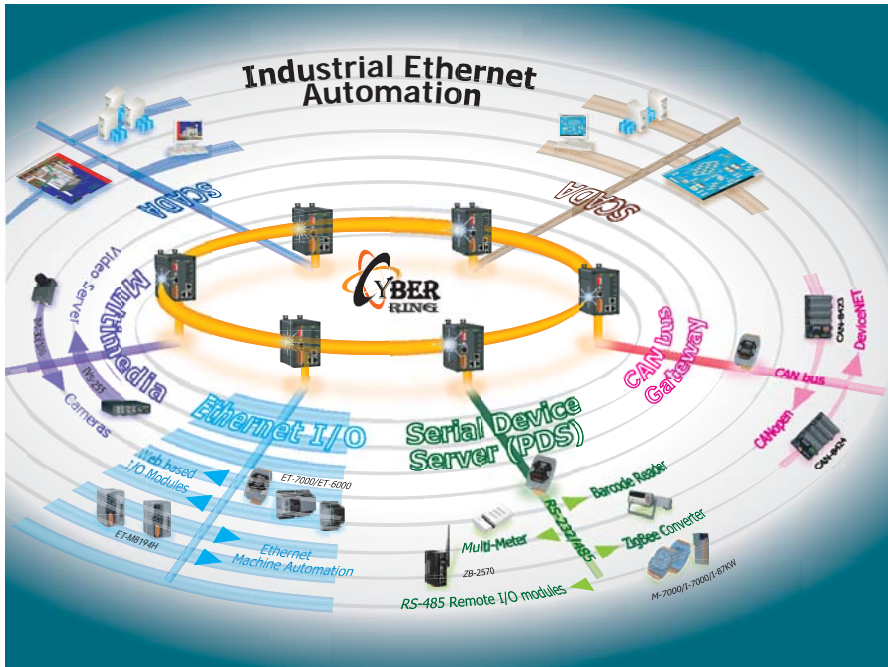

There are many poorly designed switches existing in the market, and most of them are fragile, easy to collapse, and always suffer from transmission delay and unreliable communication conditions due to packet collisions or other issues. Users who have had experiences with those poor switches should try our high quality ones. ICP DAS's switches only choose "REAL INDUSTRIAL" grade switch chips that are temperature tolerant and highly reliable. They are all well-designed by skilled engineers and passed very strict communication and environment tests. All our switches can serve for a long life and guarantee to function perfectly under harsh environments.

Managed Switch for Industrial Ethernet Application

The managed switch can be configured through RS-232 port via serial console or Ethernet port using telnet or Web browser. In addition, the switch supports a lot of powerful managed functions, such as 802.1Q Tag-based VLAN, Port-based VLAN, 802.1p QoS (Quality of Service), Port Trunking, Spanning Tree, Cable Testing and Port Mirroring.

Built-in ICP DAS Cyber-Ring technique enables multiple switches to be placed into a redundant ring. The switch detects and recovers from a fiber or copper link failure within approximately 50 ms – for the majority of applications a seamless process. Modbus/TCP, Modbus/RTU and OPC supported, SCADA application can monitor status of Ethernet and fiber port with Modbus or OPC protocol.

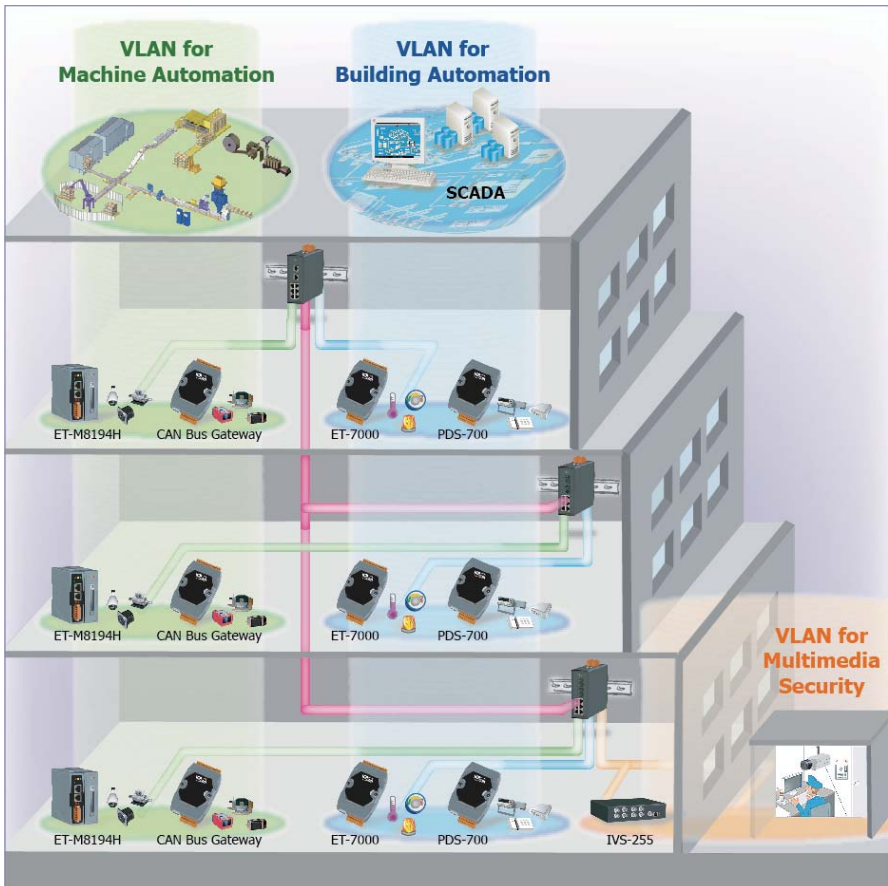

Unmanaged Ethernet Switch

Industrial rated switches are intended to be installed in both harsh climatic environments and noisy electrical installations. Such switches are an excellent example of true industrial design principles

- Very high operating temperatures (down to -40 °C and up to 75 °C)
- DIN-Rail
- Wide DC operating voltages



Media Converter

The utilization of fiber optic data transmission for industrial automation and process control has become increasingly popular over the past decade. A basic fiber optic system, using an optical transceiver circuit and fiber optic media, offers a wide array of benefits that are not available with traditional copper conductors.

IP67 Waterproof Switch

IP67 Ethernet Switches are designed for use in industrial waterproof/harsh environments. The rugged packaging and IP67 connectors guarantee a total protection that can withstand a variety of extreme conditions such as high temperatures, extreme shocks & vibrations, dust particles or even liquid immersion. They can be directly mounted to any machine or convenient flat surface.



Real-time Redundant Ring Switch

The Real-time Redundant Ring Switch offers fault-tolerant industrial Ethernet with ring network topology. The built-in ICP DAS proprietary Cyber-Ring technology detects and recovers from a fiber or copper link failure within approximately 50 ms – for the majority of applications a seamless process. Modbus/TCP, Modbus/RTU and OPC supported, SCADA application can monitor status of Ethernet and fiber port with Modbus or OPC protocol. And, the relay output facility can deliver warning signal while dual power or network link fails.

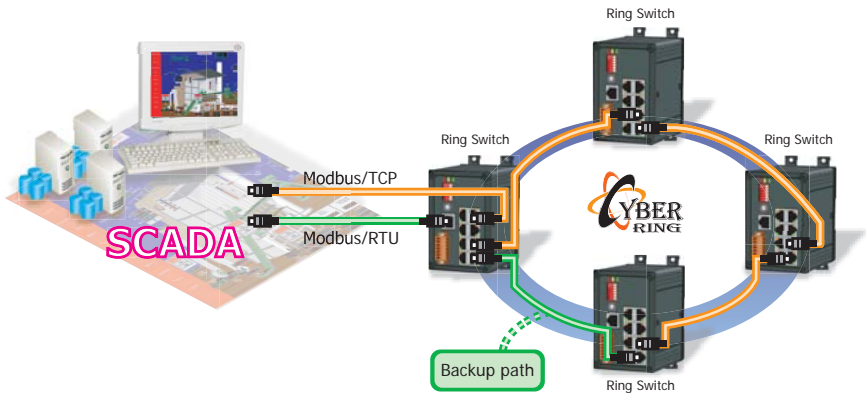

Managed Ethernet Switch

The ICP DAS Managed Switch provides a cost-effective managed Ethernet solution for industrial control and automation. It provides lots of powerful managed functions, such as 802.1Q Tag-based VLAN, Port-based VLAN, 802.1p QoS (Quality of Service), Port Trunking, Spanning Tree, Cable Testing and Port Mirroring. These managed functions can be configured through RS-232 port via serial console or Ethernet port using telnet or Web browser. In addition, the built-in Cyber-Ring technology offers real-time fault-tolerant ring topology to increase the reliability and performance of network. It is an ideal Managed Switch for industrial environments.



7 Cyber-Ring Ethernet Self-healing Technology

It is undoubted that the power of an Ethernet LAN (Local Area Network) is tremendous when applied to factory floor or industrial automation applications. However, you cannot just use commercial Ethernet switch there. Harsh environment will become a challenge to your switch, and, in many case, fault-tolerant network is also a must. To satisfy these, ICP DAS's Cyber-Ring technology provides you a rugged fault-tolerant, plug and play Ethernet solution.

The ICP DAS's proprietary Cyber-Ring self-healing Ethernet technology can establish industrial Ethernet with high reliability and fault-tolerant capability. It can employ a ring topology network over either copper or fiber optic cable. While standard STP typically requires 20s to 30s for network structure reconfiguration following a link failure, Cyber-Ring technology reduces this downtime to within half a second. Average experience indicates a typical fault recovery time is 300 ms for Cyber-Ring fault-tolerant network.

Features

- High reliability and fault-tolerant
- Real-time deterministic performance
- Scalable and flexible ring topology
- Cost-effective industrial redundant Ethernet solution
- Plug and play

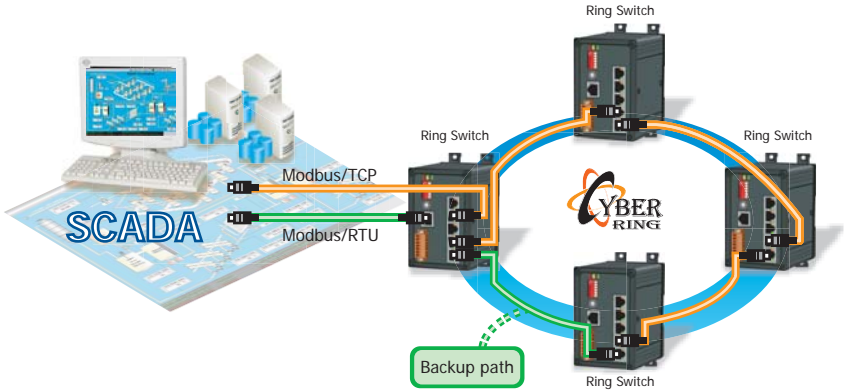

Recovery Time

The recovery time of Cyber-Ring network consists of two parts, fault detected time and reconfiguration time. Recovery time of Cyber-Ring network is associated with the number of switches of the network and Cyber-Ring technology offers a variable preconfigured recovery time to support a wide range of number of switches. Typically, the recovery time of Cyber-Ring network with ten switches is less than 300 ms.

Fault Detected Time

Fault detected time is defined as the time from the occurrence of the fault until fault detected. There is a master switch of Cyber-Ring network checks the health condition of Cyber-Ring network periodically. If active path is not response after a preconfigured period of time, the master assumes that active path is failed and invokes reconfiguration mechanism to redirect traffics to the backup path.

Reconfiguration Time

The reconfiguration time of Cyber-Ring network is less than 5 ms per switch. For example, a Cyber-Ring fault-tolerant network that is comprised of ten switches, the expected worst case reconfiguration time will be 50 ms. When a fault is detected, the Cyber-Ring network will reconfigure to provide alternative traffic path of the ring within 50 ms.

7.2. Product Showcase



Unmanaged Ethernet Switches

5-port 10/100 Base-TX

The NS-205 series has 5 Ethernet Switching ports that support 10/100 Base-TX, with a 10/100M auto negotiation feature and auto MDI/MDI-X function.

NS-205 CR Series



- Automatic MDI/MDI-X crossover for plug-and-play
- Each port supports both 10/100 Mbps speed auto negotiation
- Store-and-forward architecture
- Full duplex IEEE 802.3x and half duplex backpressure flow control
- Integrated look-up engine with dedicated 1024 unicast MAC addresses
- Store-and-forward architecture
- Supports +10 V_{DC} ~ +30 V_{DC} Reverse Polarity Protection
- Operating temperature range: -40 °C ~ +75 °C
- DIN-Rail

4-port PoE and 1 RJ-45 Uplink

The NS-205PSE is a 5-port unmanaged PoE (Power over Ethernet) Industrial Ethernet Switch, it supports 4-PoE Port which are classified as power source equipments (PSE).

NEW NS-205PSE CR



- Automatic MDI/MDI-X crossover for plug-and-play
- Each port supports both 10/100 Mbps speed auto negotiation
- Store-and-forward architecture
- Full duplex IEEE 802.3x and half duplex backpressure flow control
- 3.2 Gbps high performance memory bandwidth
- Power Inputs +46 V_{DC} ~ +55 V_{DC}
- Operating temperature range: -40 °C ~ +75 °C
- DIN-Rail
- IEEE 802.3af compliant PoE ports
- 4-PoE Port with power sourcing equipment (PSE) operation
- Auto-detection of PD (powered devices) and automatic power management over-temperature, over-current and over-voltage detection

8-port 10/100/100 Base-T

The NS-208G/NSM-208G series has 8 Ethernet Switching ports that support 10/100/1000 Base-T, with a 10/100/1000M auto negotiation feature and auto MDI/MDI-X function. It can connect 8 workstations and automatically switches the transmission speed (10 Mbps or 100 Mbps or 1000 Mbps) for corresponding connections.

NEW NS(M)-208G CR NS(M)-208AG CR Series



- Automatic MDI/MDI-X crossover for plug-and-play
- Each port supports both 10/100 and 1000 Mbps speed auto negotiation
- Store-and-forward architecture
- Full duplex IEEE 802.3x and half duplex backpressure flow control
- 16 Gbps high performance memory bandwidth
- Supports +10 V_{DC} ~ +30 V_{DC} for NS-208G and NSM-208G
- Supports +10 V_{DC} ~ +30 V_{DC} for NS-208AG and NSM-208AG
- Operating temperature range: -40 °C ~ +75 °C
- DIN-Rail

5-port 10/100/1000 Base-T

The NS-205G is 5-port unmanaged gigabit switch that support 10/100/1000 Base-T, with a 10/100/1000M auto negotiation feature and auto MDI/MDI-X function. It can connect 5 workstations and automatically switch the transmission speed (10 Mbps or 100 Mbps or 1000 Mbps) for corresponding connections.

NEW NS-205G CR



- Power saving Technology
- Automatic MDI/MDI-X crossover for plug-and-play
- Each port supports 10/100 and 1000 Mbps speed auto negotiation
- Store-and-forward architecture
- 10 Gbps high performance memory bandwidth
- Full duplex IEEE 802.3x and half duplex backpressure flow control
- Power Inputs +10 V_{DC} ~ +30 V_{DC}
- Operating temperature range: -40 °C ~ +75 °C
- DIN-Rail

8-port 10/100 Base-TX

The NS-208/NSM-108 series has 8 Ethernet Switching ports that support 10/100 Base-TX, with a 10/100M auto negotiation feature and auto MDI/MDI-X function.

NS-208 CR NSM-108 CR Series



- Automatic MDI/MDI-X crossover for plug-and-play
- Each port supports both 10/100 Mbps speed auto negotiation
- Store-and-forward architecture
- Full duplex IEEE 802.3x and half duplex backpressure flow control
- 2 Gbps high performance memory bandwidth
- Power Inputs +10 V_{DC} ~ +30 V_{DC}
- Operating temperature range: -40 °C ~ +75 °C
- DIN-Rail

4-port 10/100 Base-TX and 100 Base-FX Fiber

The NS-205F/NSM-205F series is a Unmanaged 4-port Industrial Ethernet (10/100 Base-TX) to Fiber Port (100 Base-FX) switch that secures data transmission by using fiber optic transmission to provide immunity from EMI/RFI interference.

NS(M)-205F CR Series



- Automatic MDI/MDI-X crossover for plug-and-play
- Each port supports both 10/100 Mbps speed auto negotiation
- Store-and-forward architecture
- Full duplex IEEE 802.3x and half duplex backpressure flow control
- 3.2 Gbps high performance memory bandwidth
- Frame buffer memory: 512 Kbit
- Integrated look-up engine with dedicated 1024 unicast MAC addresses
- Supports +10 V_{DC} ~ +30 V_{DC}
- Operating temperature range: 0 °C ~ +70 °C

4-port 10/100 Base-TX and Dual 100 Base-FX Fiber

The NS-206F/NSM-206F series is a Unmanaged 4-port Industrial 10/100 Base-TX and Dual 100 Base-FX Switch that secures data transmission by using fiber optic transmission to provide immunity from EMI/RFI interference.

NS(M)-206F CR Series

- Automatic MDI/MDI-X crossover for plug-and-play
- Each port supports both 10/100 Mbps speed auto negotiation
- Store-and-forward architecture
- Full duplex IEEE 802.3x and half duplex backpressure flow control
- 1.6 Gbps high performance memory bandwidth
- Frame buffer memory: 256 Kbit
- Integrated look-up engine with dedicated 1024 unicast MAC addresses
- Supports +10 V_{DC} ~ +30 V_{DC}
- Operating temperature range: 0 °C ~ +70 °C
- Din-Rail

8-port 10/100 Base-TX and 100 Base-FX Fiber

The NS-209F/NSM-209F series is a Unmanaged 8-port Industrial 10/100 Base-TX and one 100 Base-FX Switch that secures data transmission by using fiber optic transmission to provide immunity from EMI/RFI interference.

NEW
NS-209F CR Series
Available soon
NSM-209F CR Series

- Automatic MDI/MDI-X crossover for plug-and-play
- Each port supports both 10/100 Mbps speed auto negotiation
- Store-and-forward architecture
- Full duplex IEEE 802.3x and half duplex backpressure flow control
- 2 Gbps high performance memory bandwidth
- Integrated look-up engine with dedicated 2048 unicast MAC addresses
- Supports +12 V_{DC} ~ +48 V_{DC}
- Operating temperature range: 0 °C ~ +70 °C
- DIN-Rail

5-port 10/100 Base-TX with IP67 Casing

NS-205-IP67 Ethernet switch are designed for use in industrial waterproof/harsh environments.

NEW
NS-205-IP67 CR Series

- Automatic MDI/MDI-X crossover for plug-and-play
- Each port supports both 10/100 Mbps speed auto negotiation
- Store-and-forward architecture
- Full duplex IEEE 802.3x and half duplex backpressure flow control
- 1.4 Gbps high performance memory bandwidth
- Integrated look-up engine with dedicated 1024 unicast MAC addresses
- Supports +10 VDC ~ +30 VDC with 1 kV Isolation Reverse Polarity Protection
- Plastic casing with IP67
- Operating temperature range: -10 °C ~ +60 °C
- Din-Rail

 Managed Ethernet Switches

5-port Real-time Redundant Ring Switch

The RS-405/RSM-405 series is a 5-port Industrial Ethernet (10/100 Base-TX) Real-Time Redundant Ring Switch.

NEW
RS(M)-405 CR Series



- Automatic MDI/MDI-X crossover for plug-and-play
- Each port supports both 10/100 Mbps speed auto negotiation
- Store-and-forward architecture
- Full duplex IEEE 802.3x and half duplex backpressure flow control
- 3.2 Gbps high performance memory bandwidth
- Frame buffer memory: 1 Mbit
- Integrated look-up engine with dedicated 2048 unicast MAC addresses
- Redundant Power Inputs +10 V_{DC} ~ +30 V_{DC}
Power failure alarm by relay output
- Operating temperature range: -40 °C ~ +75 °C
- DIN-Rail

5-port Real-time Redundant Ring Switch with 2-Fiber Port

The RS-405F/RSM-405F series is a 5-port Industrial Ethernet Real-Time Redundant Ring Switch with 2-Fiber Port that secures data transmission by using fiber optic transmission to provide immunity from EMI/RFI interference.

NEW
RS(M)-405F CR Series



- Automatic MDI/MDI-X crossover for plug-and-play
- Each port supports both 10/100 Mbps speed auto negotiation
- Store-and-forward architecture
- Full duplex IEEE 802.3x and half duplex backpressure flow control
- 3.2 Gbps high performance memory bandwidth
- Frame buffer memory: 512 Kbit
- Integrated look-up engine with dedicated 1024 unicast MAC addresses
- Redundant Power Inputs +10 V_{DC} ~ +30 V_{DC}
Power failure alarm by relay output
- Operating temperature range: 0 °C ~ +70 °C

8-port Real-time Redundant Ring Switch

The RS-408/RSM-408 series is an 8-port Industrial Ethernet (10/100 Base-TX) Real-Time Redundant Ring Switch.

NEW
RS(M)-408 CR Series



- Automatic MDI/MDI-X crossover for plug-and-play
- Each port supports both 10/100 Mbps speed auto negotiation
- Store-and-forward architecture
- Full duplex IEEE 802.3x and half duplex backpressure flow control
- 3.2 Gbps high performance memory bandwidth
- Frame buffer memory: 1 Mbit
- Integrated look-up engine with dedicated 2048 unicast MAC addresses
- Redundant Power Inputs +10 V_{DC} ~ +30 V_{DC}
Power failure alarm by relay output
- Operating temperature range: -40 °C ~ +75 °C
- DIN-Rail

8-port Industrial Ethernet Layer 2 Managed Switch

The MSM-508 is an 8-port Industrial Ethernet (10/100 Base-TX) Layer 2 Managed Switch. MSM-508 supports 10/100M auto negotiation feature and auto MDI/MDI-X function.

NEW
MSM-508 CR



- Automatic MDI/MDI-X crossover for plug-and-play
- Each port supports both 10/100 Mbps speed auto negotiation
- Store-and-forward architecture
- Full duplex IEEE 802.3x and half duplex backpressure flow control
- 3.2 Gbps high performance memory bandwidth
- Frame buffer memory: 1 Mbit
- Integrated look-up engine with dedicated 2048 unicast MAC addresses
- Supports +12 V_{DC} ~ +48 V_{DC}
Power failure alarm by relay output
- Operating temperature range: -40 °C ~ +75 °C
- DIN-Rail mount and Screw hole for wall mounting kit

8-port Industrial Ethernet Layer 2 Managed Switch with 2-Fiber Port

The MSM-508F series is an 8-port Industrial Ethernet Layer 2 Managed Switch with 2-Fiber Port that secures data transmission by using fiber optic transmission to provide immunity from EMI/RFI interference.

NEW
MSM-508F CR Series



- Automatic MDI/MDI-X crossover for plug-and-play
- Each port supports 10/100 and 1000 Mbps speed auto negotiation
- Store-and-forward architecture
- Full duplex IEEE 802.3x and half duplex backpressure flow control
- 3.2 Gbps high performance memory bandwidth
- Frame buffer memory: 1 Mbit
- Integrated look-up engine with dedicated 2048 unicast MAC addresses
- Supports +12 V_{DC} ~ +48 V_{DC}
Power failure alarm by relay output
- Operating temperature range: 0 °C ~ +70 °C
- DIN-Rail mount and Screw hole for wall mounting kit



Media Converters

10/100 Base-TX to 100 Base-FX

The NS-200F series is a Ethernet (10/100 Base-TX) to Media (100 Base-FX) converter. The Ethernet supports 10/100M auto negotiation feature and auto MDI/MDI-X function.

NS-200F CR Series

- Automatic MDI/MDI-X crossover for plug-and-play
- Supports both 10/100 Mbps speed auto negotiation
- Store-and-forward architecture
- Full duplex IEEE 802.3x flow control
- 1.4 Gbps high performance memory bandwidth
- Frame buffer memory: 256 Kbit
- Integrated look-up engine with dedicated 1024 unicast MAC addresses
- Supports +10 V_{DC} ~ +30 V_{DC} Reverse Polarity Protection
- Operating temperature range: 0 °C ~ +70 °C
- DIN-Rail

1000 Base-T to 1000 Base-SX/LX

The NS-200G series provides one RJ-45 auto sensing 10/100/1000 Base-T port and one 1000 Base-SX/LX SFP port. The RJ-45 port is full/half duplex capable.

Available soon
NS-200G CR Series

- Automatic MDI/MDI-X crossover for plug-and-play
- Store-and-forward architecture
- Full duplex IEEE 802.3x
- Supports +12 V_{DC} ~ +48 V_{DC} Reverse Polarity Protection
- Operating temperature range: 0 °C ~ +70 °C
- DIN-Rail

Single-Strand 10/100 Base-TX to 100 Base-FX

Using the fiber optic medium for Ethernet applications has become more popular due to fiber optic's excellent physical features, especially for long distance networks.

NS-200WDM CR Series

- Automatic MDI/MDI-X crossover for plug-and-play
- Supports both 10/100 Mbps speed auto negotiation
- Store-and-forward architecture
- Full duplex IEEE 802.3x and half duplex backpressure flow control
- 1.4 Gbps high performance memory bandwidth
- Integrated look-up engine with dedicated 1024 unicast MAC addresses
- Supports +12 V_{DC} ~ +48 V_{DC} Reverse Polarity Protection
- Operating temperature range: 0 °C ~ +70 °C
- DIN-Rail