

3.3. DS-700 Serial-to Ethernet Device Servers



Introduction

The DS-700 is a series of Serial-to-Ethernet Device Servers that are designed for linking RS-232/422/485 devices to an Ethernet network. By using the VxComm Driver/Utility, the built-in COM port of the DS-700 series can be virtualized to a standard PC COM port in Windows. By virtue of its protocol independence, a small size and flexibility, the DS-700 series meets the demands of virtually any network-enabled application.

The DS-712 is equipped with a male DB-9 connector and supports a 5-wire RS-232 port, while the DS-715 is equipped with a removable terminal block connector and supports a 4-wire RS-422 port or a 2-wire RS-485 port with 2000 V_{rms} isolation.

The DS-700 is a non-programmable device server, while the PPDS-700-MTCP is a programmable product. The PPDS-700-MTCP series features true IEEE 802.3af-compliant (classification, Class 1) Power over Ethernet (PoE) using a standard category 5 Ethernet cable to receive power from a PoE switch like the NS-205PSE. The PPDS-700-MTCP also works as a Modbus/TCP to Modbus/RTU gateway that supports most SCADA/HMI communications based on the Modbus/TCP protocol.

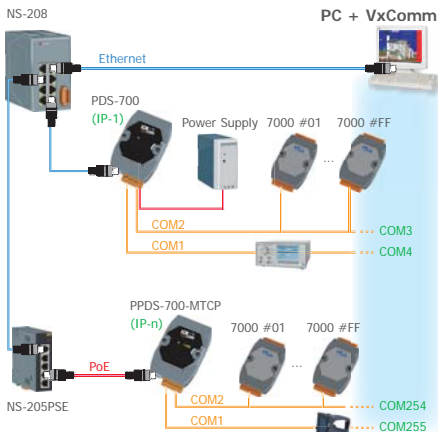

Applications

Factory, Building and Home Automation

RS-232

Features

- Incorporate Serial Devices in an Ethernet network
- "Virtual COM" extends PC COM ports
- Virtual COM for 32-bit and 64-bit Windows XP/2003/Vista/7
- High Performance Device Server
- Watchdog Timer suitable for use in harsh environments
- Power Reverse Polarity Protection
- Serial Port +/-4 kV ESD Protection Circuit
- RoHS Compliant with no Halogen
- Built-in High Performance MiniOS7 from ICP DAS
- 10/100 Base-TX, RJ-45 Port (Auto-negotiating, auto MDI/MDI-X, LED Indicator)
- PPDS-712-MTCP supports Modbus/TCP and Modbus/RTU
- PPDS-712-MTCP supports PoE (IEEE 802.3af, Class 1)
- Low power consumption
- Palm-Size with DIN-Rail Mounting
- Made from fire retardant materials (UL94-V0 Level)
- Male DB-9 Connector



System Specifications

Models	DS-712	PPDS-712-MTCP
CPU		
CPU	80186, 80 MHz or compatible	
SRAM	512 KB	
Flash Memory	Flash ROM: 512 KB	
EEPROM	16 KB; Data retention: 40 years	
Built-in Watchdog Timer	Yes	
Communication Interface		
Non-isolated	COM1	RS-232 (Tx/D, Rx/D, RTS, CTS, GND)
Ethernet	10/100 Base-TX, RJ-45 port (Auto-negotiating, auto MDI/MDI-X, LED Indicator)	
PoE	-	IEEE 802.3af
COM Port Formats		
Data Bit	7, 8: for COM1	
Parity	None, Even, Odd, Mark, Space	
Stop Bit	1: for COM1	
Baud Rate	115200 bps max.	
LED Indicators		
L1	Run (Red)	
L2	Link/Act (Red)	
L3	10/100M (Orange)	
PoE	-	Green
Power		
Protection	Power Reverse Polarity Protection	
Required Supply Voltage	+12 Vdc ~ +48 Vdc (non-regulated)	PoE or +12 Vdc ~ +48 Vdc (non-regulated)
Power Consumption	2.0 W	2.2 W
Mechanical		
Flammability	Fire Retardant Materials (UL94-V0 Level)	
Dimensions	72 mm x 118 mm x 35 mm (W x H x D)	
Installation	DIN-Rail or Wall mounting	
Environment		
Operating Temperature	-25 °C ~ +75 °C	
Storage Temperature	-40 °C ~ +80 °C	
Humidity	5 ~ 90% RH, non-condensing	

Pin Assignments

Terminal No.	Pin Assignment
E1	
01	N/A
02	N/A
03	N/A
04	N/A
05	INIT*
06	N/A
07	N/A
08	(R) +Vs
09	(B)GND

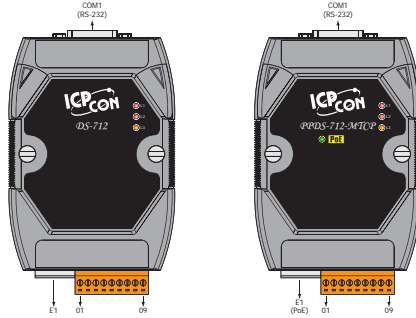

Pin Assignment	Terminal No.	Pin Assignment
GND	05	09 --
--	04	08 CTS
TxD	03	07 RTS
RxD	02	06 --
--	01	

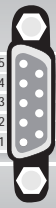

COM1: Male DB-9 Connector

Wiring

3-wire RS-232 Wiring

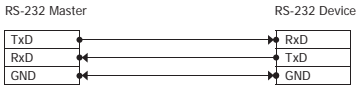

Dimensions (Unit: mm)

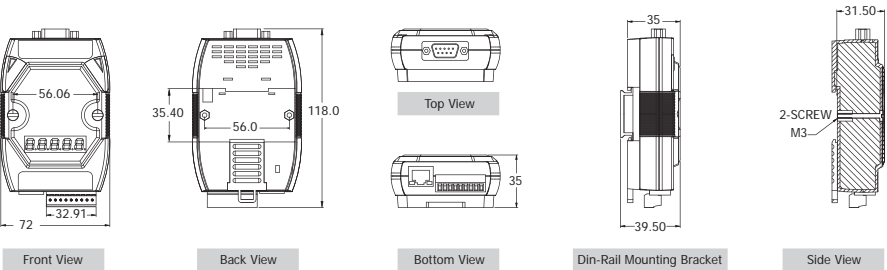

Ordering Information

DS-712 CR	Device Server with 1 RS-232 port (RoHS)
PPDS-712-MTCP CR	Programmable Device Server with PoE, Modbus/TCP and 1 RS-232 port (RoHS)

Accessories

GPSU06U-6	24 V _{DC} /0.25 A, 6 W Power Supply
MDR-20-24	24 V _{DC} /1 A, 24 W Power Supply with DIN-Rail Mounting
DIN-KA52F-48	48 V _{DC} /0.52 A, 25 W Power Supply with DIN-Rail Mounting
CA-0915	9-Pin Male-Female D-Sub Cable, 1.5 m Cable
NS-205 CR	Unmanaged 5-port Industrial Ethernet Switch (RoHS)
NS-205PSE CR	Unmanaged Ethernet Switch with 4 PoE Ports and 1 RJ-45 Uplink (RoHS)
DN-09-2F	I/O Connector Block with DIN-Rail Mounting and Two 9-Pin Male Header Includes CA-0910F x 2 (9-Pin Female-Female D-Sub Cable 1.0 m)



Introduction

The DS-700 is a series of Serial-to-Ethernet Device Servers that are designed for linking RS-232/422/485 devices to an Ethernet network. By using the VxComm Driver/Utility, the built-in COM port of the DS-700 series can be virtualized to a standard PC COM port in Windows. By virtue of its protocol independence, a small size and flexibility, the DS-700 series meets the demands of virtually any network-enabled application.

The DS-712 is equipped with a male DB-9 connector and supports a 5-wire RS-232 port, while the DS-715 is equipped with a removable terminal block connector and supports a 4-wire RS-422 port or a 2-wire RS-485 port with 2000 V_{rms} isolation.

The DS-700 is a non-programmable device server, while the PPDS-700-MTCP is a programmable product. The PPDS-700-MTCP series features true IEEE 802.3af-compliant (classification, Class 1) Power over Ethernet (PoE) using a standard category 5 Ethernet cable to receive power from a PoE switch like the NS-205PSE. The PPDS-700-MTCP also works as a Modbus/TCP to Modbus/RTU gateway that supports most SCADA/HMI communications based on the Modbus/TCP protocol.

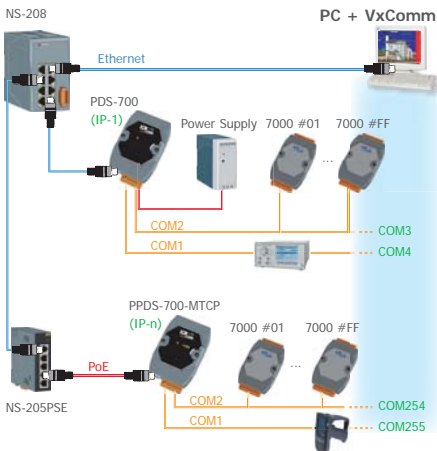

Applications

Factory, Building and Home Automation

RS-422/485

Features

- Incorporate Serial Devices in an Ethernet network
- "Virtual COM" extends PC COM ports
- Virtual COM for 32-bit and 64-bit Windows XP/2003/Vista/7
- High Performance Device Server
- Watchdog Timer suitable for use in harsh environments
- Power Reverse Polarity Protection
- Serial Port +/- 4 kV ESD Protection Circuit
- Self-Tuner ASIC Controller on the RS-485 Port
- RoHS Compliant with no Halogen
- Built-in High Performance MinIOS7 from ICP DAS
- 10/100 Base-TX, RJ-45 Port (Auto-negotiating, auto MDI/MDI-X, LED indicator)
- PPDS-715-MTCP supports Modbus/TCP and Modbus/RTU
- PPDS-715-MTCP supports PoE (IEEE 802.3af, Class 1)
- Low power consumption
- Palm-Size with DIN-Rail Mounting
- Made from fire retardant materials (UL94-V0 Level)



System Specifications

Models	DS-715	PPDS-715-MTCP
CPU		
CPU	80186, 80 MHz or compatible	
SRAM	512 KB	
Flash Memory	Flash ROM: 512 KB	
EEPROM	16 KB; Data retention: 40 years	
Built-in Watchdog Timer	Yes	
Communication Interface		
Isolated (2000 V_{rms})	COM1	RS-422 (TxD+, TxD-, RxD+, RxD-) RS-485 (D2+, D2-)
Ethernet	10/100 Base-TX, RJ-45 port (Auto-negotiating, auto MDI/MDI-X, LED indicator)	
PoE	-	IEEE 802.3af
COM Port Formats		
Data Bit	7, 8; for COM1	
Parity	None, Even, Odd, Mark, Space	
Stop Bit	1; for COM1	
Baud Rate	115200 bps max.	
LED Indicators		
L1	Run (Red)	
L2	Link/Act (Red)	
L3	10/100M (Orange)	
PoE	-	Green
Power		
Protection	Power Reverse Polarity Protection	
Required Supply Voltage	+12 V_{dc} ~ +48 V_{dc} (non-regulated)	PoE or +12 V_{dc} ~ +48 V_{dc} (non-regulated)
Power Consumption	2.0 W	2.2 W
Mechanical		
Flammability	Fire Retardant Materials (UL94-V0 Level)	
Dimensions	72 mm x 124 mm x 35 mm (W x H x D)	
Installation	DIN-Rail or Wall mounting	
Environment		
Operating Temperature	-25 °C ~ +75 °C	
Storage Temperature	-40 °C ~ +80 °C	
Humidity	5 ~ 90% RH, non-condensing	

Pin Assignments

Terminal No.	Pin Assignment
E1	
01	N/A
02	N/A
03	N/A
04	N/A
05	INIT*
06	N/A
07	N/A
08	(R) +Vs
09	(B)GND

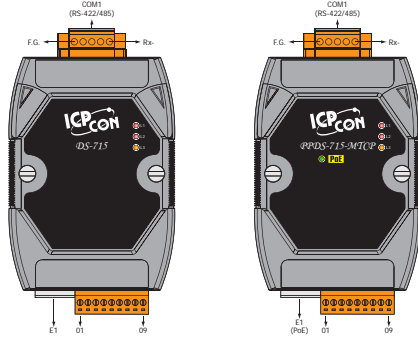

COM1 (RS-422/485)
F.G.
Tx+/D+
Tx-/D-
Rx+
Rx-

Wiring

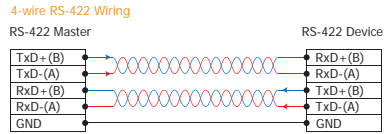
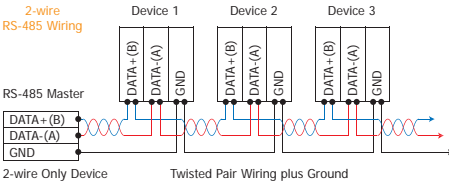

Dimensions (Unit: mm)

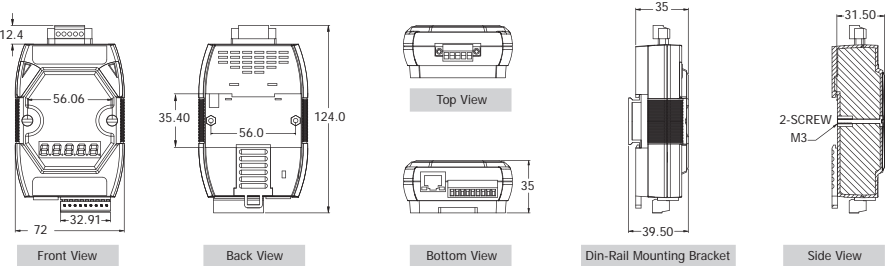

Ordering Information

DS-715 CR	Device Server with 1 Isolated RS-422/RS-485 port (RoHS)
PPDS-715-MTCP CR	Programmable Device Server with PoE, Modbus/TCP and 1 Isolated RS-422/485 port (RoHS)

Accessories

GPSU06U-6	24 Vdc/0.25 A, 6 W Power Supply
MDR-20-24	24 Vdc/1 A, 24 W Power Supply with DIN-Rail Mounting
DIN-KA52F-48	48 Vdc/0.52 A, 25 W Power Supply with Din-Rail Mounting
NS-205 CR	Unmanaged 5-port Industrial Ethernet Switch (RoHS)
NS-205PSE CR	Unmanaged Ethernet Switch with 4 PoE Ports and 1 RJ-45 Uplink (RoHS)